

Inductive Sensors

BASICS AND INSTALLATION



Technisches Glossar

Geben Sie ein Begriff ein.

A B C D E F G H I J K L M N O P Q R S T U V W X Y Z

Begriff

Absolut

Definition

Charakteristik eines magnetorientierten Messsystems, bei dem der Messwert der aktuellen Position sofort nach dem Einschalten verfügbar ist. Jeder Position, z. B. einer Messstrecke, ist ein absolut codiertes digitales Signal oder ein Analogwert zugeordnet. Eine Referenzpunktfahrt ist nicht notwendig.

Abstandssensor mit Analogausgang

Sensor, der ein kontinuierlich variierendes Ausgangssignal erzeugt, das vom Abstand zwischen aktiver Fläche und dem Bedämpfungselement abhängt.

Absolutdruck

Druck gegenüber Druck Null (Vakuum). Der Wertebereich des Absolutdrucks ist immer positiv.

AIDA

Automatisierungsinitiative Deutscher Automobilisten

Aktive Fläche

Aktiv messender Bereich und somit nach außen empfindliche Elektrode/Platte des Elektrodenystems. Sie ist in der Regel etwas kleiner als die Fläche der Abdeckhaube.

> nähere Informationen

Alarmausgang

Vorrichtung/Funktion am Empfänger, die bei Funktionsstörungen ein Warnsignal auslöst. Diese können durch Verschmutzung oder mechanische Dejustierung verursacht sein. Der Alarmausgang ist aktiviert, wenn das Empfangssignal für eine definierte Zeit im Alarmbereich liegt.

INDUCTIVE SENSORS

Principle

Inductive sensors are based on the interaction of metallic targets with the electromagnetic alternating field of the sensor. Eddy currents are induced in the metallic damping material, which removes energy from the field and reduces the height of the oscillation amplitude. This change is processed in the inductive sensor.

The functional groups of Balluff sensors are:

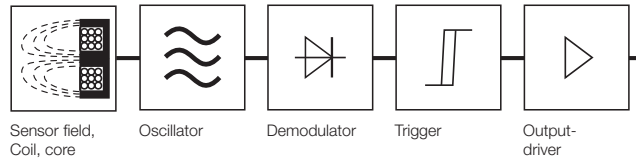

Sensing surface

Actively measuring area and thereby the externally sensitive electrode/plate of the electrode system. It is generally somewhat smaller than the surface of the cover.

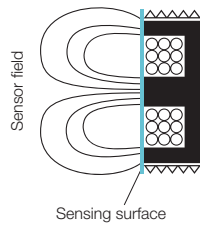

Standard target

A square plate made of Fe 360 (ISO 630), used to define sensing distances per EN 60947-5-2. Thickness is 1 mm; the side length "a" corresponds to the diameter of the inscribed circle of the active surface or $3 s_n$, if the value is larger than the named diameter.

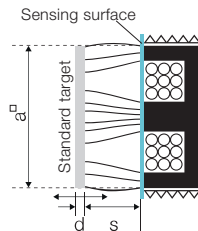

Switching frequency

The maximum speed at which the sensor can reliably detect an object under standardized conditions. This corresponds to the maximum number of switching operations (ON/OFF) per second. The value is dependent on the size and speed of the object and its distance from the sensing face.

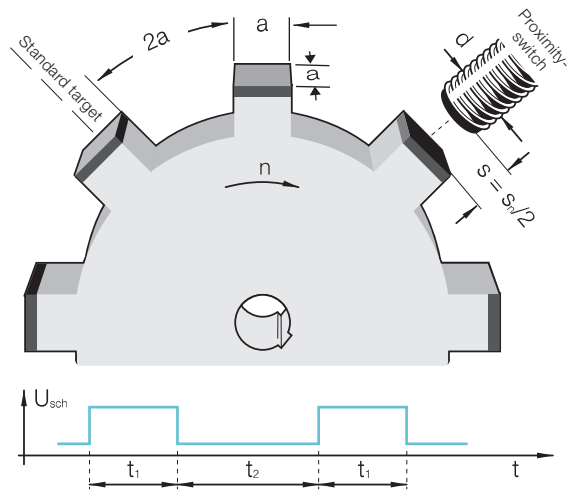

Correction factor

Reduction in the switching distance for damping materials that are not Fe 360.

Material	Factor
Steel	1.0
Copper	0.25...0.45
Brass	0.35...0.50
Aluminum	0.30...0.45
Stainless steel	0.60...1.00
Nickel	0.65...0.75
Cast iron	0.93...1.05

Factor 1 sensors

Identical switching distance for metals such as steel, stainless steel, aluminum or brass.

Steelface sensors

Effective switching distance = rated switching distance × correction factor

Model	Steel FE 360	Stainless steel	Aluminum	Copper	Brass
M8 Ferrous	1	0.1... 0.7	0	0	0.1
M12 Ferrous	1	0.1... 0.7	0	0	0
M12 Non-Ferrous	0	0	1	1.1	0.9
M18 Ferrous	1	0.1... 0.7	0	0	0
M18 Non-Ferrous	0	0	1	1.1	0.9
M30 Ferrous	1	0.1... 0.7	0	0	0
M30 Non-Ferrous	0	0	1	1.1	0.9

Ferrous

Detection of ferromagnetic steel and iron.

Non-Ferrous

Detection of non-magnetizing metals such as aluminum, copper, brass and many stainless steels.

Delay times

Time delay before availability

Duration between the application of power and the availability of a sensor.

Temperature effects and limits

Ambient temperature T_a

The maximum permissible temperature range at which a sensor may be operated while ensuring reliable functioning of the sensor.

Temperature drift

The temperature drift is the deviation of the real switching distance within the temperature range of $-25\text{ °C} \leq T_a \leq +70\text{ °C}$. In accordance with EN 60947-5-2: $\Delta s_r/s_r \leq 10\%$

Magnetic field immunity

Operating principle

Error-free function depends on the magnitude of the welding current and the distance between the sensor and the current-carrying line.

Construction and circuitry design measures ensure that magnetic field immune sensors are not influenced by magnetic fields.

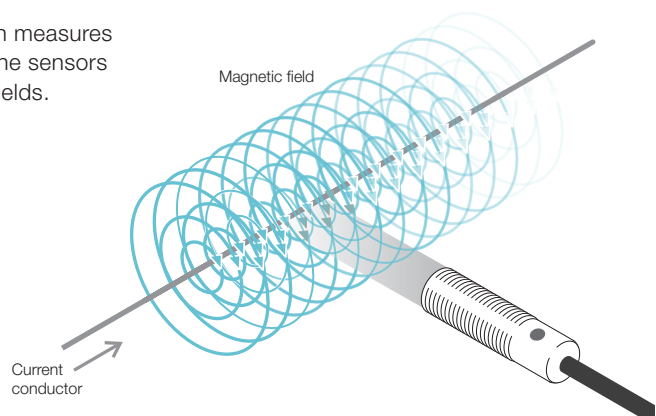

4 | Sensors

Operating voltage U_B

Voltage range (V) in which flawless functioning of the sensor is assured. It includes all voltage tolerances and ripple.

Rated operating voltage

The maximum voltage at which the sensor can be used in normal use. Indicated by U_e . DC switches: $U_e = 24$ V DC; AC and AC/DC switches: $U_e = 110$ V AC.

Voltage drop U_d

The maximum voltage loss of the switching final stage between switching output and $+U_B$ (PNP) or $-U_B$ (NPN) at the maximum specified load current.

Rated isolation voltage

The voltage to which the insulation checks and the air and creepage distances refer. For sensors, the highest rated operating voltage is considered the rated insulation voltage.

Rated supply frequency

Frequency of the operating voltage when using alternating current

Ripple

The maximum permissible AC voltage (peak-to-peak of U_e which may be superimposed on the operating voltage U_S without affecting the function of the sensor.

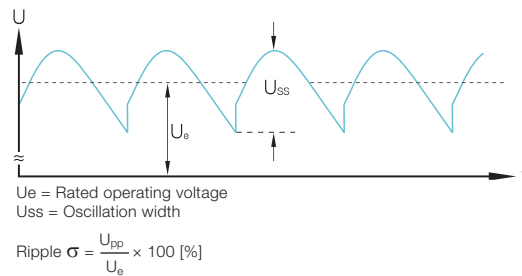

Rated operating current

The permissible output current which flows through the load R_L .

Off-state current

The current which flows in the load circuit when a sensor is not conducting (open).

Short-term current carrying capacity I_k

For an AC device the short-term permissible current I_k (A_{eff}) during a specified turn-on duration t_k (ms) and repetition rate f (Hz).

Limited rated short-circuit current

Value of the unaffected short circuit current which the short circuit protected circuit can withstand during the entire turn-off time (duration of current flow) of the device under specified conditions. This current is prescribed in the standard in order to test the short-circuit protection of sensors.

No-load current The maximum internal current consumption with no load connected to the switching output (in general at $U_{B\ max.}$ and actuated).

Minimum operating current Minimum current (mA) required when energizing the output to maintain operation.

Output resistance Resistance (R_a) at the output of a circuit or component. The output resistance is generally a frequency-dependent, complex resistance with amount and phase and is referred to as output resistance.

Load capacitance The load capacitance is the permitted total capacitance at the sensor output, including cable capacitance.

Output circuits

Driver stages

3-wire DC-switch

PNP, positive switching (current source)

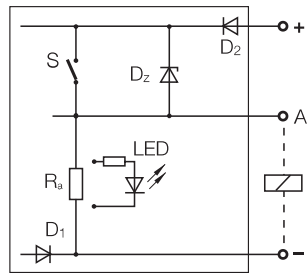

NPN, negative switching (current sink)

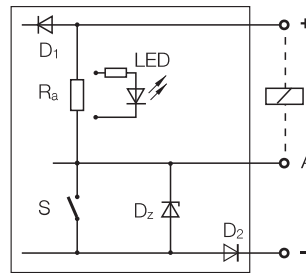

- S = Semiconductor switch
- R_a = output resistance
- LED = Light diode
- D_z = Z-diode, delimiter
- D_1 = Polarity reversal-protected diode
- D_2 = Polarity reversal-protected diode in the load circuit (only with short-circuit protected version)

2-wire DC-switch

Non-polarized

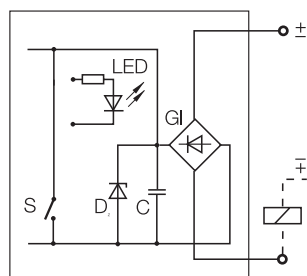

- S = Semiconductor switch
- D_z = Z-diode, delimiter
- C = capacitor
- Gl = bridge rectifier
- LED = light emitting diode

2-wire AC- and AC/DC-switch (all current switch)

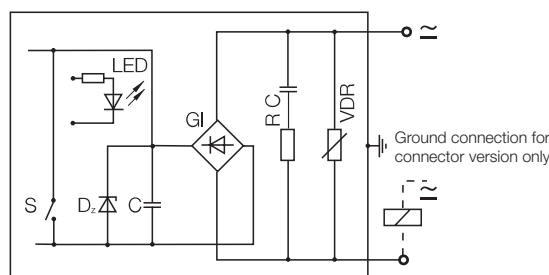

- S = Semiconductor switch
- D_z = Z-diode, delimiter
- C = Sieve condenser
- RC = HF-points-limit
- Gl = bridge rectifier
- LED = Light diode
- VDR = Voltage point limiter

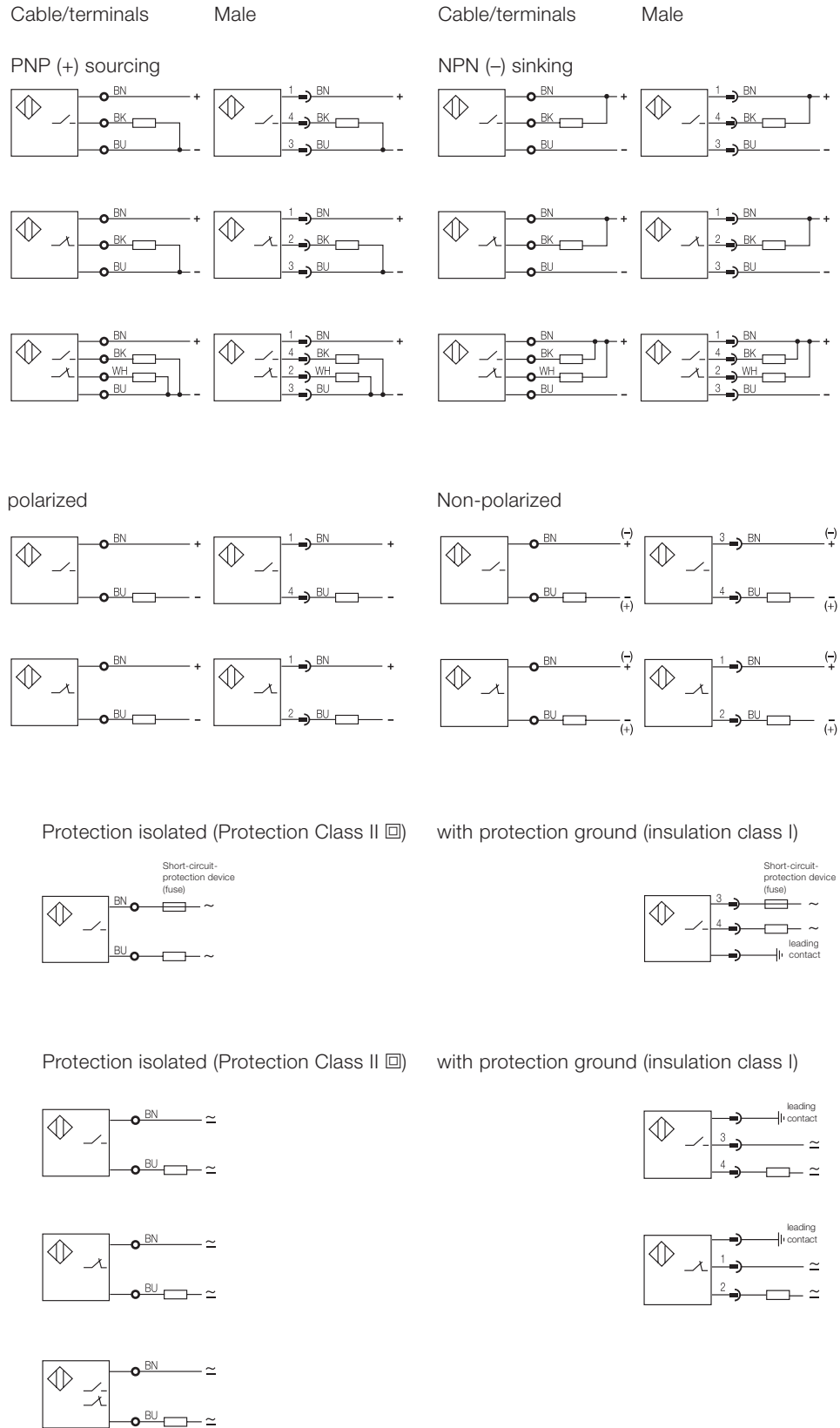

Series connection

Electrical circuit type in which the components are connected to each other in a string so that they form a single current path.

3-wire DC-switch

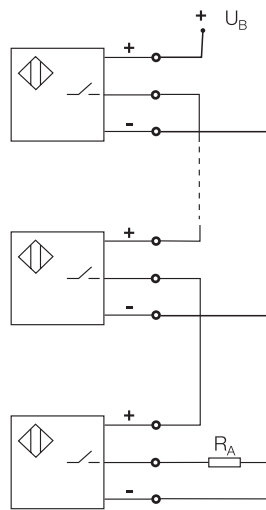

2-wire DC-switch (AC/DC)

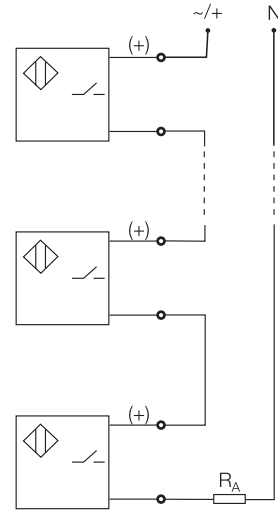

Parallel circuit

Electrical circuit type in which all the switching elements and their same named poles are connected in common to each other, so that multiple current paths result.

3-wire DC-switch

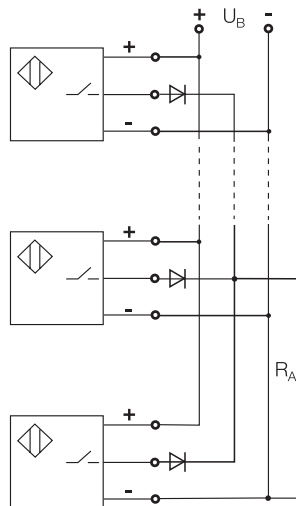

2-wire DC-switch

Parallel wiring of 2-wire-sensors is not recommended, since missed pulses can be caused by the ready delay as the oscillator begins to oscillate.

Utilization categories in accordance with EN 60947-5-2/IEC 60947-5-2

Category		Typical load applications
AC 12	AC-switch	Resistance- and semiconductor loads, optocouplers
AC 140	AC-switch	Small electromagnetic load $I_a \leq 0.2$ A; e.g. contactor relay
DC12	DC-switch	Resistance- and semiconductor loads, optocouplers
DC 13	DC-switch	Electromagnets

Smallest bending radius for standard PUR and standard PVC cables

Bending radius at rest: min. 5 × cable diameter
 Bending radius in motion: min. 10 × cable diameter

Cable break protection Characteristic of 3-wire switches which prevent malfunction when there is a cable break. A built-in diode prevents the current from flowing via the output line A.

Reverse polarity protection Also called polarity reversal protection. This sensor technology protects against reversal of the supply voltage (plus and minus) and reversal of the connection wires (brown and blue).

Short-circuit rating Characteristic of components or assemblies which indicates the short-circuit current which the component or assembly can withstand.

Short-circuit protection (sensors with a maximum voltage of 60 V DC)

The short-circuit protection is achieved in Balluff sensors with clocked or thermal short-circuit protection circuitry. The output stage is thereby protected against overload and short circuit. The release current of the short-circuit protection is above the rated operating current I_e . Currents from switching and load capacitances are specified in the sensor data and do not trigger this function, but rather are masked by a short delay time.

Short-circuit protected/overload protected (sensors for operation optional with AC or DC power supply)

Short-circuit protected/overload protected sensors are often operated with relays or contactors as load. At switch-on, alternating current switching amplifiers (protection contactor/relay) for the sensor are briefly a substantially higher load ($6...10 \times$ rated current) than later in the later static operation, because their core is still open. The static value of the load (current) is only reached after several milliseconds. Not until the magnetic field is closed does the max. permissible rated operating current I_e listed in the data sheet flow through the sensor. The release value for a short-circuit in these sensors therefore has to be significantly greater. If for example the contactor can no longer be entirely closed due to mechanical or electrical reasons, this could lead to an overload of the sensors. This is where the overload protection comes into play. It is designed as slow-acting (time-delayed). Its trigger threshold lies only slightly above the maximum permissible I_e . A reaction (in other words, shutoff) occurs, depending on the height of the overload, only after more than 20 ms. This ensures that properly working relays and contactors can be switched normally, while defective devices will not destroy the Balluff sensors. The short-circuit/overload protection usual has a bistable design and has to be reset after triggering by switching the operating voltage.

Recommended short-circuit protection device for BES033J, BES033H, BES017M

Miniature fuse in accordance with IEC 60127-2 sheet 1, ≤ 2 A (fast-acting). The fuse has to be in the load current line; the fuse may not be placed in the output line.

Approach direction

Direction of an object as it enters the detection range/active range of a sensor.

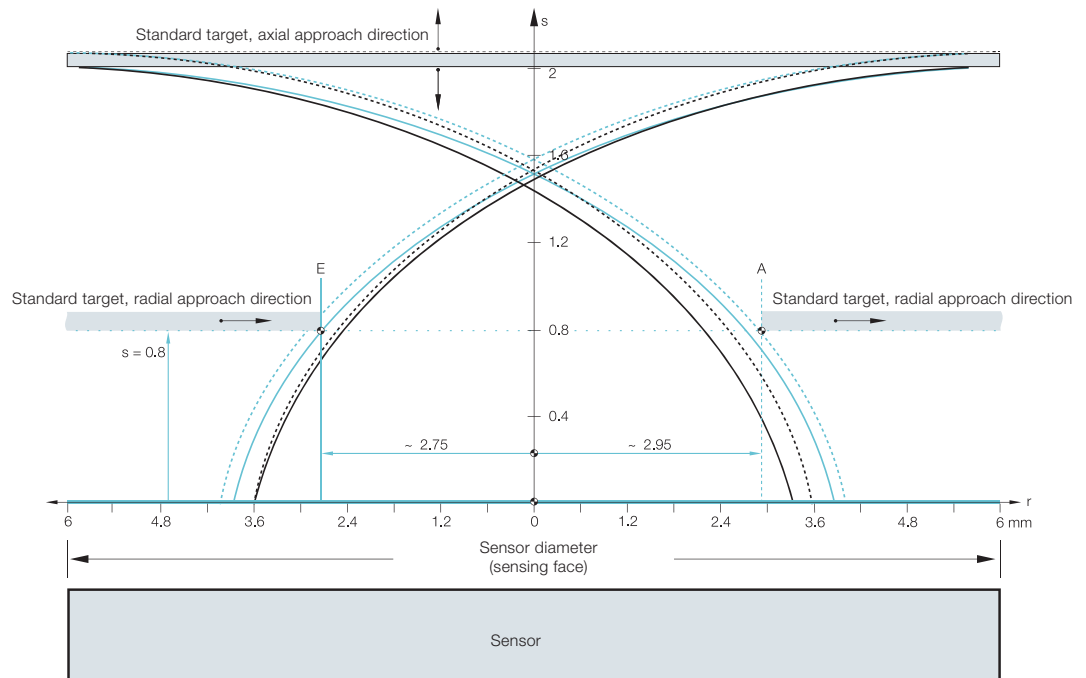

Axial and radial damping

When damping in an axial direction, the standard target is moved concentric to the system axis. The switchpoint is thereby determined only by the distance "s" from the sensing surface of the sensor. When damping in the radial direction, the location of the switching point is additionally affected by the radial distance "r" of the target from the system axis. The diagram shows the response curves, which indicate the dependency of the switching point on "s" and "r". The primary purpose of this drawing is to show the possibility of damping using a lateral approach and the difference compared with axial approach.

Application

Due in part to manufacturing tolerances within a production run, the exact switchpoint must in any case be established on site. The solid curves indicate the respective turn-on point, the dashed curves the turn-off point A. The blue curves apply to switches with a clear zone, and the black ones for flush-mountable switches. Since the switching operation can be induced from either direction, the curves are shown mirrored from the system axis.

Examples

Passing objects on conveyor lines generate a signal change when their front edge crosses the turn-on curve on the entry side. The signal reverses again when the back edge of the passing object crosses the (mirrored) turn-off curve on the opposite side. In the case of reversing parts (e. g. end of travel), the signal reversal occurs at the turn-off curve on the same side.

The vertical axis in the diagram shows the distance of the switching point from the sensing surface. It is based on the rated switching distance s_n . At a distance of 0.8 mm, a laterally approaching target reaches the solid line turn-on curve at point "E" and leaves the turn-off curve at point "A". The horizontal axis in the graph is referenced to the radius of the sensing surface. The zero point of this axis lies in the center of the shell core cap. In our example for the M12 switch, the radius is $r = 6$ mm.

10 | Sensors

Switching distances

Switching distance

The distance between the standard target and the sensing surface of the sensor at which a signal change is triggered as per EN 60947-5-2. For a normally open switch this means from OFF to ON and for normally closed from ON to OFF.

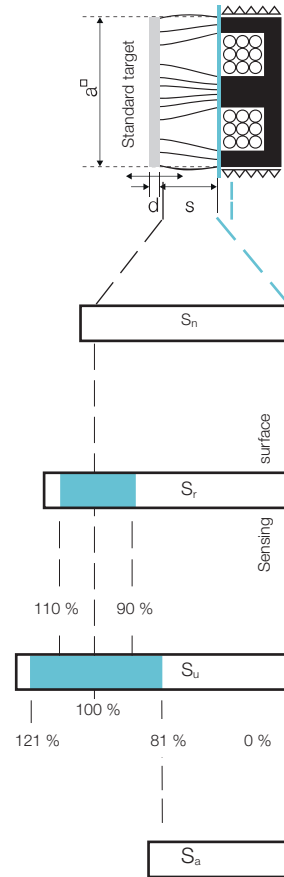

Assured switching distance S_a

Switching distance within which assured operation of the sensor at a specified voltage and temperature range is given ($0 \leq s_a \leq 0.81 s_n$).

Effective operating distance s_r

The switching distance of a single proximity switch measured under specified conditions, e.g. flush mountable, rated operating voltage U_e , temperature T_a .

Rated operating distance S_n

Maximum achievable switching distance from the standard target under device specification (generally with s_n as shipped from the factory).

Usable operating distance

The permissible operating distance is the permitted switching distance within fixed voltage and temperature limits ($0.81 s_n \leq s_u \leq 1.21 s_n$).

Switching distance labeling

Switching distance	Size	Switching distance
■ Standard-switching distance according to EN 60947-5-2		
■ ■ 2 x switching distance compared to standard	Ø 3 mm*	1 mm flush
	Ø 4 mm/M5*	1.5 mm flush
	Ø 6.5 mm...M30	1.5...2-x
■ ■ ■ 3x switching distance compared to standard	Ø 3 mm*	3 mm non-flush
	Ø 4 mm/M5*	5 mm non-flush
	Ø 6.5 mm...M12	2.2...3-x
	M18...M30	depending on version
■ ■ ■ ■ 4x switching distance compared to standard		

*Information for switching distance in mm. The switching distances of these sensors are not standardized.

Repeat accuracy

Variance in the output values when approaching a mechanically prescribed position repeatedly from the same direction.

Hysteresis

Signal difference resulting for measurement sensors when a mechanically prescribed position is approached from one side, then crosses this point and afterwards approaches this same position from the other direction. Position difference between switching point (object approaches) and switch-back point (object travels away) for switching sensors.

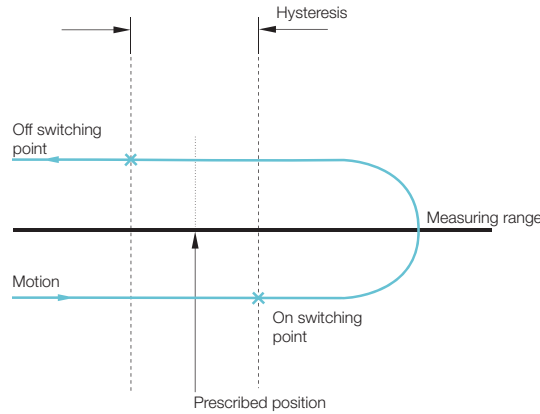

Installation in metal: Sensors with standard switching distance ■

Flush mountable sensors

Flush mountable sensors can be installed with their sensing surfaces flush to the metal. The distance to the opposite metal surfaces has to be $\geq 3 s_n$, and the distance between two sensors (with row mounting) has to be $\geq 2d$.

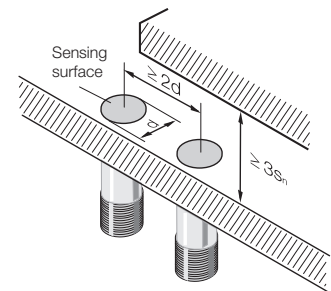

Non-flush mountable sensors

Non-flush mountable sensors can be identified by their "caps", since they have no metal housing surrounding the area of the sensing face. The sensing surface must extend $\geq 2 s_n$ from the metallic installation medium. The distance to the opposite metal surfaces has to be $\geq 3 s_n$, and the distance between two sensors (with row mounting) has to be $\geq 3 d$.

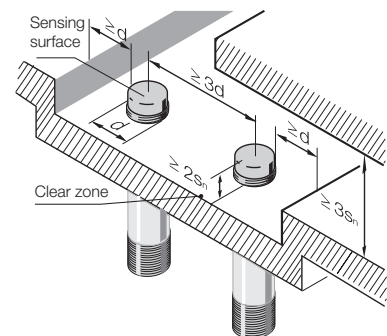

Opposing installation of two sensors

The opposing (facing) installation of two sensors requires a minimum distance of $a \geq 3d$ between the sensing faces.

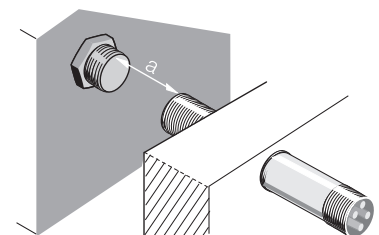

Installation medium

Materials	Description
Ferromagnetic materials	Iron, steel or other magnetizable materials
Non-ferrous metal	Brass, aluminum or other non-magnetizable materials
Other materials	Plastics, electrical non-conductive materials

Installation in metal: Sensors with 2 × switching distance ■■

Flush mountable sensors

Flush mountable sensors can be embedded flush up to their sensing surfaces in non-ferrous materials. Installation in non-ferrous metal may result in a reduction of the switching distance. The distance to the opposite metal surfaces has to be $\geq 3 s_n$, and the distance between two sensors (with row mounting) has to be $\geq 2d$. In order to install the sensor in ferromagnetic materials, the following guidelines are used for dimension "x".

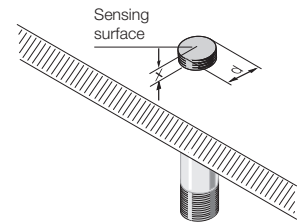
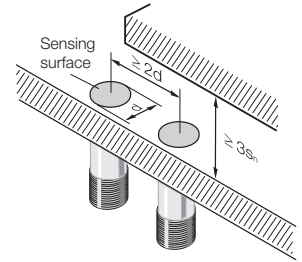

Size d	Dimension x
Ø 3 mm	1 mm
Ø 4 mm	1.5 mm
M5	1.5 mm
Ø 6.5 mm	0 mm
M8	0 mm
M12	1.5 mm
M18	2.5 mm
M30	3.5 mm

For DC 2-wire sensors, the following apply:

Size d	Dimension x
M8	0 mm
M12	0 mm
M18	0.7 mm
M30	3.5 mm

In the Factor 1 and ATEX NAMUR sensor family, dimension x is not needed when installing in metal.

Non-flush mountable sensors

Non-flush mountable sensors can be identified by their "caps", since they have no metal housing surrounding the area of the sensing face. The sensing face must extend $\geq 2 s_n$ from the metallic installation medium. The distance to the opposite metal surfaces must be $\geq 3 s_n$, and the distance between two sensors (with row mounting) has to be $\geq 3 d$.

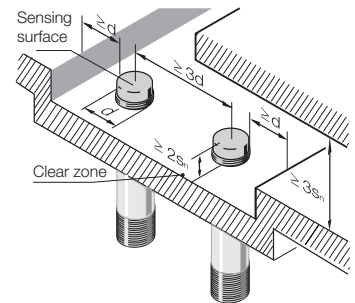

Oposing installation of two sensors

The opposing installation of two sensors requires a minimum distance of $a \geq 4d$ between the sensing surfaces.

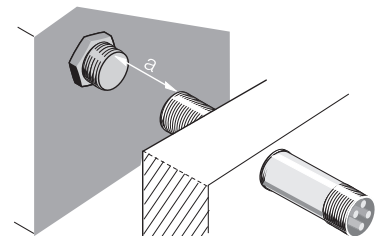

Installation in metal: Sensors with 3 × and 4 × switching distance ■■■ and ■■■■

Quasi-flush mountable sensors

Quasi-flush mountable sensors require space behind the sensing surface which is free of conductive materials. Under this condition the specified switching distance is available without limitation. Dimension "x" (see fig.) indicates the shortest distance between the sensing face and the conductive material behind it.

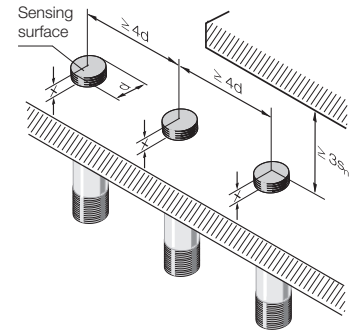

Size d	3x switching distance: Dimension x for installation in		4x switching distance: Dimension x for installation in	
	Ferromagnetic material	Other metals	Ferromagnetic material	Other metals
Ø 6.5 mm	2 mm	1 mm	3 mm	2 mm
M8	2 mm	1 mm	3 mm	2 mm
M12	2.5 mm	2 mm	4 mm	3 mm
M18	4 mm	2.5 mm		
M30	8 mm	4 mm		

Non-flush mountable sensors

Non-flush mountable sensors can be identified by their "caps", since they have no metal housing surrounding the area of the sensing face. The distance to opposing metal surfaces must be $\geq 3 s_n$.

Installation conditions:

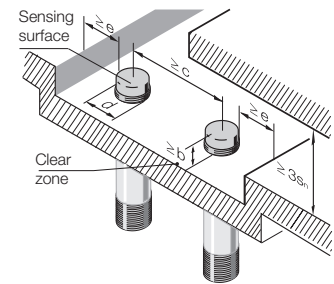

Size d	Dimension x	Dimension x	Dimension x
Size d	Dimension b	Dimension c	Dimension e
Ø 3 mm	≥ 10 mm	≥ 30 mm	≥ 10 mm
Ø 4 mm	≥ 15 mm	≥ 40 mm	≥ 20 mm
M5	≥ 15 mm	≥ 40 mm	≥ 20 mm
Ø 6.5 mm	≥ 8 mm	≥ 32 mm	≥ 8 mm
M8	≥ 8 mm	≥ 32 mm	≥ 8 mm
M12	≥ 10 mm	≥ 48 mm	≥ 12 mm
M18	≥ 20 mm	≥ 72 mm	≥ 18 mm
M30	≥ 35 mm in steel ≥ 25 mm in non-ferrous metal ≥ 20 mm in stainless steel	≥ 120 mm	≥ 30 mm

Opposing installation of two sensors

The opposing installation of two sensors requires a minimum distance of a $\geq 5d$ between the sensing surfaces.

For exceptions see table:

Size d	Dimension a
Ø 3 mm	20 mm
Ø 4 mm	45 mm
M5	45 mm

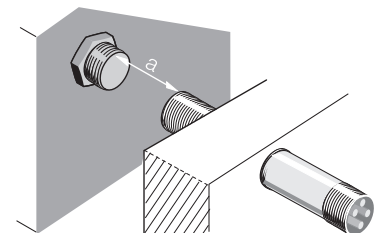

Installation instructions for block-style designs and sensors with special properties

Recommendation for gluing in the sensor Ø 6.5 mm smooth

Prepare and clean drill hole and sensor according to the specifications of the glue used. Coat hole and sensor with adhesive and position sensor in hole. Allow to cure. For additional instructions, see the data sheet.

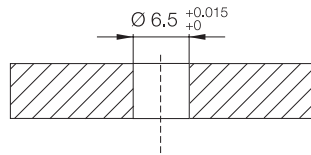

Features

- Simple installation with glue-in sensor
- Flexible use with optional radial cable outlet

Installation notice for BES R04... with s_n 2.5 mm

Aluminum: can be mounted completely flush
 Steel: all the way around with a 1.5 mm clear zone

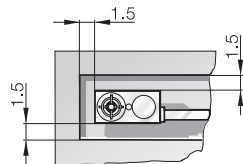

Mounting bracket BAM00K3 for BES R04... with s_n 1.5 mm (please order separately)

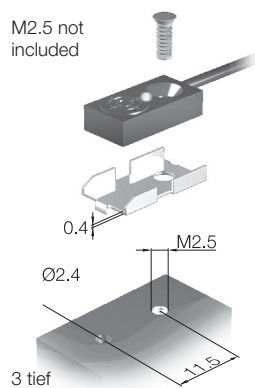

Installation note for BES030E and BES030F

Small, compact block sensor with increased switching distance for quick installation. The connector mount can be rotated and the sensing face can be oriented in three directions.

Simple replacement with no loss of position thanks to the fixed mounting plate:

- Cost savings
- No special tools necessary
- Simple to install

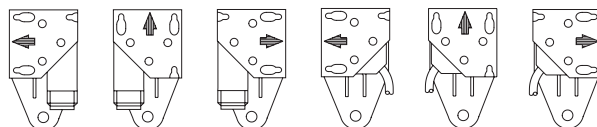

Installation note for
BES R05KB...

Row mounting

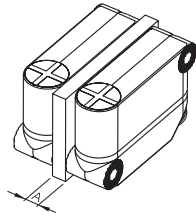

- With plastics or no material present in the space:
- Distance A = at least 5 mm
- With metal in the space:
- Distance A = at least 4 mm

Installation note
for 40 × 40 mm series
Unicomact

Flush
installation

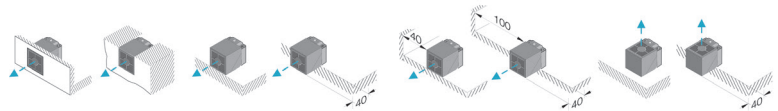

Sensing distance	Mounting	Permissible installation options									
15 mm	Original mounting bracket (plastic)	■	■	■	■	■	■	■	■	■	■
	Mounting bracket BES Q40-HW-2 (metal)	■	■	■	■	■	■	■	■	■	■
20 mm	Original mounting bracket (plastic)	■	■	■	■	■	■	■	■	■	■
	Mounting bracket BES Q40-HW-2 (metal)	■	■	■	■	■	■	■	■	■	■

Non-flush
installation

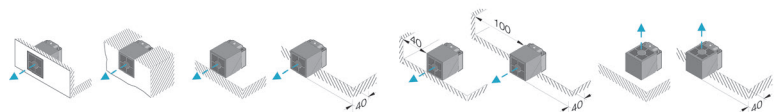

Sensing distance	Mounting	Permissible installation options									
25 mm	Original mounting bracket (plastic)			■	■	■	■	■	■	■	■
	Mounting bracket BES Q40-HW-2 (metal)			■	■	■	■	■	■	■	■ ³⁾
35 mm ¹⁾	Original mounting bracket (plastic)				■		■				■
	Mounting bracket BES Q40-HW-2 (metal)				■		■				
35 mm ²⁾	Original mounting bracket (plastic)			■	■	■	■	■	■	■	■
	Mounting bracket BES Q40-HW-2 (metal)				■		■				■ ³⁾
40 mm	Original mounting bracket (plastic)				■		■				■
	Mounting bracket BES Q40-HW-2 (metal)				■		■				

¹⁾ with BES ...35E... ²⁾ with BES ...35Z...011 ³⁾ Switching distance can be reduced by 15 %

Row mounting

80 mm flush
120 mm non-flush

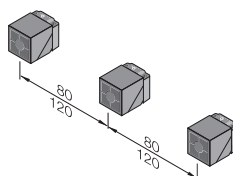

**Installation note
for 40 × 40 mm series
Unisensor**

Flush
installation

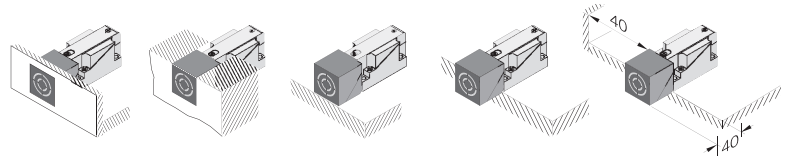

Sensing distance	Permissible installation options				
15 mm	■	■	■	■	■
20 mm	■	■	■	■	■

Row mounting

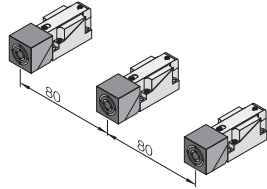

Non-flush
installation

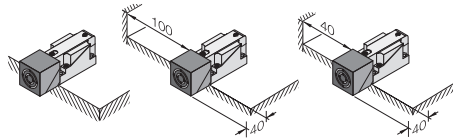

Sensing distance	Permissible installation options		
20 mm	■	■	■
25 mm	■	■	■
30 mm	■	■	■
40 mm	■	■	■

Row mounting

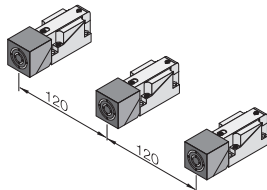

**Installation note
for 80 × 80 mm series
Maxisensor**

Flush
installation

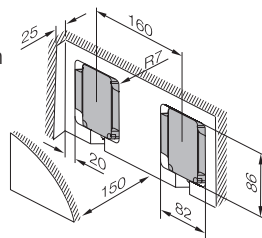

Non-flush
installation

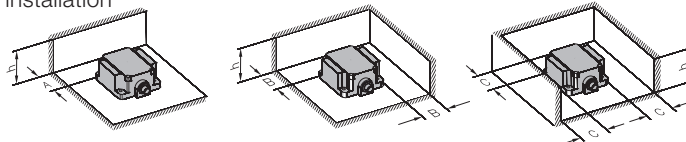

Minimum distances in metal

Metal/measurements	h	A	B	C
Stahl	40 mm	70 mm	80 mm	90 mm
Stahl	70 mm	80 mm	90 mm	100 mm
Aluminum	40 mm	0 mm	10 mm	10 mm
Aluminum	70 mm	10 mm	20 mm	20 mm

Please note whether it is installed in ferrous or non-ferrous materials.

Installation instruction for high pressure rated sensors with O-ring

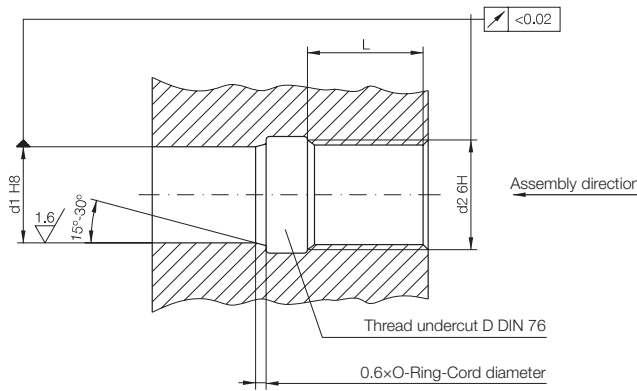

For example, with BHS0035:

- d₁: Ø of the positioning hole for the switch head $\text{Ø } 10^{\text{H8}} = \text{Ø } 10^{+0,022}$
- d₂: Nominal thread diameter M12 × 1 6H
- L: Recommended screw-in depth $L \geq 0.8 \times d_2 = 0.8 \times 12 = 9.6$

Installation note for ring sensors

Installation in row

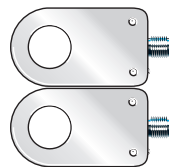

Installation in a stack

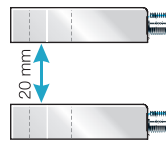

Installation note hose sensors

Centerline spacing for side-by-side mounting

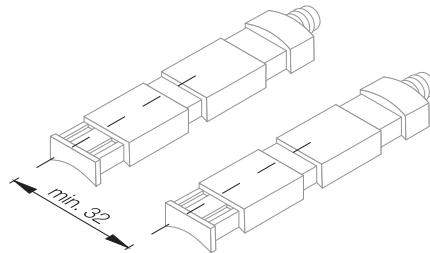

Mechanical features

General tolerances

In general, the variances in external dimensions, form, and position tolerances of Balluff products fall within the general tolerance in accordance with DIN ISO 2768-cK. Important functional dimensions are indicated with specific tolerances in the product view. For all other dimensions without a specific tolerance specified, the general tolerance per DIN ISO 2768-cK applies.

Limit deviations for linear dimensions: Tolerance class c

Tolerance class	From 0.5 until 3	Over 3 until 6	Over 6 until 30	Over 30 until 120	Over 120 until 400	Over 400 until 1000	Over 1000 until 2000	Over 2000 until 4000
c (coarse)	±0.2	±0.3	±0.5	±0.8	±1.2	±2	±3	±4

Straightness and flatness: Tolerance class K

Tolerance class	Until 10	Over 10 until 30	Over 30 until 100	Over 100 until 300	Over 300 until 1000	Over 1000 until 3000		
K	0.05 mm	0.1 mm	0.2 mm	0.4 mm	0.6 mm	0.8 mm		

INDUCTIVE DISTANCE SENSORS WITH ANALOG OUTPUT

Distance sensor with analog output

A sensor which generates a continuously varying output signal which is a function of the distance between the sensing surface and the actuation element.

Effective distance s_e

Point in the middle of a sensor's range of linearity s_l . Serves as a reference point for further specifications.

Linearity range

Working range in which the sensor has defined linearity.

Linearity error

Maximum deviation from the straight line that connects the zero point of the measuring range to the end point or full extension. There is a linear relationship between the position or path to be measured and the output signal for a voltage, current or digitized output information. This feature may be restricted to a defined linearity range.

Limit frequency

Maximum possible number of switching operations per second. Damping is done according to EN 60947 -5-2 with standard targets on a rotating, non-conductive disc. The area ratio of iron to non-conductor is 1:2. The rated value of the limit frequency (-3 dB limit) is reached when the output signal has dropped to approx. 70% of the original signal level.

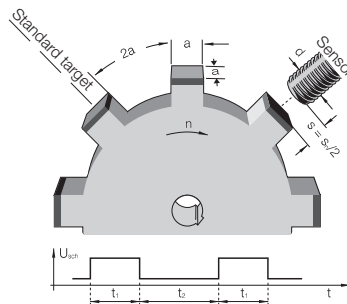

Measurement speed

Speed with which changes to the active surface of a sensor are registered, processed and outputted. Up to the specified measuring speed the distance to a linear moving object can be reliably detected. The direction of movement of the object is parallel to the sensing face of the sensor.

Repeat accuracy

Variance in the output values when approaching a mechanically prescribed position repeatedly from the same direction.

Response time

The time which a sensor requires in order to reliably and steadily change the output signal. The specified time, which was determined at the maximum measuring speed, includes both the electrical response time of the sensor and the time for the mechanical change of the damping state.

Slope

The slope is a measure of the sensitivity of the sensor with respect to a distance change. This physical relationship can be calculated for travel sensors as follows:

$$\text{Slope } S \text{ [V/mm]} = \frac{U_{a \text{ max}} - U_{a \text{ min}}}{s_{a \text{ max}} - s_{a \text{ min}}}$$

or

$$\text{Slope } S \text{ [mA/mm]} = \frac{I_{a \text{ max}} - I_{a \text{ min}}}{s_{a \text{ max}} - s_{a \text{ min}}}$$

Temperature drift

The temperature drift is the shift a point experiences on the actual output curve at different temperatures. The temperature drift is described by the temperature coefficient.

Temperature coefficient

Describes the deviation of the sensor output signal under the effect of a temperature change, and thus represents a quality criterion for the sensor also.

Tolerance T

A variable which defines the manufacturing tolerance band of the output curve, thereby determining the maximum sample deviation.

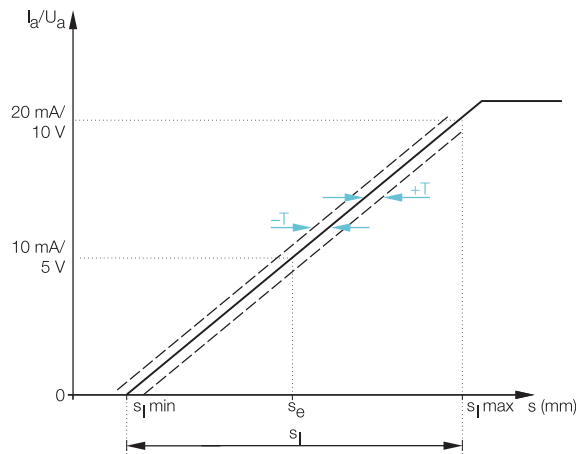

Size	Tolerance for flush sensors	Tolerance for non-flush sensors
Ø 6.5 mm	±0.125 mm	
M8	±0.1 mm	±0.15 mm
M12	±0.125 mm	±0.25 mm
M18	±0.3 mm	±0.5 mm
M30	±0.6 mm	±0.8 mm
PG 36	±0.1 mm	
20×30×8 mm	±0.125 mm	
80×80×40 mm	±1.0 mm	

Installation note for BAW R03K...

Material	Installation dimensions x
Steel	0 mm
Brass	5 mm
Aluminum	5 mm
Stainless steel	5 mm

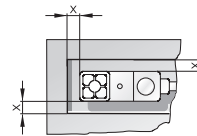

Installation note for Analog-Ringsensor

Compact analog ring sensor with 20 mm opening. Measured value changes are produced by different metallic objects or insertion depths. Applications include thickness measurement of various screws, rods or wires, and position measurement on machines by inserting conical objects into the sensor.

Testing cone for determining insertion depth (measuring range and linearization)

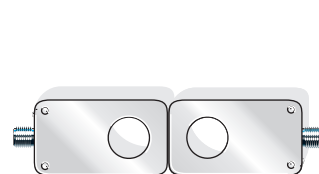
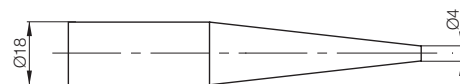

No mutual interference for front-mounting of two sensors.

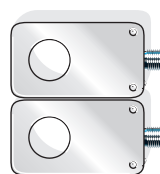

No mutual interference for parallel mounting of two sensors.

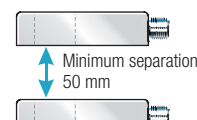

When stacking multiple sensors, the separation must be at least 50 mm.

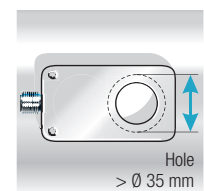

The opening should be at least Ø 35 mm for flat installation on metal surfaces.

ACCESSORIES FOR INDUCTIVE SENSORS

**Mounting options
for inductive sensors
40 × 40 mm**

Mounting bracket BAM00JW

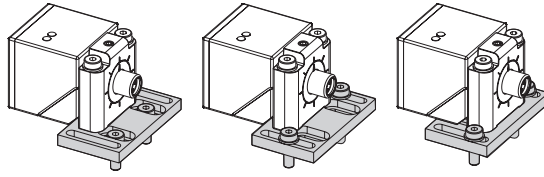

Three different mounting options

Fastener set BAM026J

- 1 mounting plate
- 2 slot nuts
- 2 cheese head screws M5 × 10 DIN 912
- 2 washers Ø 5.3, DIN 533
- 2 cheese head screws M5 × 40, ISO 4762

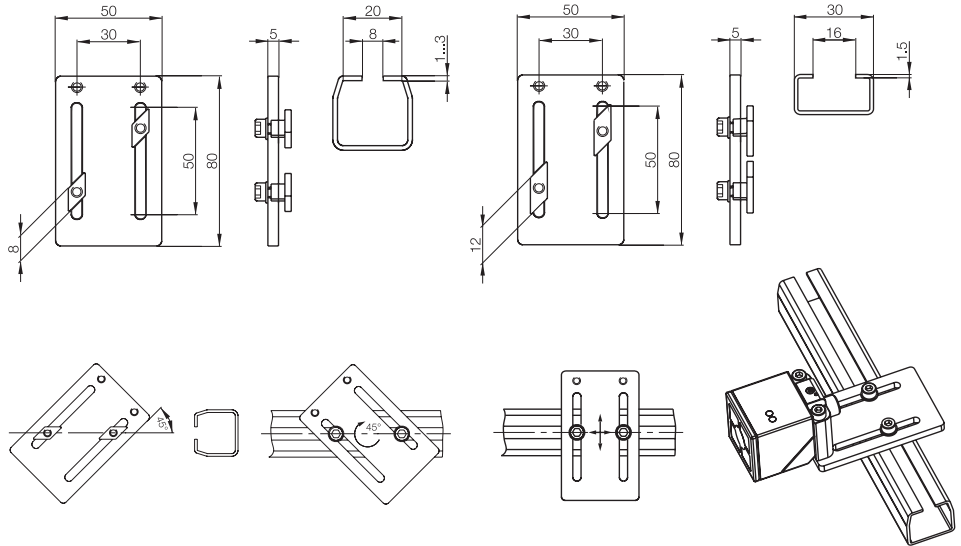

**Weld protection
for inductive sensors
40 × 40 mm**

The BAM00K0 weld protection consists of a protective cover and a self-adhering PTFE film for protecting the active surface. If the sensor head is replaced, the welding protection must not be removed.

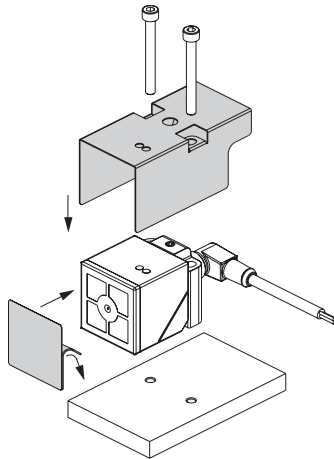

Headquarters
Balluff GmbH
Schurwaldstrasse 9
73765 Neuhausen a. d. F.
Germany

Balluff is represented in over 60 countries and regions worldwide:
www.balluff.com/go/contacts



www.balluff.com

CONTACT OUR
WORLDWIDE
SUBSIDIARIES

Disclaimer

When using this description, the user is obliged to exercise the due diligence required for use and to notify Balluff immediately in text form of any contradictions or discrepancies. In this respect, Balluff accepts no liability for technical and/or typographical errors and reserves the right to make changes to this description at any time and without notice.

After this description is provided free of charge, Balluff is liable for damages due to defects of the description or due to the violation of other contractual or non-contractual obligations only in case of intent or gross negligence. The above limitation of liability shall not apply in the case of fraudulent intent, injury to life, limb or health, in the case of the assumption of a guarantee and in the case of liability under the Product Liability Act. Any further liability of Balluff is excluded. The above limitations of liability shall also apply to the personal liability of Balluff's employees, representatives and/or bodies as well as to all vicarious agents of Balluff.

Before use in systems and machines, check whether the description provided here free of charge is suitable for your application.

By using the description provided here free of charge, you accept this liability regulation.