

INSTRUCTION MANUAL

FOR

NEGATIVE SEQUENCE OVERCURRENT RELAY

BE1-46N

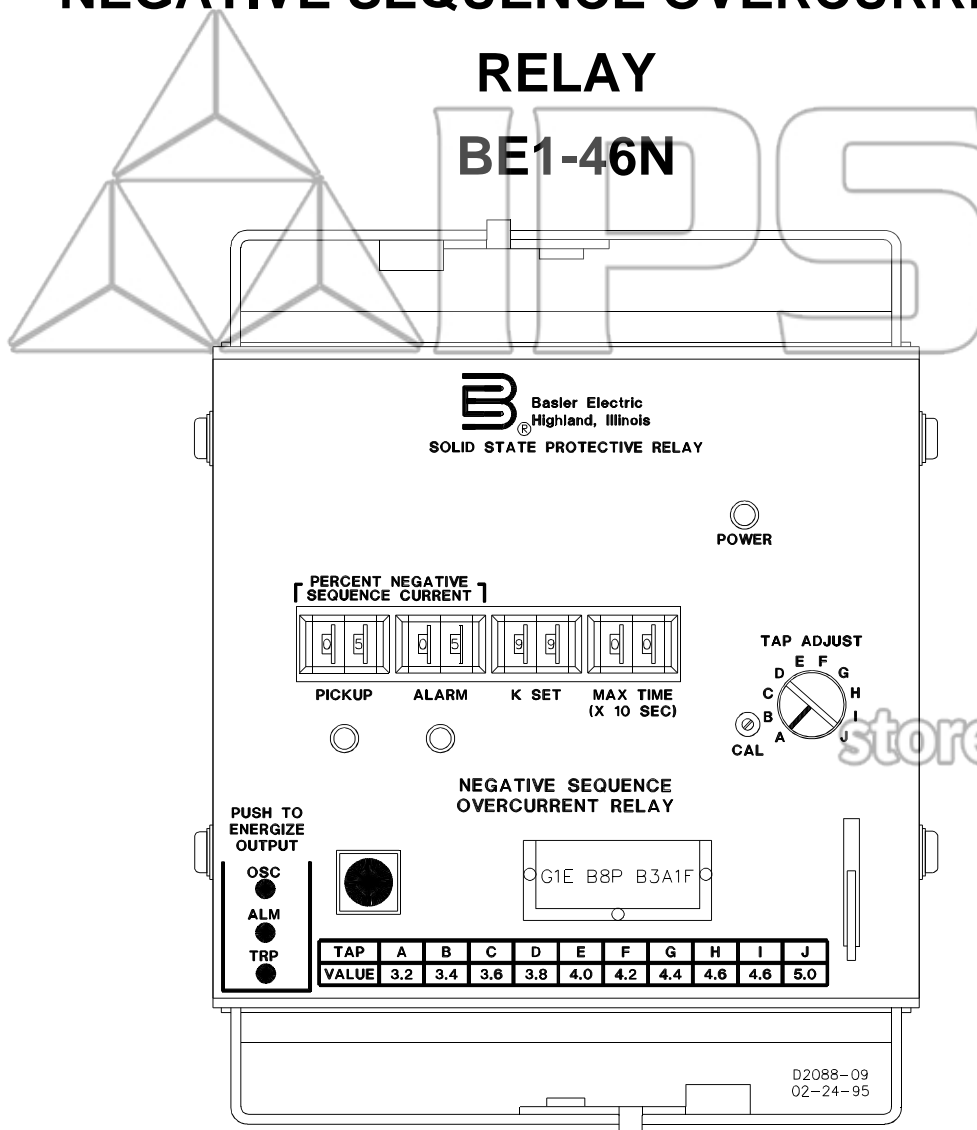

B Basler Electric

Publication Number: 9 1700 00 990
Revision: F 02/01



INTRODUCTION

This manual provides information concerning the operation and installation of the BE1-46N Negative Sequence Overcurrent Relay. To accomplish this, the following is provided.

- Specifications
- Functional Description
- Mounting Information
- Operational Test Procedure

WARNING!

TO AVOID PERSONAL INJURY OR EQUIPMENT DAMAGE, ONLY QUALIFIED PERSONNEL SHOULD PERFORM THE PROCEDURES PRESENTED IN THIS MANUAL.

First Printing: May 1985

Printed in USA

© 1995, 1998, 2001 Basler Electric Co., Highland, IL 62249

February 2001

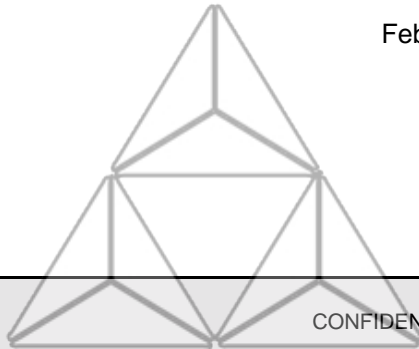

IPS

CONFIDENTIAL INFORMATION

OF BASLER ELECTRIC COMPANY, HIGHLAND, IL. IT IS LOANED FOR CONFIDENTIAL USE, SUBJECT TO RETURN ON REQUEST, AND WITH THE MUTUAL UNDERSTANDING THAT IT WILL NOT BE USED IN ANY MANNER DETRIMENTAL TO THE INTEREST OF BASLER ELECTRIC COMPANY.

store.ips.us

It is not the intention of this manual to cover all details and variations in equipment, nor does this manual provide data for every possible contingency regarding installation or operation. The availability and design of all features and options are subject to modification without notice. Should further information be required, contact Basler Electric Company, Highland, Illinois.

**BASLER ELECTRIC
ROUTE 143, BOX 269
HIGHLAND, IL 62249 USA**

<http://www.basler.com>, info@basler.com

PHONE 618-654-2341

FAX 618-654-2351

CONTENTS

SECTION 1	GENERAL INFORMATION	1-1
	Description	1-1
	Principles of Symmetrical Operation	1-1
	Model and Style Number	1-1
	Style Number Example	1-2
	Style Number Identification Chart	1-2
	Specifications	1-3
SECTION 2	HUMAN-MACHINE INTERFACE	2-1
	Controls and Indicators	2-1
SECTION 3	FUNCTIONAL DESCRIPTION	3-1
	General	3-1
	Input Sensing	3-1
	Measuring I_2	3-1
	Microprocessor	3-2
	Program Monitor	3-2
	Outputs	3-2
	Power Supply	3-2
	Power Supply Status Output	3-3
	Setting Consideration	3-3
	I_n Reference Level (Tap Value)	3-4
	Alarm and Pickup	3-4
	K Setting	3-4
	MAX TIME	3-4
	Calculation Example	3-5
	Setting Tap Adjust	3-5
	Method 1, Single-Phase	3-5
	Method 2, Three-Phase	3-6
	Further Considerations	3-7
	Characteristic Curves	3-8
SECTION 4	INSTALLATION	4-1
	General	4-1
	Relay Operating Precautions	4-1
	Dielectric Test	4-1
	Mounting	4-1
	S1 Case, Outline Dimensions, Front View	4-2
	S1 Case, Panel Drilling Diagram, Semi-Flush Mounting	4-3
	S1 Case, Outline Dimensions, Rear View	4-4
	S1 Case, Semi-Flush Mounting, Side View	4-5
	S1 Case, Panel Drilling Diagram, Projection Mounting	4-6
	S1 Case, Projection Mounting, Side View	4-7
	Remote Meter Dimensions and Drilling Diagram	4-8
	Connections	4-8
	Typical DC Control Connections	4-9
	Typical AC Sensing Connections	4-10
	Typical Internal Connections	4-11

CONTENTS - Continued

SECTION 5	TESTING	5-1
	General	5-1
	Testing	5-1
	Operational Test Procedure	5-1
	Pickup and Alarm	5-1
	Timing	5-2
	MAX TIME	5-3
SECTION 6	MAINTENANCE	6-1
	General	6-1
	In-House Repair	6-1
	Storage	6-1
SECTION 7	MANUAL CHANGE INFORMATION	7-1
	Summary and Cross Reference Guide	7-1

store.ips.us

SECTION 1 • GENERAL INFORMATION

DESCRIPTION

BE1-46N Negative Sequence Overcurrent Relays are three-phase solid state relays designed to provide protection for generators and motors from unbalanced loading or power system faults. These relays protect the machinery from damage when the protective scheme or other equipment, external to the generator, fails to eliminate the unbalanced condition.

BE1-46N Negative Sequence Overcurrent Relays accurately monitor the magnitude and control the duration of the negative sequence current component. These relays incorporate a time delay that replicates the machinery heating and cooling characteristics. An alarm element in the relays may be used to provide time to locate and isolate the fault. Doing this avoids damage to the machinery, prevents an undesired trip, and precludes a potentially prolonged outage of the machinery.

BE1-46N relays are designed for use with any poly-phase generating system having known $(I_2)^2t$ limits between 1 and 99. Relays that operate using phase currents to determine the negative sequence component are phase rotation sensitive. BE1-46N relays are phase rotation sensitive.

PRINCIPLES OF SYMMETRICAL COMPONENTS

Principles of symmetrical components allow an unbalanced system to be considered as three separate, balanced subsystems. These balanced subsystems may then be analyzed as single phase quantities. These quantities are the positive, negative, and zero sequence components of current and voltage.

The positive sequence component of current (I_1) represents the portion of the total current which has normal phase rotation and produces no adverse effect on the system. An ideally balanced system contains only positive sequence phase currents and voltages.

The zero sequence component of current (I_0) also has no adverse effect on a three-phase, three-wire (no neutral connection) power system because it produces no appreciable magnetic flux and causes no excessive heating in the generator rotor or windings.

The negative sequence component of current (I_2) produces a magnetic flux in the stator that has the same rotational speed as the rotor flux, but in the opposite direction. This causes the stator magnetic flux to rotate at twice the system frequency and induce eddy currents into the rotor. These eddy currents create excessive heat in the rotor iron and windings, and, if allowed to persist, could result in severe damage to the system.

MODEL AND STYLE NUMBER

Electrical characteristics and operational features included in a specific relay are defined by a combination of letters and numbers that constitute the device style number. The model number, BE1-46N, designates the relay as a Basler Electric Class 100 Negative Sequence Overcurrent Relay. The style number together with the model number describe the features and options in a particular device and appear on the front panel, drawout cradle, and inside the case assembly.

Style Number Example

The following style number identification chart illustrates the features and options for BE1-46N relays. For example, if the style number were **BE1-46N G1H B8S B1B1F**, the relay would have the following features:

- BE1-46N** Model number.
- G** Three-phase negative sequence current sensing.
- 1** Sensing input range of 3.0 to 5.0 A nominal at 60 hertz.
- H** Alarm output relay contacts NC and trip output relay contacts NO.
- B8** $(I_2)^2t$ timing characteristics.
- S** Field selectable 48 or 125 Vdc power supply.
- B** One current operated target for the trip circuit.
- 1** A remote meter for monitoring I_2 levels is supplied.
- B** An oscillograph start function with NC contacts.
- 1** An auxiliary output relay with NO contacts.
- F** Semi-flush mounting.

Style Number Identification Chart

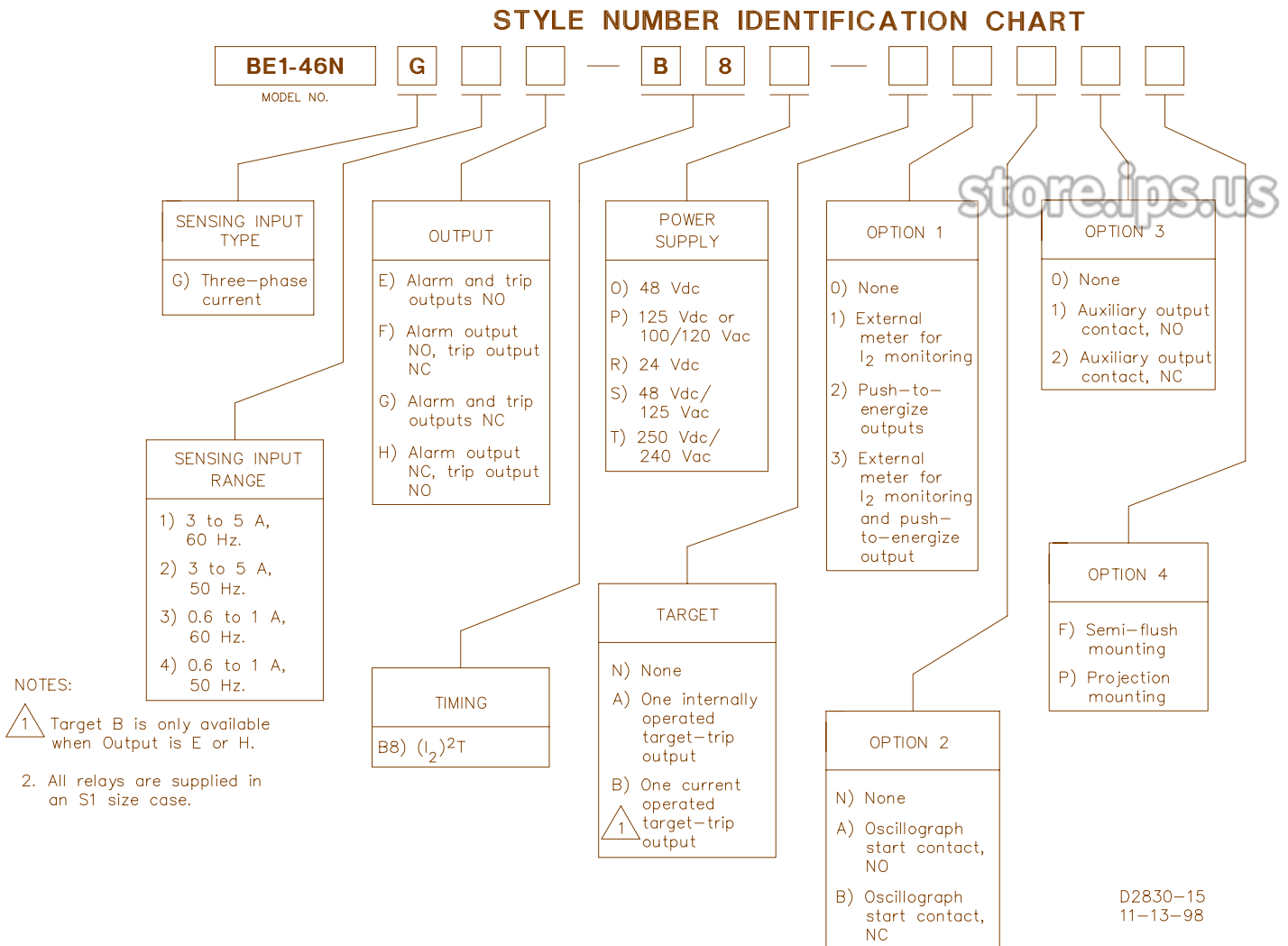

Figure 1-1. Style Number Identification Chart

SPECIFICATIONS

Current Sensing

(5 Ampere CT)

5 amperes nominal (50/60 hertz) current transformers; 10 amperes continuous current, 250 amperes one second current, 2 VA burden maximum per phase, frequency range 45 to 55 hertz for 50 hertz systems and 55 to 65 hertz for 60 hertz systems.

(1 Ampere CT)

1 ampere nominal (60 hertz) current transformers; 2 ampere continuous current, 50 ampere one second current, 2 VA burden maximum per phase, frequency range 60 ±5 hertz.

Power Supply

Power for the internal circuitry may be derived from ac or dc external power sources.

Type	Nominal Input Voltage	Input Voltage Range	Burden at Nominal (Maximum)
O (Mid Range)	48 Vdc	24 to 150 Vdc	5.5 W
P (Mid Range)	125 Vdc 120 Vac	24 to 150 Vdc 90 to 132 Vac	6.0 W 16.0 VA
R (Low Range)	24 Vdc	12† to 32 Vdc	5.5 W
S (Mid Range)	48 Vdc 125 Vdc	24 to 150 Vdc 24 to 150 Vdc	5.5 W 6.0 W
T (High Range)	250 Vdc 240 Vac	62 to 280 Vdc 90 to 270 Vac	7.0 W 16.0 VA

† Type R power supply initially requires 14 Vdc to begin operating. Once operating, the voltage may be reduced to 12 Vdc and operation will continue.

Output Circuits

Output contacts are rated as follows:

Resistive:

120/240 Vac

Make 30 amperes for 0.2 seconds, carry 7 amperes continuously, and break 7 amperes.

250 Vdc

Make 30 amperes for 0.2 seconds, carry 7 amperes continuously, and break 0.3 ampere.

Inductive:

120/240 Vac,
125/250 Vdc

Make 30 amperes for 0.2 seconds, carry 7 amperes continuously, and break 0.3 ampere. (L/R = 0.04).

Oscillograph Start

0.5 ampere at 48 Vdc.

Target Indicators

Targets may be specified as either internally operated, or current operated by a minimum of 0.2 ampere through the output trip circuit. When current operated, the output circuit must be limited to 30 amperes for 0.2 seconds, 7 amperes for 2 minutes, and 3 amperes continuously.

TAP ADJUST Selection Range

(5 Ampere CT)

Continuously adjustable over the range of 3.0 amperes to 5.0 amperes. This adjustment establishes the full load reference level (I_N) for the application.

(1 Ampere CT)

Continuously adjustable over the range of 0.6 A to 1.0 A. This adjustment establishes the full load reference level (I_N) for the application.

PICKUP Selection Range Adjustable over the range of 1 to 50% in increments of 1%.

PICKUP Measuring Accuracy $\pm 0.5\%$ of I_2 .

PICKUP Dropout Ratio Better than 98% of pickup.

ALARM Selection Range Adjustable over the range of 1 to 50% in increments of 1%.

ALARM Pickup Measuring Accuracy $\pm 0.5\%$ of I_2 .

ALARM Time Delay Factory set at 3.0 seconds.

ALARM Dropout Ratio Better than 98% of ALARM pickup level.

K SET Timing Accuracy $\pm 5\%$ of the selected curve.

Minimum Trip Timer Accuracy 200 ± 25 milliseconds.

MAX TIME (X 10 SEC) Selection Range Adjustable over the range of 10 to 990 seconds in increments of 10 seconds.

MAX TIME Accuracy $\pm 5\%$ of the setting.

Radio Frequency Interference (RFI) Field tested using a five watt, hand-held transceiver operating at random frequencies centered around 144 megahertz and 440 megahertz, with the antenna located six inches from the relay in both horizontal and vertical planes.

Fast Transient Qualified to ANSI/IEEE C37.90.1-1989.

Isolation In accordance with ANSI/IEEE C37.90-1989 one minute dielectric (high potential) test as follows:

All circuits to ground: 2121 Vdc.
Input to output circuits: 1500 Vac or 2121 Vdc.

Surge Withstand Capability Qualified to ANSI/IEEE C37.90.1-1989 Standard *Surge Withstand Capability (SWC) Tests for Protective Relays and Relay Systems*.

Shock In standard tests, the relay has withstood 15 g in each of three mutually perpendicular planes without structural damage or degradation of performance.

Vibration:

In standard tests, the relay has withstood 2 g in each of three mutually perpendicular planes, swept over the range of 10 to 500 hertz for a total of six sweeps, 15 minutes each sweep, without structural damage or degradation of performance.

UL Recognized

UL Recognized per Standard 508, UL File No. E97033. Note: Output contacts are not UL Recognized for voltages greater than 250 volts.

Operating Temperature

-40°C (-40°F) to 70°C (158°F).

Storage Temperature

-65°C (-85°F) to +100°C (+212°F).

Weight

13.5 pounds maximum.

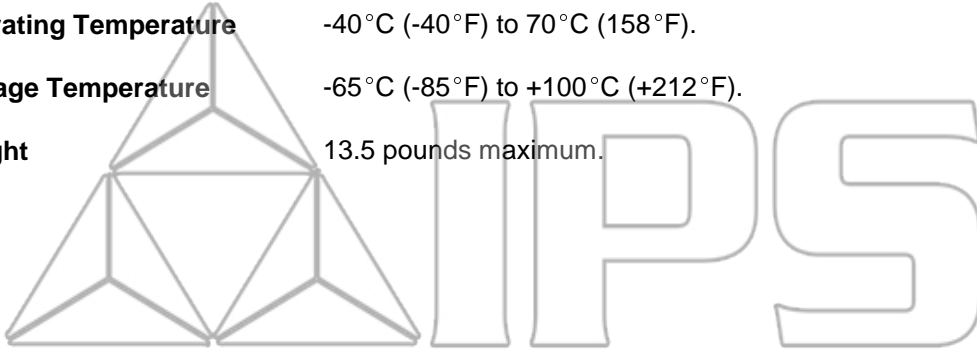

store.ips.us

SECTION 2 • HUMAN-MACHINE INTERFACE

CONTROLS AND INDICATORS

Table 2-1. BE1-46N Controls and Indicators (Refer to Figure 2-1)

Locator	Control or Indicator	Function
A	PICKUP (Trip Level)	Front-panel thumbwheel switch provides selection of the negative sequence overcurrent pickup point that, when exceeded, initiates timing. Setting is continuously adjustable over the range of 1 to 50% in increments of 1%. A setting of 00 will be recognized as 1%. Any setting beyond 50 will be recognized as 50%.
B	ALARM (Trip Level)	Front-panel thumbwheel switch provides selection of the pickup point for the ALARM trip level and is continuously adjustable over the range of 1 to 50% in increments of 1%. A setting of 00 will be recognized as 1%. Any setting beyond 50 will be recognized as 50%.
C	K SET	Front-panel thumbwheel switch provides adjustment of the relay timing characteristic over the range of 1 to 99 in increments of 1. Allows the relay to match the characteristics of the protected machine. See Figure 3-2 for characteristic curves. A setting of 00 will be recognized as a K-setting of 100.
D	MAX TIME (X 10 SEC)	Front-panel thumbwheel switch provides selection of the maximum trip time over the range of 10 to 990 seconds in increments of 10 seconds. Refer to Figure 3-2 for characteristic curves. A setting of 00 will be recognized as 1000 seconds.
E	POWER LED	LED illuminates when proper operating power is applied to the relay internal circuitry.
F	TAP ADJUST	Front panel mounted, 10-position rotary switch establishes the full-load current reference level (I_N) for the application. The 5 ampere model is adjustable from 3.0 A to 5.0 A in increments of 0.2 A. The one ampere model is adjustable from 0.6 A to 1.0 A in increments of 0.04 A.
G	CAL Adjust	Provides a vernier adjustment between the selected TAP ADJUST setting and the next lower TAP ADJUST setting. A fully CW adjustment of the CAL control provides the indicated TAP ADJUST setting. CCW adjustment of the CAL control provides adjustments to the next lower setting.
H	Reset Lever	Provides manual reset of Target indicator.
I	PUSH TO ENERGIZE OUTPUT Pushbutton	Provides manual actuation of the output contacts by inserting a 1/8 inch diameter, non-conducting rod through the access hole in the front panel.
J	Trip Target Indicator	Provides visual indication that the trip output relay has energized. Must be manually reset.

Locator	Control or Indicator	Function
K	ALARM LED	LED illuminates when level of I_2 exceeds the ALARM (trip level) setting.
L	PICKUP LED	LED illuminates when level of I_2 exceeds PICKUP (trip level) setting.

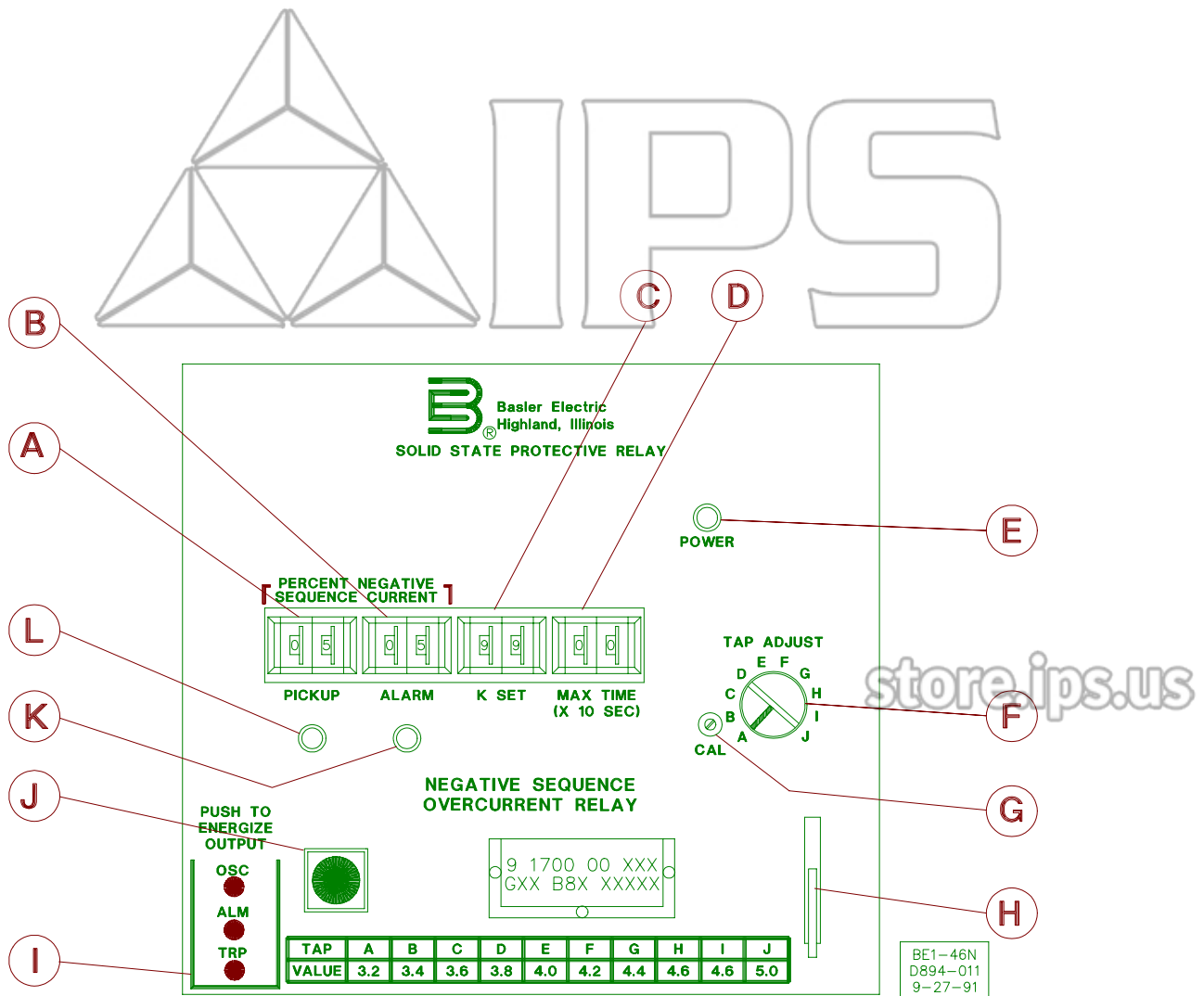

Figure 2-1. Location of Controls and Indicators

SECTION 3 • FUNCTIONAL DESCRIPTION

GENERAL

The following discussion is referenced to the Functional Block Diagram, Figure 3-1.

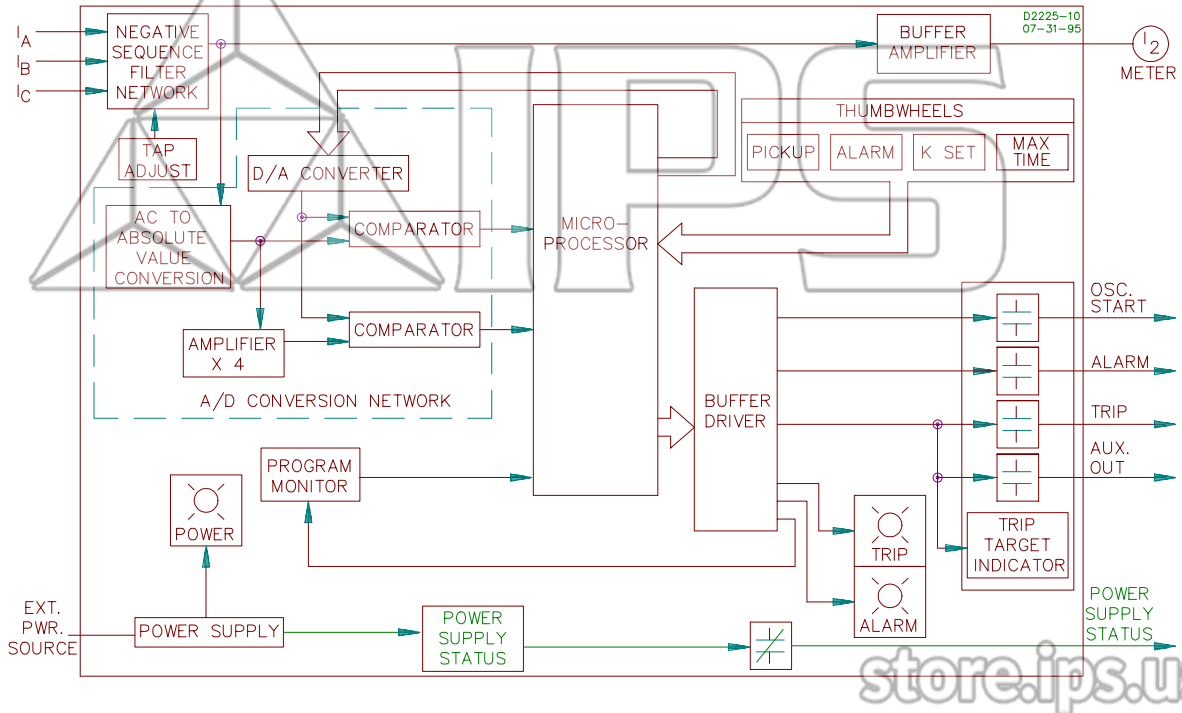

Figure 3-1. Functional Block Diagram

INPUT SENSING

Three-phase currents are applied to the negative sequence filter network which removes the zero and positive sequence components of sensed line currents.

Resolved negative sequence currents (I_2) are scaled by the TAP ADJUST switch. The TAP ADJUST switch selects resistive loading to establish per unit (pu) current values. Switch positions, A through J, select tap values from 3.2 amperes to 5.0 amperes in increments of 0.2 ampere. The CAL potentiometer is a vernier control for selecting tap values between the settings of the TAP ADJUST switch.

The output from the filter is applied to the analog to digital (A/D) conversion network and to the buffer amplifier to drive the external meter (optional) for I_2 level monitoring.

MEASURING I_2

The input from the filter network is converted to an absolute value and applied to a comparator and a times four amplifier. The amplified output is also sent to a comparator. Both the direct and amplified values are measured by the microprocessor. When I_2 values are small, the amplified output is used. This improves resolution and accuracy.

Successive approximation measuring techniques allow the microprocessor to measure the level of I_2 . A digital number with only the most significant digit set high is sent from the microprocessor to the digital to

analog (D/A) converter. The analog output from the D/A is compared with I_2 by both comparators and the results sent to the microprocessor. Based on the results of that comparison, another digital number is sent from the microprocessor to the D/A converter. The analog output is again compared with I_2 and the results sent to the microprocessor. This continues until the microprocessor number equals the I_2 value. The microprocessor then compares that number with the selected inputs from the thumbwheels. When the magnitude of I_2 exceeds the setting of the trip level, the microprocessor begins timing and calculates the $(i_2)^2 dt$. The microprocessor compares the continuously calculated value with the maximum permissible heating constant K. Tripping occurs when the calculated value exceeds the K setting. If I_2 falls below the pickup setting, the relay will reset at a linear rate of 2.5 seconds per percent of full scale trip time.

MICROPROCESSOR

BE1-46N relays use an 8-bit, low power, CMS microprocessor which controls all timing, measurements, computations, and outputs.

PROGRAM MONITOR

During power-up, the program monitor initializes program sequencing. During operation, the microprocessor outputs a series of pulses at regular intervals. The program monitor senses these pulses and, if the pulses are disrupted in any way, resets the microprocessor. Reset initializes the program sequence and provides for fail safe operation.

OUTPUTS

Output relays are provided for trip and alarm functions. An auxiliary output relay is available that operates at the same time as the trip relay. Trip and auxiliary output relays are available with either normally open (NO) or normally closed (NC) contacts. The alarm output and oscilloscope start relays are also available with NO or NC contacts. Power supply output contacts are monitored at the mother board. Normal supply voltage causes the status relay to be continually energized. However, if at any time the voltage falls below requirements, the relay drops out, and closes the normally closed contacts.

An optional remote meter calibrated to display the magnitude of I_2 is a percentage of the full load current is also available. Full scale deflection of the meter corresponds to 50%.

If this option is specified, a standard 4.5 inch switchboard type meter is available and must be ordered separately. Specify Basler Electric part number 9 1700 00 001.

NOTE

Connection between relay and meter must be made using no less than a 20 AWG, shielded, twisted pair with the shield grounded only at the relay case. (Belden Manufacturing Company part number 9962 or equivalent is recommended.)

POWER SUPPLY

Basler Electric enhanced the power supply design for unit case relays. This new design created three, wide range power supplies that replace the five previous power supplies. Style number identifiers for these power supplies have not been changed so that customers may order the same style numbers that they ordered previously. The first newly designed power supplies were installed in unit case relays with EIA date codes 9638 (third week of September 1996). Relays with a serial number that consists of one alpha character followed by eight numerical characters also have the new wide range power supplies. A benefit of this new design increases the power supply operating ranges such that the 48/125 volt selector is no longer necessary. Specific voltage ranges for the three new power supplies and a cross reference to the style number identifiers are shown in the following table.

Table 3-1. Wide Range Power Supply Voltage Ranges

Power Supply	Style Chart Identifier	Nominal Voltage	Voltage Range
Low Range	R	24 Vdc	12† to 32 Vdc
Mid Range	O, P, S	48, 125 Vdc, 120 Vac	24 to 150 Vdc, 90 to 132 Vac
High Range	T	125, 250 Vdc, 120, 240 Vac	62 to 280 Vdc, 90 to 270 Vac

† 14 Vdc required to start the power supply.

Relay operating power is developed by the wide range, isolated, low burden, flyback switching, solid-state power supply. Nominal ±12 Vdc is delivered to the relay internal circuitry. Input (source voltage) for the power supply is not polarity sensitive. A red LED turns ON to indicate that the power supply is functioning properly.

POWER SUPPLY STATUS OUTPUT

The power supply status output relay has normally closed (NC) output contacts. This relay is energized upon power-up thus opening its contacts. Normal relay operating voltage maintains the power supply status output relay continually energized and its output contacts open. However, if the power supply output voltage falls below the requirements for proper operation, the power supply status output relay de-energizes, thus closing the NC output contacts.

SETTING CONSIDERATIONS

As the generator is subjected to unbalanced currents, the heating of the generator can be expressed in terms of negative sequence current and time. The following mathematical relationship defines the permissible heat energy tolerable to the generator without causing damage:

$$\text{Heat Energy} = \int_0^T (i_2)^2 dt$$

To avoid damage to the generator, the heat energy must be less than some value K as provided by the generator manufacturer. The K value is a machine constant representing maximum permissible heating. This value varies depending upon the generator design. K values normally range from 4 to 40. The allowable heat energy is then expressed as:

$$\text{Heat Energy} = \int_0^T (i_2)^2 dt < K$$

Or, as: the instantaneous negative sequence current is equal to some constant I_2 which is expressed in per unit of full load stator current. The formula is now expressed as:

$$\text{Heat Energy} < (i_2)^2 T$$

For clarification, the following definitions are included.

- K = machine constant supplied by generator manufacturer representing the maximum permissible thermal capacity of the generator rotor
- T = time in seconds
- i_2 = instantaneous negative sequence current
- I_2 pu = negative phase sequence overcurrent expressed in per unit of full load stator current

Where:

$$I_2 \text{ per unit} = \frac{(i_2)}{\text{Full Load Stator Current}}$$

BE1-46N relays are featured with the following settings:

- TAP ADJUST and TAP ADJUST CAL to establish a reference level (full load stator current)
- ALARM and PICKUP
- K SET
- MAX TIME (X 10 SEC)

I_n Reference Level (Tap Value)

An adjustment is provided to establish the stator full load current reference level I_n . This adjustment has a range of 3.0 to 5.0 amperes. This is provided by a 10 position switch and vernier control. The switch positions are marked from position A through J and provide a TAP VALUE as follows:

A	-	3.2
B	-	3.4
C	-	3.6
D	-	3.8
E	-	4.0
F	-	4.2
G	-	4.4
H	-	4.6
I	-	4.8
J	-	5.00

The vernier calibration control (CAL) is provided to adjust the full load current reference level I_n in between the TAP ADJUST range settings.

Alarm and Pickup

The I_2 output of the filter network is applied to the alarm and trip level detector circuits. The alarm circuit pickup adjustment is settable from 0.01 to 0.50 which represents the ratio of magnitude of the negative sequence current to the full load current rating of the machine. The alarm circuit compares the level of I_2 from the filter network to the selected ALARM pickup setting. When I_2 is greater than or equal to the setting and exists for three seconds (a fixed three second time delay), the alarm output contact closes. The alarm setting is usually set lower than the trip level to warn the station operator that corrective action is required.

After pickup ($I_2 \text{ pu} \geq I_{2\div I_n}$), the trip level detector circuit applies the sensed negative sequence current I_2 pu to the minimum and maximum trip timers and the network which integrates the value $(I_2)^2 dt$ equal to the machine constant K. The minimum trip time circuitry, after a 0.2 second time delay, applies a signal to initiate the operation of the oscillograph (optional). The maximum trip time circuitry maintains the same I_2 pu and triggers the output trip contact when the time delay expires. The setting of the maximum trip time setting is based upon the maximum time allowed for a particular K constant. For a conventionally cooled synchronous generator, the permissible $(I_2)^2$ rating is 30 (reference C37.102-1987). Therefore, a setting of 0.35 pu would allow the generator to carry a negative sequence current condition for 245 seconds without damage. For I_2 currents of less than 0.35 pu, the generator will be adequately protected.

When the value of I_2 pu applied to the microprocessor integrator network falls below the pickup setting, the integration will cease and reset at a linear rate of 2.5 seconds per percent of full scale trip time. This linear reset approximates generator cooling.

K Setting

The K setpoint should be set so that the $(I_2 t)$ characteristic of the relay matches the permissible heating characteristic of the generator.

MAX TIME

The maximum timer function prevents negative sequence current from being above pickup for long periods of time. The maximum timer is ORed with the inverse timer such that if either time out occurs, the unit trips.

CALCULATION EXAMPLE

Assume the generator to be protected is rated:

5 Amp CT

15 MVA
13.8 kV
CT Ratio 800/5 A

1 Amp CT

15 MVA
13.8 kV
CT Ratio 800/1 A

The calculated full load current would be:

5 Amp CT

$$I_{full\ load} = \frac{15\ MVA \times 1000}{\sqrt{3} (13.8\ (KV))} = 627.55\ A$$

1 Amp CT

$$I_{full\ load} = \frac{15\ MVA \times 1000}{\sqrt{3} (13.8\ (KV))} = 627.55\ A$$

The current being applied to the relay would be:

5 Amp CT

$$I_{secondary} = 627.56 \times \frac{5}{800} = 3.92\ A$$

1 Amp CT

$$I_{secondary} = 627.56 \times \frac{1}{800} = 0.784\ A$$

The relay TAP ADJUST should be set for this value of full load current.

SETTING TAP ADJUST

Two methods for setting the TAP ADJUST are the single-phase and three-phase methods. In each of these methods, the amount of negative sequence current at which the relay is to trip must be calculated and then applied to the relay. The TAP ADJUST CAL control is then adjusted so that the PICKUP LED lights at that amount of negative sequence current.

Method 1, Single-Phase

If a single-phase quantity is to be applied to the relay, the following equations need to be developed and used in the calculations.

$$I_2 = \frac{1}{3} (I_A + \alpha^2 I_B + \alpha I_C)$$

$$\text{if, } I_B = I_C = 0$$

$$\text{then, } I_2 = \frac{I_A}{3} = \frac{I_{single-phase}}{3}$$

$$\therefore I_2\ pu = \frac{I_2}{I_{nominal}} = \frac{1}{3} \left(\frac{I_{single-phase}}{I_{nominal}} \right)$$

Solving for $I_{nominal}$

Equation A is:

$$I_{nominal} = \frac{1}{3} \left(\frac{I_{single-phase}}{I_2\ pu} \right)$$

Solving for $I_{single-phase}$

Equation B is:

$$I_{single-phase} = 3(I_{nominal})(I_2\ pu)$$

To set the nominal current value (current being applied to the relay as derived in the calculation example), perform the following steps.

- Step 1.** Set the TAP ADJUST switch to the next higher current value (4.0 A, position E for 5 A CT or 0.80 A, position E for 1 A CT) of the desired current value (3.92 A for 5 A CT or 0.784 A for 1 A CT).

NOTE

For the following step, any % value can be used. In this example, 50% has been chosen only for convenience.

- Step 2.** Set the % I_2 PICKUP thumbwheel switch to a value of 50 (0.5 pu).

- Step 3.** Using equation B, solve for $I_{single-phase}$.

Equation B is:

$$\begin{aligned}
 I_{single-phase} &= 3(I_{nominal})(I_2 \text{ pu}) \\
 I_{single-phase} &= 3(3.92)(0.5) \\
 I_{single-phase} &= 5.88 \text{ A}
 \end{aligned}$$

$$\begin{aligned}
 I_{single-phase} &= 3(I_{nominal})(I_2 \text{ pu}) \\
 I_{single-phase} &= 3(0.784)(0.5) \\
 I_{single-phase} &= 1.176 \text{ A}
 \end{aligned}$$

- Step 4.** Apply the calculated $I_{single-phase}$ to one of the phase inputs of the relay (example, phase A input, relay case terminals 8, 9) and adjust the TAP CAL control from a fully clockwise position, counter-clockwise until the front-panel PICKUP LED is ON.

The nominal current value is now set at 3.92 amperes (for 5 A CT) or 0.784 amperes (for 1 A CT) for this application.

Method 2, Three-Phase

If any two phases of a balanced three phase source are rotated, $I_{input} = I_2$ because a reverse phase quantity is being applied. The relay sees this as a 100% negative sequence condition.

To set the nominal current value (current being applied to the relay as derived in the calculation example):

- Step 1.** Set the TAP ADJUST switch to the next higher current value (4.0 amperes, position E for 5 A CT or 0.80 amperes, position E for 1 A CT) of the desired current value (3.92 amperes for 5 A CT or 0.784 amperes for 1 A CT).

NOTE

For the following step, any % value can be used. In this example, 50% has been chosen only for convenience.

- Step 2.** Set the % I_2 PICKUP thumbwheel switch to a value of 50 (0.5 pu)

- Step 3.** If applying A-C-B sequence,

5 Amp CT

1 Amp CT

$$\begin{aligned}
 |I_2| &= |I_A| = |I_B| = |I_C| \\
 \text{then, } 0.5 \times |I_2| &= 0.5 \times |I_{INPUT}| \\
 \therefore 0.5 \times 3.92 &= 1.96 \text{ A}
 \end{aligned}$$

$$\begin{aligned}
 |I_2| &= |I_A| = |I_B| = |I_C| \\
 \text{then, } 0.5 \times |I_2| &= 0.5 \times |I_{INPUT}| \\
 \therefore 0.5 \times 0.784 &= 0.392 \text{ A}
 \end{aligned}$$

- Step 4.** Apply 1.96 amperes (for 5 A CT) or 0.392 amperes (for 1 A CT), and adjust the TAP CAL control from a fully clockwise position, counter-clockwise until the front-panel PICKUP LED is ON.

The nominal current value is now set at 3.92 amperes (for 5 A CT) or 0.784 amperes (for 1 A CT) for this application.

FURTHER CONSIDERATIONS (FOR 5 AMP CT)

Relay Pickup should be based on series unbalances, particularly an open phase, rather than on unbalanced faults. The limiting case for pick-up settings may be an open beyond the generator leads where the negative-sequence current is distributed among several generators. This is in contrast to an open pole on the generator breaker, where the total negative sequence current resulting from the open flows in the generator being protected.

Ref. 1 specifies the continuous negative sequence current limit in per unit after 120 seconds as:

Salient Pole	With connected dampers	0.10
	With unconnected dampers	0.05
Cylindrical Rotor	Indirectly cooled	0.10
	Directly cooled to 960 MV A	0.08
	961 to 1200 MV A	0.06
	1201 to 1500 MV A	0.05

Assume an indirectly cooled cylindrical rotor generator and set PICKUP (trip unit) at 0.06 or 6%. Set alarm pickup below the PICKUP value (trip unit), but above maximum expected unbalance due to untransposed lines, etc. : at 4%. Assume that the manufacturer or the ANSI standard has specified a K factor of 30. Set K = 30.

The maximum negative-sequence current I_2 for an open phase occurs when the open is in the generator leads whether at the generator voltage or on the high side of the unit transformer. Current I_2 for this case can be approximated:

Equation C is:

$$I_2 = I_1 \left(\frac{X_0}{X_2 + X_0} \right)$$

where:

X_2 = negative-sequence reactance of an entire system, including the generator

X_0 = zero-sequence reactance of system connected to an open phase

I_1 = positive sequence current

Assume that $X_0 = 1.6$ times X_2 and $I_1 = 1.0$ p.u. Then, from Equation C:

$$I_2 = \frac{1.0 \times 1.6}{1.0 + 1.6} = 0.62 \text{ p.u.}$$

Then, 0.62 p.u. is approximately the maximum expected current for an open phase for this case. At this level, the inverse delay based on $I_2^2 t = K = 30$ will be:

$$\frac{30}{(0.62)^2} = 78 \text{ sec.}$$

The operator will probably not react fast enough in reducing loading to prevent tripping with a 78 second relay delay. However, at lower levels the alarm unit may provide sufficient advanced warning to allow effective operator corrective action. Accordingly, the MAX TIME setting should permit such possible action. Set MAX TIME at 500 seconds (8.3 minutes).

Reference 1. IEEE Committee Report, *A Standard for Generator Continuous Unbalanced Current Capability*, IEEE Transactions, PAS 92, No. 5, Sept./Oct. 1973, pp 1547-49.

FURTHER CONSIDERATIONS (FOR 1 AMP CT)

To determine the negative sequence current pickup setting, calculate the sensitivity required to insure relay operation at the expected minimum load condition with one pole of the generator breaker open. Assume the value of negative sequence current under this condition is 0.14 A (secondary) or 0.18 per unit. then for our example, the relay must be at least this sensitive. This value must be considered as the upper limit for the pickup setting. A lower setting is recommended. For this example, a value of 12 percent (0.12 per unit) will be used. Set the PICKUP thumbwheel to this value.

To set the value for the ALARM level of negative sequence current, it is only necessary to determine the level that will give an operator sufficient time to attempt to correct the condition. A value of 08 may be set on the thumbwheel.

The K value for this example has been provided by the generator manufacturer. Set this value (25) on the K SET thumbwheel.

The MAX TIME thumbwheel establishes the maximum time allowed for the negative sequence current tripping condition (defined by the PICKUP setting) to persist. If it is determined that this value is 500 seconds, set the thumbwheel at 50.

Since $(I_2)^2 t = K$ establishes the limit of operation, $t = 25$ divided by $0.12^2 = 1736$ seconds.

store.ips.us

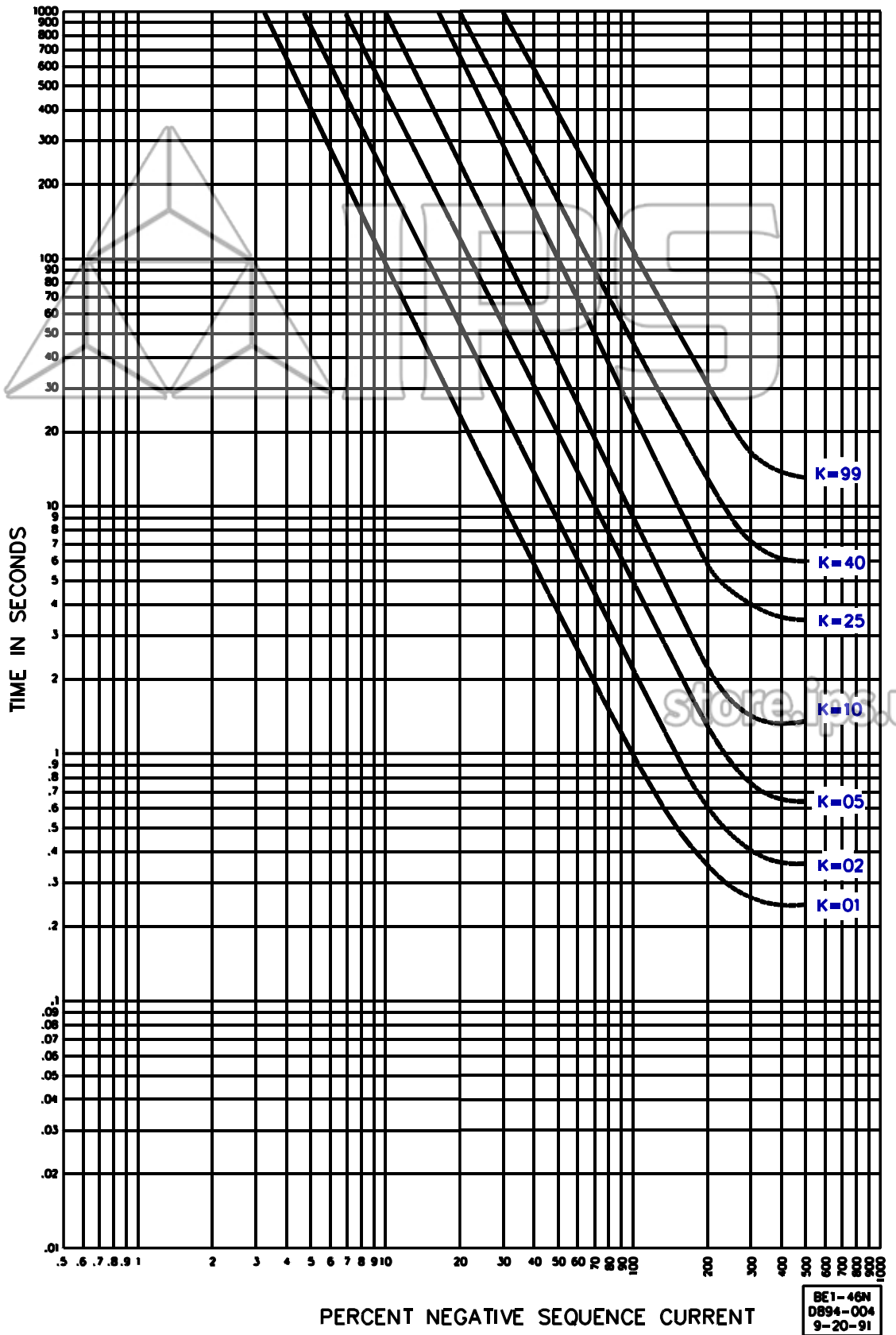

Figure 3-2. Characteristic Curves

SECTION 4 • INSTALLATION

GENERAL

When not shipped as part of a control or switchgear panel, BE1-46N Negative Sequence Overcurrent relays are shipped in sturdy cartons to prevent damage during transit. Immediately upon receipt of a relay, check the model and style number against the requisition and packing list to see that they agree. Visually inspect the relay for damage that may have occurred during shipment. If there is evidence of damage, immediately file a claim with the carrier and notify the Regional Sales Office, or contact the Sales Representative at Basler Electric, Highland, Illinois.

In the event the relay is not to be installed immediately, store the relay in its original shipping carton in a moisture and dust free environment. When the relay is to be placed in service, it is recommended that the operational test procedure (Section 5) be performed prior to installation.

RELAY OPERATING PRECAUTIONS

Before installation or operation of the relay, note the following precautions:

1. A minimum of 0.2 A in the output circuit is required to ensure operation of current operated targets.
2. The relay is a solid-state device. If a wiring insulation test is required, remove the connecting plugs and withdraw the cradle from its case.
3. When the connecting plugs are removed the relay is disconnected from the operating circuit and will not provide system protection. Always be sure that external operating (monitored) conditions are stable before removing a relay for inspection, test, or service.
4. Be sure the relay case is hard wired to earth ground using the ground terminal on the rear of the unit. It is recommended to use a separate ground lead to the ground bus for each relay.

DIELECTRIC TEST

In accordance with ANSI/IEEE C37.90-1978, one-minute dielectric tests (high potential) may be performed as follows:

All circuits to ground:	2121 Vdc.
Input to output circuits:	1500 Vac or 2121 Vdc.

MOUNTING

Because the relay is of solid state design, it does not have to be mounted vertically. Any convenient mounting angle may be chosen. Relay outline dimensions and panel drilling diagrams are shown in Figures 4-1 through 4-6.

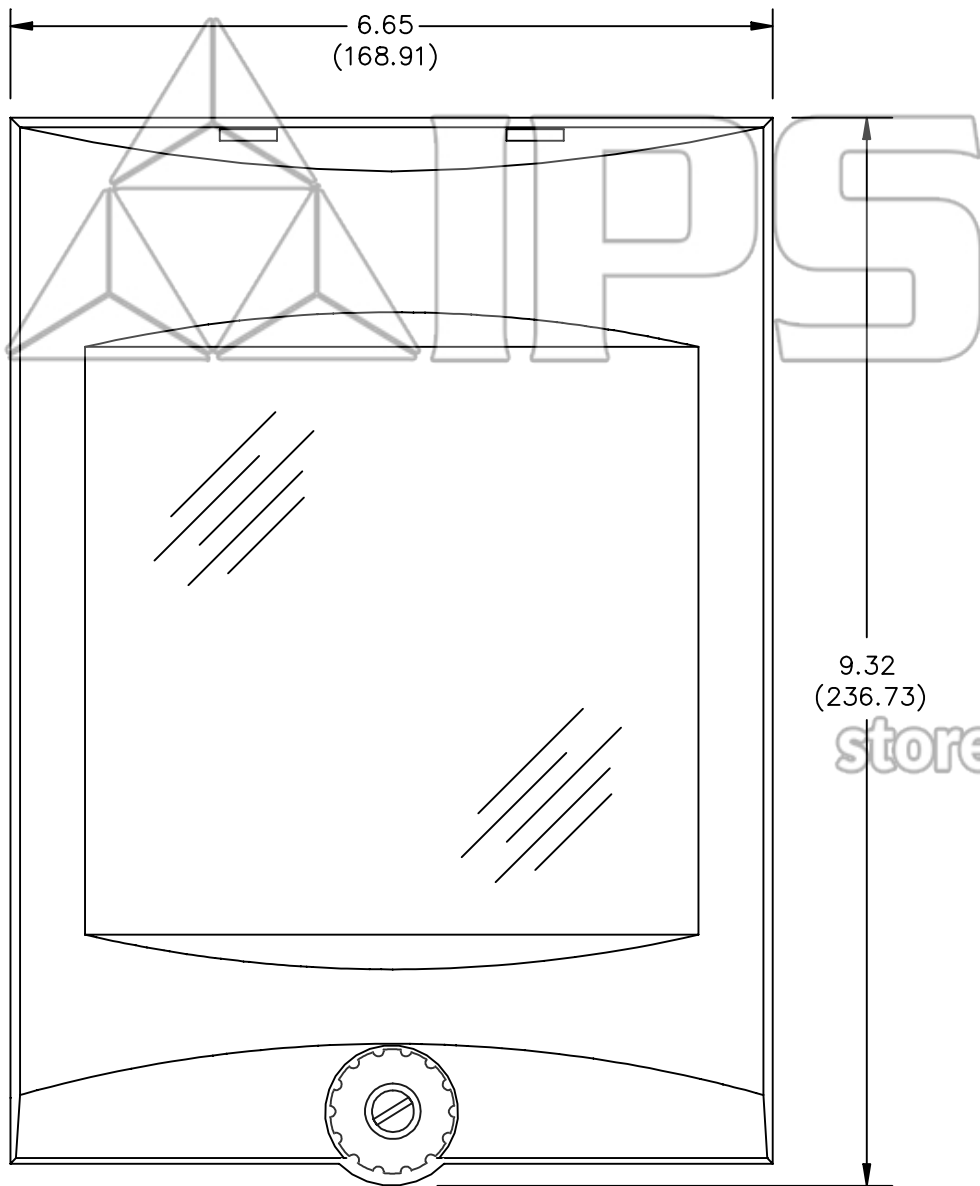

D1427-01
2-02-01

Figure 4-1. S1 Case, Outline Dimensions, Front View

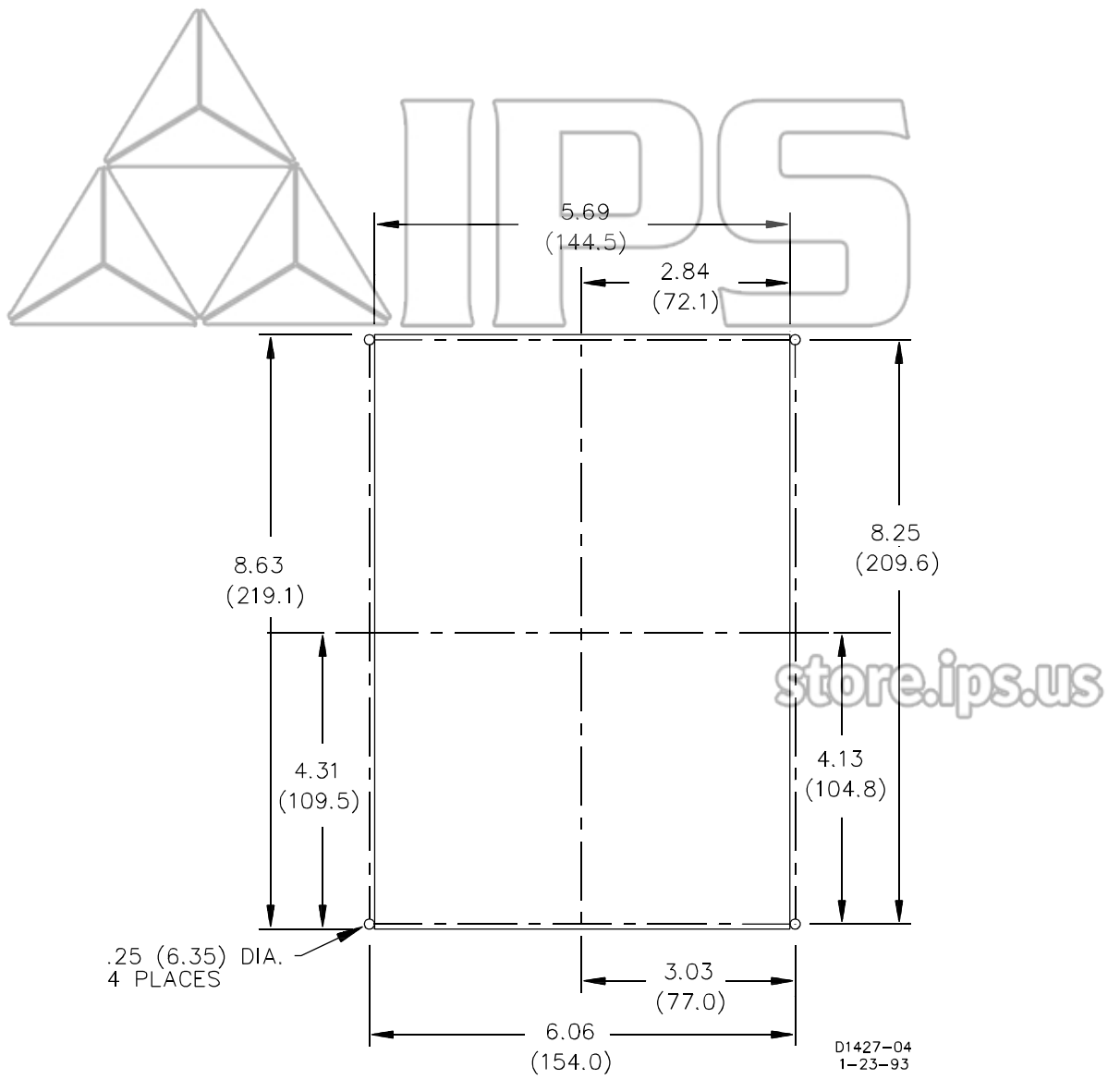

Figure 4-2. S1 Case, Panel Drilling Diagram, Semi-Flush Mounting

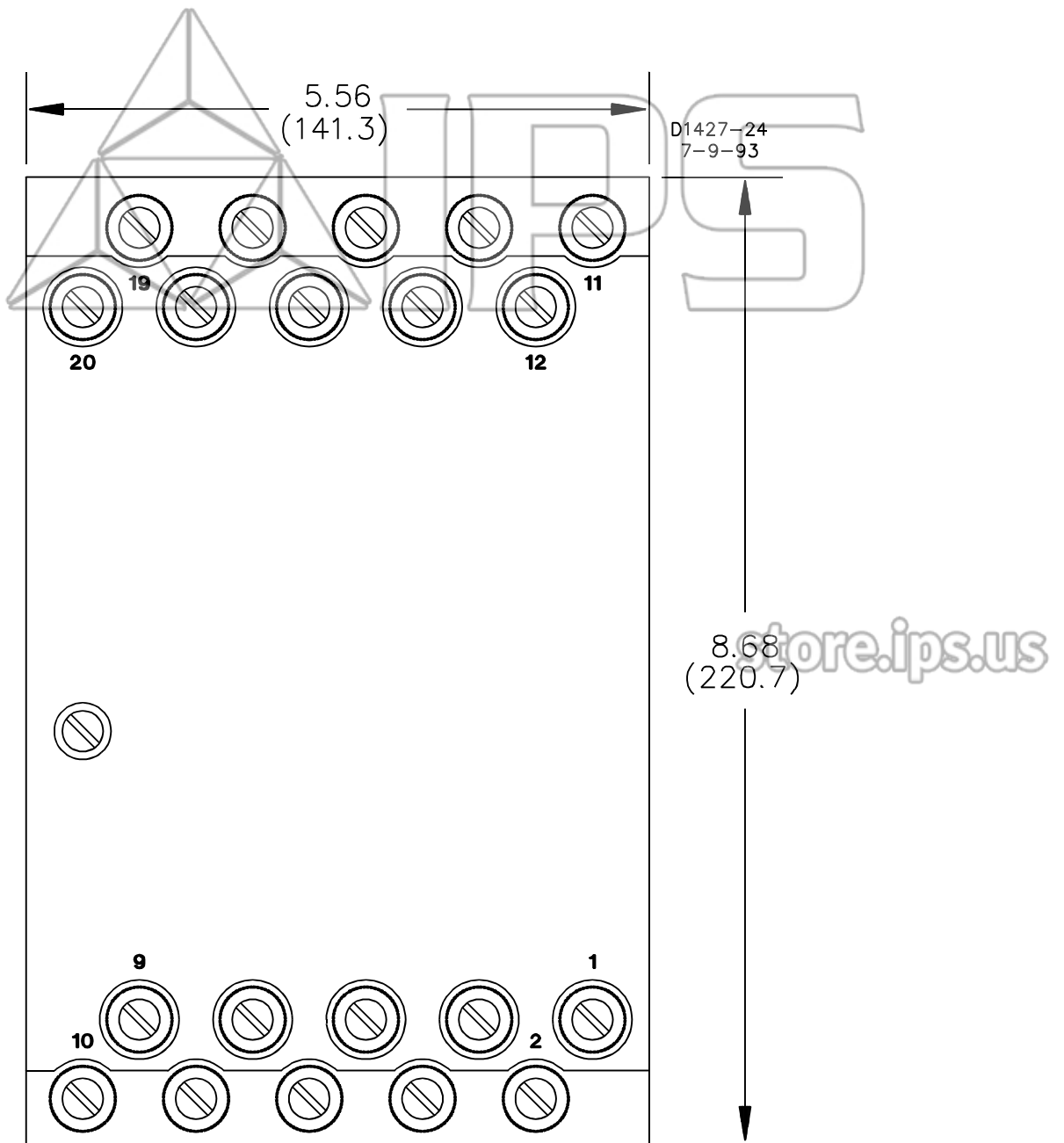

Figure 4-3. S1 Case, Double-Ended, Semi-Flush Mounting, Outline Dimensions, Rear View

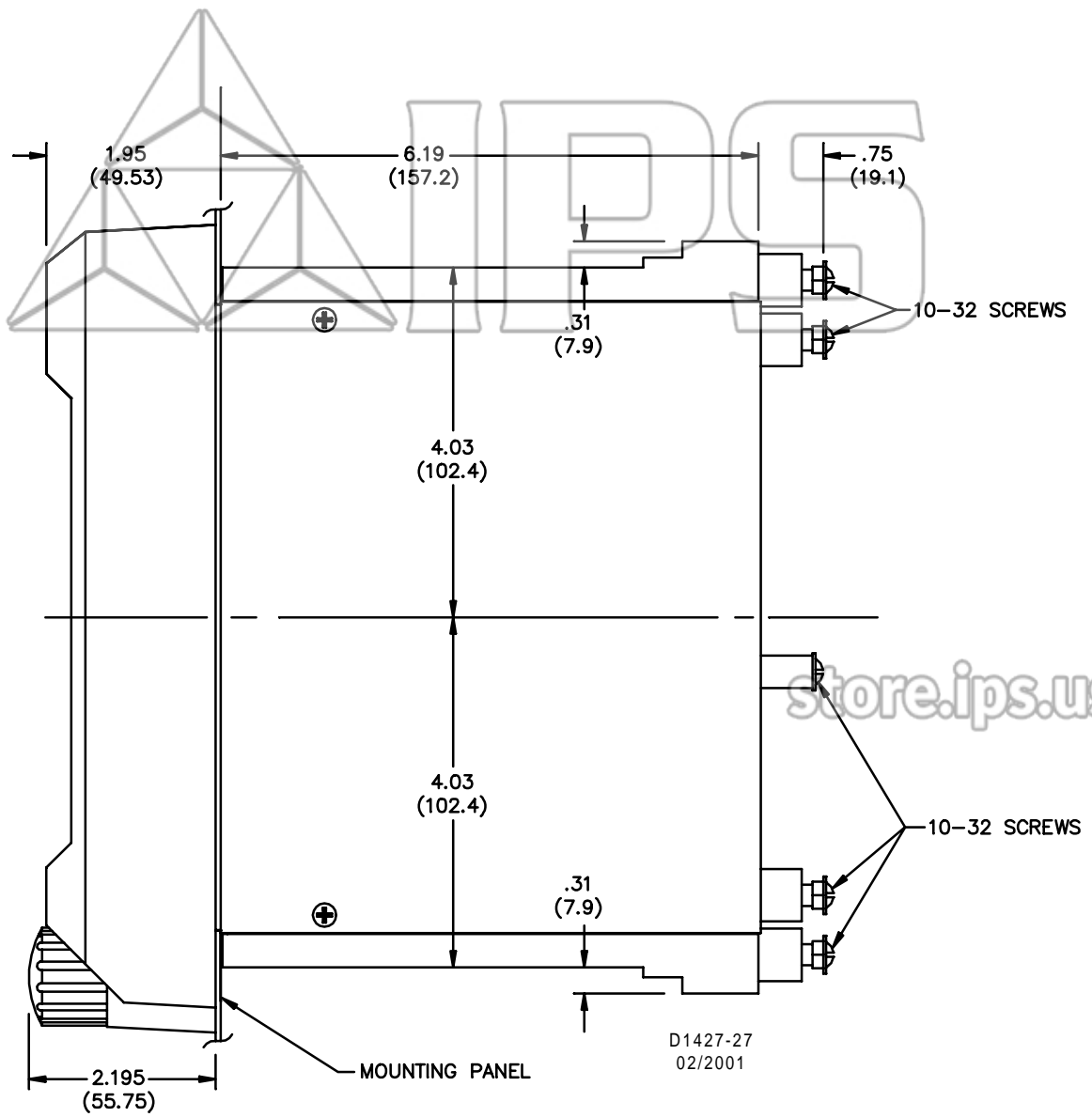

Figure 4-4. S1 Case, Double-Ended, Semi-Flush Mounting, Side View

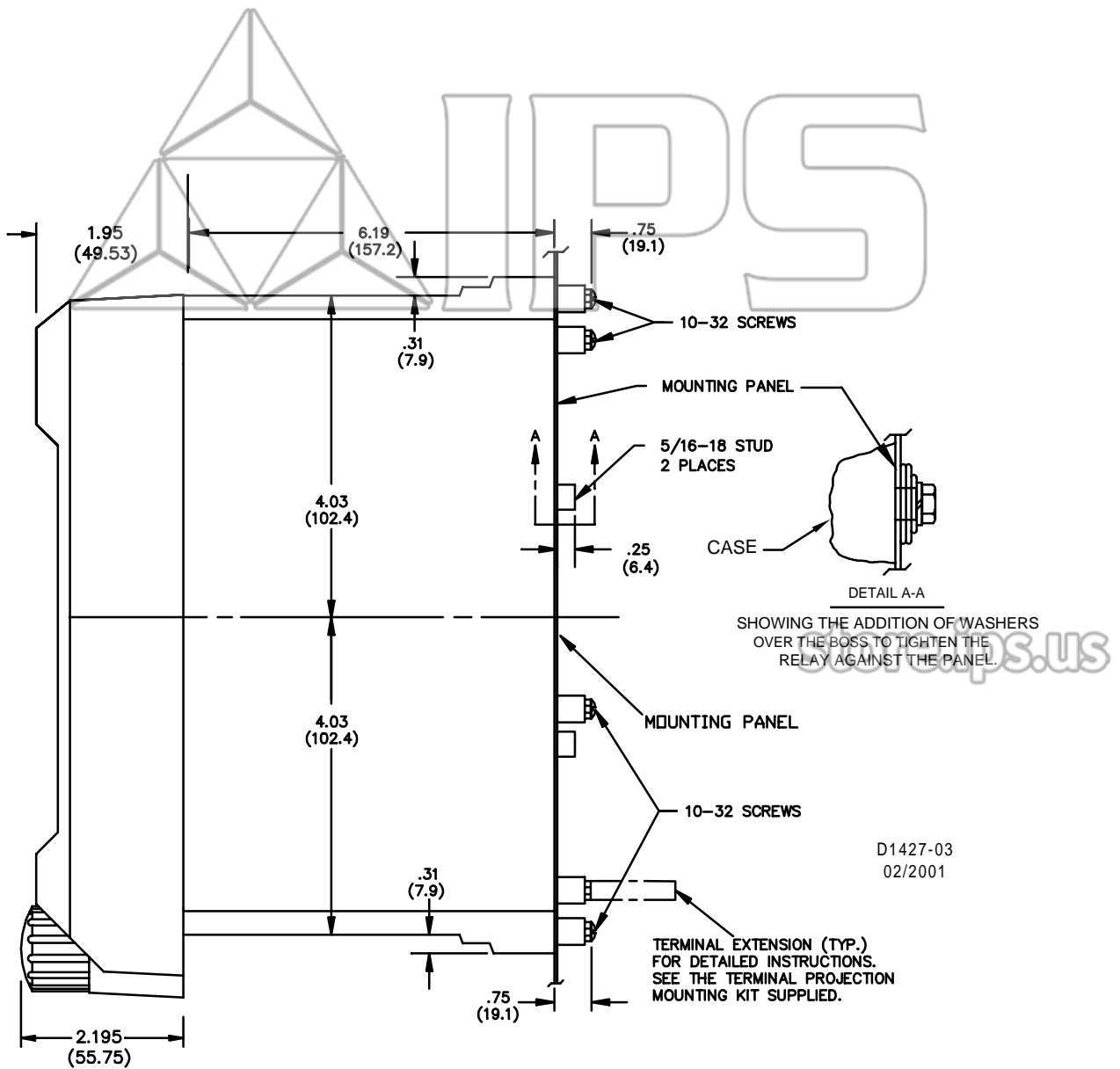

Figure 4-6. S1 Case, Double-Ended, Projection Mounting, Side View

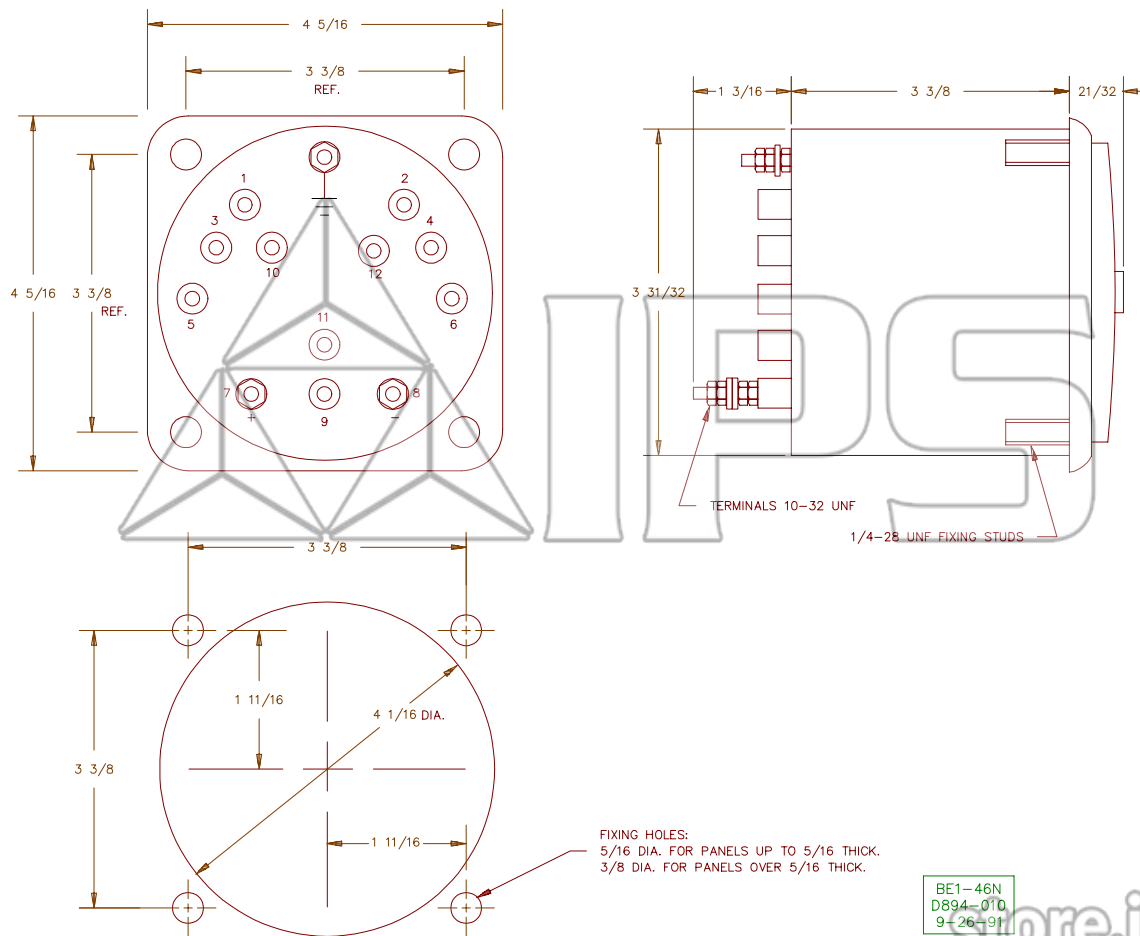

Figure 4-7. Remote Meter Dimensions and Drilling Diagram

CONNECTIONS

Incorrect wiring may result in damage to the relay. Be sure to check model and style number against the options listed in the Style Number Identification Chart before connecting and energizing a particular relay.

NOTE

Be sure the relay case is hard-wired to earth ground with no smaller than 12 AWG copper wire attached to the ground terminal on the rear of the relay case. When the relay is configured in a system with other protective devices, it is recommended to use a separate lead to the ground bus from each relay.

Except as noted previously, connections should be made with minimum wire size of 14 AWG. Typical dc control connections are shown in Figure 4-8. Typical ac sensing connections are shown in Figure 4-9. Typical internal connections are shown in Figure 4-10.

Relays that operate using phase currents to determine the negative sequence component are sensitive to phase rotation. BE1-46N Negative Sequence Overcurrent Relays are phase rotation sensitive. All connections shown in this manual assume ABC rotation.

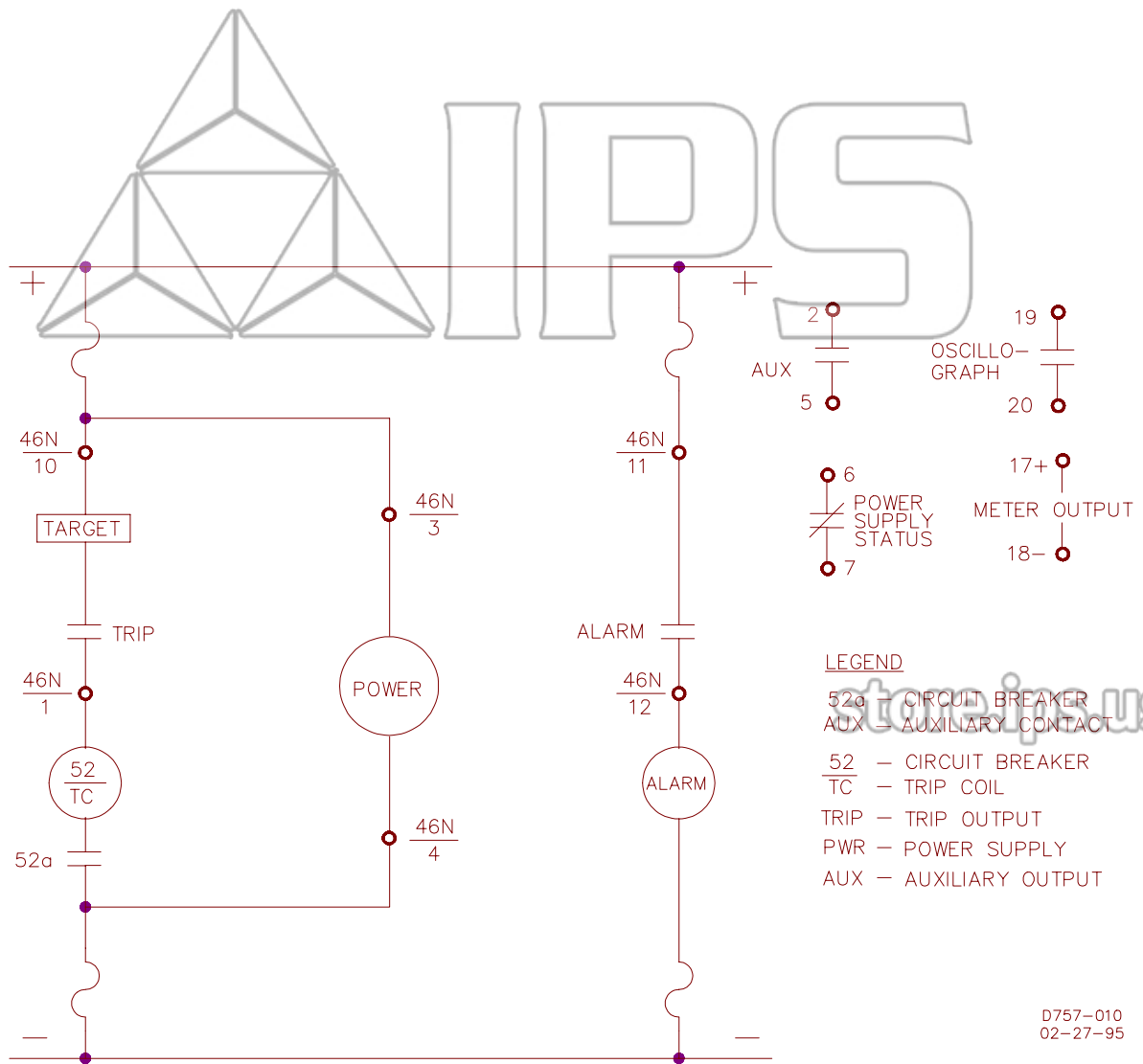

Figure 4-8. Typical DC Control Connections

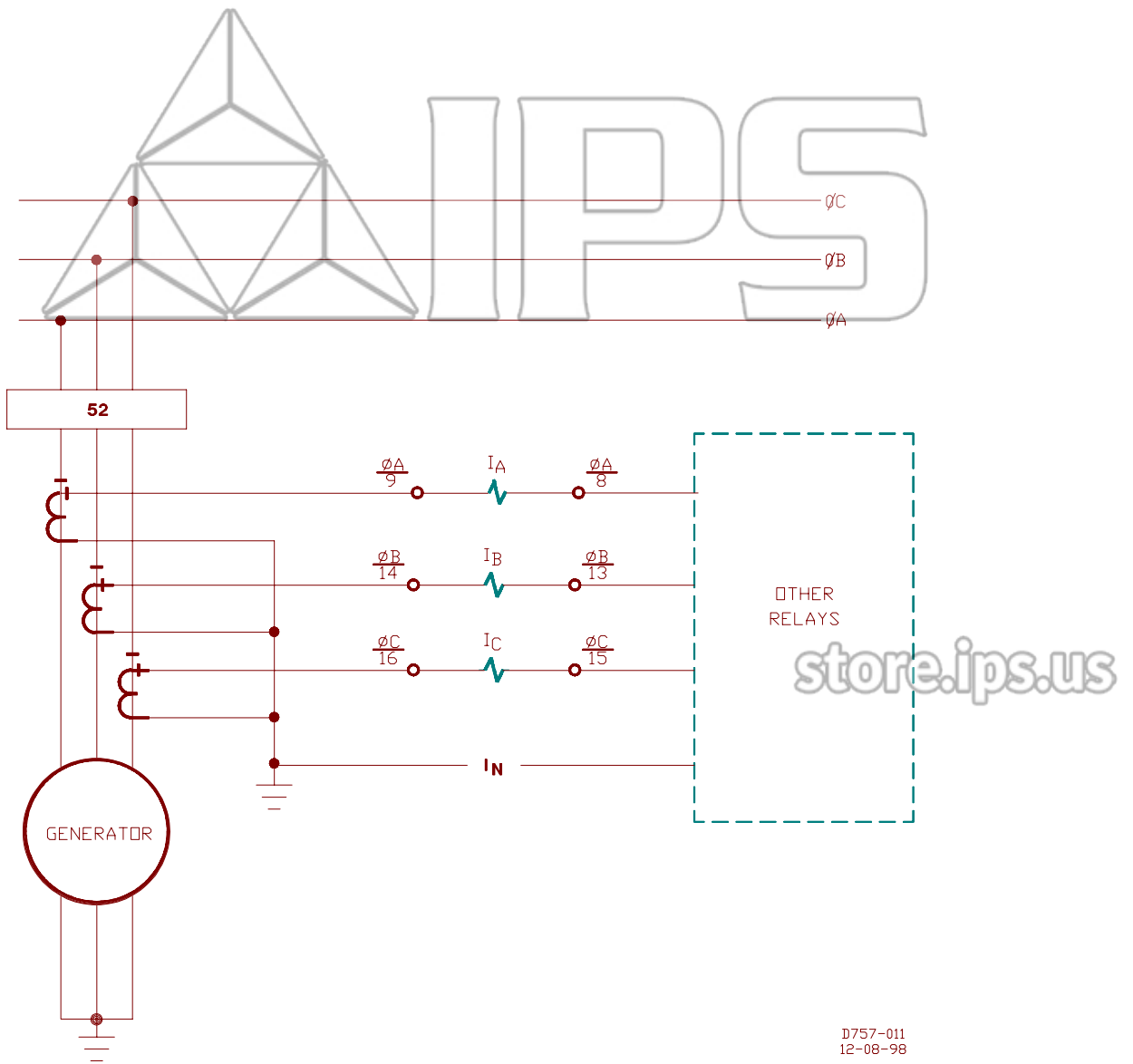

Figure 4-9. Typical AC Sensing Connections

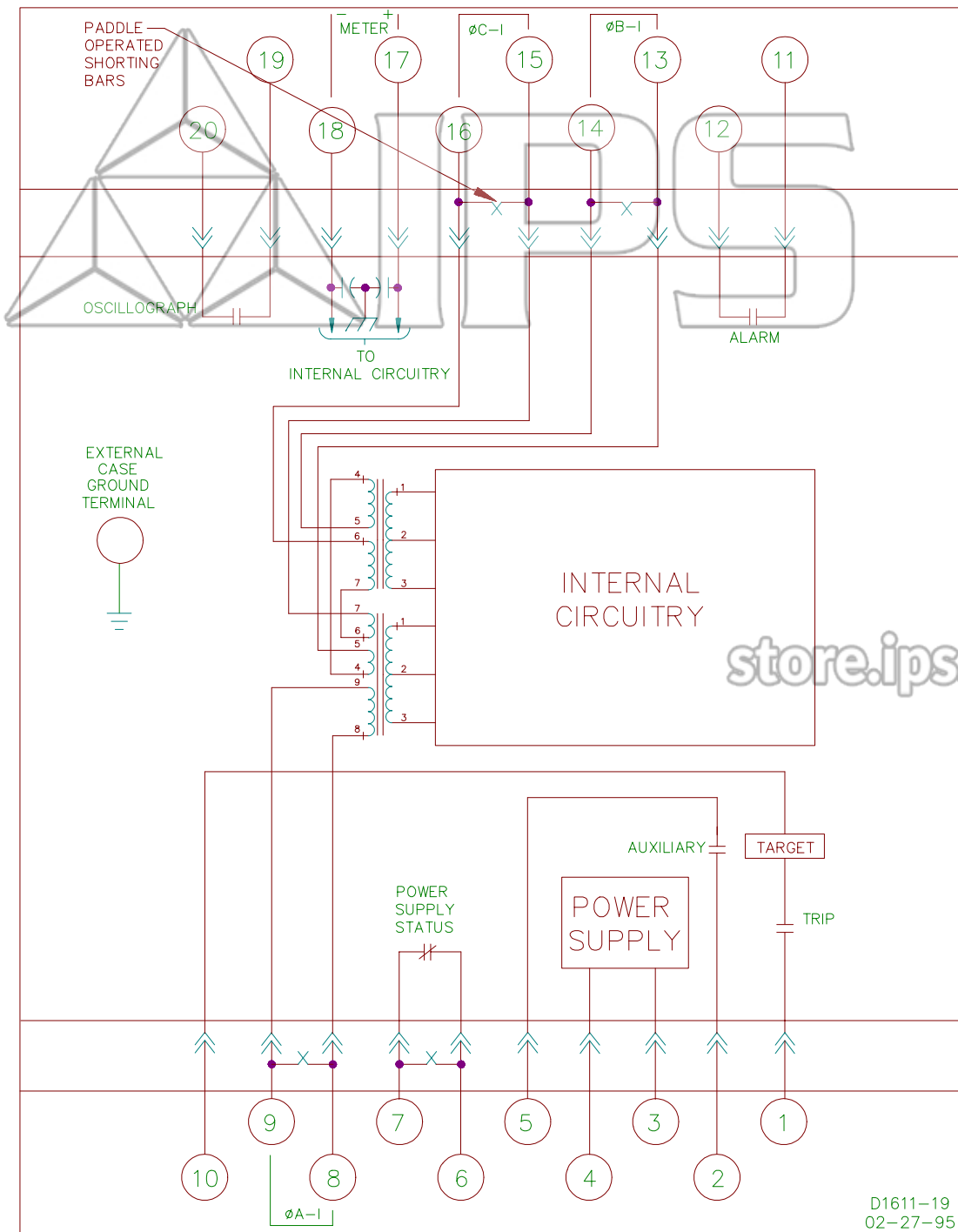

Figure 4-10. Typical Internal Connections

SECTION 5 • TESTING

GENERAL

Although the BE1-46N is designed to monitor three-phase currents, verification of the relay pickup and dropout can be accomplished by using a single-phase source. To verify all three phases using a single-phase current source, repeat the operational test procedure for each of the three phases.

TESTING

The test is divided into three different functional areas. The functional areas are:

- Pickup and alarm
- Timing
- Max time

OPERATIONAL TEST PROCEDURE

Pickup and Alarm

Additional testing to verify trip and alarm circuit pickup and dropout may be implemented by changing the PICKUP and ALARM thumbwheel settings. The procedures remain the same but the values differ. To determine the correct values, the following formula and derivatives are given.

$$I_N = \text{TAP ADJUST value}$$

$$I_2 \text{ pu} = \frac{I_2}{I_N}$$

store.ips.us

$$\text{also, } \% I_2 = (I_2 \text{ pu}) (100 \%)$$

Equation A

$$\text{Negative Sequence } I = I_2 = \frac{1}{3} (I_A + \alpha^2 I_B + \alpha I_C)$$

$$I_2 \text{ pu} = \frac{I_2}{I_N} = \frac{1}{3(I_N)} (I_A + \alpha^2 I_B + \alpha I_C)$$

If testing single phase ($I_B = 0$, and $I_C = 0$) then:

$$I_2 \text{ pu} = \frac{1}{3(I_N)} (I_A + \alpha^2 I_B + \alpha I_C)$$

Equation B

$$I_2 \text{ pu} = \frac{1}{3(I_N)} (I_A)$$

Please note that the results obtained from these procedures may not fall within specified tolerances. When evaluating results, consideration must be given to three important factors.

1. The inconsistent method of testing. (Example: The start pulse to the timer does not always begin on the zero crossing.)
2. The inherent error of the test equipment used. Test equipment should be accurate to within 1.0% or better.
3. The tolerance level of components used in the test setup. Components should be specified to within 1.0% or better.

Step 1. Set the TAP ADJUST to the A position and turn the CAL control fully CW (5 A CT = 3.2 A) (1 A CT = 0.64 A).

Step 2. Set the PICKUP and ALARM thumbwheel switches to 33 (33%).

Step 3. Connect a current source to the phase A input terminals.

NOTE

Time delay for the ALARM trip circuit is factory set at 3.0 seconds \pm 5%. Three seconds after the ALARM LED lights, the ALARM output contacts actuate.

Step 4. Slowly increase the magnitude of the phase A current until the ALARM and PICKUP LEDs just light. Do not increase the current any further.

Step 5. Measure and record the applied current and observe the remote meter.

RESULT: The recorded pickup value should be 3.168 A \pm 0.048 A for 5 A CTs and 0.634 A \pm 0.048 A for 1 A CTs, and the meter should correspond to 33%.

Step 6. Slowly decrease the input current until the PICKUP and ALARM LED's go out.

Step 7. Measure and record the applied current and observe the remote meter.

RESULT: The recorded value for dropout should be no less than 98% of the pickup level or 0.064 A (for a 5 A CT) or 0.12 (for a 1 A CT) less than that recorded for PICKUP and the meter should correspond.

Timing

The results obtained from these procedures are sufficient to determine the relay timing characteristics.

Step 1. Connect the test circuit as shown in the test setup diagram, Figure 5-1, set TAP ADJUST to A position, and the CAL control fully CW.

Step 2. Adjust current source to apply 4.8 A for the 5 A CT or .96 A for the 1 A CT (50% I_2 or 0.5 pu) to the phase A input and set the front panel controls as follows:

- PICKUP and ALARM to 05
- K SET to 10
- MAX TIME to 10

NOTE

Three seconds after the closing of switch A the ALARM input contacts actuate. (Time delay is factory set at 3 seconds.)

Step 3. Close switch A to apply current to relay and initiate timer.

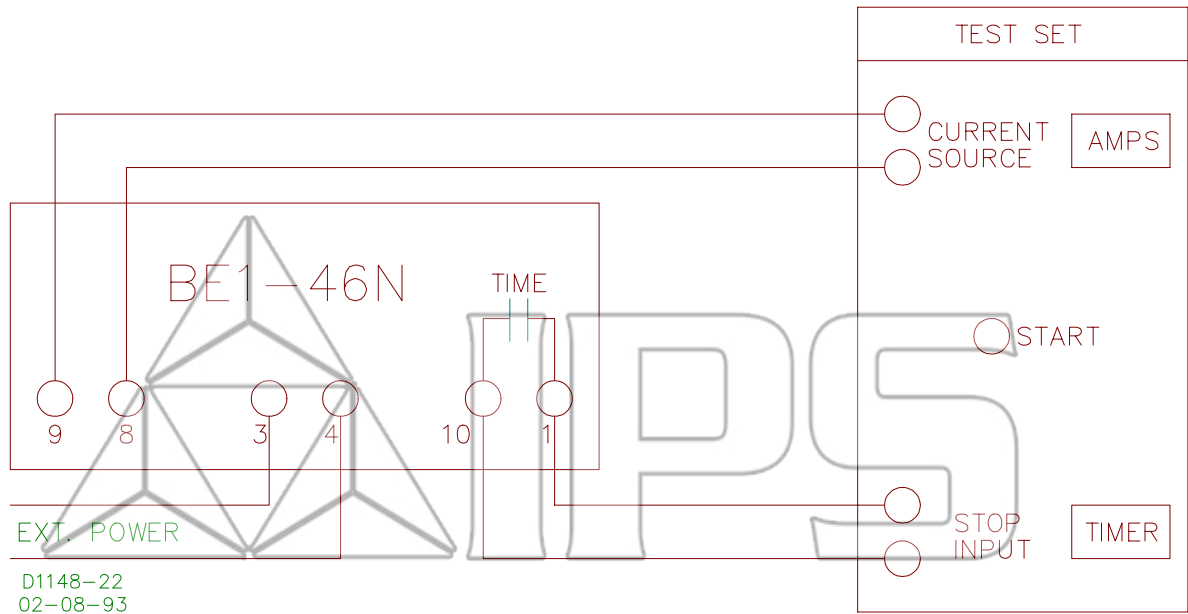

Figure 5-1. Test Setup Diagram

Step 4. Observe timer reading after PICKUP LED lights.

RESULT: Timer should indicate 40 ±2 seconds.

NOTE

Relay power must be cycled OFF and ON between each timing test to ensure that the reset time has been defeated.

Step 5. To calculate the time required for the timing function, use the following formula:

$$t = \frac{K}{(I_2 \text{ pu})^2}$$

Substituting in the formula:

$$t = \frac{10}{(0.5)^2} = 40 \text{ seconds}$$

MAX TIME

The following procedure will show how the MAX Time affects relay timing.

Step 1. Connect the test circuit shown in the test setup diagram, Figure 5-1, set the TAP ADJUST switch to A position, and CAL control fully CW.

Step 2. Adjust current source to apply 2.4 A (25% I₂ or 0.25 pu) to the phase A input and set the front panel controls as follows:

- PICKUP and ALARM to 05.
- K-SET to 10.
- MAX TIME to 10.

Step 3. Close switch A to apply current to relay and initiate timer.

Step 4. Observe timer reading after PICKUP LED lights.

RESULT: Timer should indicate 100 ±5 seconds.

Step 5. To calculate the time required for the timing function, use the following formula:

$$t = \frac{K}{(I_2 \text{ pu})^2} = \frac{10}{(0.25)^2} = 160$$

We find t = 160 seconds. But, because the MAX TIME was set for 10 (100 seconds), trip occurred at 100 seconds.

This concludes the operational test. To test all three phase inputs, repeat the test procedures applying the single-phase current source input to phase B inputs and then phase C inputs.

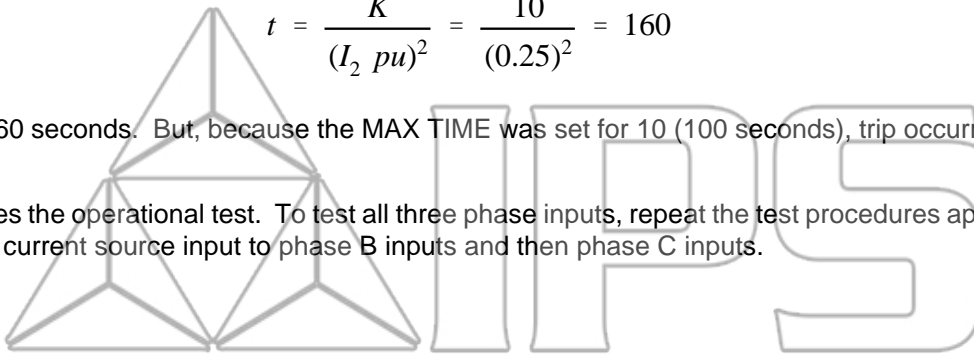

store.ips.us

SECTION 6 • MAINTENANCE

GENERAL

BE1-46N Negative Sequence Overcurrent Relays require no preventive maintenance other than a periodic operational test (refer to Section 5 for operational test procedures). If factory repair is desired, contact the Customer Service Department of the Power Systems Group, Basler Electric, for a return authorization number prior to shipping.

IN-HOUSE REPAIR

In-house replacement of individual components may be difficult and should not be attempted unless appropriate equipment and qualified personnel are available.

CAUTION

Substitution of printed circuit boards or individual components does not necessarily mean the relay will operate properly. Always test the relay before placing it in operation.

Where special components are involved, Basler Electric part numbers may be obtained from the number stamped on the component or assembly, the schematic, or parts list. These parts may be ordered directly from Basler Electric. When complete boards or assemblies are needed, the following information is required.

1. Relay model and style number
2. Relay serial number
3. Board or assembly
 - a) Part number
 - b) Serial number
 - c) Revision letter
4. The name of the board or assembly.

store.ips.us

STORAGE

This protective relay contains aluminum electrolytic capacitors which generally have a life expectancy in excess of 10 years at storage temperatures less than 40°C. Typically, the life expectancy of the capacitor is cut in half for every 10°C rise in temperature. Storage life can be extended if, at one-year intervals, power is applied to the relay for a period of thirty minutes.

SECTION 7 • MANUAL CHANGE INFORMATION

SUMMARY AND CROSS REFERENCE GUIDE

This section contains information concerning the previous editions of the manual. The substantive changes to date are summarized in the Table 7-1.

Table 7-1. Summary of Changes

Revision	Summary of Changes	ECA(ECO)/Date
A	Changed case terminal polarity for the remote indicator.	7792 / 04-25-86
B	Changed Instructional Manual format and presentation to increase readability and correct minor errors.	12206 / 09-30-91
C	Changed <i>Section 1, Specifications</i> , and <i>Section 4, Installation</i> to reflect ECA changes in the relay. Corrected typographical errors in <i>Section 3</i> . Divided <i>Section 4, Installation</i> into two sections <i>Section 4, Installation</i> and <i>Section 5, Testing</i> .	14961 / 02-28-95
D	Changed all sections to include one ampere sensing input range as standard styles. Changed <i>Section 1, Specifications</i> , and <i>Section 3</i> to reflect the changes in the relay. Changed Figures 4-9 and 4-11 to remove power supply status references. Updated Figures 1-1 and 3-2 to reflect changes made in the relay.	15187 / 08-02-95
E	Deleted all references to Service Manual. Corrected Figure 1-1 "Style Number Identification Chart" Power Supply Type T from "230 Vac" to "240 Vac" and Type S, removed "Switchable." Deleted IEC 255-5 from Isolation Specification and Section 4 under Dielectric Test. Added UL Recognition to Specifications. Added 1 amp CT values to Section 3 for setting considerations. Changed <i>Section 3</i> to include power supply status output. Changed Figures 3-1, 4-9, and 4-11 to reflect this change. Added "Max Time" to Section 3. Timing in Section 5, changed Step 5 from "MAX TIME" to "time required for." Changed the format of the manual and corrected minor errors.	1591 / 11-24-95
F	Updated the drawings in section 4 to reflect the latest S1 Case drawings.	12263/02-09-01