



GENERAL CATALOGUE

Thyristor Power Controllers



Powered by Innovation



Summary

| | |
|---|-----------|
| General features | 2 |
| REVO S | 4 |
| REVO S 1PH | 6 |
| REVO S 2PH | 8 |
| REVO S 3PH | 10 |
| REVO SX | 12 |
| REVEX | 14 |
| REVEX 1PH | 16 |
| REVEX 2PH | 18 |
| REVEX 3PH | 20 |
| REVEX PA..... | 22 |
| REVO C | 24 |
| REVO C 1PH | 26 |
| REVO C 2PH | 28 |
| REVO C 3PH | 30 |
| REVO C Extended Version..... | 32 |
| REVO C Options | 34 |
| CD3000S | 36 |
| CD3000S 1PH | 38 |
| CD3000S 2PH | 40 |
| CD3000S 3PH | 42 |
| REVO PN | 44 |
| REVO PB | 50 |
| REVO PC | 52 |
| Operator panels | 60 |
| Communication modules | 61 |
| Features comparison - Thyristor units SINGLE LOOP | 62 |
| Application guide for thyristor unit selection SINGLE LOOP | 64 |





CD Automation was founded in 1987 in Legnano (MI) and, thanks to its thirty years of experience in the sector, produces thyristor power units for the automation of industrial temperature control. Thanks to a system of subsidiaries and partners of international standing in the industrial temperature control sector, CD Automation supports and develops any customer requirement.

CD Automation's production is characterised by single-phase, two-phase and three-phase models with a current range between 3A and 2700A. Our thyristors, equipped with powerful microprocessors, are designed to meet every market requirement and are configurable so that they can be used in different applications, thus making it possible to always find the most suitable solution.

Through innovation in cabling, fieldbus connectivity and space management within the control panel, it is possible to reduce the footprint and thus save on the entire project.

Our Mission:

Providing innovative solutions to control heating loads of all kinds.

Technical support in design, pre- and after-sales, remote and on-site technical assistance.

Being a leading company in the thyristor unit market both nationally and internationally.



General features

Environmental installation conditions

| | |
|----------------------------|---|
| Ambient temperature | 0÷40°C (32÷104°F) at nominal current. Over 40°C/104°F use the derating curve (max 50°C). |
| Storage temperature | -25°C to 70°C / -13°F to 158°F |
| Installation place | Avoid installing in areas exposed to direct sunlight, conductive dust, corrosive gases, vibrations, water, or salty environments. |
| Altitude | Up to 1000 meter over sea level. For higher altitude reduce the nominal current by 2% for each 100mt over 1000mt (<i>see Derating table</i>). |
| Humidity | From 5 to 95% without condensation and ice. |
| Pollution Level | Up to 2° level ref. IEC 60947-1 6.1.3.2 |

Derating

● Derating curve

The nominal current values specified for the units are based on their operation in continuous service at an ambient temperature of 40°C. To adjust for temperatures above 40°C, multiply the nominal current by the derating coefficient (K) as indicated below.

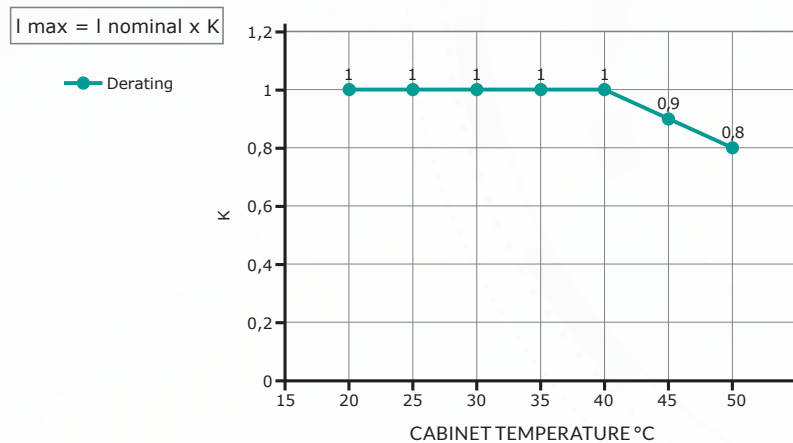

● SCR unit size derating with increasing altitude

When installing our SCR units at altitudes exceeding 1000 metres above sea level, it is advised to adjust the current size using a derating coefficient. This adjustment should take into account the stability of the electrical supply and the operating temperatures within the switch cabinet.

Minimal derating:

The derating of the current size by **-1% per 100m** above 1000m above sea level.

Derating with operating margin (recommended):

The derating of the current size by **-2% per 100m** above 1000m above sea level.

Example: The derating coefficient for an SCR device installed at an altitude of 3500 metres above sea level must be calculated as follows:

$$[(3500-1000)/100]=25\% \text{ minimum}$$

$$[(3500-1000) \times 2/100]=50\% \text{ recommended}$$

Firing types

Zero Crossing (ZC)

ZC firing mode is used with the logic output from a temperature controller and so the thyristor operates like a contactor. The cycle time is performed by the temperature controller. Zero Crossing minimizes interferences as the thyristor unit switches ON-OFF at zero voltage.

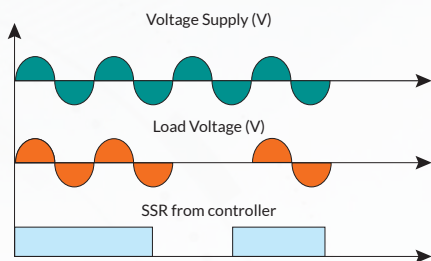

Burst Firing (BF)

This firing is performed digitally within the thyristor unit at zero volts, producing no EMC interference. Analogue input is necessary for BF and the number of complete cycles must be specified for 50% power demand. This value can be between 1 and 255 complete cycles, determining the speed of firing. When 1 is specified, the firing mode becomes Single Cycle (SC).

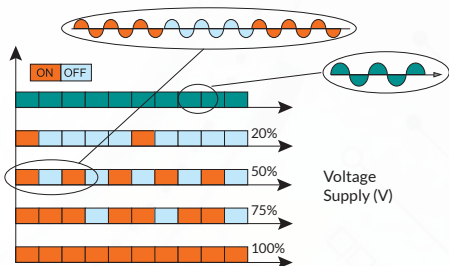

Single Cycle (SC)

SC is the fastest zero crossing switching method. At 50% input signal, one cycle is ON and one cycle is OFF. At 75%, 3 cycles are ON and one cycle is OFF. If power demand is 76% the unit performs the same as for 75% but every time the unit switches ON the microprocessor divides 76/75 and memorises the ratio. When the sum is one the unit delivers one cycle more to the load. With this firing it is necessary to have analogue input.

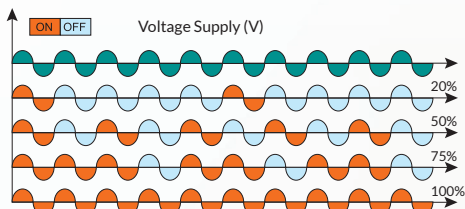

Delayed Triggering (DT)

Used to switch the primary coil of transformers when coupled with normal resistive loads (not cold resistance) on the secondary, DT prevents the inrush current when zero voltage (ON-OFF) is used to switch the primary. The thyristor unit switches OFF when the load voltage is negative and switches ON only when positive with a pre-set delay for the first half cycle.

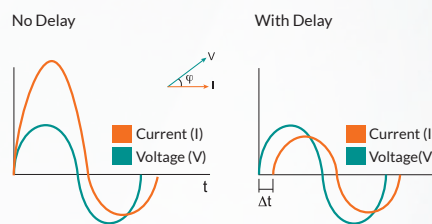

Phase Angle (PA)

PA controls the power to the load by allowing the thyristor to conduct for part of the AC supply cycle only. The more power required, the more the conduction angle is advanced until virtually the whole cycle is conducting for 100% power. The load power can be adjusted from 0 to 100% as a function of the analogue input signal, normally determined by a temperature controller or potentiometer, PA is normally used with inductive loads.

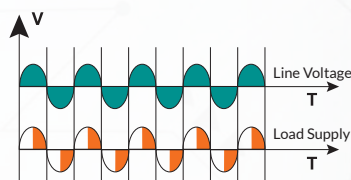

Soft Start + Burst Firing (S+BF)

This is an additional feature to Burst Firing. Starting in Phase Angle mode, the unit ramps from zero to full voltage at a preset time, finishing at full conduction for remainder of the ON period. Ideally used to switch small inductive loads, S+BF avoids current surge and minimizes electrical interference.

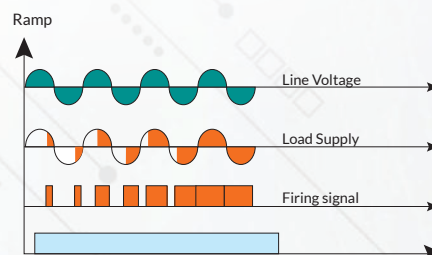

REVO S



Main features

The features of REVO S are suitable for basic applications where communication is not required

- The REVO S family includes 1-2-3 phase units from 30A to 800A
- Nominal voltage 480V, 600V and 690V
- Input: SSR or analog ($4\div 20\text{mA}/0\div 10\text{V}$)
- Firing: Burst Firing (Fast Zero Crossing)
- Heater Break: Alarm to diagnose partial or total break of the load or thyristor short circuit
- Extrarapid fuse with fuse holder up to 40A
- Extrarapid fixed fuses from 60A to 800A
- **100 kA** Short Circuit Current (SCCR) tested
- **CE** and **cUL** approvals

Load type

Resistive / Medium and long-wave infrared lamps

Cannot be used for capacitive loading. For information contact our technical department

Industrial applications

- | | | | |
|---------------------------------|---------------------|---------------------|------------------------|
| ● Petrolchemicals | ● Autoclaves | ● Polysilicon | ● Automobile |
| ● Platform for oil extraction | ● Electric furnaces | ● Chemical | ● Paint drying |
| ● Conventional power generator | ● Galvanic process | ● Plastic machinery | ● UV drying |
| ● Chemicals and pharmaceuticals | ● Glass industry | ● Packing machinery | ● Car internal fitting |

REVO S & SSR - FEATURES

| | Description | Revo S 1PH | | Revo S 2PH | | Revo S 3PH | |
|-----------|--|-----------------|-------------|-----------------|-------------|-----------------|-------------|
| | CODE | RS1 | | RS2 | | RS3 | |
| Load Type | Max voltage 480V | ● | | ● | | ● | |
| | Max voltage 600V | ● | | ● | | ● | |
| | Max voltage 690V | ● ≥60A | | ● ≥60A | | ● ≥60A | |
| | Single phase | ● | | | | | |
| | 3 phase load star no neutral or delta | | | ● | | ● | |
| | 3 phase load star with neutral | | | | | ● | |
| | 3 phase load open delta | | | | | ● | |
| Input | SSR 4:30VDC | ● | | ● | | ● | |
| | 4:20 mA | ○ | | ○ | | ○ | |
| | 0:10 Vdc | ○ | | ○ | | ○ | |
| | Digital potentiometer | ○ | | ○ | | ○ | |
| Firing | Zero crossing | ● | | ● | | ● | |
| | Burst firing 4-8-16 (1) | ○ | | ○ | | ○ | |
| Options | Heater break + thyristor short circuit | ○ | | ○ | | ○ | |
| | Integrated extrarapid fixed fuses | ● >40A | | ● >40A | | ● >40A | |
| | Extrarapid fuse & fuse holder | ○ ≤40A | | ○ ≤40A | | ○ ≤40A | |
| | REVO PC (2) | ○ | | | | | |
| Current | CURRENT | SIZE | | SIZE | | SIZE | |
| | Voltage | 480÷600V | 690V | 480÷600V | 690V | 480÷600V | 690V |
| | 30 | SR3/SR6 | | SR4/SR7 | | SR5/SR8 | |
| | 35 | SR3/SR6 | | SR4/SR7 | | SR5/SR8 | |
| | 40 | SR3/SR6 | | SR4/SR7 | | SR5/SR8 | |
| | 60 | SR12 | S11 | SR15 | S11 | SR16 | S11 |
| | 75 | | | SR15 | | SR16 | |
| | 90 | SR15 | S11 | SR15 | S11 | SR16 | S11 |
| | 120 | SR15 | S11 | SR16 | S13 | SR17 | S13 |
| | 150 | SR15 | S11 | SR16 | S13 | SR17 | S13 |
| | 180 | SR15 | S11 | SR16 | S13 | SR17 | S13 |
| | 210 | SR15 | S11 | SR16 | S13 | SR17 | S13 |
| | 300 | S12 | | S14 | S14 | S14 | S14 |
| | 350 | | | | | S14 | S14 |
| | 400 | S12 | S12 | S14 | S14 | S14 | S14 |
| | 450 | | | S14 | S14 | S14 | S14 |
| | 500 | S12 | S12 | S14 | S14 | S14 | S14 |
| | 600 | S12 | S12 | S14 | S14 | | |
| | 700 | S12 | S12 | S14 | S14 | | |
| | 800 | S15* | S15 | S16* | S16 | S17* | S17 |

● Standard ○ Option ■ CE standard + cUL option (*800A UL only) ■ CE only ■ cUL only

Nota 1: 4-8-16 Cycles Simplified Burst Firing available with Analog Input only

Nota 2: REVO PC is an external unit designed to handle multiple zones, able to minimize energy cost, keep power factor close to 1 and add Field Bus.

REVO S 1PH

Technical Specification

- **Load type:** Normal resistance, infrared long and medium waveform
- **Input:** SSR Standard; 0÷10V, 4÷20mA and Heater Break alarm are options
- **Firing:** Zero Crossing, Burst Firing available with analogue input only
- **Operating temperature:** 0°C to 40°C without derating
- **Approvals:** Compliant with CE and cUL (option) up to 700A
- **100 kA:** Short Circuit Current Rating (SCCR) up to 600V, 700A

Options

- Analog input: 4÷20mA or 0÷10V
- Heater Break Alarm + Current Transformer
- Integrated extrarapid fuses ≤40A
- Available on some size: Fuse alarm signal (FUMS) and 2° thermal switch

Firing

- ZC: Zero Crossing
- Burst Firing 4 / 8 / 16

ZC Firing available with analogue input ONLY

REVO S 1PH 30÷800A / 480÷600V

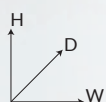

SR3

H 121xW 36xD 125 - 0,44 kg
30÷40A



SR6

H 121xW 36xD 185 - 0,61 kg
30÷40A IFH



SR12

H 269xW 93xD 170 - 3,4kg
60A



SR15

H 273xW 93xD 170 - 3,6 kg
90÷210A



S12

H 520xW 137xD 270 - 15 kg
300÷700A



S15

H 560xW 137xD 270 - 10,5 kg
800A

REVO S 1PH 60÷800A / 690V



S11

H 440xW 137xD 270 - 10,5 kg
60÷210A



S12

H 520xW 137xD 270 - 15 kg
400÷700A



S15

H 560xW 137xD 270 - 17,2 kg
800A

| REVO S 1PH | 1 | 2 | 3 | 4 | 5 | 6 | 7 | 8 | 9 | 10 | 11 | 12 | 13 | 14 | 15 | 16 |
|-------------------|---|---|---|---|---|---|---|---|---|----|----|----|----|----|----|----|
| ORDER CODE | R | S | 1 | - | - | - | - | - | - | - | - | - | - | - | - | - |

| CURRENT | | | 4 | 5 | 6 | |
|----------------|---------------|-----------|-------|------|---|----|
| Description | Size 480/600V | Size 690V | cod | note | | |
| 30A | SR3 / IFH=SR6 | -- | 0 3 0 | | | |
| 35A | SR3 / IFH=SR6 | -- | 0 3 5 | | | |
| 40A | SR3 / IFH=SR6 | -- | 0 4 0 | | | |
| 60A | SR12 | S11 | 0 6 0 | | | |
| 90A | SR15 | S11 | 0 9 0 | | | |
| 120A | SR15 | S11 | 1 2 0 | | | |
| 150A | SR15 | S11 | 1 5 0 | | | |
| 180A | SR15 | S11 | 1 8 0 | | | |
| 210A | SR15 | S11 | 2 1 0 | | | |
| 300A | S12 | S12 | 3 0 0 | | | |
| 400A | S12 | S12 | 4 0 0 | | | |
| 500A | S12 | S12 | 5 0 0 | | | |
| 600A | S12 | S12 | 6 0 0 | | | |
| 700A | S12 | S12 | 7 0 0 | | | |
| 800A | S15 | S15 | 8 0 0 | | | 10 |

| MAX VOLTAGE | | | 7 | |
|--------------------|-----|------|---|------|
| Description | cod | note | | |
| 480V | 4 | | | |
| 600V | 6 | | | |
| 690V | 7 | | | 4, 5 |

| AUX VOLTAGE SUPPLY | | | 8 | |
|--|-------------------|---|-----|------|
| ≤ 210A | | | cod | note |
| No Aux Voltage needed if HB option and/or Analog Input option NOT selected | | | 0 | 8 |
| Aux Volt 24V ac-dc needed with HB option and/or Analog Input option selected | | | 4 | 8 |
| > 210A | | | | |
| Main Supply Voltage | Aux Voltage Range | | | |
| 100/120Vac | 90÷135Vac | 1 | | 3 |
| 200/208/230/240Vac | 180÷265Vac | 2 | | 3 |
| 277Vac | 238÷330Vac | 3 | | 3 |
| 380/415/480Vac | 342÷528Vac | 5 | | 3 |
| 600Vac | 540÷759Vac | 6 | | 3 |
| 690Vac | 540÷759Vac | 7 | | 3 |

| INPUT | | | 9 | |
|--------------|-----|------|---|---|
| Description | cod | note | | |
| SSR | S | | | A |
| 0:10V dc | V | | | B |
| 4:20mA | A | | | B |

| FIRING | | | 10 | |
|---|-----|------|----|---|
| Description | cod | note | | |
| Zero Crossing | Z | | | A |
| Burst Firing 4 Cycles On at 50% Power Demand | 4 | | | 2 |
| Burst Firing 8 Cycles On at 50% Power Demand | 8 | | | 2 |
| Burst Firing 16 Cycles On at 50% Power Demand | 6 | | | 2 |
| Random (used with REVO-PC) | R | | | 7 |

| CONTROL MODE | | | 11 | |
|---------------------|-----|------|----|--|
| Description | cod | note | | |
| Open Loop | 0 | | | |

| FUSES & OPTIONS | | | 12 | |
|--|--|--|-----|------|
| ≤ 40A | | | cod | note |
| No Fuse (for units ≤ 40A) | | | 0 | |
| Extrarapid fuse + fuse holder | | | F | |
| Extrarapid fuse + fuse holder + CT | | | Y | |
| Extrarapid fuse + fuse holder + CT + HB | | | H | |
| Extrarapid fuse + fuse holder + CT + HB with Flat Cable Connection | | | X | 5, 6 |
| > 40A | | | | |
| Extrarapid fixed fuses standard (on all units > 40A) | | | F | 1 |
| Extrarapid fixed fuses standard + CT + HB | | | H | |

| FAN VOLTAGE | | | 13 | |
|---------------------------|-----|------|----|--|
| Description | cod | note | | |
| No fan < 90A | | | 0 | |
| Fan 115Vac ≥ 90A | | | 1 | |
| Fan 230Vac ≥ 90A Standard | | | 2 | |
| Fan 24Vdc ≥ 90A | | | 3 | |

| APPROVALS | | | 14 | |
|------------------------|-----|------|----|--|
| Description | cod | note | | |
| CE for European market | | | 0 | |
| CE + cUL | | | L | |

| MANUAL | | | 15 | |
|---------------|-----|------|----|--|
| Description | cod | note | | |
| None | | | 0 | |
| Italian | | | 1 | |
| English | | | 2 | |
| German | | | 3 | |
| French | | | 4 | |

| VERSION | | | 16 | |
|------------------------------|-----|------|----|---|
| Description | cod | note | | |
| Standard Version | | | 1 | |
| High Sensitivity HB below 5A | | | 5 | 9 |

Note A: Zero Crossing Firing only with SSR input

Note B: With analog input (0:10Vdc, 4:20mA) it is necessary to have the Fuse + Fuse Holder on units ≤40A

Note 1: Fixed fuses over 40A

Note 2: Available with analog input only

Note 3: Load voltage must be included in Selected Auxiliary Voltage Range for units >210A

Note 4: Available on unit ≥60A

Note 5: This unit is not available with optional UL approval

Note 6: Needs RTURS terminal units

Note 7: See REVO PC

Note 8: This option is not available with Max Voltage equal to 690V. In this case please use the other Auxiliary Voltage Supplies

Note 9: This option is available on units from 30A to 40A

Note 10: 800A unit is available with UL approval (not cUL)

REVO S 2PH

Technical Specification

- **Load type:** Normal resistance, infrared long and medium waveform
- **Input:** SSR Standard; 0÷10V, 4÷20mA and Heater Break alarm are options
- **Firing:** Zero Crossing, Burst Firing available with analogue input only
- **Operating temperature:** 0°C to 40°C without derating
- **Approvals:** Compliant with CE and cUL (option) up to 700A
- **100 kA:** Short Circuit Current Rating (SCCR) up to 600V, 700A
- **Integrated pass-through phase:** 480V-600V: all sizes S14 / 690V: all sizes S11, S13, S14

Options

- Analog input: 4÷20mA or 0÷10V
- Heater Break Alarm + Current Transformer
- Integrated extrarapid fuses ≤40A
- Available on some size: Fuse alarm signal (FUMS) and 2° thermal switch

Firing

- ZC: Zero Crossing
- Burst Firing 4 / 8 / 16

ZC Firing available with analogue input ONLY

REVO S 2PH 30÷800A / 480÷600V

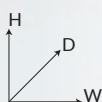

SR4

H 121 x W 72 x D 125 - 0,88 kg
30÷40A



SR7

H 121 x W 72 x D 185 - 1,22 kg
30÷40A IFH



SR15

H 273 x W 93 x D 170 - 3,6 kg
60÷90A



SR16

H 273 x W 186 x D 170 - 7,0 kg
120÷210A



S14

H 520 x W 262 x D 270 - 22 kg
300÷700A



S16

H 560 x W 275 x D 270 - 34,4 kg
800A

REVO S 2PH 60÷800A / 690V



S11

H 440 x W 137 x D 270 - 10,5 kg
60÷90A



S13

H 440 x W 262 x D 270 - 18 kg
120÷210A



S14

H 520 x W 262 x D 270 - 22 kg
300÷700A



S16

H 560 x W 275 x D 270 - 34,4 kg
800A

| | | | | | | | | | | | | | | | | |
|------------|---|---|---|---|---|---|---|---|---|----|----|----|----|----|----|----|
| REVOS 2PH | 1 | 2 | 3 | 4 | 5 | 6 | 7 | 8 | 9 | 10 | 11 | 12 | 13 | 14 | 15 | 16 |
| ORDER CODE | R | S | 2 | - | - | - | - | - | - | - | - | - | - | - | - | - |

| CURRENT | | | 4 | 5 | 6 | |
|-------------|---------------|-----------|-------|------|---|--|
| Description | Size 480/600V | Size 690V | cod | note | | |
| 30A | SR4 / IFH=SR7 | -- | 0 3 0 | | | |
| 35A | SR4 / IFH=SR7 | -- | 0 3 5 | | | |
| 40A | SR4 / IFH=SR7 | -- | 0 4 0 | | | |
| 60A | SR15 | S11 | 0 6 0 | | | |
| 75A | SR15 | -- | 0 7 5 | 7 | | |
| 90A | SR15 | S11 | 0 9 0 | 5 | | |
| 120A | SR16 | S13 | 1 2 0 | | | |
| 150A | SR16 | S13 | 1 5 0 | | | |
| 180A | SR16 | S13 | 1 8 0 | | | |
| 210A | SR16 | S13 | 2 1 0 | | | |
| 300A | S14 | S14 | 3 0 0 | | | |
| 400A | S14 | S14 | 4 0 0 | | | |
| 450A | S14 | S14 | 4 5 0 | | | |
| 500A | S14 | S14 | 5 0 0 | | | |
| 600A | S14 | S14 | 6 0 0 | | | |
| 700A | S14 | S14 | 7 0 0 | | | |
| 800A | S16 | S16 | 8 0 0 | 7 | | |

| MAX VOLTAGE | | | 7 | |
|-------------|-----|------|---|--|
| Description | cod | note | | |
| 480V | 4 | | | |
| 600V | 6 | | | |
| 690V | 7 | 4, 5 | | |

| AUX VOLTAGE SUPPLY | | | 8 | |
|--|-------------------|---|------|------|
| ≤ 210A | | | code | note |
| No Aux Voltage needed if HB option and/or Analog Input option NOT selected | | | 0 | 8 |
| Aux Volt 24V ac-dc needed with HB option and/or Analog Input option selected | | | 4 | 8 |
| > 210A | | | | |
| Main Supply Voltage | Aux Voltage Range | | | |
| 100/120Vac | 90÷135Vac | 1 | 3 | |
| 200/208/230/240Vac | 180÷265Vac | 2 | 3 | |
| 277Vac | 238÷330Vac | 3 | 3 | |
| 380/415/480Vac | 342÷528Vac | 5 | 3 | |
| 600Vac | 540÷759Vac | 6 | 3 | |
| 690Vac | 540÷759Vac | 7 | 3 | |

| INPUT | | | 9 | |
|-------------|-----|------|---|--|
| Description | cod | note | | |
| SSR | S | A | | |
| 0:10V dc | V | B | | |
| 4:20mA | A | B | | |

| FIRING | | | 10 | |
|---|-----|------|----|--|
| Description | cod | note | | |
| Zero Crossing | Z | A | | |
| Burst Firing 4 Cycles On at 50% Power Demand | 4 | 2 | | |
| Burst Firing 8 Cycles On at 50% Power Demand | 8 | 2 | | |
| Burst Firing 16 Cycles On at 50% Power Demand | 6 | 2 | | |

| CONTROL MODE | | | 11 | |
|--------------|-----|------|----|--|
| Description | cod | note | | |
| Open Loop | 0 | | | |

| FUSES & OPTION | | | 12 | |
|--|--|--|------|------|
| ≤ 40A | | | code | note |
| No Fuse (for units ≤ 40A) | | | 0 | |
| Extrapid fuse + fuse holder | | | F | |
| Extrapid fuse + fuse holder + CT | | | Y | |
| Extrapid fuse + fuse holder + CT + HB | | | H | |
| Extrapid fuse + fuse holder + CT + HB with Flat Cable Connection | | | X | 5, 6 |
| > 40A | | | | |
| Extrapid fixed fuses standard (on all units > 40A) | | | F | 1 |
| Extrapid fixed fuses standard + CT + HB | | | H | |

| FAN VOLTAGE | | | 13 | |
|------------------------|-----|------|----|--|
| Description | cod | note | | |
| No fan <60A | 0 | | | |
| Fan 115V ≥60A | 1 | | | |
| Fan 230V ≥60A Standard | 2 | | | |
| Fan 24Vdc ≥60A | 3 | | | |

| APPROVALS | | | 14 | |
|------------------------|-----|------|----|--|
| Description | cod | note | | |
| CE for European market | 0 | | | |
| CE + cUL | L | 7 | | |

| MANUAL | | | 15 | |
|-------------|-----|------|----|--|
| Description | cod | note | | |
| None | 0 | | | |
| Italian | 1 | | | |
| English | 2 | | | |
| German | 3 | | | |
| French | 4 | | | |

| VERSION | | | 16 | |
|------------------------------|-----|------|----|--|
| Description | cod | note | | |
| Standard Version | 1 | | | |
| High Sensitivity HB below 5A | 5 | 9 | | |

Note A: Zero Crossing Firing only with SSR input

Note B: With analog input (0:10Vdc, 4:20mA) it is necessary to have the Fuse + Fuse Holder on units ≤40A

Note 1: Fixed Fuses over 40A

Note 2: Available with analog input only

Note 3: Load voltage must be included in Selected Auxiliary Voltage Range for unit >210A

Note 4: Available on unit ≥60A

Note 5: This unit is not available with optional UL approval

Note 6: Needs RTURS terminal units

Note 7: 75A unit is available with cUL approval only, 800A unit is available with UL approval (not cUL)

Note 8: This option is not available with Max Voltage equal to 690V. In this case please use the other Auxiliary Voltage Supplies

Note 9: This option is available on units from 30A to 40A

REVO S 3PH

Technical Specification

- **Load type:** Normal resistance, infrared long and medium waveform
- **Input:** SSR Standard; 0÷10V, 4÷20mA and Heater Break alarm are options
- **Firing:** Zero Crossing, Burst Firing available with analogue input only
- **Operating temperature:** 0°C to 40°C without derating
- **Approvals:** Compliant with CE and cUL (option) up to 700A
- **100 kA:** Short Circuit Current Rating (SCCR) up to 600V, 700A

Options

- Analog input: 4÷20mA or 0÷10V
- Heater Break Alarm + Current Transformer
- Integrated extrarapid fuses ≤40A
- Available on some size: Fuse alarm signal (FUMS) and 2° thermal switch

Firing

- ZC: Zero Crossing
- Burst Firing 4 / 8 / 16

ZC Firing available with analogue input ONLY

REVO S 3PH 30÷800A / 480V-600V

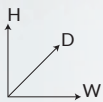

SR5

H 121 x W 108 x D 125 - 1,32 kg
30÷40A



SR8

H 121 x W 108 x D 185 - 1,83 kg
30÷40A IFH



SR16

H 269 x W 186 x D 170 - 6,8kg
60÷90A



SR17

H 273 x W 279 x D 170 - 10,6 kg
120÷210A



S14

H 520 x W 262 x D 270 - 22 kg
300÷500A



S17

H 560 x W 411 x D 270 - 51,6 kg
800A

REVO S 3PH 60÷800A / 690V



S11

H 440 x W 137 x D 270 - 10,5 kg
60÷90A



S13

H 440 x W 262 x D 270 - 18 kg
120÷210A



S14

H 520 x W 262 x D 270 - 22 kg
300÷500A



S17

H 560 x W 411 x D 270 - 51,6 kg
800A

| | | | | | | | | | | | | | | | | |
|------------|---|---|---|---|---|---|---|---|---|----|----|----|----|----|----|----|
| REVO S 3PH | 1 | 2 | 3 | 4 | 5 | 6 | 7 | 8 | 9 | 10 | 11 | 12 | 13 | 14 | 15 | 16 |
| ORDER CODE | R | S | 3 | - | - | - | - | - | - | - | - | - | - | - | - | - |

| CURRENT | | | 4 | 5 | 6 |
|-------------|---------------|-----------|-------|------|---|
| Description | Size 480/600V | Size 690V | cod | note | |
| 30A | SR5 / IFH=SR8 | -- | 0 3 0 | | |
| 35A | SR5 / IFH=SR8 | -- | 0 3 5 | | |
| 40A | SR5 / IFH=SR8 | -- | 0 4 0 | | |
| 60A | SR16 | S11 | 0 6 0 | | |
| 75A | SR16 | -- | 0 7 5 | 7 | |
| 90A | SR16 | S11 | 0 9 0 | 5 | |
| 120A | SR17 | S13 | 1 2 0 | | |
| 150A | SR17 | S13 | 1 5 0 | | |
| 180A | SR17 | S13 | 1 8 0 | | |
| 210A | SR17 | S13 | 2 1 0 | | |
| 300A | S14 | S14 | 3 0 0 | | |
| 350A | S14 | S14 | 3 5 0 | | |
| 400A | S14 | S14 | 4 0 0 | | |
| 450A | S14 | S14 | 4 5 0 | | |
| 500A | S14 | S14 | 5 0 0 | | |
| 800A | S17 | S17 | 8 0 0 | 7 | |

| MAX VOLTAGE | | | 7 |
|-------------|-----|------|---|
| Description | cod | note | |
| 480V | 4 | | |
| 600V | 6 | | |
| 690V | 7 | 4,5 | |

| AUX VOLTAGE SUPPLY | | | 8 |
|--|-------------------|------|---|
| Description | cod | note | |
| ≤ 210A | | | |
| No Aux Voltage needed if HB option and/or Analog Input option NOT selected | 0 | 8 | |
| Aux Volt 24V ac-dc needed with HB option and/or Analog Input option selected | 4 | 8 | |
| > 210A | | | |
| Main Supply Voltage | Aux Voltage Range | | |
| 100/120Vac | 90÷135Vac | 1 | 3 |
| 200/208/230/240Vac | 180÷265Vac | 2 | 3 |
| 277Vac | 238÷330Vac | 3 | 3 |
| 380/415/480Vac | 342÷528Vac | 5 | 3 |
| 600Vac | 540÷759Vac | 6 | 3 |
| 690Vac | 540÷759Vac | 7 | 3 |

| INPUT | | | 9 |
|-------------|-----|------|---|
| Description | cod | note | |
| SSR | S | A | |
| 0:10V dc | V | B | |
| 4:20mA | A | B | |

| FIRING | | | 10 |
|---|-----|------|----|
| Description | cod | note | |
| Zero Crossing | Z | A | |
| Burst Firing 4 Cycles On at 50% Power Demand | 4 | 2 | |
| Burst Firing 8 Cycles On at 50% Power Demand | 8 | 2 | |
| Burst Firing 16 Cycles On at 50% Power Demand | 6 | 2 | |

| CONTROL MODE | | | 11 |
|--------------|-----|------|----|
| Description | cod | note | |
| Open Loop | 0 | | |

| FUSES & OPTION | | | 12 |
|--|-----|------|----|
| Description | cod | note | |
| ≤ 40A | | | |
| No Fuse (for units ≤ 40A) | 0 | | |
| Extrapid fuse + fuse holder | F | | |
| Extrapid fuse + fuse holder + CT | Y | | |
| Extrapid fuse + fuse holder + CT + HB | H | | |
| Extrapid fuse + fuse holder + CT + HB with Flat Cable Connection | X | 5,6 | |
| > 40A | | | |
| Extrapid fixed fuses standard (on all units > 40A) | F | 1 | |
| Extrapid fixed fuses standard + CT + HB | H | | |

| FAN VOLTAGE | | | 13 |
|------------------------|-----|------|----|
| Description | cod | note | |
| No fan <60A | 0 | | |
| Fan 115V ≥60A | 1 | | |
| Fan 230V ≥60A Standard | 2 | | |
| Fan 24Vdc ≥60A | 3 | | |

| APPROVALS | | | 14 |
|------------------------|-----|------|----|
| Description | cod | note | |
| CE for European market | 0 | | |
| CE + cUL | L | 7 | |

| MANUAL | | | 15 |
|-------------|-----|------|----|
| Description | cod | note | |
| None | 0 | | |
| Italian | 1 | | |
| English | 2 | | |
| German | 3 | | |
| French | 4 | | |

| VERSION | | | 16 |
|------------------------------|-----|------|----|
| Description | cod | note | |
| Standard Version | 1 | | |
| High Sensitivity HB below 5A | 5 | 9 | |

Note A: Zero Crossing Firing only with SSR input

Note B: With analog input (0:10Vdc, 4:20mA) it is necessary to have the Fuse + Fuse Holder on units ≤ 40A

Note 1: Fixed Fuses over 40A

Note 2: Available with analog input only

Note 3: Load voltage must be included in Selected Auxiliary Voltage Range for units >210A

Note 4: Available on unit ≥60A

Note 5: This unit is not available with optional UL approval

Note 6: Needs RTURS terminal units

Note 7: 75A unit is available with cUL approval only, 800A unit is available with UL approval (not cUL)

Note 8: This option is not available with Max Voltage equal to 690V. In this case please use the other Auxiliary Voltage Supplies

Note 9: This option is available on units from 30A to 40A

REVO SX

230V



SR2-230V
H 121xW 36xD 87
0,27 kg

480V



SR2-480V
H 121xW 48xD 87
0,27 kg

Technical Specification

- Available in three versions
- Each unit includes extrarapid fuse and fuse holder, thyristor and heat sink with its own firing circuit
- Zero Crossing firing
- Isolated SSR input
- LED for On/Off status indication
- LED for fuse failure indication
- Separate screw connection terminals for Power and Inputs
- Din rail mounting or screw mounting
- Can be used in multi-zone applications and low power such as Thermoforming, Blow Moulding and Hot Runners

Example control connection diagram

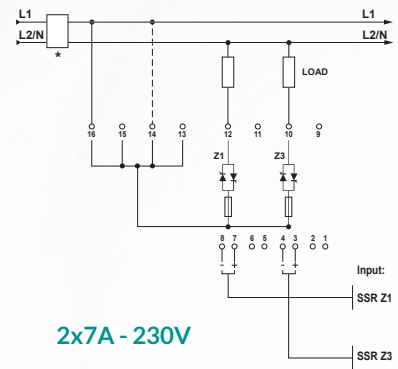
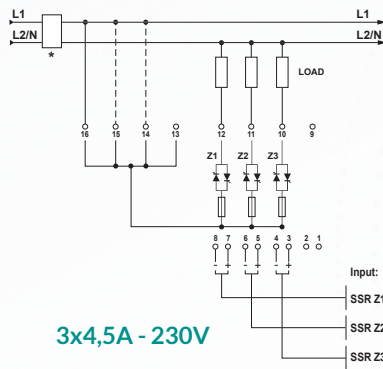
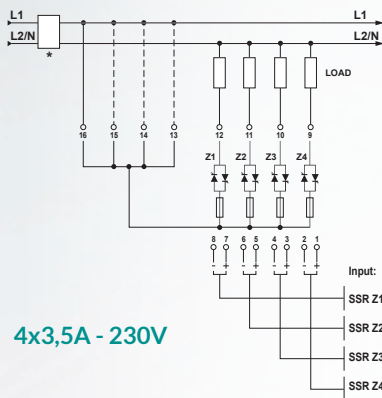

| REVO SX | 1 | 2 | 3 | 4 | 5 | 6 | 7 | 8 | 9 | 10 | 11 | 12 | 13 | 14 | 15 | 16 | | | | | |
|---|-----|---|---|------|------|---|---|---|---|----|----|----|-------------------------------|----|----|-----|--|--|------|--|--|
| ORDER CODE | R | S | X | - | - | - | - | - | - | - | - | - | - | - | - | - | | | | | |
| NUMBER OF ZONES X CURRENT RATING | 4 | 5 | 6 | | | | | | | | | 12 | | | | | | | | | |
| Description | cod | | | note | | | | | | | | | Description | | | cod | | | note | | |
| 4 zones 3,5A each | 4 | 0 | 3 | | | | | | | | | | Extrarapid fuse + fuse holder | | | F | | | | | |
| 3 zone 4,5A each | 3 | 0 | 4 | | | | | | | | | | | | | | | | | | |
| 2 zone 7A each | 2 | 0 | 7 | | | | | | | | | | | | | | | | | | |
| MAX VOLTAGE | | | | 7 | | | | | | | | | | | | | | | | | |
| Description | | | | cod | note | | | | | | | | | | | | | | | | |
| 230V | | | | 2 | | | | | | | | | | | | | | | | | |
| 480V | | | | 4 | | | | | | | | | | | | | | | | | |
| VOLTAGE SUPPLY AUX | | | | 8 | | | | | | | | | | | | | | | | | |
| Description | | | | cod | note | | | | | | | | | | | | | | | | |
| No Auxiliary Voltage with 230V | | | | 0 | | | | | | | | | | | | | | | | | |
| 24 Vdc with 480V | | | | 4 | | | | | | | | | | | | | | | | | |
| INPUT | | | | 9 | | | | | | | | | | | | | | | | | |
| Description | | | | cod | note | | | | | | | | | | | | | | | | |
| SSR | | | | S | | | | | | | | | | | | | | | | | |
| FIRING | | | | 10 | | | | | | | | | | | | | | | | | |
| Description | | | | cod | note | | | | | | | | | | | | | | | | |
| Zero Crossing | | | | Z | | | | | | | | | | | | | | | | | |
| Random (used with REVO-PC) | | | | R | | | | | | | | | | | | | | | | | |
| CONTROL MODE | | | | 11 | | | | | | | | | | | | | | | | | |
| Description | | | | cod | note | | | | | | | | | | | | | | | | |
| Open Loop | | | | 0 | | | | | | | | | | | | | | | | | |
| FAN VOLTAGE | | | | 13 | | | | | | | | | | | | | | | | | |
| Description | | | | cod | note | | | | | | | | | | | | | | | | |
| No fan | | | | 0 | | | | | | | | | | | | | | | | | |
| APPROVALS | | | | 14 | | | | | | | | | | | | | | | | | |
| Description | | | | cod | note | | | | | | | | | | | | | | | | |
| CE for European market | | | | 0 | | | | | | | | | | | | | | | | | |
| MANUAL | | | | 15 | | | | | | | | | | | | | | | | | |
| Description | | | | cod | note | | | | | | | | | | | | | | | | |
| None | | | | 0 | | | | | | | | | | | | | | | | | |
| Italian | | | | 1 | | | | | | | | | | | | | | | | | |
| English | | | | 2 | | | | | | | | | | | | | | | | | |
| German | | | | 3 | | | | | | | | | | | | | | | | | |
| French | | | | 4 | | | | | | | | | | | | | | | | | |
| VERSION | | | | 16 | | | | | | | | | | | | | | | | | |
| Description | | | | cod | note | | | | | | | | | | | | | | | | |
| Version 1 | | | | 1 | | | | | | | | | | | | | | | | | |



Technical Specification

- Available in different versions with two or three independent channels
- Currents: 50A, 60A, 75A, 90A
- 480V or 600V max voltage
- Integrated extrarapid fuses and thyristors with its own firing circuit
- Single heat sink
- Zero Crossing firing
- Isolated input
- Screw mounting
- Can be used in multi-zone applications in combination with REVO PC series to get power synchronization, communication, measurement and diagnostic

SR25
H 180 x W 116 x D 183
2,35 kg

Example control connection diagram

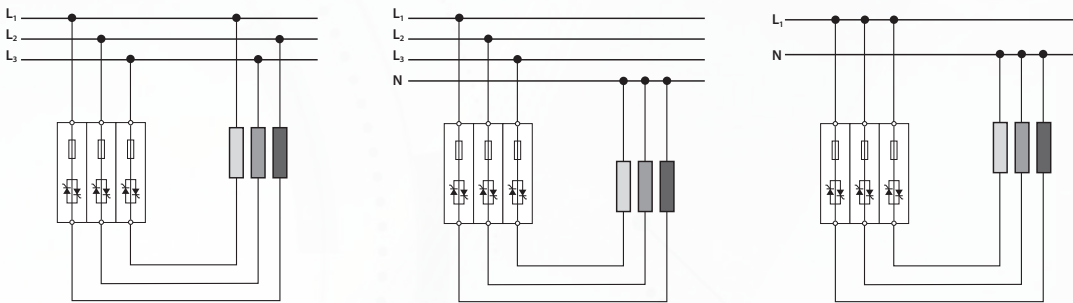

| REVO SX | 1 | 2 | 3 | 4 | 5 | 6 | 7 | 8 | 9 | 10 | 11 | 12 | 13 | 14 | 15 | 16 | |
|---|---|---|---|-----------|---|------|---|---|---|----|-----------|----|------|----|----|----|--|
| ORDER CODE | R | S | X | - | - | - | - | - | - | - | - | - | - | - | - | - | |
| NUMBER OF ZONES X CURRENT RATING | | | | 4 | 5 | 6 | | | | | | | | | | | |
| Description | | | | cod | | note | | | | | | | | | | | |
| 2 zones 50A each | | | | 2 | 5 | 0 | | | | | | | | | | | |
| 2 zones 60A each | | | | 2 | 6 | 0 | | | | | | | | | | | |
| 2 zones 75A each | | | | 2 | 7 | 5 | | | | | | | | | | | |
| 2 zones 90A each | | | | 2 | 9 | 0 | | | | | | | | | | | |
| 3 zones 50A each | | | | 3 | 5 | 0 | | | | | | | | | | | |
| 3 zones 60A each | | | | 3 | 6 | 0 | | | | | | | | | | | |
| 3 zones 75A each | | | | 3 | 7 | 5 | | | | | | | | | | | |
| 3 zones 90A each | | | | 3 | 9 | 0 | | | | | | | | | | | |
| MAX VOLTAGE | | | | 7 | | | | | | | | | | | | | |
| Description | | | | cod | | note | | | | | | | | | | | |
| 480V | | | | 4 | | | | | | | | | | | | | |
| 600V | | | | 6 | | | | | | | | | | | | | |
| VOLTAGE SUPPLY AUX | | | | 8 | | | | | | | | | | | | | |
| Description | | | | cod | | note | | | | | | | | | | | |
| No Auxiliary Voltage | | | | 0 | | | | | | | | | | | | | |
| INPUT | | | | 9 | | | | | | | | | | | | | |
| Description | | | | cod | | note | | | | | | | | | | | |
| SSR | | | | S | | | | | | | | | | | | | |
| FIRING | | | | 10 | | | | | | | | | | | | | |
| Description | | | | cod | | note | | | | | | | | | | | |
| Zero Crossing | | | | Z | | | | | | | | | | | | | |
| CONTROL MODE | | | | | | | | | | | 11 | | | | | | |
| Description | | | | | | | | | | | cod | | note | | | | |
| Open Loop | | | | | | | | | | | 0 | | | | | | |
| FUSES & OPTION | | | | | | | | | | | 12 | | | | | | |
| Description | | | | | | | | | | | cod | | note | | | | |
| Extrarapid fuse & fuse holder | | | | | | | | | | | F | | | | | | |
| FAN VOLTAGE | | | | | | | | | | | 13 | | | | | | |
| Description | | | | | | | | | | | cod | | note | | | | |
| Standard: 24Vdc fan | | | | | | | | | | | 3 | | | | | | |
| APPROVALS | | | | | | | | | | | 14 | | | | | | |
| Description | | | | | | | | | | | cod | | note | | | | |
| CE for European market | | | | | | | | | | | 0 | | | | | | |
| MANUAL | | | | | | | | | | | 15 | | | | | | |
| Description | | | | | | | | | | | cod | | note | | | | |
| None | | | | | | | | | | | 0 | | | | | | |
| Italian | | | | | | | | | | | 1 | | | | | | |
| English | | | | | | | | | | | 2 | | | | | | |
| German | | | | | | | | | | | 3 | | | | | | |
| French | | | | | | | | | | | 4 | | | | | | |
| VERSION | | | | | | | | | | | 16 | | | | | | |
| Description | | | | | | | | | | | cod | | note | | | | |
| Version 1 | | | | | | | | | | | 1 | | | | | | |

REVEX

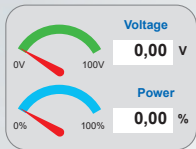

Configurator software

TIA PORTAL V16

SIEMENS

Libraries
(only for RS485)



Main features

Ready-to-use unit configured according to order code, choosing only the options you need to build your own “Customised Unit”.

REVEX is a universal unit that allows you to have:

- Input signal in digital mode, no link jumpers inside
- Firing: Single Cycle, Half Cycle, Burst Firing, Phase Angle, Delayed Triggering, different types of adjustable ramp
- Control mode (V, V2, I, I2, VxI)
- Communication RS485 with Modbus® protocol std
- Two Analog input
- Two Digital input
- USB port for programming, configuration and remote management
- **Guided configuration via free software**, available on www.cdautomation.com
- Siemens **TIA Portal Libraries** for data exchange with our products (from V16) (only for RS485)

Load type

Resistive / Inductive / Infrared lamp short wave (IRSW) and fast medium wave (IRMW) / Molybdenum Disilicide elements (MoSi2) / Silicon Carbide elements (SiC)

Cannot be used for capacitive loading. For information contact our technical department

Industrial applications

- | | | | |
|---------------------------------|---------------------|---------------------|------------------------|
| ● Petrochemicals | ● Autoclaves | ● Polysilicon | ● Automobile |
| ● Platform for oil extraction | ● Electric furnaces | ● Chemical | ● Paint drying |
| ● Conventional power generator | ● Galvanic process | ● Plastic machinery | ● UV drying |
| ● Chemicals and pharmaceuticals | ● Glass industry | ● Packing machinery | ● Car internal fitting |

REVEX - FEATURES

| | Description | REVEX 1PH | REVEX 2PH | REVEX 3PH | REVEX PA |
|-------------------------|--|-------------|-------------|-------------|-------------|
| | CODE | RX1 | RX2 | RX3 | RXP |
| Load type | Max voltage 480V | ● | ● | ● | ● |
| | Max voltage 600V | ● | ● | ● | ● |
| | Single phase | ● | | | |
| | 3 phase load star no neutral or delta | | ● | ● | ● |
| | 3 phase load star with neutral | | | ● | ● |
| | 3 phase load open delta | ● | | | |
| Input | SSR 4:30VDC | ● | ● | ● | ● |
| | 4:20 mA | ● | ● | ● | ● |
| | 0:10 Vdc | ● | ● | ● | ● |
| | Potentiometer | ● | ● | ● | ● |
| Firing | Single Cycle | ● | | | |
| | Half Cycle | ● | | | |
| | Burst Firing | ● | ● | ● | ● |
| | Phase Angle | ● | | | ● |
| | Delayed Triggering | ● | | | ● |
| | Zero Crossing | ● | ● | ● | ● |
| Control mode (feedback) | Open Loop | ● | ● | ● | ● |
| | V | ● | ● | ● | ● |
| | V ² | ● | ● | ● | ● |
| | I | ● | ● | ● | ● |
| | I ² | ● | ● | ● | ● |
| | V x I | ● | ● | ● | ● |
| Options | Current limit (CL) | ○ | | | ○ |
| | Heater Break Alarm + SCR Short Circuit | ○ | ○ | ○ | ○ |
| | Fuse | ○ | ○ | ○ | ○ |
| | Display | ○ | ○ | ○ | ○ |
| | Load Analyzer | ● | ● | ● | ● |
| Communication | Modbus® RTU | ● | ● | ● | ● |
| Current | Current | SIZE | SIZE | SIZE | SIZE |
| | | 600V Max | 600V Max | 600V Max | 600V Max |
| | 30 | SR6 | SR9 | SR10 | |
| | 35 | SR6 | SR9 | SR10 | SR25 |
| | 40 | SR6 | SR9 | SR10 | |
| | 50 | | | | SR25 |
| | 60 | SR24 | SR25 | SR25 | |
| | 75 | | | | SR25 |
| | 90 | SR25 | SR25 | SR25 | SR25 |
| | 120 | SR15 | SR16 | SR17 | |
| | 150 | SR15 | SR16 | SR17 | |
| | 180 | SR15 | SR16 | SR17 | |
| | 210 | SR15 | SR16 | SR17 | |
| 280 | S10 | 2xS10 | | | |

● Standard ○ Option ■ CE standard

REVEX 1PH

Technical Specification

- **Load type:** Normal resistance, infrared short, medium and long, transformer primary, cold resistance and SiC elements
- **Input:** 4:20mA, 0:10V, SSR, with Modbus® RTU standard
- **Firing:** Half Cycle, Single Cycle, Burst Firing, Delayed Triggering, Phase Angle with or without Soft Start
- **Control mode:** Voltage, Current and Power (V-V²-I-I²-VxI) or external feedback
- **Communication:** RS485 port RTU Modbus® Protocol
- **USB:** Integrated port for configuration in safety mode (no load and auxiliary voltage needed). Unit powered through USB
- **Approvals:** Compliant with CE
- **Dual Current Limit:** For peak or RMS value

Attention

- Phase Angle available only on 1PH units
- Delayed Triggering available only on 1PH units
- For three-phase solutions (3PH) with Phase Angle use **REVEX PA** (pag 22)

Options

- All options are shown below with the relevant model code
- HB Alarm to diagnose partial or total load failure and thyristor short circuit

REVEX 1PH 30÷280A / 480÷600V

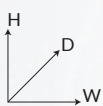

SR6

H 121xW 36xD 185 - 0,61 kg
30÷40A



SR24

H 132xW 116xD 183 - 2,10 kg
60÷90A



SR15

H 273xW 93xD 170 - 3,6 kg
120÷210A



S10

H 350xW 120xD 230 - 6,50 kg
280A

| REVEX 1PH | 1 | 2 | 3 | 4 | 5 | 6 | 7 | 8 | 9 | 10 | 11 | 12 | 13 | 14 | 15 | 16 |
|-------------------|---|---|---|---|---|---|---|---|---|----|----|----|----|----|----|----|
| ORDER CODE | R | X | 1 | - | - | - | - | - | - | - | - | - | - | - | - | - |

| CURRENT / FUSES | | | 4 | 5 | 6 |
|-----------------|-------------------------------------|------|------|---|---|
| Description | Size | cod | note | | |
| 30A | Extrarapid fixed fuses not included | SR6 | 0 | 3 | 0 |
| 35A | Extrarapid fixed fuses not included | SR6 | 0 | 3 | 5 |
| 40A | Extrarapid fixed fuses not included | SR6 | 0 | 4 | 0 |
| 60A | Extrarapid fixed fuses included | SR24 | 0 | 6 | 0 |
| 90A | Extrarapid fixed fuses included | SR24 | 0 | 9 | 0 |
| 120A | Extrarapid fixed fuses included | SR15 | 1 | 2 | 0 |
| 150A | Extrarapid fixed fuses included | SR15 | 1 | 5 | 0 |
| 180A | Extrarapid fixed fuses included | SR15 | 1 | 8 | 0 |
| 210A | Extrarapid fixed fuses included | SR15 | 2 | 1 | 0 |
| 280A | Extrarapid fixed fuses included | S10 | 2 | 8 | 0 |

| MAX VOLTAGE | | 7 |
|-------------|-----|------|
| Description | cod | note |
| 480V | 4 | |
| 600V | 6 | |

| MAIN SUPPLY VOLTAGE | | 8 |
|---------------------|-----|------|
| Description | cod | note |
| 24Vdc | 4 | |

| INPUT | | 9 |
|-------------|-----|------|
| Description | cod | note |
| SSR | S | |
| 0:20mA | B | |
| 4:20mA | A | |
| 0:10V | V | |
| 10KPot | K | |

| FIRING | START OPTION | 10 | |
|--------------------|---|-----|------|
| Description | Description | cod | note |
| Single Cycle | No Soft Start | C | |
| | Linear Soft Start | S | |
| Half Cycle | No Soft Start | H | |
| | Linear Soft Start | L | |
| | Soft Start for short wave Infrared Lamp | I | |
| Burst Firing | No Soft Start | B | |
| | Linear Soft Start | J | |
| Phase Angle | No Soft Start | P | |
| | Linear Soft Start | E | |
| Delayed Triggering | No Soft Start | D | |
| | Linear Soft Start | T | |
| Zero Crossing | No Soft Start | Z | |
| | Linear Soft Start | R | |

| CONTROL MODE | | 11 |
|----------------------------------|-----|------|
| Description | cod | note |
| Open Loop | 0 | |
| Voltage | U | |
| Voltage Square (V ²) | Q | |
| Current | I | |
| Current Square (I ²) | A | |
| Power VxI | W | |
| External Feedback | X | |

| OPTION | | 12 |
|------------------------|-----|------|
| Description | cod | note |
| Option code: see table | ... | |

| FAN VOLTAGE | | 13 |
|----------------|-----|------|
| Description | cod | note |
| No fan <90A | 0 | |
| Fan 24Vdc ≥90A | 3 | |

| APPROVALS | | 14 |
|------------------------|-----|------|
| Description | cod | note |
| CE for European market | 0 | |

| LOAD TYPE | | 15 |
|--|-----|------|
| Description | cod | note |
| 1PH normal resistance | 0 | |
| 1PH IRSW infrared short wave | 1 | |
| 1PH MoSi2 heaters | 2 | 2 |
| 1PH SiC heaters | 3 | |
| 1PH transformer coupled with normal resistance | 4 | 1 |
| 1PH transformer coupled with MoSi2 heaters | 5 | 1 |
| 1PH transformer coupled with SiC heaters | 6 | 1 |
| 1PH transformer coupled with UV heaters | 7 | 1 |

| VERSION | | 16 |
|------------------------------------|-----|------|
| Description | cod | note |
| Standard Version - N°1 Modbus® RTU | 0 | |

Note 1: This configuration is possible only with Delayed Triggering or Phase Angle Firing

Note 2: This configuration is possible only with Phase Angle Firing

Option Code (digit 12)

| REVEX 1PH | Current Limit | Heater Break | Display | Cod (digit 12) |
|-----------|---------------|--------------|---------|----------------|
| | Y | Y | Y | 0 |
| Y | Y | N | 2 | |
| Y | N | N | 3 | |
| N | N | N | 4 | |
| Y | N | Y | 6 | |
| N | N | Y | 7 | |
| N | Y | Y | 9 | |
| N | Y | N | D | |

| REVEX 1PH | Current Limit | Heater Break | Fuse | Display | Cod (digit 12) |
|-----------|---------------|--------------|------|---------|----------------|
| | Y | Y | Y | Y | 0 |
| Y | Y | Y | N | 1 | |
| Y | Y | N | N | 2 | |
| Y | N | N | N | 3 | |
| N | N | N | N | 4 | |
| Y | Y | N | Y | 5 | |
| Y | N | N | Y | 6 | |
| N | N | N | Y | 7 | |
| N | Y | Y | N | 8 | |
| N | Y | N | Y | 9 | |
| N | N | Y | Y | A | |
| N | N | Y | N | B | |
| N | Y | Y | Y | C | |
| N | Y | N | N | D | |
| Y | N | Y | N | E | |
| Y | N | Y | Y | F | |

N Option you want remove

Y It serves my project

REVEX 2PH

Technical Specification

- **Load type:** Normal resistance, infrared short, medium and long waveform
- **Input:** 4:20mA, 0:10V, SSR, with Modbus® RTU standard
- **Firing:** Burst Firing, Zero Crossing
- **Control mode:** Voltage, Current and Power (V-V²-I-I²-VxI) or external feedback
- **Communication:** RS485 port RTU Modbus® Protocol
- **USB:** Integrated port for configuration in safety mode (no load and auxiliary voltage needed). Unit powered through USB
- **Approvals:** Compliant with CE
- **Dual Current Limit:** For peak or RMS value

Attention

- Phase Angle available only on 1PH units
- Delayed Triggering available only on 1PH units
- For three-phase solutions (3PH) with Phase Angle use **REVEX PA** (pag 22)

Options

- All options are shown below with the relevant model code
- HB Alarm to diagnose partial or total load failure and thyristor short circuit

REVEX 2PH 30÷280A / 480÷600V

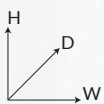

SR9

H 121 x W 72 x D 185 - 1,15 kg
30÷40A



SR25

H 165 x W 116 x D 183 - 2,35 kg
60÷90A



SR16

H 273 x W 186 x D 170 - 7,0 kg
120÷210A



2xS10

H 350 x W 240 x D 230 - 12,70 kg
280A

| | | | | | | | | | | | | | | | | |
|------------|---|---|---|---|---|---|---|---|---|----|----|----|----|----|----|----|
| REVEX 2PH | 1 | 2 | 3 | 4 | 5 | 6 | 7 | 8 | 9 | 10 | 11 | 12 | 13 | 14 | 15 | 16 |
| ORDER CODE | R | X | 2 | - | - | - | - | - | - | - | - | - | - | - | - | - |

| CURRENT / FUSES | | | 4 | 5 | 6 |
|-----------------|-------------------------------------|-------|------|---|---|
| Description | Size | cod | note | | |
| 30A | Extrarapid fixed fuses not included | SR9 | 0 | 3 | 0 |
| 35A | Extrarapid fixed fuses not included | SR9 | 0 | 3 | 5 |
| 40A | Extrarapid fixed fuses not included | SR9 | 0 | 4 | 0 |
| 60A | Extrarapid fixed fuses included | SR25 | 0 | 6 | 0 |
| 90A | Extrarapid fixed fuses included | SR25 | 0 | 9 | 0 |
| 120A | Extrarapid fixed fuses included | SR16 | 1 | 2 | 0 |
| 150A | Extrarapid fixed fuses included | SR16 | 1 | 5 | 0 |
| 180A | Extrarapid fixed fuses included | SR16 | 1 | 8 | 0 |
| 210A | Extrarapid fixed fuses included | SR16 | 2 | 1 | 0 |
| 280A | Extrarapid fixed fuses included | 2xS10 | 2 | 8 | 0 |

| MAX VOLTAGE | | 7 |
|-------------|-----|------|
| Description | cod | note |
| 480V | 4 | |
| 600V | 6 | |

| MAIN SUPPLY VOLTAGE | | 8 |
|---------------------|-----|------|
| Description | cod | note |
| 24Vdc | 4 | |

| INPUT | | 9 |
|-------------|-----|------|
| Description | cod | note |
| SSR | S | |
| 0:20mA | B | |
| 4:20mA | A | |
| 0:10V | V | |
| 10KPot | K | |

| FIRING | START OPTION | 10 | |
|---------------|---------------|-----|------|
| Description | Description | cod | note |
| Burst Firing | No Soft Start | B | |
| Zero Crossing | No Soft Start | Z | |

| CONTROL MODE | | 11 |
|----------------------------------|-----|------|
| Description | cod | note |
| Open Loop | 0 | |
| Voltage | U | |
| Voltage Square (V ²) | Q | |
| Current | I | |
| Current Square (I ²) | A | |
| Power VxI | W | |
| External Feedback | X | |

| OPTION | | 12 |
|------------------------|-----|------|
| Description | cod | note |
| Option code: see table | ... | |

| FAN VOLTAGEE | | 13 |
|----------------|-----|------|
| Description | cod | note |
| No fan <60A | 0 | |
| Fan 24Vdc ≥60A | 3 | |

| APPROVALS | | 14 |
|------------------------|-----|------|
| Description | cod | note |
| CE for European market | 0 | |

| LOAD TYPE | | 15 |
|--|-----|------|
| Description | cod | note |
| Normal resistive load with 3 phase star without neutral connection | 0 | |
| Normal resistive load with 3 phase delta connection | 1 | |
| IRSW infrared short wave with 3 phase star connection | 2 | |
| IRSW Infrared Short wave with 3 phase delta connection | 3 | |

| VERSION | | 16 |
|--|-----|------|
| Description | cod | note |
| Standard Version - N°1 Modbus® RTU std. 30-40A / 120-280A | 0 | |
| 60A-90A only: Version from 2021 (compact unit) N°1 Modbus® RTU std. | 1 | |

Option Code (digit 12)

| REVEX 2PH | Heater Break | Display | Cod (digit 12) |
|-----------|--------------|---------|----------------|
| 30A - 40A | Y | Y | 0 |
| | Y | N | 2 |
| | N | N | 3 |
| | N | Y | 5 |
| | N | N | |

| REVEX 2PH | Heater Break | Fuse | Display | Cod (digit 12) |
|------------|--------------|------|---------|----------------|
| 60A - 280A | Y | Y | Y | 0 |
| | Y | Y | N | 1 |
| | Y | N | N | 2 |
| | N | N | N | 3 |
| | Y | N | Y | 4 |
| | N | N | Y | 5 |
| | N | Y | Y | 6 |
| N | Y | N | 7 | |

N Option you want remove

Y It serves my project

REVEX 3PH

Technical Specification

- **Load type:** Normal resistance, infrared short, medium and long waveform
- **Input:** 4:20mA, 0:10V, SSR, with Modbus® RTU standard
- **Firing:** Burst Firing, Zero Crossing
- **Control mode:** Voltage, Current and Power (V-V²-I-I²-VxI) or external feedback
- **Communication:** RS485 port RTU Modbus® Protocol
- **USB:** Integrated port for configuration in safety mode (no load and auxiliary voltage needed). Unit powered through USB
- **Approvals:** Compliant with CE
- **Dual Current Limit:** For peak or RMS value

Attention

- Phase Angle available only on 1PH units
- Delayed Triggering available only on 1PH units
- For three-phase solutions (3PH) with Phase Angle use **REVEX PA** (pag 22)

Options

- All options are shown below with the relevant model code
- HB Alarm to diagnose partial or total load failure and thyristor short circuit

REVEX 3PH 30÷210A / 480÷600V

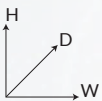

SR10
H 121 x W 108 x D 185 - 1,76 kg
30÷40A



SR25
H 165 x W 116 x D 183 - 2,35 kg
60÷90A



SR17
H 273 x W 279 x D 170 - 10,6 kg
120÷210A

| | | | | | | | | | | | | | | | | |
|-------------------|---|---|---|---|---|---|---|---|---|----|----|----|----|----|----|----|
| REVEX 3PH | 1 | 2 | 3 | 4 | 5 | 6 | 7 | 8 | 9 | 10 | 11 | 12 | 13 | 14 | 15 | 16 |
| ORDER CODE | R | X | 3 | - | - | - | - | - | - | - | - | - | - | - | - | - |

| CURRENT / FUSES | | | 4 | 5 | 6 |
|---|------|-------|------|---|---|
| Description | Size | cod | note | | |
| 30A Extrarapid fixed fuses not included | SR10 | 0 3 0 | | | |
| 35A Extrarapid fixed fuses not included | SR10 | 0 3 5 | | | |
| 40A Extrarapid fixed fuses not included | SR10 | 0 4 0 | | | |
| 60A Extrarapid fixed fuses included | SR25 | 0 6 0 | | | |
| 90A Extrarapid fixed fuses included | SR25 | 0 9 0 | | | |
| 120A Extrarapid fixed fuses included | SR17 | 1 2 0 | | | |
| 150A Extrarapid fixed fuses included | SR17 | 1 5 0 | | | |
| 180A Extrarapid fixed fuses included | SR17 | 1 8 0 | | | |
| 210A Extrarapid fixed fuses included | SR17 | 2 1 0 | | | |

| MAX VOLTAGE | | | 7 |
|-------------|-----|------|---|
| Description | cod | note | |
| 480V | 4 | | |
| 600V | 6 | | |

| MAIN SUPPLY VOLTAGE | | | 8 |
|---------------------|-----|------|---|
| Description | cod | note | |
| 24Vdc | 4 | | |

| INPUT | | | 9 |
|-------------|-----|------|---|
| Description | cod | note | |
| SSR | S | | |
| 0:20mA | B | | |
| 4:20mA | A | | |
| 0:10V | V | | |
| 10KPot | K | | |

| FIRING | START OPTION | 10 | |
|---------------|---------------|-----|------|
| Description | Description | cod | note |
| Burst Firing | No Soft Start | B | |
| Zero Crossing | No Soft Start | Z | |

| CONTROL MODE | | | 11 |
|----------------------------------|-----|------|----|
| Description | cod | note | |
| Open Loop | 0 | | |
| Voltage | U | | |
| Voltage Square (V ²) | Q | | |
| Current | I | | |
| Current Square (I ²) | A | | |
| Power Vxl | W | | |
| External Feedback | X | | |

| OPTION | | | 12 |
|------------------------|-----|------|----|
| Description | cod | note | |
| Option code: see table | ... | | |

| FAN VOLTAGE | | | 13 |
|----------------|-----|------|----|
| Description | cod | note | |
| No fan <60A | 0 | | |
| Fan 24Vdc ≥60A | 3 | | |

| APPROVALS | | | 14 |
|------------------------|-----|------|----|
| Description | cod | note | |
| CE for European market | 0 | | |

| LOAD TYPE | | | 15 |
|--|-----|------|----|
| Description | cod | note | |
| Normal resistive load with 3 phase star connection with neutral | 0 | | |
| Normal resistive load with 3 phase delta or star connection | 1 | | |
| IRSW infrared short wave with 3 phase star connection with neutral | 2 | | |
| IRSW infrared short wave with 3 phase delta or star connection | 3 | | |

| VERSION | | | 16 |
|---|-----|------|----|
| Description | cod | note | |
| Standard Version - N°1 Modbus® RTU std. 30-40A / 120-210A | 0 | | |
| 60A-90A only: Version from 2021 (compact unit) N°1 Modbus® RTU std. | 1 | | |

Option Code (digit 12)

| REVEX 3PH | Heater Break | Display | Cod (digit 12) |
|------------|--------------|---------|----------------|
| 30A - 40A | Y | Y | 0 |
| | Y | N | 2 |
| 60A - 280A | N | N | 3 |
| | N | Y | 5 |
| | N | N | 7 |

| REVEX 3PH | Heater Break | Fuse | Display | Cod (digit 12) |
|------------|--------------|------|---------|----------------|
| 30A - 40A | Y | Y | Y | 0 |
| | Y | Y | N | 1 |
| 60A - 280A | Y | N | N | 2 |
| | N | N | N | 3 |
| | Y | N | Y | 4 |
| | N | N | Y | 5 |
| | N | Y | Y | 6 |
| N | Y | N | 7 | |

N Option you want remove

Y It serves my project

REVEX PA

Technical Specification

- **Load type:** Normal resistance, infrared short, medium and long waveform
- **Input:** 4:20mA, 0:10V, SSR, with Modbus® RTU standard
- **Firing:** Burst Firing, Phase Angle, Delayed Triggering, Zero Crossing
- **Display:** Oled display always present
- **Control mode:** Voltage, Current and Power (V-V²-I-I²-VxI) or external feedback
- **Communication:** RS485 port RTU Modbus® Protocol
- **USB:** Integrated port for configuration in safety mode (no load and auxiliary voltage needed). Unit powered through USB
- **Approvals:** Compliant with CE
- **Dual Current Limit:** For peak or RMS value

Attention

- For three-phase solutions (3PH) with Phase Angle

Options

- All options are shown below with the relevant model code
- HB Alarm to diagnose partial or total load failure and thyristor short circuit

REVEX PA 35÷90A / 480÷600V

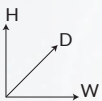

SR25

H 165 x W 116 x D 183 - 2,35 kg
35÷90A

| REVEX PA | 1 | 2 | 3 | 4 | 5 | 6 | 7 | 8 | 9 | 10 | 11 | 12 | 13 | 14 | 15 | 16 |
|-------------------|---|---|---|---|---|---|---|---|---|----|----|----|----|----|----|----|
| ORDER CODE | R | X | P | - | - | - | - | - | - | - | - | - | - | - | - | - |

| CURRENT / FUSES | | | 4 | 5 | 6 |
|-------------------------------------|------|-------|------|---|---|
| Description | Size | cod | note | | |
| 35A Extrarapid fixed fuses included | SR25 | 0 3 5 | | | |
| 50A Extrarapid fixed fuses included | SR25 | 0 5 0 | | | |
| 75A Extrarapid fixed fuses included | SR25 | 0 7 5 | | | |
| 90A Extrarapid fixed fuses included | SR25 | 0 9 0 | | | |

| MAX VOLTAGE | | | 7 |
|-------------|-----|------|---|
| Description | cod | note | |
| 480V | 4 | | |
| 600V | 6 | | |

| MAIN SUPPLY VOLTAGE | | | 8 |
|---------------------|-----|------|---|
| Description | cod | note | |
| 24Vdc | 4 | | |

| INPUT | | | 9 |
|-------------|-----|------|---|
| Description | cod | note | |
| SSR | S | | |
| 0:20mA | B | | |
| 4:20mA | A | | |
| 0:10V | V | | |
| 10KPot | K | | |

| FIRING | START OPTION | 10 |
|--------------------|-------------------|-----|
| Description | Description | cod |
| Burst Firing | No Soft Start | B |
| | Linear Soft Start | J |
| Phase Angle | No Soft Start | P |
| | Linear Soft Start | E |
| Delayed Triggering | No Soft Start | D |
| | Linear Soft Start | T |
| Zero Crossing | No Soft Start | Z |
| | Linear Soft Start | R |

Note 1: This configuration is possible only with Delayed Triggering or Phase Angle Firing.

Note 2: This configuration is possible only with Phase Angle Firing

| CONTROL MODE | | 11 |
|----------------------------------|-----|------|
| Description | cod | note |
| Open Loop | 0 | |
| Voltage | U | |
| Voltage Square (V ²) | Q | |
| Current | I | |
| Current Square (I ²) | A | |
| Power Vxl | W | |
| External Feedback | X | |

| OPTION | | 12 |
|------------------------|-----|------|
| Description | cod | note |
| Option code: see table | ... | |

| FAN VOLTAGE | | 13 |
|-------------|-----|------|
| Description | cod | note |
| Fan 24Vdc | 3 | |

| APPROVALS | | 14 |
|------------------------|-----|------|
| Description | cod | note |
| CE for European market | 0 | |

| LOAD TYPE | | 15 |
|--|-----|------|
| Description | cod | note |
| Normal resistance | 0 | |
| IRSW infrared short wave | 1 | |
| MoSi2 heaters | 2 | 2 |
| SiC heaters | 3 | |
| Transformer coupled with normal resistance | 4 | 1 |
| Transformer coupled with MoSi2 heaters | 5 | 1 |
| Transformer coupled with SiC heaters | 6 | 1 |
| Transformer coupled with UV lamp | 7 | 1 |

| VERSION | | 16 |
|----------------------|-----|------|
| Description | cod | note |
| N°1 Modbus® RTU std. | 0 | |

Option Code (digit 12)

| REVEX PA | Current Limit | Heater Break | Cod (digit 12) |
|-----------|---------------|--------------|----------------|
| 35A - 90A | Y | Y | 2 |
| | Y | N | 3 |
| | N | N | 4 |
| | N | Y | D |

N Option you want remove

Y It serves my project

REVO C

Integrated
Fieldbus

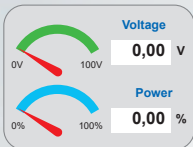

Configurator
software

TIA PORTAL
V16

SIEMENS

Libraries



Main features

Universal power controller with advanced microprocessor, configurable via software.

- **Wide range of communication protocols and fieldbuses available:**
Modbus® RTU, Profibus® DP, Profinet® IO, Modbus® TCP
- Single-phase or three-phase load control with 1-2-3PH
- Voltage range 480÷600÷690V
- **100 kA** Short Circuit Current (SCCR) up to 600V
- Extrarapid fuse and integrated sectional fuse holder up to 40A
- Extrarapid fixed fuses from 60A to 2100A
- Input signals selectable from PC or OLED display
- Standard firing mode available: Half Cycle, Single Cycle, Burst Firing, Delayed Triggering, Phase Angle and Soft Start
- All types of firing mode and control mode available
- **CE** and **cUL** approvals
- **Guided configuration via free software**, available on www.cdautomation.com
- Optional **Bluetooth connection** for communication and control of the unit via APP
- Free CD Automation **APP** for Android and IOS, for unit control with Bluetooth
- Siemens **TIA Portal Libraries** for data exchange with our products (from V16)

Load type

Resistive / Inductive / Infrared lamp short wave (IRSW) and fast medium wave (IRMW) / Molybdenum Disilicide elements (MoSi2) / Silicon Carbide elements (SiC)

Cannot be used for capacitive loading. For information contact our technical department

Industrial applications

- Petrolchemicals
- Platform for oil extraction
- Conventional power generator
- Chemicals and pharmaceuticals
- Renewable Energies
- Autoclaves
- Electric furnaces
- Galvanic process
- Glass industry
- Polysilicon
- Chemical
- Plastic machinery
- Packing machinery
- Automobile
- Paint drying
- UV drying
- Car internal fitting

REVO C - FEATURES

| | Description | Revo C 1PH | | Revo C 2PH | | Revo C 3PH | |
|---------------|--|-------------|------|-------------|------|-------------|------|
| | CODE | RC1 | | RC2 | | RC3 | |
| Load type | Max voltage 480V | ● | | ● | | ● | |
| | Max voltage 600V | ● | | ● | | ● | |
| | Max voltage 690V | ● | | ● | | ● | |
| | Single phase | ● | | | | | |
| | 3 phase load star no neutral or delta | | | ● | | ● | |
| | 3 phase load star with neutral | | | | | ● | |
| | 3 phase load open delta | ●(1) | | | | | |
| Input | SSR 4:30VDC | ● | | ● | | ● | |
| | 4:20 mA | ● | | ● | | ● | |
| | 0:10 Vdc | ● | | ● | | ● | |
| | Potentiometer | ● | | ● | | ● | |
| Firing | Single Cycle | ● | | | | | |
| | Half Cycle | ● | | | | | |
| | Burst Firing | ● | | ● | | ● | |
| | Phase Angle | ● | | | | ● | |
| | Delayed Triggering | ● | | | | ● | |
| | Zero Crossing | ● | | ● | | ● | |
| Control Mode | Open Loop | ● | | ● | | ● | |
| | V | ● | | ● | | ● | |
| | V ² | ● | | ● | | ● | |
| | I | ● | | ● | | ● | |
| | I ² | ● | | ● | | ● | |
| | Power V x I | ● | | ● | | ● | |
| Options | Current Limit - CL | ○ | | | | ○ | |
| | Heater Break Alarm + SCR Short Circuit | ○ | | ○ | | ○ | |
| | Logging | ○ | | ○ | | ○ | |
| | Totalizer | ○ | | ○ | | ○ | |
| Communication | Bluetooth | ○ | | ○ | | ○ | |
| | Modbus® RTU | ● | | ● | | ● | |
| | Profibus® DP + 1 Modbus® RTU | ○ | | ○ | | ○ | |
| | 2 Profinet® IO + 1 Modbus® RTU | ○ | | ○ | | ○ | |
| | 2 Modbus® TCP + 1 Modbus® RTU | ○ | | ○ | | ○ | |
| Current | Current | SIZE | | SIZE | | SIZE | |
| | | 600V Max | 690V | 600V Max | 690V | 600V Max | 690V |
| | 30 | SR9 | | SR10 | | SR11 | |
| | 35 | SR9 | | SR10 | | SR11 | |
| | 40 | SR9 | | SR10 | | SR11 | |
| | 60 | SR12 | S11 | SR13 | S11 | SR14 | S11 |
| | 90 | SR15 | S11 | SR16 | S11 | SR17 | S11 |
| | 120 | SR15 | S11 | SR16 | S13 | SR17 | S13 |
| | 150 | SR15 | S11 | SR16 | S13 | SR17 | S13 |
| | 180 | SR15 | S11 | SR16 | S13 | SR17 | S13 |
| | 210 | SR15 | S11 | SR16 | S13 | SR17 | S13 |
| | 300 | S12 | | S14 | S14 | S14 | S14 |
| | 400 | S12 | S12 | S14 | S14 | S14 | S14 |
| | 450 | | | S14 | S14 | S14 | S14 |
| | 500 | S12 | S12 | S14 | S14 | S14 | S14 |
| | 600 | S12 | S12 | S14 | S14 | S17* | S17 |
| | 700 | S12 | S12 | S14 | S14 | S17* | S17 |
| | 800 | S15* | S15 | S16* | S16 | S17* | S17 |
| | 1100 | SR18* | SR18 | SR19* | SR19 | SR20* | SR20 |
| | 1400 | SR21* | SR21 | SR22* | SR22 | SR23* | SR23 |
| | 1600 | SR21* | SR21 | SR22* | SR22 | SR23* | SR23 |
| | 1800 | SR21* | SR21 | SR22* | SR22 | SR23* | SR23 |
| | 2100 | SR21* | SR21 | SR22* | SR22 | SR23* | SR23 |

● Standard ○ Option ■ CE standard + cUL® option / *UL approval option ■ CE Only - **Note 1:** Use n° 3 Revo-C 1PH

REVO C 1PH

Technical Specification

- **Load type:** Normal Resistance, Infrared Short, Medium and Long, Transformer Primary, Cold resistance, SiC and MoSi2 heaters
- **Input:** 4÷20mA, 0÷10V, SSR, with Modbus® RTU standard; and different Field Bus listed in the Order Code
- **Firing:** Half Cycle, Single Cycle, Burst Firing, Delayed Triggering, Phase Angle with or without Soft Start
- **Control mode:** Can be configured with feedback on Current, Voltage, Power or Open Loop mode
- **Communication:** **RS485 port, Modbus® RTU protocol and optional integrated fieldbus: Profibus® DP, Profinet® IO, Modbus® TCP, Ethernet® IP**
- **USB:** Integrated port for configuration in safety mode (no load and auxiliary voltage needed). Unit powered through USB
- **100kA:** Short Circuit Current rating (SCCR) up to 600V
- **Approvals:** Compliant with CE, cUL (option) up to 700A, UL (option) from 800A to 2100A
- **Dual Current Limit:** For peak and RMS value

Options

All options are shown in the table on page 34 with the relevant code

- Energy totalizer
- Data logging
- Bluetooth
- Heater Break (HB) Alarm to diagnose partial or Total Load Failure and Thyristor Short Circuit
- Over-temperature alarm
- Available on some size: Fuse alarm signal (FUMS) and 2° thermal switch

REVO C 1PH 30A-800A / 480V-600V

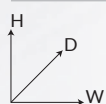

SR9
H 121xW 72 xD 185
1,15 kg
30-40A



SR12
H 269 xW 93 xD 170
3,4kg
60A



SR15
H 273xW 93xD 170
3,6 kg
90-210A



S12
H 520xW 137xD 270
15 kg
300-700A



S15
H 560xW 137 x D 270
17,2 kg
800A

REVO C 1PH 60A-800A / 690V



S11
H 440xW 137 xD 270
10,5 kg
60-210A



S12
H 520xW 137 xD 270
15 kg
400-700A



S15
H 560xW 137xD 270
17,2 kg
800A

REVO C 1PH

| | | | | | | | | | | | | | | | | | |
|-------------------|---|---|---|---|---|---|---|---|---|---|----|----|----|----|----|----|----|
| | 1 | 2 | 3 | 4 | 5 | 6 | | 7 | 8 | 9 | 10 | 11 | 12 | 13 | 14 | 15 | 16 |
| ORDER CODE | R | C | 1 | - | - | - | - | - | - | - | - | - | - | - | - | - | - |

| CURRENT / FUSES | | | 4 | 5 | 6 | |
|--|---------------|-----------|-------|------|---|---|
| Description | Size 480-600V | Size 690V | cod | note | | |
| 30A Extrarapid fuse + fuse holder included | SR9 | -- | 0 3 0 | | | |
| 35A Extrarapid fuse + fuse holder included | SR9 | -- | 0 3 5 | | | |
| 40A Extrarapid fuse + fuse holder included | SR9 | -- | 0 4 0 | | | |
| 60A Extrarapid fixed fuses included | SR12 | S11 | 0 6 0 | | | |
| 90A Extrarapid fixed fuses included | SR15 | S11 | 0 9 0 | | | |
| 120A Extrarapid fixed fuses included | SR15 | S11 | 1 2 0 | | | |
| 150A Extrarapid fixed fuses included | SR15 | S11 | 1 5 0 | | | |
| 180A Extrarapid fixed fuses included | SR15 | S11 | 1 8 0 | | | |
| 210A Extrarapid fixed fuses included | SR15 | S11 | 2 1 0 | | | |
| 300A Extrarapid fixed fuses included | S12 | -- | 3 0 0 | | | |
| 400A Extrarapid fixed fuses included | S12 | S12 | 4 0 0 | | | |
| 500A Extrarapid fixed fuses included | S12 | S12 | 5 0 0 | | | |
| 600A Extrarapid fixed fuses included | S12 | S12 | 6 0 0 | | | |
| 700A Extrarapid fixed fuses included | S12 | S12 | 7 0 0 | | | |
| 800A Extrarapid fixed fuses included | S15 | S15 | 8 0 0 | | | 5 |

| MAX VOLTAGE | 7 | |
|-------------|-----|------|
| Description | cod | note |
| 480V | 4 | |
| 600V | 6 | |
| 690V | 7 | 1, 2 |

| MAIN SUPPLY VOLTAGE | AUX VOLTAGE RANGE | 8 | |
|---------------------|-------------------|-----|------|
| | V range | cod | note |
| 100/120Vac | 90÷135Vac | 1 | 3 |
| 200/208/230/240Vac | 180÷265Vac | 2 | 3 |
| 277Vac | 238÷330Vac | 3 | 3 |
| 380/415/480Vac | 342÷528Vac | 5 | 3 |
| 600Vac | 540÷759Vac | 6 | 3 |
| 690Vac | 540÷759Vac | 7 | 3 |

| INPUT | 9 | |
|-------------|-----|------|
| Description | cod | note |
| SSR | S | |
| 0:20mA | B | |
| 4:20mA | A | |
| 0:10V | V | |
| 10KPot | K | |
| DPU | D | |

| FIRING | START OPTION | 10 | |
|--------------------|---------------------------------|-----|------|
| Description | Description | cod | note |
| Single Cycle | No Soft Start | C | |
| | Linear Soft Start | S | |
| Half Cycle | No Soft Start | H | |
| | Linear Soft Start | L | |
| | Soft Start for short Infr. Lamp | I | |
| Burst Firing | No Soft Start | B | |
| | Linear Soft Start | J | |
| Phase Angle | No Soft Start | P | |
| | Linear Soft Start | E | |
| Delayed Triggering | No Soft Start | D | |
| | Linear Soft Start | T | |
| Zero Crossing | No Soft Start | Z | |
| | Linear Soft Start | R | |

| CONTROL MODE | 11 | |
|----------------|-----|------|
| Description | cod | note |
| Open Loop | 0 | |
| Voltage | U | |
| Voltage Square | Q | |
| Current | I | |
| Current Square | A | |
| Power VxI | W | |

| OPTION | 12 | |
|---------------------------------|-----|------|
| Description | cod | note |
| No option | 0 | |
| Option Code - See table page 34 | ... | |

| FAN VOLTAGE | 13 | |
|--|-----|------|
| Description | cod | note |
| No fan <90A 480V/600V | 0 | |
| Fan 115Vac ≥90A 480V/600V - ≥60A 690V | 1 | |
| Fan 230Vac ≥90A 480V/600V - ≥60A 690V Standard | 2 | |
| Fan 24Vdc ≥90A 480V/600V - ≥60A 690V | 3 | |

| APPROVALS | 14 | |
|------------------------|-----|------|
| Description | cod | note |
| CE for European market | 0 | |
| CE + cUL | L | |

| LOAD TYPE | 15 | |
|---|-----|------|
| Description | cod | note |
| 1 PH Normal resistance | 0 | |
| 1 PH IRSW infrared short wave | 1 | |
| 1 PH MoSi2 heaters | 2 | 7 |
| 1 PH SiC Heaters | 3 | |
| 1 PH Transformer coupled with normal resistance | 4 | 6 |
| 1 PH Transformer coupled with MoSi2 heaters | 5 | 6 |
| 1 PH Transformer coupled with SiC heaters | 6 | 6 |
| 1 PH Transformer coupled with UV lamp | 7 | 6 |

| COMMUNICATION AND RETRANSMISSION | | 16 | |
|--|-----------------------|-----|------|
| Description | Description | cod | note |
| N°1 Modbus® RTU | No Retransmission | 0 | |
| | Retransmission 4:20mA | 1 | |
| | Retransmission 0:10V | 2 | |
| N°2 Modbus® RTU | No Retransmission | 3 | 4 |
| | Retransmission 4:20mA | 4 | 4 |
| | Retransmission 0:10V | 5 | 4 |
| N°1 Profibus® DP (becoming obsolete) + N°1 Modbus® RTU | No Retransmission | 6 | 4 |
| | Retransmission 4:20mA | 7 | 4 |
| | Retransmission 0:10V | 8 | 4 |
| N°1 Profinet® IO + N°1 Modbus® RTU | No Retransmission | 9 | 4 |
| | Retransmission 4:20mA | A | 4 |
| | Retransmission 0:10V | B | 4 |
| N°1 Modbus® TCP + N°1 Modbus® RTU | No Retransmission | C | 4 |
| | Retransmission 4:20mA | D | 4 |
| | Retransmission 0:10V | E | 4 |
| N°1 Ethernet IP + N°1 Modbus® RTU | No Retransmission | F | 4 |
| | Retransmission 4:20mA | G | 4 |
| | Retransmission 0:10V | H | 4 |
| N°1 EtherCAT + N°1 Modbus® RTU | No Retransmission | I | 4 |
| | Retransmission 4:20mA | L | 4 |
| | Retransmission 0:10V | M | 4 |

- Note 1:** No cUL/UL approved
- Note 2:** Available on unit ≥60A
- Note 3:** Main Supply Voltage has to be included in Auxiliary Voltage range
- Note 4:** 24Vdc Backup Power for User Interface and Communications included
- Note 5:** Only CE and UL approved, not cUL
- Note 6:** This configuration is possible only with Delayed Triggering or Phase Angle Firing
- Note 7:** This configuration is possible only with Phase Angle Firing

REVO C 2PH

Technical Specification

- **Load type:** Normal Resistance, Infrared Short, Medium and Long waveform
- **Input:** 4÷20mA, 0÷10V, SSR, with Modbus® RTU standard; and different Field Bus listed in the Order Code
- **Firing:** Burst Firing, Zero Crossing
- **Control mode:** Can be configured with feedback on Current, Voltage, Power or Open Loop mode
- **Communication:** **RS485 port, Modbus® RTU protocol and optional integrated fieldbus:**
Profibus® DP, Profinet® IO, Modbus® TCP, Ethernet® IP
- **USB:** Integrated port for configuration in safety mode (no load and auxiliary voltage needed). Unit powered through USB
- **100kA:** Short Circuit Current rating (SCCR) up to 600V
- **Approvals:** Compliant with CE, cUL (option) up to 700A, UL (option) from 800A to 2100A
- **Integrated pass-through phase:** 480V-600V: all sizes S14 / 690V: all sizes S11, S13, S14

Options

All options are shown in the table on page 34 with the relevant code

- Energy totalizer
- Data logging
- Bluetooth
- Heater Break (HB) Alarm to diagnose partial or Total Load Failure and Thyristor Short Circuit
- Over-temperature alarm
- Available on some size: Fuse alarm signal (FUMS) and 2° thermal switch

REVO C 2PH 30÷800A / 480÷600V

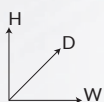

SR10
H 121xW 108xD 185
1,76 kg
30÷40A



SR13
H 269xW 186xD 170
6,8kg
60A



SR16
H 273xW 186xD 170
7,0 kg
90÷210A



S14
H 520xW 262xD 270
22 kg
300÷700A



S16
H 560xW 275xD 270
34,4 kg
800A

REVO C 2PH 60÷800A / 690V



S11
H 440xW 137xD 270
10,5 kg
60÷90A



S13
H 440xW 262xD 270
18 kg
120÷210A



S14
H 520xW 262xD 270
22 kg
300÷700A



S16
H 560xW 275xD 270
34,4 kg
800A

| | | | | | | | | | | | | | | | | |
|------------|---|---|---|---|---|---|---|---|---|----|----|----|----|----|----|----|
| REVO C 2PH | 1 | 2 | 3 | 4 | 5 | 6 | 7 | 8 | 9 | 10 | 11 | 12 | 13 | 14 | 15 | 16 |
| ORDER CODE | R | C | 2 | - | - | - | - | - | - | - | - | - | - | - | - | - |

| CURRENT / FUSES | | | 4 | 5 | 6 | |
|--|---------------|-----------|-------|------|---|--|
| Description | Size 480-600V | Size 690V | cod | note | | |
| 30A Extrarapid fuse + fuse holder included | SR10 | -- | 0 3 0 | | | |
| 35A Extrarapid fuse + fuse holder included | SR10 | -- | 0 3 5 | | | |
| 40A Extrarapid fuse + fuse holder included | SR10 | -- | 0 4 0 | | | |
| 60A Extrarapid fixed fuses included | SR13 | S11 | 0 6 0 | | | |
| 90A Extrarapid fixed fuses included | SR16 | S11 | 0 9 0 | | | |
| 120A Extrarapid fixed fuses included | SR16 | S13 | 1 2 0 | | | |
| 150A Extrarapid fixed fuses included | SR16 | S13 | 1 5 0 | | | |
| 180A Extrarapid fixed fuses included | SR16 | S13 | 1 8 0 | | | |
| 210A Extrarapid fixed fuses included | SR16 | S13 | 2 1 0 | | | |
| 300A Extrarapid fixed fuses included | S14 | S14 | 3 0 0 | | | |
| 400A Extrarapid fixed fuses included | S14 | S14 | 4 0 0 | | | |
| 450A Extrarapid fixed fuses included | S14 | S14 | 4 5 0 | | | |
| 500A Extrarapid fixed fuses included | S14 | S14 | 5 0 0 | | | |
| 600A Extrarapid fixed fuses included | S14 | S14 | 6 0 0 | | | |
| 700A Extrarapid fixed fuses included | S14 | S14 | 7 0 0 | | | |
| 800A Extrarapid fixed fuses included | S16 | S16 | 8 0 0 | 5 | | |

| MAX VOLTAGE | | 7 | |
|-------------|-----|------|--|
| Description | cod | note | |
| 480V | 4 | | |
| 600V | 6 | | |
| 690V | 7 | 1,2 | |

| MAIN SUPPLY VOLTAGE | AUX VOLTAGE RANGE | 8 | |
|---------------------|-------------------|-----|------|
| | V range | cod | note |
| 100/120Vac | 90÷135Vac | 1 | 3 |
| 200/208/230/240Vac | 180÷265Vac | 2 | 3 |
| 277Vac | 238÷330Vac | 3 | 3 |
| 380/415/480Vac | 342÷528Vac | 5 | 3 |
| 600Vac | 540÷759Vac | 6 | 3 |
| 690Vac | 540÷759Vac | 7 | 3 |

| INPUT | | 9 | |
|-------------|-----|------|--|
| Description | cod | note | |
| SSR | S | | |
| 0:20mA | B | | |
| 4:20mA | A | | |
| 0:10V | V | | |
| 10KPot | K | | |
| DPU | D | | |

| FIRING | | START OPTION | | 10 | |
|---------------|---------------|--------------|------|----|--|
| Description | Description | cod | note | | |
| Burst Firing | No Soft Start | B | | | |
| Zero Crossing | No Soft Start | Z | | | |

| CONTROL MODE | | 11 | |
|----------------|-----|------|--|
| Description | cod | note | |
| Open Loop | 0 | | |
| Voltage | U | | |
| Voltage Square | Q | | |
| Current | I | | |
| Current Square | A | | |
| Power Vxl | W | | |

| OPTION | | 12 | |
|---------------------------------|-----|------|--|
| Description | cod | note | |
| No option | 0 | | |
| Option Code - See table page 34 | ... | | |

| FAN VOLTAGE | | 13 | |
|--|-----|------|--|
| Description | cod | note | |
| No fan <90A 480V/600V | 0 | | |
| Fan 115Vac ≥90A 480V/600V - ≥60A 690V | 1 | | |
| Fan 230Vac ≥90A 480V/600V - ≥60A 690V Standard | 2 | | |
| Fan 24Vdc ≥90A 480V/600V - ≥60A 690V | 3 | | |

| APPROVALS | | 14 | |
|------------------------|-----|------|--|
| Description | cod | note | |
| CE for European market | 0 | | |
| CE + cUL | L | | |

| LOAD TYPE | | 15 | |
|--|-----|------|--|
| Description | cod | note | |
| Normal resistive load with 3 phase star without neutral connection | 0 | | |
| Normal resistive load with 3 Phase delta connection | 1 | | |
| IRSW infrared short wave with 3 phase star connection | 2 | | |
| IRSW infrared short wave with 3 phase delta connection | 3 | | |

| COMMUNICATION AND RETRANSMISSION | | | | 16 | |
|--|-----------------------|-----|------|----|--|
| Description | Description | cod | note | | |
| N°1 Modbus® RTU | No Retransmission | 0 | | | |
| | Retransmission 4:20mA | 1 | | | |
| | Retransmission 0:10V | 2 | | | |
| N°2 Modbus® RTU | No Retransmission | 3 | 4 | | |
| | Retransmission 4:20mA | 4 | 4 | | |
| | Retransmission 0:10V | 5 | 4 | | |
| N°1 Profibus® DP (becoming obsolete) + N°1 Modbus® RTU | No Retransmission | 6 | 4 | | |
| | Retransmission 4:20mA | 7 | 4 | | |
| | Retransmission 0:10V | 8 | 4 | | |
| N°1 Profinet® IO + N°1 Modbus® RTU | No Retransmission | 9 | 4 | | |
| | Retransmission 4:20mA | A | 4 | | |
| | Retransmission 0:10V | B | 4 | | |
| N°1 Modbus® TCP + N°1 Modbus® RTU | No Retransmission | C | 4 | | |
| | Retransmission 4:20mA | D | 4 | | |
| | Retransmission 0:10V | E | 4 | | |
| N°1 Ethernet IP + N°1 Modbus® RTU | No Retransmission | F | 4 | | |
| | Retransmission 4:20mA | G | 4 | | |
| | Retransmission 0:10V | H | 4 | | |
| N°1 EtherCAT + N°1 Modbus® RTU | No Retransmission | I | 4 | | |
| | Retransmission 4:20mA | L | 4 | | |
| | Retransmission 0:10V | M | 4 | | |

Note 1: No cUL/UL approved

Note 2: Available on unit ≥60A

Note 3: Main Supply Voltage has to be included in Auxiliary Voltage range, only for sizes from SR10 to SR16

Note 4: 24Vdc Backup Power for User Interface and Communications included

Note 5: Only CE and UL approved, not cUL

REVO C 3PH

Technical Specification

- **Load type:** Normal Resistance, Infrared Short, Medium and Long, Transformer Primary, Cold resistance, SiC and MoSi2 heaters
- **Input:** 4÷20mA, 0÷10V, SSR, with Modbus® RTU standard; and different Field Bus listed in the Order Code
- **Firing:** Half Cycle, Single Cycle, Burst Firing, Delayed Triggering, Phase Angle with or without Soft Start
- **Control mode:** Can be configured with feedback on Current, Voltage, Power or Open Loop mode
- **Communication:** **RS485 port, Modbus® RTU protocol and optional integrated fieldbus: Profibus® DP, Profinet® IO, Modbus® TCP, Ethernet® IP**
- **USB:** Integrated port for configuration in safety mode (no load and auxiliary voltage needed). Unit powered through USB
- **100kA:** Short Circuit Current rating (SCCR) up to 600V
- **Approvals:** Compliant with CE, cUL (option) up to 500A, UL (option) from 600A to 2100A
- **Dual Current Limit:** For peak and RMS value

Options

All options are shown in the table on page 34 with the relevant code

- Energy totalizer
- Data logging
- Bluetooth
- Heater Break (HB) Alarm to diagnose partial or Total Load Failure and Thyristor Short Circuit
- Over-temperature alarm
- Available on some size: Fuse alarm signal (FUMS) and 2° thermal switch

REVO C 3PH 30÷800A / 480÷600V

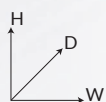

SR11

H 121xW 144xD 185
2,4 kg
30÷40A



SR14

H 269xW 279xD 170
10,2kg
60A



SR17

H 273xW 279xD 170
10,6 kg
90÷210A



S14

H 520xW 262xD 270
22 kg
300÷500A



S17

H 560xW 411xD 270
51,6 kg
600÷800A

REVO C 3PH 60÷800A / 690V



S11

H 440xW 137xD 270
10,5 kg
60÷90A



S13

H 440xW 262xD 270
18 kg
120÷210A



S14

H 520xW 262xD 270
22 kg
300÷500A



S17

H 560xW 411xD 270
51,6 kg
600÷800A

| | | | | | | | | | | | | | | | | |
|------------|---|---|---|---|---|---|---|---|---|----|----|----|----|----|----|----|
| REVO C 3PH | 1 | 2 | 3 | 4 | 5 | 6 | 7 | 8 | 9 | 10 | 11 | 12 | 13 | 14 | 15 | 16 |
| ORDER CODE | R | C | 3 | - | - | - | - | - | - | - | - | - | - | - | - | - |

| CURRENT / FUSES | | | 4 | 5 | 6 | |
|--|---------------|-----------|-------|------|---|--|
| Description | Size 480-600V | Size 690V | cod | note | | |
| 30A Extrarapid fuse + fuse holder included | SR11 | -- | 0 3 0 | 2 | | |
| 35A Extrarapid fuse + fuse holder included | SR11 | -- | 0 3 5 | 2 | | |
| 40A Extrarapid fuse + fuse holder included | SR11 | -- | 0 4 0 | 2 | | |
| 60A Extrarapid fixed fuses included | SR14 | S11 | 0 6 0 | | | |
| 90A Extrarapid fixed fuses included | SR17 | S11 | 0 9 0 | | | |
| 120A Extrarapid fixed fuses included | SR17 | S13 | 1 2 0 | | | |
| 150A Extrarapid fixed fuses included | SR17 | S13 | 1 5 0 | | | |
| 180A Extrarapid fixed fuses included | SR17 | S13 | 1 8 0 | | | |
| 210A Extrarapid fixed fuses included | SR17 | S13 | 2 1 0 | | | |
| 300A Extrarapid fixed fuses included | S14 | S14 | 3 0 0 | | | |
| 400A Extrarapid fixed fuses included | S14 | S14 | 4 0 0 | | | |
| 450A Extrarapid fixed fuses included | S14 | S14 | 4 5 0 | | | |
| 500A Extrarapid fixed fuses included | S14 | S14 | 5 0 0 | | | |
| 600A Extrarapid fixed fuses included | S17 | S17 | 6 0 0 | 5 | | |
| 700A Extrarapid fixed fuses included | S17 | S17 | 7 0 0 | 5 | | |
| 800A Extrarapid fixed fuses included | S17 | S17 | 8 0 0 | 5 | | |

| MAX VOLTAGE | 7 | |
|-------------|-----|------|
| Description | cod | note |
| 480V | 4 | |
| 600V | 6 | |
| 690V | 7 | 1 |

| MAIN SUPPLY VOLTAGE | AUX VOLTAGE RANGE | 8 | |
|---------------------|-------------------|-----|------|
| | V range | cod | note |
| 100/120Vac | 90÷135Vac | 1 | 3 |
| 200/208/230/240Vac | 180÷265Vac | 2 | 3 |
| 277Vac | 238÷330Vac | 3 | 3 |
| 380/415/480Vac | 342÷528Vac | 5 | 3 |
| 600Vac | 540÷759Vac | 6 | 3 |
| 690Vac | 540÷759Vac | 7 | 3 |

| INPUT | 9 | |
|-------------|-----|------|
| Description | cod | note |
| SSR | S | |
| 0:20mA | B | |
| 4:20mA | A | |
| 0:10V | V | |
| 10KPot | K | |
| DPU | D | |

| FIRING | START OPTION | 10 | |
|--------------------|-------------------|-----|------|
| Description | Description | cod | note |
| Burst Firing | No Soft Start | B | |
| | Linear Soft Start | J | |
| Phase Angle | No Soft Start | P | 2 |
| | Linear Soft Start | E | 2 |
| Delayed Triggering | No Soft Start | D | 2 |
| Zero Crossing | No Soft Start | Z | |
| | Linear Soft Start | R | |

| CONTROL MODE | 11 | |
|----------------|-----|------|
| Description | cod | note |
| Open Loop | 0 | |
| Voltage | U | |
| Voltage Square | Q | |
| Current | I | |
| Current Square | A | |
| Power VxI | W | |

| OPTIONS | 12 | |
|---------------------------------|-----|------|
| Description | cod | note |
| No option | 0 | |
| Option Code - See table page 34 | ... | |

| FAN VOLTAGE | 13 | |
|--|-----|------|
| Description | cod | note |
| No fan <90A 480V/600V | 0 | |
| Fan 115Vac ≥90A 480V/600V - ≥60A 690V | 1 | |
| Fan 230Vac ≥90A 480V/600V - ≥60A 690V Standard | 2 | |
| Fan 24Vdc ≥90A 480V/600V - ≥60A 690V | 3 | |

| APPROVALS | 14 | |
|------------------------|-----|------|
| Description | cod | note |
| CE for European market | 0 | |
| CE + cUL | L | |

| LOAD TYPE | 15 | |
|--|-----|------|
| Description | cod | note |
| Normal resistive with 3 phase star connection with neutral | 0 | |
| Normal resistive with 3 phase delta or star connection | 1 | |
| IRSW infrared short wave with 3 phase star connection with neutral | 2 | |
| IRSW infrared short wave with 3 phase delta or star connection | 3 | |
| 3 phase transformer coupled with normal resistance | 4 | 7 |
| 3 phase transformer coupled with cold resistance | 5 | 7 |

| COMMUNICATION AND RETRANSMISSION | | 16 | |
|--|-----------------------|-----|------|
| Description | Description | cod | note |
| N°1 Modbus® RTU | No Retransmission | 0 | |
| | Retransmission 4:20mA | 1 | |
| | Retransmission 0:10V | 2 | |
| N°2 Modbus® RTU | No Retransmission | 3 | 4 |
| | Retransmission 4:20mA | 4 | 4 |
| | Retransmission 0:10V | 5 | 4 |
| N°1 Profibus® DP (becoming obsolete) + N°1 Modbus® RTU | No Retransmission | 6 | 4 |
| | Retransmission 4:20mA | 7 | 4 |
| | Retransmission 0:10V | 8 | 4 |
| N°1 Profinet® IO + N°1 Modbus® RTU | No Retransmission | 9 | 4 |
| | Retransmission 4:20mA | A | 4 |
| | Retransmission 0:10V | B | 4 |
| N°1 Modbus® TCP + N°1 Modbus® RTU | No Retransmission | C | 4 |
| | Retransmission 4:20mA | D | 4 |
| | Retransmission 0:10V | E | 4 |
| N°1 Ethernet IP + N°1 Modbus® RTU | No Retransmission | F | 4 |
| | Retransmission 4:20mA | G | 4 |
| | Retransmission 0:10V | H | 4 |
| N°1 EtherCAT + N°1 Modbus® RTU | No Retransmission | I | 4 |
| | Retransmission 4:20mA | L | 4 |
| | Retransmission 0:10V | M | 4 |

Note 1: No cUL/UL approved **Note 2:** Phase Angle and Delayed Triggering not available for 30A, 35A, 40A

Note 3: Main Supply Voltage has to be included in Auxiliary Voltage range, only for sizes from SR11 to SR17

Note 4: 24Vdc Backup Power for User Interface and Communications included **Note 5:** Only CE and UL approved, not cUL

Note 6: Available on unit ≥60A **Note 7:** This configuration is possible only with Phase Angle firing

REVO C Extended Version

Technical Specification

- **Load type:** Normal Resistance, Infrared Short, Medium and Long, Transformer Primary, Cold resistance, SiC and MoSi2 heaters
- **Input:** 4÷20mA, 0÷10V, SSR, with Modbus® RTU standard; and different Field Bus listed in the Order Code
- **Firing:** Half Cycle, Single Cycle, Burst Firing, Delayed Triggering, Phase Angle with or without Soft Start
- **Control mode:** Can be configured with feedback on Current, Voltage, Power or Open Loop mode
- **Communication:** **RS485 port, Modbus® RTU protocol and optional integrated fieldbus: Profibus® DP, Profinet® IO, Modbus® TCP, Ethernet® IP**
- **USB:** Integrated port for configuration in safety mode (no load and auxiliary voltage needed). Unit powered through USB
- **100kA:** Short Circuit Current rating (SCCR) up to 600V
- **Approvals:** Compliant with CE, UL (option)
- **Dual Current Limit:** For peak and RMS value

Options

All options are shown in the table on page 34 with the relevant code

- Energy totalizer
- Data logging
- Bluetooth
- Heater Break (HB) Alarm to diagnose partial or Total Load Failure and Thyristor Short Circuit
- Over-temperature alarm
- Available on some size: Fuse alarm signal (FUMS) and 2° thermal switch
- IP20 protection

REVO C 1-2-3PH 1100÷2100A / 480V-600V-690V

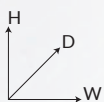

SR18
H 550 x W 329 x D 347 - 27 kg
1100A



SR19
H 550 x W 523 x D 347 - 49 kg
1100A



SR20
H 550 x W 717 x D 347 - 72 kg
1100A

with IP20 protection



SR21
H 730 x W 329 x D 347 - 34 kg
1400-2100A



SR22
H 730 x W 523 x D 347 - 65 kg
1400-2100A



SR23
H 730 x W 717 x D 347 - 98 kg
1400-2100A

without IP20 protection
(D=315 mm)



| ORDER CODE | 1 | 2 | 3 | 4 | 5 | 6 | 7 | 8 | 9 | 10 | 11 | 12 | 13 | 14 | 15 | 16 |
|-------------------|---|---|---|---|---|---|---|---|---|----|----|----|----|----|----|----|
| REVO C 1PH | R | C | 1 | - | - | - | - | - | - | - | - | - | - | - | - | - |
| REVO C 2PH | R | C | 2 | - | - | - | - | - | - | - | - | - | - | - | - | - |
| REVO C 3PH | R | C | 3 | - | - | - | - | - | - | - | - | - | - | - | - | - |

| CURRENT / FUSES | | | 4 | 5 | 6 | | |
|-----------------|---------------------------------|-------------------|------|------|-----|------|---|
| Description | | Size 480-600-690V | | | cod | note | |
| | | 1PH | 2PH | 3PH | | | |
| 1100A | Extrarapid fixed fuses included | SR18 | SR19 | SR20 | 1 | 1 | H |
| 1400A | Extrarapid fixed fuses included | SR21 | SR22 | SR23 | 1 | 4 | H |
| 1600A | Extrarapid fixed fuses included | SR21 | SR22 | SR23 | 1 | 6 | H |
| 1800A | Extrarapid fixed fuses included | SR21 | SR22 | SR23 | 1 | 8 | H |
| 2100A | Extrarapid fixed fuses included | SR21 | SR22 | SR23 | 2 | 1 | H |

| MAX VOLTAGE | | 7 | |
|-------------|--|-----|------|
| Description | | cod | note |
| 480V | | 4 | |
| 600V | | 6 | |
| 690V | | 7 | 1 |

| AUX SUPPLY VOLTAGE | AUX VOLTAGE RANGE | 8 | |
|--------------------|-------------------|-----|------|
| Description | Description | cod | note |
| 100/120Vac | 90÷135Vac | 1 | |
| 200/208/230/240Vac | 180÷265Vac | 2 | |

| INPUT | | 9 | |
|-------------|--|-----|------|
| Description | | cod | note |
| SSR | | S | |
| 0:20mA | | B | |
| 4:20mA | | A | |
| 0:10V | | V | |
| 10KPot | | K | |
| DPU | | D | |

| FIRING | START OPTION | 10 | |
|--------------------|-------------------|-----|------|
| Description | Description | cod | note |
| Burst Firing | No Soft Start | B | |
| | Linear Soft Start | J | 4 |
| Phase Angle | No Soft Start | P | 4 |
| | Linear Soft Start | E | 4 |
| Delayed Triggering | No Soft Start | D | 4 |
| | Linear Soft Start | T | 3 |
| Zero Crossing | No Soft Start | Z | |
| | Linear Soft Start | R | 4 |

| CONTROL MODE | | 11 | |
|----------------|--|-----|------|
| Description | | cod | note |
| Open Loop | | 0 | |
| Voltage | | U | |
| Voltage Square | | Q | |
| Current | | I | |
| Current Square | | A | |
| Power Vxl | | W | |

| OPTION | | 12 | |
|--------------------------------------|--|-----|------|
| Description | | cod | note |
| No option | | 0 | |
| Option Code - See tables pages 34-35 | | ... | |

| FAN VOLTAGE | | 13 | |
|---------------------|--|-----|------|
| Description | | cod | note |
| Fan 115Vac | | 1 | |
| Fan 230Vac Standard | | 2 | |

| APPROVALS | | 14 | |
|--|--|-----|------|
| Description | | cod | note |
| CE for European market - IP00 protection | | 0 | |
| CE for European market - IP20 protection | | 1 | |
| UL + CE - IP00 protection | | 2 | |
| UL + CE - IP20 protection | | L | |

| LOAD TYPE | | 15 | |
|--|--|-----|------|
| Description | | cod | note |
| Normal resistance | | 0 | |
| IRSW infrared short wave | | 1 | |
| MoSi2 heaters | | 2 | 3,5 |
| SiC heaters | | 3 | 3 |
| Transformer coupled with normal resistance | | 4 | 3,4 |
| Transformer coupled with MoSi2 heaters | | 5 | 3,4 |
| Transformer coupled with SiC heaters | | 6 | 3,4 |
| Transformer coupled with UV lamp | | 7 | 3,4 |

| COMMUNICATION AND RETRANSMISSION | | 16 | |
|--|-----------------------|-----|------|
| Description | Description | cod | note |
| N°1 Modbus® RTU | No Retransmission | 0 | |
| | Retransmission 4:20mA | 1 | |
| | Retransmission 0:10V | 2 | |
| N°2 Modbus® RTU | No Retransmission | 3 | 2 |
| | Retransmission 4:20mA | 4 | 2 |
| | Retransmission 0:10V | 5 | 2 |
| N°1 Profibus® DP (becoming obsolete) + N°1 Modbus® RTU | No Retransmission | 6 | 2 |
| | Retransmission 4:20mA | 7 | 2 |
| | Retransmission 0:10V | 8 | 2 |
| N°1 Profinet® IO + N°1 Modbus® RTU | No Retransmission | 9 | 2 |
| | Retransmission 4:20mA | A | 2 |
| | Retransmission 0:10V | B | 2 |
| N°1 Modbus® TCP + N°1 Modbus® RTU | No Retransmission | C | 2 |
| | Retransmission 4:20mA | D | 2 |
| | Retransmission 0:10V | E | 2 |
| N°1 Ethernet IP + N°1 Modbus® RTU | No Retransmission | F | 2 |
| | Retransmission 4:20mA | G | 2 |
| | Retransmission 0:10V | H | 2 |
| N°1 EtherCAT + N°1 Modbus® RTU | No Retransmission | I | 2 |
| | Retransmission 4:20mA | L | 2 |
| | Retransmission 0:10V | M | 2 |

Note 1: No cUL/UL approved

Note 2: 24Vdc Backup Power for User Interface and Communications included

Note 3: Available on 1PH and 3PH only

Note 4: This configuration is possible only with Delayed Triggering or Phase Angle Firing

Note 5: This configuration is possible only with Phase Angle Firing

REVO C Options

Option codes REVO C 1PH (Digit 12)

No option

Option selected (es cod 3: Logging + Totalizer)

| I LIMIT | HB | BLUETOOTH | LOGGING | TOTALIZER | Cod. OPTION | NOTES |
|---------|----|-----------|---------|-----------|-------------|-------|
| | | | | | 0 | |
| | | | | | 1 | |
| | | | | | 2 | |
| | | | | | 3 | |
| | | | | | 4 | |
| | | | | | 5 | |
| | | | | | 6 | |
| | | | | | 7 | |
| | | | | | 8 | |
| | | | | | 9 | |
| | | | | | A | |
| | | | | | B | |
| | | | | | C | |
| | | | | | D | |
| | | | | | E | |
| | | | | | F | |
| | | | | | G | |
| | | | | | H | |
| | | | | | I | |
| | | | | | J | |
| | | | | | K | |
| | | | | | L | |
| | | | | | M | |
| | | | | | N | |
| | | | | | O | |
| | | | | | P | |
| | | | | | Q | |
| | | | | | R | |
| | | | | | S | |
| | | | | | T | |
| | | | | | U | |
| | | | | | V | |

I LIMIT (CURRENT LIMIT) This option is used to keep the overcurrent inside set limit. It's necessary to drive primary transformers and cold resistance. It's dual limit for peak and RMS value.

HB Alarm for partial or total load failure and Short Circuit on SCR (relay output)

WiFi not available

Bluetooth Communication and control of the unit via **APP**

APP "RevoBLE" free download from Google Play or Apple Store

Data Logger Reading and data logging of Current (I), Voltage (V) and Power (%) for diagnostics

Energy Totalizer Power reading: totals the energy consumption of the load by providing the kW consumed

No option

Option selected (es cod 3: Logging + Totalizer)

Option codes REVO C 2PH (Digit 12)

| HB | BLUETOOTH | LOGGING | TOTALIZER | Cod. OPTION | NOTES |
|----|-----------|---------|-----------|-------------|-------|
| | | | | 0 | |
| | | | | 1 | |
| | | | | 2 | |
| | | | | 3 | |
| | | | | 4 | |
| | | | | 5 | |
| | | | | 6 | |
| | | | | 7 | |
| | | | | 8 | |
| | | | | 9 | |
| | | | | A | |
| | | | | B | |
| | | | | C | |
| | | | | D | |
| | | | | E | |
| | | | | F | |

HB Alarm for partial or total load failure and Short Circuit on SCR (relay output)

WiFi not available

Bluetooth Communication and control of the unit via **APP**

APP "RevoBLE" free download from Google Play or Apple Store

Data Logger Reading and data logging of Current (I), Voltage (V) and Power (%) for diagnostics

Energy Totalizer Power reading: totals the energy consumption of the load by providing the kW consumed

Option codes REVO C 3PH (Digit 12)

No option

Option selected (es cod 3: Logging + Totalizer)

| ILIMIT | HB | BLUETOOTH | LOGGING | TOTALIZER | Cod. OPTION | NOTES |
|--------|----|-----------|---------|-----------|-------------|-------|
| | | | | | 0 | |
| | | | | | 1 | |
| | | | | | 2 | |
| | | | | | 3 | |
| | | | | | 4 | |
| | | | | | 5 | |
| | | | | | 6 | |
| | | | | | 7 | |
| | | | | | 8 | |
| | | | | | 9 | |
| | | | | | A | |
| | | | | | B | |
| | | | | | C | |
| | | | | | D | |
| | | | | | E | |
| | | | | | F | |
| | | | | | G | |
| | | | | | H | |
| | | | | | I | |
| | | | | | J | |
| | | | | | K | |
| | | | | | L | |
| | | | | | M | |
| | | | | | N | |
| | | | | | O | |
| | | | | | P | |
| | | | | | Q | |
| | | | | | R | |
| | | | | | S | |
| | | | | | T | |
| | | | | | U | |
| | | | | | V | |

I LIMIT (CURRENT LIMIT) This option is used to keep the overcurrent inside set limit. It's necessary to drive primary transformers and cold resistance. This option is not available on 30-35-40A units.

HB Alarm for partial or total load failure and Short Circuit on SCR (relay output).

WiFi not available

Bluetooth Communication and control of the unit via **APP**

APP "RevoBLE" free download from Google Play or Apple Store

Data Logger Reading and data logging of Current (I), Voltage (V) and Power (%) for diagnostics

Energy Totalizer Power reading: totals the energy consumption of the load by providing the kW consumed



Bluetooth option for communication and control via app



App

APP "RevoBLE" free download from Google Play or Apple Store. Connecting to the unit via Bluetooth



WiFi not available

CD3000S

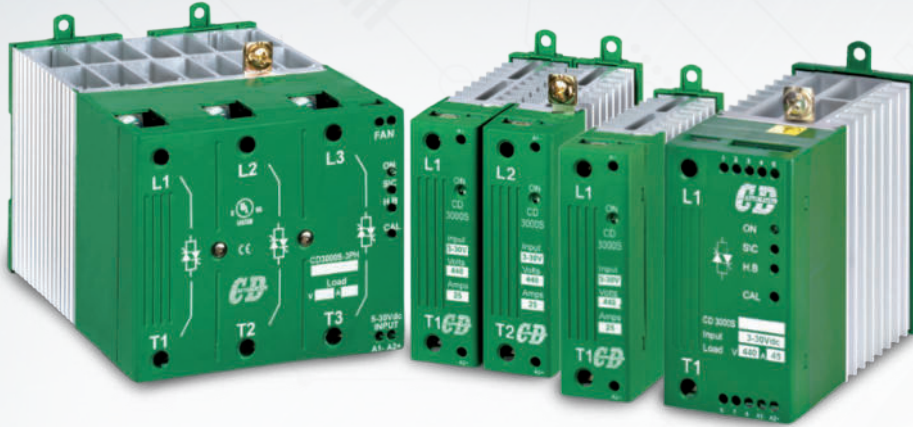

Main features

CD3000S is our low cost family of solid state relays

- Thyristor units from 10A to 90A 1PH, 2PH and 3PH
- Can be used with resistive loads
- Zero crossing firing available with logic input signal (SSR)
- Analog input 4÷20mA or 0÷10V with Burst Firing 4, 8 or 16 cycle at 50% power demand, is available as an option on these models: 1PH from 35A to 90A; 2PH from 45A to 90A.
- Heater break alarm (HB) to diagnose partial or total load failure and short circuit on thyristor, available as an option on these models: 1PH from 35A to 90A; 2PH from 45A to 90A.
- Side-by-side mounting
- Approvals **CE** and **cUL**

Load type

Resistive

Cannot be used for capacitive loading. For information contact our technical department

Industrial applications

- Petrolchemicals
- Platform for oil extraction
- Conventional power generator
- Chemicals and pharmaceuticals
- Autoclaves
- Electric furnaces
- Galvanic process
- Glass industry
- Polysilicon
- Chemical
- Plastic machinery
- Packing machinery
- Automobile
- Paint drying
- UV drying
- Car internal fitting

CD 3000S - FEATURES

| | Description | CD3000S 1PH | | | CD3000S 2PH | | CD3000S 3PH | |
|-----------|---|-------------|------|------|-------------|------|-------------|------|
| | CODE | DS1 | | | DS2 | | DS3 | |
| Load type | Max voltage 480V | ● | | | ● | | ● | |
| | Max voltage 600V (on request) | ● | | | ● | | ● | |
| | Resistive load | ● | | | | | ● | |
| | Resistive load with connection 3PH star/delta | | | | ● | | | |
| | Infrared lamp up to 90A | ● | | | ● | | | |
| Input | SSR from 4 to 30Vdc | ● | | | ● | | ● | |
| | Analog input 0÷10V | ○ | | | ○ | | | |
| | Analog input 4÷20mA | ○ | | | ○ | | | |
| Firing | Zero crossing | ● | | | ● | | ● | |
| | Burst firing 4-8-16 (1) | ○ | | | ○ | | | |
| Current | Current | SIZE | | | SIZE | | SIZE | |
| | | 240V | 480V | 600V | 480V | 600V | 480V | 600V |
| | 10A | | | | S0 | | | |
| | 2x10A | S0 | | | | | | |
| | 15A | | S0 | | S1 | | S2 | |
| | 25A | | S0 | | S1 | | | |
| | 30A | | | | | | S4 | |
| | 35A | | | S3 | | S4 | | |
| | 45A | | | S3 | | S7 | | S6 |
| | 60A | | | S7 | | | | S8 |
| | 75A | | | | | S8 | | S8 |
| | 90A | | | S7 | | S8 | | S8 |

Note 1: Burst Firing 4/8/16 with 4÷20mA or 0÷10V with 12÷24V aux. power supply

CD3000S 1PH

Technical Specification

- **Voltage power supply:** 24V min, 240V, 480V, 600V 50/60Hz
- **Input Signal:** SSR standard up to 90A
Analog input 4÷20mA and 0÷10V available as an option on units from 35A to 90A
- **Firing:** Zero Crossing; Burst Firing 4/8/16 with 4÷20mA or 0÷10V with 12÷24Vac/dc aux. power supply
- **Heater Break Alarm:** Discrimination better than 20%
Circuit microprocessor to diagnose partial or total load failure and short circuit on Thyristor
Automatic calibration of one or more unit at the same time using a dedicated digital input, or for each unit, using the calibration button
Relay output 1A at 230V
- **Approvals:** Compliant with CE and cUL (option in standard units)
- **Mounting:** Din rail
- **Operating temperature:** 0÷40°C up to 90A (for higher temperature see the derating curve)

CD3000S 1PH 10÷90A / 240÷480÷600V

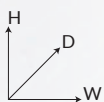

S0
H 120xW 30xD 120 - 0,33 kg
2x10A / 15÷25A



S3
H 120xW 52xD 120 - 0,55 kg
35÷45A



S7
H 120xW 117xD 159 - 1,65 kg
60÷90A

| CD3000S 1PH | 1 | 2 | 3 | 4 | 5 | 6 | 7 | 8 | 9 | 10 | 11 | 12 | 13 | 14 | 15 | 16 |
|-------------------|----------|----------|----------|---|---|---|---|---|---|----|----|----|----|----|----|----|
| ORDER CODE | D | S | 1 | - | - | - | - | - | - | - | - | - | - | - | - | - |

| CURRENT | | 4 | 5 | 6 | |
|----------------|-----------|-----|---|------|--|
| Description | Size | cod | | note | |
| 2x10A | S0 | 2 | X | X | |
| 15A | S0 | 0 | 1 | 5 | |
| 25A | S0 | 0 | 2 | 5 | |
| 35A | S3 | 0 | 3 | 5 | |
| 45A | S3 | 0 | 4 | 5 | |
| 60A | S7 | 0 | 6 | 0 | |
| 90A | S7 | 0 | 9 | 0 | |

| MAX LOAD VOLTAGE | | 7 | |
|-------------------------|--|-----|----------|
| Description | | cod | note |
| 240V | | 2 | |
| 480V | | 4 | 1 |
| 600V | | 6 | 1 |

| AUXILIARY VOLTAGE | | 8 | |
|--|--|-----|------------|
| Description | | cod | note |
| No Auxiliary Voltage supply | | 0 | |
| 12÷24Vac/dc with analog input / HB Alarm | | 4 | 2,3 |

| INPUT | | 9 | |
|---------------------|--|-----|------------|
| Description | | cod | note |
| SSR 4÷30Vdc | | S | |
| Analog input 4÷20mA | | A | 3,5 |
| Analog Input 0÷10V | | V | 3,5 |

| FIRING | | 10 | |
|---|--|-----|------|
| Description | | cod | note |
| Zero Crossing with SSR input | | Z | |
| 4 cycles on + 4 off with analog input | | 4 | |
| 8 cycles on + 8 off with analog input | | 8 | |
| 16 cycles on + 16 off with analog input | | 6 | |

| CONTROL MODE | | 11 | |
|---------------------|--|-----|------|
| Description | | cod | note |
| Open loop | | 0 | |

| FUSES & OPTION | | 12 | |
|---|--|-----|------------|
| Description | | cod | note |
| No fuse / No option | | 0 | |
| No fuse / HB option | | 1 | 3,5 |
| External fuse & fuse holder / No option | | F | |
| External fuse & fuse holder / HB option | | 2 | 3,5 |

| FAN VOLTAGE | | 13 | |
|--------------------|--|-----|------|
| Description | | cod | note |
| No fan | | 0 | |

| APPROVALS | | 14 | |
|------------------------|--|-----|------|
| Description | | cod | note |
| CE for European market | | 0 | |
| CE + cUL | | L | |

| MANUAL | | 15 | |
|---------------|--|-----|------|
| Description | | cod | note |
| None | | 0 | |
| Italian | | 1 | |
| English | | 2 | |
| German | | 3 | |
| French | | 4 | |

| IP PROTECTION | | 16 | |
|---|--|------|----------|
| Description | | code | note |
| Standard IP20 (all unit excluded 60A and 90A) | | 0 | |
| External IP20 protection for size S7 (60-90A) | | P | 4 |

Note 1: 480V and 600V not available for 2x10A

Note 2: Necessary with 0÷10V - 4÷20mA and HB alarm

Note 3: Option available 35÷90A

Note 4: IP20 is standard on all units with exception of S7 size (60-90A). To comply with IP20 use "P" option at digit 16

Note 5: HB not available with UL approval

CD3000S 2PH

Technical Specification

- **Voltage power supply:** 24V min, 480V, 600V 50/60Hz
- **Input Signal:** SSR
Analog input 4÷20mA and 0÷10V available from 45A to 90A
- **Firing:** Zero Crossing; Burst Firing 4/8/16 with 4÷20mA or 0÷10V with 12÷24Vac/dc aux. power supply
- **Fan Voltage Supply:** for unit ≥75A; 230V standard (115V option)
- **Heater Break Alarm:** Discrimination better than 20%
Circuit microprocessor to diagnose partial or total load failure and short circuit on Thyristor
Relay output 1A at 230V
Automation calibration of one or more unit at the same time using a dedicated digital input, or for each unit, by using the calibration button
- **Approvals:** Compliant with CE and cUL (option in standard units)
- **Mounting:** Din rail
- **Operating temperature:** 0÷40° up to 90A (for higher temperature see the derating curve)

CD3000S 2PH 10÷90A / 480÷600V

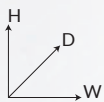

S0
H 120xW 30xD 120 - 0,33 kg
10A



S1
H 120xW 60xD 120 - 0,70 kg
15-25A

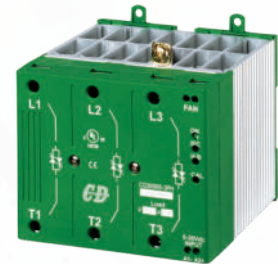

S4
H 120xW 117xD 123 - 1,15 kg
35A

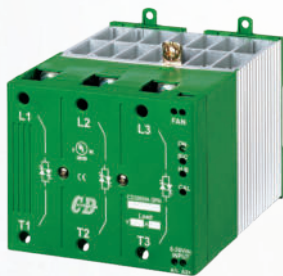

S7
H 120xW 117xD 159 - 1,65 kg
45A



S8
H 138xW 117xD 159 - 2,10 kg
75÷90A

CD3000S 2PH

| | | | | | | | | | | | | | | | | | |
|-------------------|----------|----------|----------|---|---|---|---|---|---|---|----|----|----|----|----|----|----|
| | 1 | 2 | 3 | 4 | 5 | 6 | | 7 | 8 | 9 | 10 | 11 | 12 | 13 | 14 | 15 | 16 |
| ORDER CODE | D | S | 2 | - | - | - | - | - | - | - | - | - | - | - | - | - | - |

| CURRENT | | 4 | 5 | 6 | |
|----------------|-----------|-----|---|------|----------|
| Description | Size | cod | | note | |
| 10A | S0 | 0 | 1 | 0 | 1 |
| 15A | S1 | 0 | 1 | 5 | |
| 25A | S1 | 0 | 2 | 5 | |
| 35A | S4 | 0 | 3 | 5 | |
| 45A | S7 | 0 | 4 | 5 | |
| 75A | S8 | 0 | 7 | 5 | |
| 90A | S8 | 0 | 9 | 0 | |

| MAX LOAD VOLTAGE | | 7 | |
|-------------------------|--|-----|------|
| Description | | cod | note |
| 480V | | 4 | |
| 600V | | 6 | |

| AUXILIARY VOLTAGE | | 8 | |
|--|--|-----|------------|
| Description | | cod | note |
| No Auxiliary Voltage supply | | 0 | |
| 12÷24Vac/dc with analog input / HB Alarm | | 4 | 2,3 |

| INPUT | | 9 | |
|---------------------|--|-----|------------|
| Description | | cod | note |
| SSR 4÷30Vdc | | S | |
| Analog input 4÷20mA | | A | 3,5 |
| Analog Input 0÷10V | | V | 3,5 |

| FIRING | | 10 | |
|---|--|-----|------|
| Description | | cod | note |
| Zero Crossing with SSR input | | Z | |
| 4 cycles on + 4 off with analog input | | 4 | |
| 8 cycles on + 8 off with analog input | | 8 | |
| 16 cycles on + 16 off with analog input | | 6 | |

| CONTROL MODE | | 11 | |
|---------------------|--|-----|------|
| Description | | cod | note |
| Open loop | | 0 | |

| FUSES & OPTION | | 12 | |
|--|--|-----|------------|
| Description | | cod | note |
| No fuse / No option | | 0 | |
| No fuse / HB option for SSR input | | 1 | 3,5 |
| No fuse / HB option for analog input | | 1 | 3,5 |
| External fuse + fuse holder / No option | | F | |
| External fuse + fuse holder / HB option for SSR input | | 2 | 3,5 |
| External fuse + fuse holder / HB option for analog input | | 2 | 3,5 |

| FAN VOLTAGE | | 13 | |
|---|--|-----|------|
| Description | | cod | note |
| No Fan for unit <75A | | 0 | |
| Fan 115V option - for 75A and 90A units | | 1 | |
| Fan 230V standard - for 75A and 90A units | | 2 | |

| APPROVALS | | 14 | |
|------------------------|--|-----|------|
| Description | | cod | note |
| CE for European market | | 0 | |
| CE + cUL | | L | |

| MANUAL | | 15 | |
|---------------|--|-----|------|
| Description | | cod | note |
| None | | 0 | |
| Italian | | 1 | |
| English | | 2 | |
| German | | 3 | |
| French | | 4 | |

| IP PROTECTION | | 16 | |
|---|--|-----|------|
| Description | | cod | note |
| Standard IP20 (all unit excluded 45A, 75A, 90A) | | 0 | |
| External IP20 protection for size S7/S8 (45A, 75A, 90A) | | P | |

Note 1: For 10A 600V cUL us not available

Note 2: Necessary with 0÷10V - 4÷20mA or HB alarm

Note 3: Option available from 45÷90A

Note 4: IP20 is standard on all units with exception of S7 and S8 size (45-75-90A). To comply with IP20 use "P" option at digit 16

Note 5: HB not available with cUL us approval

CD3000S 3PH

Technical Specification

- **Voltage power supply:** 24V min, 480V Max, 600V on request
- **Input Signal:** SSR
- **Firing:** Zero Crossing
- **Fan Voltage Supply:** 230V
- **Approvals:** Compliant with CE and cUL (option)
- **Mounting:** Din rail
- **Operating Temperature:** 0÷40° up to 90A included (for higher temperature see the derating curve)

Not available on this unit

- Heater Break Alarm
- Analog input 4÷20mA and 0÷10V

CD3000S 3PH 15÷90A / 480÷600V

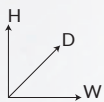

S2
H 120xW 92xD 120 - 1,05 kg
15A

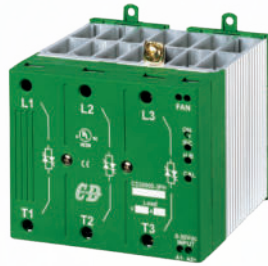

S4
H 120xW 117xD 123 - 1,15 kg
30A



S6
H 138xW 117xD 123 - 1,80 kg
45A



S8
H 138xW 117xD 159 - 2,10 kg
60÷90A

CD3000S 3PH

| | | | | | | | | | | | | | | | | | |
|-------------------|---|---|---|---|---|---|---|---|---|---|----|----|----|----|----|----|----|
| | 1 | 2 | 3 | 4 | 5 | 6 | | 7 | 8 | 9 | 10 | 11 | 12 | 13 | 14 | 15 | 16 |
| ORDER CODE | D | S | 3 | - | - | - | - | - | - | - | - | - | - | - | - | - | - |

| CURRENT | | 4 | 5 | 6 | |
|----------------|------|-----|---|---|------|
| Description | Size | cod | | | note |
| 15A | S2 | 0 | 1 | 5 | |
| 30A | S4 | 0 | 3 | 0 | |
| 45A | S6 | 0 | 4 | 5 | |
| 60A | S8 | 0 | 6 | 0 | |
| 75A | S8 | 0 | 7 | 5 | |
| 90A | S8 | 0 | 9 | 0 | |

| MAX LOAD VOLTAGE | | 7 | |
|-------------------------|--|-----|------|
| Description | | cod | note |
| 480V | | 4 | |
| 600V | | 6 | |

| AUXILIARY VOLTAGE | | 8 | |
|-----------------------------|--|-----|------|
| Description | | cod | note |
| No Auxiliary Voltage supply | | 0 | |

| INPUT | | 9 | |
|--------------|--|-----|------|
| Description | | cod | note |
| SSR | | S | |

| FIRING | | 10 | |
|---------------|--|-----|------|
| Description | | cod | note |
| Zero Crossing | | Z | |

| CONTROL MODE | | 11 | |
|---------------------|--|-----|------|
| Description | | cod | note |
| Open loop | | 0 | |

| FUSES & OPTION | | 12 | |
|-----------------------------|--|-----|------|
| Description | | cod | note |
| No fuse | | 0 | |
| External fuse + fuse holder | | F | |

| FAN VOLTAGE | | 13 | |
|--|--|-----|------|
| Description | | cod | note |
| No Fan for unit <45A | | 0 | |
| Fan 115V option - for 45A to 90A units | | 1 | |
| Fan 230V Standard - for 45A to 90A units | | 2 | |

| APPROVALS | | 14 | |
|------------------------|--|-----|------|
| Description | | cod | note |
| CE for European market | | 0 | |
| CE + cUL | | L | |

| MANUAL | | 15 | |
|---------------|--|-----|------|
| Description | | cod | note |
| None | | 0 | |
| Italian | | 1 | |
| English | | 2 | |
| German | | 3 | |
| French | | 4 | |

| IP PROTECTION | | 16 | |
|--|--|-----|------|
| Description | | cod | note |
| IP20 standard (all unit excluded size S8, from 60A to 90A) | | 0 | |
| External IP20 protection for size S8 (from 60A to 90A) | | P | 1 |

Note 1: IP20 is standard on all units with exception of S8 size (60÷90A). To comply with IP20 use "P" option at digit 16

REVO PN

Integrated
fieldbus

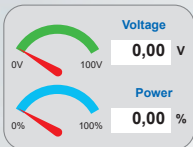

Configurator
software

TIA PORTAL
V16

SIEMENS

Libraries



4 - 8
One Phase Channels



12 - 16
One Phase Channels



12 - 24 One Phase Channels
shared on the three phases
20 - 24 One Phase Channels

Main features

Multi-zone control system with energy efficiency (Power Management)

- **Fieldbus: range of communication protocols available**
Modbus® RTU, Profibus® DP, Profinet® IO, Modbus® TCP, Ethernet IP
- From 12 to 24 single phase independent channels balanced on the three different phases
- From 4 to 24 single phase independent channels sharing the same phase connection Phase-Neutral or Phase-Phase
- Nominal current in continuous service Max 25A for each load
- Max peak current (10ms) 700A
- Nominal Voltage range 24÷600V, 3 phase
- Current reading with integrated CT for each channel
- Load and short circuit thyristor diagnostics for each channel
- "Enable" command for each channel
- CE approval
- UL approval max 300V
- **Guided configuration via free software**, available on www.cdautomation.com
- Siemens **TIA Portal Libraries** for data exchange with our products (from V16)

Load type

Resistive / Short wave (IRSW) and fast medium wave (IRMW) infrared lamp

Cannot be used for capacitive loading. For information contact our technical department

Industrial applications

- Plastic industry
- Paint drying
- PET moulding
- Extrusion/Co-extrusion
- Furnaces with IR lamps
- Multizone furnaces
- Renewable energies
- Bio Packaging

REVO PN - FEATURES

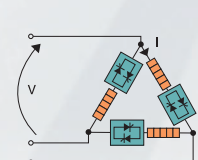
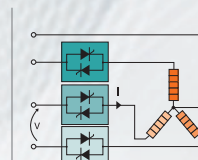
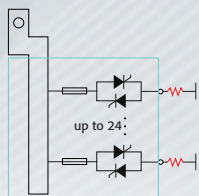

| CODE | RPN 104 | RPN 108 | RPN 112 RPN 120 | RPN 116 RPN 124 | RPN 412 | RPN 424 | RPN 612 | RPN 624 | REVO PB (PN Basic) | |
|--|--|---------|--------------------|--------------------|--|---------|---|---------|-----------------------|--|
| Connection | Phase-Phase | | Phase-Neutral | | Ph-N connect. Shared on the three phases | | Ph-Ph connect. Shared on the three phases | | | |
| Channel | 4 | 8 | 12 20 | 16 24 | 12 | 24 | 12 | 24 | 3 | |
| N° of Control Legs for each Channel | 2PH | 2PH | 3PH | 3PH | 1PH | 1PH | 1PH | 1PH | 1PH | |
| General features | Polymeric V2 | | | | | | | | | |
| IP code | 20 | | | | | | | | | |
| Aux voltage | 24Vdc | | | | | | | | | |
| Input | Number of sensors used | | | | | | | | | |
| | 4 | 8 | 12 20 | 16 24 | 12 | 24 | 12 | 24 | 3 | |
| | Configurable Digital Input calibration | | | | | | | | | |
| | max. 50mA | | | | | | | | | |
| Output | 25A for each channel, Fuse 1260 A ² S | | | | | | | | Up to 90A | |
| Firing | Half Cycle at 50% power demand | | | | Not available | | Standard | | Standard | |
| | Single Cycle at 50% power demand | | | | Standard | | Standard | | Standard | |
| Control | Open Loop | | | | Standard | | | | | |
| | Power Feedback | | | | Standard | | | | | |
| Features | Heater Break + Thyristor short circuit | | | | Standard | | | | | |
| | Current Measurement on communication | | | | Standard | | | | | |
| | Voltage measurement | | | | Standard | | | | | |
| | Power measurement | | | | Standard | | | | | |
| | Three Phase balanced load | | | | Standard | | | | No | |
| Communication | N°1 Modbus TCP and N°3 Modbus RTU Slave | | | | Standard | | | | 1 | |
| | Modbus Master | | | | Yes | | | | No | |
| | Profibus DP and Modbus TCP | | | | Option | | | | External module | |
| | Profinet and Modbus TCP | | | | Option | | | | | |
| | Ethernet IP and Modbus TCP | | | | Option | | | | | |
| Digital Input | N° digital input | | | | 4 | | | | 3 | |
| | Enable/Disable Function | | | | OK | | | | | |
| Relay Output | Relay Output | | | | Option | | | | | |
| Options | Operator panel KPPC | | | | Option | | | | | |
| Temperature Control | Can be added externally | | | | Option | | | | No | |

From 4 up to 24 single phase independent channels sharing the same phase connection

Diagram 104

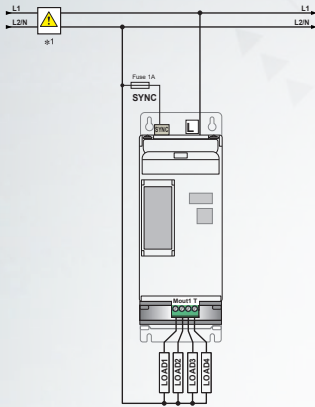

Diagram 108

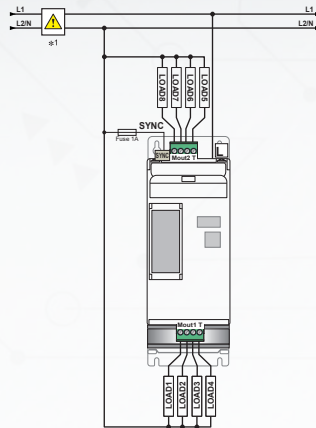

Diagram 112

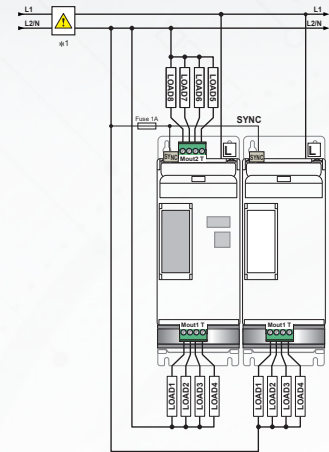

Diagram 116

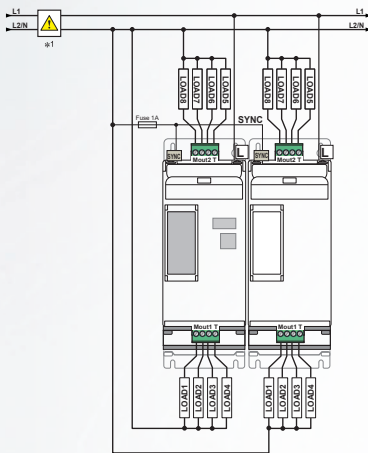

Diagram 120

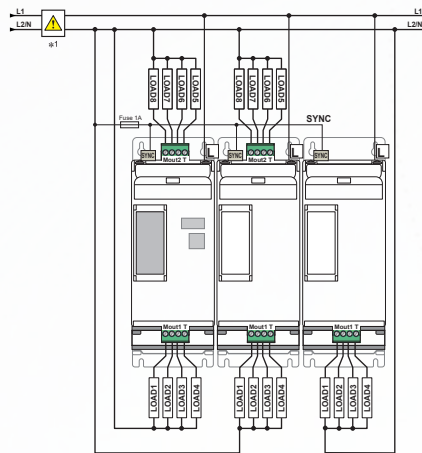
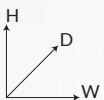
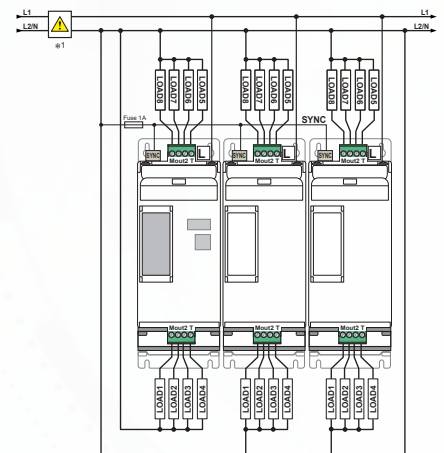

Diagram 124



SR15
H 273xW 93xD 170
3,6 kg



SR15 x2
H 273xW 186xD 170
7,0 kg



SR15 x3
H 273xW 281xD 170
10,6 kg

| REVO PN | 1 | 2 | 3 | 4 | 5 | 6 | 7 | 8 | 9 | 10 | 11 | 12 | 13 | 14 | 15 | 16 |
|-------------------|----------|----------|---|---|---|---|---|---|---|----|----|----|----|----|----|----|
| ORDER CODE | P | N | - | - | - | - | - | - | - | - | - | - | - | - | - | - |

| CURRENT | 3 | 4 | 5 |
|--|-----|---|------|
| Description | cod | | note |
| 1 PH 4 zones, all F1-N or F1-F2 (See diagram 104) | 1 | 0 | 4 |
| 1 PH 8 zones, all F1-N or F1-F2 (See diagram 108) | 1 | 0 | 8 |
| 1 PH 12 zones, all F1-N or F1-F2 (See diagram 112) | 1 | 1 | 2 |
| 1 PH 16 zones, all F1-N or F1-F2 (See diagram 116) | 1 | 1 | 6 |
| 1 PH 20 zones, all F1-N or F1-F2 (See diagram 120) | 1 | 2 | 0 |
| 1 PH 24 zones, all F1-N or F1-F2 (See diagram 124) | 1 | 2 | 4 |

| MAX VOLTAGE | 6 |
|--------------------|-----|
| Description | cod |
| 480V | 4 |

| COMMUNICATION | 7 |
|---|-----|
| Description | cod |
| N° 1 Ethernet Port, Modbus® TCP and n°3 Modbus® RTU | 1 |
| N°1 ProfiNet®, n° 1 Modbus® TCP, n°3 Modbus® RTU | 5 |
| N° 1 EtherCAT, n° 1 Modbus® TCP, n°3 Modbus® RTU | 6 |
| N° 1 Ethernet IP, n° 1 Modbus® TCP, n°3 Modbus® RTU | 7 |

| AUXILIARY VOLTAGE | 8 |
|--------------------------|-----|
| Description | cod |
| 24Vdc | 4 |

| INPUT | 9 |
|------------------------------|-----|
| Description | cod |
| None, use only communication | 0 |

| FIRING | 10 |
|--------------------|-----|
| Description | cod |
| Half Cycle | 1 |
| Single Cycle | 2 |

| CONTROL MODE | 11 |
|---------------------|-----|
| Description | cod |
| Open Loop | 1 |
| Power Feed Back | 2 |

| FUSES + FUSE HOLDER | 12 |
|--|-----|
| Description | cod |
| Low Speed Fuse & Fuse Holder for each channel (see option table) | ... |
| Extra Rapid Fuse & Fuse Holder for each channel | F |

| FAN VOLTAGE | 13 |
|--------------------|-----|
| Description | cod |
| 24Vdc fan | 3 |

| APPROVALS | 14 |
|------------------------|-----|
| Description | cod |
| CE for European market | 0 |
| UL max 300V | L |

| MANUAL | 15 |
|--------------------|-----|
| Description | cod |
| None | 0 |
| Italian | 1 |
| English | 2 |
| German | 3 |
| French | 4 |

| VERSION | 16 |
|---|-----|
| Description | cod |
| Each channel has a dedicated current sensor integrated in the units | 4 |

Note 1: These fuses do not protect the Thyristors. You need external fuses. This solution is recommended for current IRSW Lamp.

Option table

| Fuse type | Max current | COD |
|----------------------------|-------------|-----|
| Extrarapid fuse (Standard) | 32A | F |
| Low speed fuse | 2A | A |
| Low speed fuse | 4A | B |
| Low speed fuse | 6A | C |
| Low speed fuse | 8A | D |
| Low speed fuse | 10A | E |
| Low speed fuse | 12A | G |
| Low speed fuse | 16A | H |
| Low speed fuse | 20A | I |
| Low speed fuse | 25A | L |
| Low speed fuse | 32A | N |
| Low speed fuse | Various | V |

All low speed fuses do not protect thyristor module

From 12 up to 24 single phase independent channels balanced on the three different phases

Diagram 412

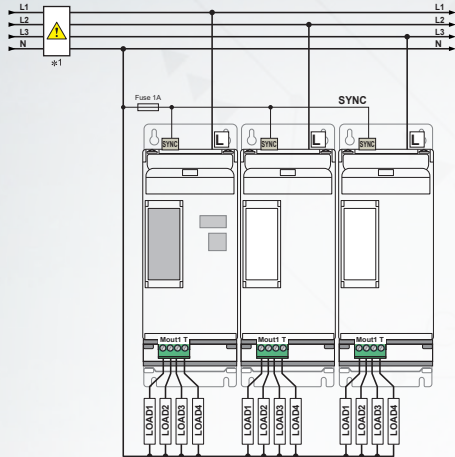

Diagram 612

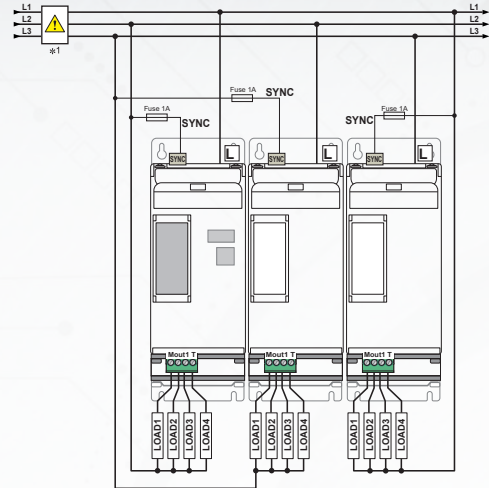

Diagram 424

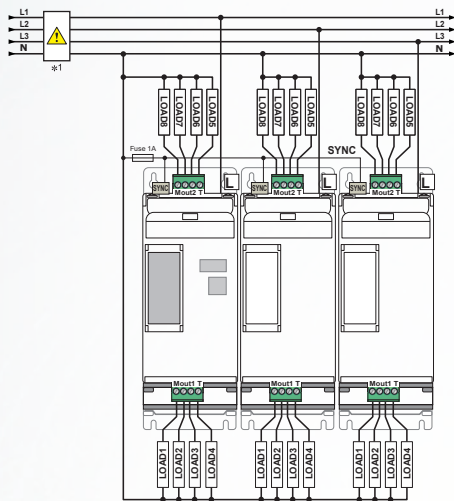
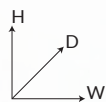
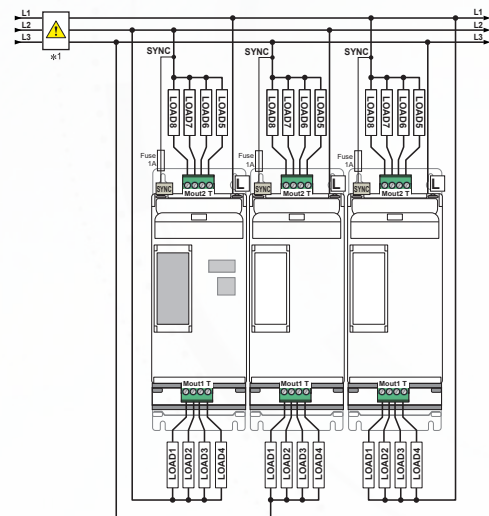

Diagram 624



SR15 x3
H 273 x W 281 x D 170
10,6 kg

| REVO PN | 1 | 2 | 3 | 4 | 5 | 6 | 7 | 8 | 9 | 10 | 11 | 12 | 13 | 14 | 15 | 16 |
|-------------------|---|---|---|---|---|---|---|---|---|----|----|----|----|----|----|----|
| ORDER CODE | P | N | - | - | - | - | - | - | - | - | - | - | - | - | - | - |

| CURRENT | 3 | 4 | 5 | |
|--|---|-----|---|------|
| Description | | cod | | note |
| 1PH 12 zones (n°4 zones F1-N; n°4 zones F2-N; n°4 zones F3-N) (See diagram 412) | 4 | 1 | 2 | |
| 1PH 24 zones (n°8 zones F1-N; n°8 zones F2-N; n°8 zones F3-N) (See diagram 424) | 4 | 2 | 4 | |
| 1PH 12 zones (n°4 zones F1-F2; n°4 zones F2-F3; n°4 zones F1-F3) (See diagram 612) | 6 | 1 | 2 | |
| 1PH 24 zones (n°8 zones F1-F2; n°8 zones F2-F3; n°8 zones F1-F3) (See diagram 624) | 6 | 2 | 4 | |

| MAX VOLTAGE | 6 | |
|--------------------|-----|------|
| Description | cod | note |
| 480V | 4 | |

| COMMUNICATION | 7 | |
|---|-----|------|
| Description | cod | note |
| N° 1 Ethernet Port, Modbus® TCP and n°3 Modbus® RTU | 1 | |
| N°1 ProfiNet®, n° 1 Modbus® TCP, n°3 Modbus® RTU | 5 | |
| N° 1 EtherCAT, n° 1 Modbus® TCP, n°3 Modbus® RTU | 6 | |
| N° 1 Ethernet IP, n° 1 Modbus® TCP, n°3 Modbus® RTU | 7 | |

| AUXILIARY VOLTAGE | 8 | |
|--------------------------|-----|------|
| Description | cod | note |
| 24Vdc | 4 | |

| INPUT | 9 | |
|------------------------------|-----|------|
| Description | cod | note |
| None, use only communication | 0 | |

| FIRING | 10 | |
|--------------------|-----|------|
| Description | cod | note |
| Half cycle | 1 | |
| Single cycle | 2 | |

| CONTROL MODE | 11 | |
|---------------------|-----|------|
| Description | cod | note |
| Open Loop | 1 | |
| Power Feed Back | 2 | |

| FUSES + FUSE HOLDER | 12 | |
|---|-----|------|
| Description | cod | note |
| Low Speed Fuse & Fuse Holder for each channel (see option table) | ... | 1 |
| Extra Rapid Fuse & Fuse Holder for each channel | F | |

| FAN VOLTAGE | 13 | |
|--------------------|-----|------|
| Description | cod | note |
| 24Vdc fan | 3 | |

| APPROVALS | 14 | |
|------------------------|-----|------|
| Description | cod | note |
| CE for European market | 0 | |
| UL max 300V | L | |

| MANUAL | 15 | |
|--------------------|-----|------|
| Description | cod | note |
| None | 0 | |
| Italian | 1 | |
| English | 2 | |
| German | 3 | |
| French | 4 | |

| VERSION | 16 | |
|---|------|------|
| Description | code | note |
| Each channel has a dedicated current sensor integrated in the units | 4 | |

Note 1: fuses do not protect the Thyristors. You need external fuses. This solution is recommended for current IRSW Lamp.

Option table

| Fuse type | Max current | COD |
|----------------------------|-------------|-----|
| Extrarapid fuse (Standard) | 32A | F |
| Low speed fuse | 2A | A |
| Low speed fuse | 4A | B |
| Low speed fuse | 6A | C |
| Low speed fuse | 8A | D |
| Low speed fuse | 10A | E |
| Low speed fuse | 12A | G |
| Low speed fuse | 16A | H |
| Low speed fuse | 20A | I |
| Low speed fuse | 25A | L |
| Low speed fuse | 32A | N |
| Low speed fuse | Various | V |

All low speed fuses do not protect thyristor module

REVO PB

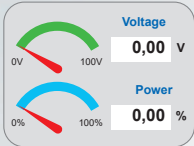

Configurator
software



REVO PB: REVO PN power extension up to 90A

Created specifically for industrial multi-zone applications, REVO PB can be configured to control between 3 and 9 channels/zones.

- Available sizes: 35A, 50A, 75A, 90A
- Three zones thyristor controller with power optimization algorithm (power management)
- Modbus® RTU communication protocol on RS485
- Extrarapid fixed fuses
- Current reading with integrated CT for each channel
- Firing: Single cycle, Half cycle
- Load and SCR diagnostics for each channel
- Outputs for alarms
- “Enable” command for each channel
- **CE** approval
- **Guided configuration via free software**, available on www.cdautomation.com

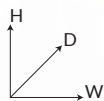

SR25
H 165 x W 116 x D 183 - 2,35 kg
35+90A

| | | | | | | | | | | | | | | | | |
|------------|---|---|---|---|---|---|---|---|---|----|----|----|----|----|----|----|
| REVO PB | 1 | 2 | 3 | 4 | 5 | 6 | 7 | 8 | 9 | 10 | 11 | 12 | 13 | 14 | 15 | 16 |
| ORDER CODE | P | B | 3 | - | - | - | - | - | - | - | - | - | - | - | - | - |

| CURRENT | 4 | 5 | 6 | |
|-------------|-----|---|------|--|
| Description | cod | | note | |
| 35A | 0 | 3 | 5 | |
| 50A | 0 | 5 | 0 | |
| 75A | 0 | 7 | 5 | |
| 90A | 0 | 9 | 0 | |

| MAX VOLTAGE | 7 | |
|-------------|-----|------|
| Description | cod | note |
| 480V | 4 | |
| 600V | 6 | |

| AUXILIARY VOLTAGE | 8 | |
|-------------------|-----|------|
| Description | cod | note |
| 24Vdc | 4 | |

| INPUT | 9 | |
|---------------------------------------|-----|------|
| Description | cod | note |
| RS485 Modbus RTU Communication and DI | 0 | |

| FIRING | 10 | |
|--------------|-----|------|
| Description | cod | note |
| Half Cycle | 0 | |
| Single Cycle | 1 | |

| CONTROL MODE | 11 | |
|--------------|-----|------|
| Description | cod | note |
| No Feed-back | 1 | |
| Power Vxl | 2 | |

| OPTION | 12 | |
|-----------------------------|-----|------|
| Description | cod | note |
| Display, Heater Break ALARM | 0 | |

| FAN VOLTAGE | 13 | |
|-------------|-----|------|
| Description | cod | note |
| 24Vdc FAN | 3 | |

| APPROVALS | 14 | |
|------------------------|-----|------|
| Description | cod | note |
| CE for European market | 0 | |

| LOAD TYPE | 15 | |
|------------------------------|-----|------|
| Description | cod | note |
| 1PH Normal resistance | 0 | |
| 1PH IRSW Infrared Short Wave | 1 | |

| VERSION | 16 | |
|------------------|-----|------|
| Description | cod | note |
| Standard Version | 0 | |

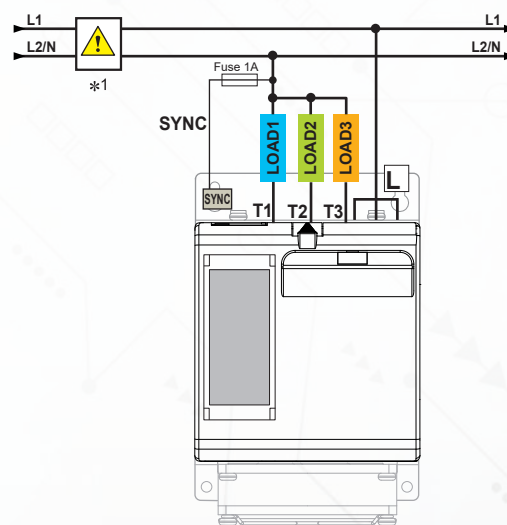

REVO PC

Integrated
Fieldbus

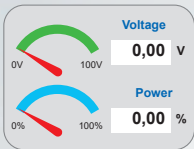

Configurator
software

TIA PORTAL
V16

SIEMENS

Libraries



Main features

REVO PC system is based on an intelligent unit that manages one or more basic SCR power controller. All currents are measured with an external current transformer. REVO PC acquires the power setpoint from different sources including: single or multi zone temperature controller, PLC or HMI.

- **Fieldbus: range of communication protocols available**
Modbus® RTU, Profibus® DP, Profinet® IO, Modbus® TCP, Ethernet IP
- For standard resistors and IR lamps
- To use with REVO S and REVO Sx in “Y” configuration
- Firing: Single Cycle, Half Cycle and Dynamic Burst Firing
- Reduces power peaks and increases energy savings (power management)
- Heater Break alarm and “Enable” command for each channel
- **Guided configuration via free software**, available on www.cdautomation.com
- Siemens **TIA Portal Libraries** for data exchange with our products (from V16)



A 269 x L 93 x P 95
0,6 kg

Control unit

REVO PC up to 24 channels

- SSR output “Y” to control up to 24 REVO S 1PH
- High precision voltage transducer
- RS485 and Modbus TCP available as standard

Power Unit

REVO S 1PH “Y”

- SCR power switches from 30A to 800A
- Extrarapid internal fuses
- Max voltage 480V - 600V - 690V
- High precision integrated current transducer

REVO Sx “Y”

- SCR power controllers from 50A to 90A
- External CT
- Multichannel unit

Load type

Resistive / Short wave (IRSW) and fast medium wave (IRMW) infrared lamp

Cannot be used for capacitive loading. For information contact our technical department

Industrial applications

- Plastic industry
- Paint drying
- PET moulding
- Extrusion/Co-extrusion
- Furnaces with IR lamps
- Multizone furnaces
- Renewable energies
- Bio Packaging

REVO PC - FEATURES

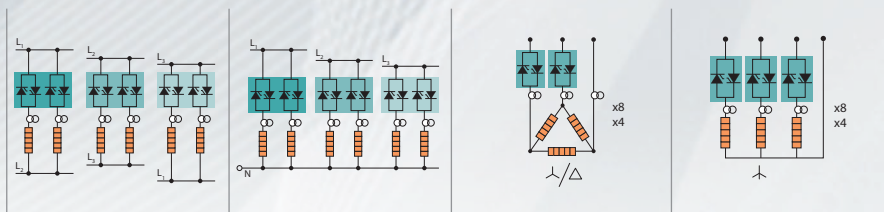

| CODE | | RPC612 | RPC624 | RPC412 | RPC424 | RPC204 | RPC208 | RPC304 | RPC308 |
|-------------------------------------|---|---|--------|---------------|--------|---------------|--------|----------|--------|
| Connection | | Phase-Phase shared on three phases | | Phase-Neutral | | 2 Legs | | 3 legs | |
| Channels | | 12 | 24 | 12 | 24 | 4 | 8 | 4 | 8 |
| N° of Control Legs for each Channel | | 1PH | 1PH | 1PH | 1PH | 2PH | 2PH | 3PH | 3PH |
| General features | Cover and socket material | Polymeric V2 | | | | | | | |
| | IP code | 20 | | | | | | | |
| | Aux Voltage | 24Vdc | | | | | | | |
| Input | Number of sensor used | 12 | 24 | 12 | 24 | 12 | 24 | 12 | 24 |
| | Configurable Digital Input calibration | max. 50mA | | | | | | | |
| Output | | 25A for each channel, Fuse I ² t 1260 A ² S | | | | | | | |
| Firing | Half Cycle at 50% power demand | Standard | | | | Not available | | Standard | |
| | Single Cycle at 50% power demand | Standard | | | | Standard | | | |
| Control | Open Loop | Standard | | | | | | | |
| | Power Feedback | Standard | | | | | | | |
| Features | Heater Break + Thyristor short circuit | Standard | | | | | | | |
| | Current Measurement on communication | Standard | | | | | | | |
| | Voltage measurement | Standard | | | | | | | |
| | Power measurement | Standard | | | | | | | |
| | Three Phase balanced load | Standard | | | | | | | |
| Communication | N°1 Modbus TCP and N°3 Modbus RTU Slave | Standard | | | | | | | |
| | Profibus DP and Modbus TCP | Option | | | | | | | |
| | Profinet and Modbus TCP | Option | | | | | | | |
| | Ethernet IP and Modbus TCP | Option | | | | | | | |
| Digital Input | N° digital input | 4 | | | | | | | |
| | Enable Disable Function | Standard | | | | | | | |
| Relay Output | Relay Output | Option | | | | | | | |
| Option | Operator panel KPPC | Option | | | | | | | |
| Temperature control | Can be added externally | Option | | | | | | | |

RPC612 / RPC624

up to 24 1PH channel shared on three phases

CONNECTION PHASE TO PHASE

| REVO PC | 1 | 2 | 3 | 4 | 5 | 6 | 7 | 8 | 9 | 10 | 11 | 12 | 13 | 14 | 15 | 16 |
|-------------------|---|---|---|---|---|---|---|---|---|----|----|----|----|----|----|----|
| ORDER CODE | R | P | C | - | - | - | - | - | - | - | - | - | - | - | - | - |

| CONNECTION | | 4 | |
|--|--|-----|------|
| Description | | cod | note |
| F1-F2; F2-F3; F1-F3 All the 1PH channel can be balanced on the three phases Phase to Phase | | 6 | |

| FIRING | | 12 | |
|--------------------------------|--|-----|------|
| Description | | cod | note |
| Half Cycle at 50% power demand | | 1 | |
| One Cycle at 50% power demand | | 2 | |

| CHANNELS | | 5 | 6 | |
|--|--|-----|------|--|
| Description | | cod | note | |
| 12 channel REVO PC to drive 12 REVOS-1PH Max with Random Firing | | 1 | 2 | |
| 24 channel REVO PC to drive 24 REVOS-1PH Max with Random Firing | | 2 | 4 | |

| FEEDBACK (Control Mode) | | 13 | |
|-------------------------|--|-----|------|
| Description | | cod | note |
| No Feedback | | 1 | |
| Power | | 2 | |

| One Current Sensor Input for each channel | | 7 | 8 | 9 | |
|--|--|-----|------|---|--|
| Description | | cod | note | | |
| Current Sensor is included and integrated with REVO S 1PH units with "Y" Option | | 0 | 0 | 0 | |

| APPROVALS | | 14 | |
|------------------------|--|-----|------|
| Description | | cod | note |
| CE for European market | | 1 | |
| CE + cUL (pending) | | L | |

| COMMUNICATION | | 10 | |
|--|--|-----|------|
| Description | | cod | note |
| N°1 Modbus® TCP, n°3 Modbus® RTU, CD Bus | | 1 | |
| N°1 Profibus-DP® port, Modbus TCP, Modbus RTU, CD Bus (with external module) <i>on request only</i> | | 4 | |
| N°1 ProfiNet®, n° 1 Modbus® TCP, n°3 Modbus® RTU, CD Bus | | 5 | |
| N° 1 EtherCAT, n° 1 Modbus® TCP, n°3 Modbus® RTU, CD Bus | | 6 | |
| N° 1 Ethernet IP, n° 1 Modbus® TCP, n°3 Modbus® RTU, CD Bus | | 7 | |

| MANUAL | | 15 | |
|-------------|--|-----|------|
| Description | | cod | note |
| None | | 0 | |
| Italian | | 1 | |
| English | | 2 | |
| German | | 3 | |
| French | | 4 | |

| Aux Voltage to be coupled with an external transformer | | 11 | |
|--|--|-----|------|
| Description | | cod | note |
| 24Vdc | | 4 | |

| VERSION | | 16 | |
|-------------|--|-----|------|
| Description | | cod | note |
| Version 2 | | 2 | |

Connection example

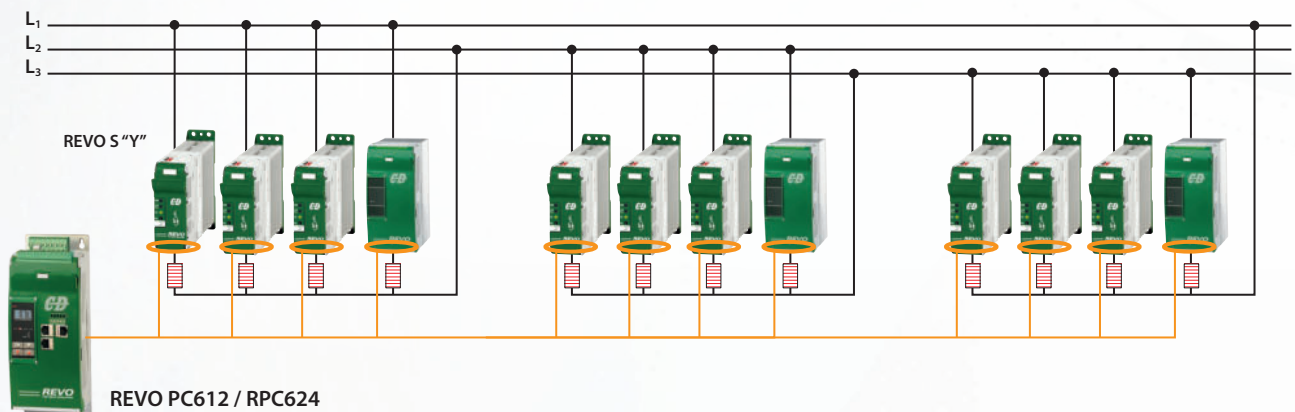

RPC412 / RPC424

up to 24 1PH channel balanced on three phases

CONNECTION PHASE TO NEUTRAL

| | | | | | | | | | | | | | | | | |
|------------|---|---|---|---|---|---|---|---|---|----|----|----|----|----|----|----|
| REVO PC | 1 | 2 | 3 | 4 | 5 | 6 | 7 | 8 | 9 | 10 | 11 | 12 | 13 | 14 | 15 | 16 |
| ORDER CODE | R | P | C | - | - | - | - | - | - | - | - | - | - | - | - | - |

| | | |
|---|-----|------|
| CONNECTION | 4 | |
| Description | cod | note |
| F1-N; F2-N; F3-N All the 1PH channel can be balanced on the three phases Phase to Neutral | 4 | |

| | | |
|--------------------------------|-----|------|
| FIRING | 12 | |
| Description | cod | note |
| Half Cycle at 50% power demand | 1 | |
| One Cycle at 50% power demand | 2 | |

| | | | |
|--|-----|------|--|
| CHANNELS | 5 | 6 | |
| Description | cod | note | |
| 12 channel REVO PC to drive 12 REVOS-1PH Max with Random Firing | 1 | 2 | |
| 24 channel REVO PC to drive 24 REVOS-1PH Max with Random Firing | 2 | 4 | |

| | | |
|--------------------------------|-----|------|
| FEEDBACK (Control Mode) | 13 | |
| Description | cod | note |
| No Feedback | 1 | |
| Power | 2 | |

| | | | | |
|--|-----|------|---|--|
| One Current Sensor Input for each channel | 7 | 8 | 9 | |
| Description | cod | note | | |
| Current Sensor is included and integrated with REVO S 1PH units with "Y" Option | 0 | 0 | 0 | |

| | | |
|------------------------|-----|------|
| APPROVALS | 14 | |
| Description | cod | note |
| CE for European market | 1 | |
| CE + cUL (pending) | L | |

| | | |
|--|-----|------|
| COMMUNICATION | 10 | |
| Description | cod | note |
| N°1 Modbus® TCP, n°3 Modbus® RTU, CD Bus | 1 | |
| N°1 Profibus-DP® port, Modbus TCP, Modbus RTU, CD Bus (with external module) <i>on request only</i> | 4 | |
| N°1 ProfiNet®, n° 1 Modbus® TCP, n°3 Modbus® RTU, CD Bus | 5 | |
| N° 1 EtherCAT®, n° 1 Modbus® TCP, n°3 Modbus® RTU, CD Bus | 6 | |
| N° 1 Ethernet IP, n° 1 Modbus® TCP, n°3 Modbus® RTU, CD Bus | 7 | |

| | | |
|---------------|-----|------|
| MANUAL | 15 | |
| Description | cod | note |
| None | 0 | |
| Italian | 1 | |
| English | 2 | |
| German | 3 | |
| French | 4 | |

| | | |
|---|-----|------|
| Aux Voltage to be coupled with an external transformer | 11 | |
| Description | cod | note |
| 24Vdc | 4 | |

| | | |
|----------------|-----|------|
| VERSION | 16 | |
| Description | cod | note |
| Version 2 | 2 | |

Connection example

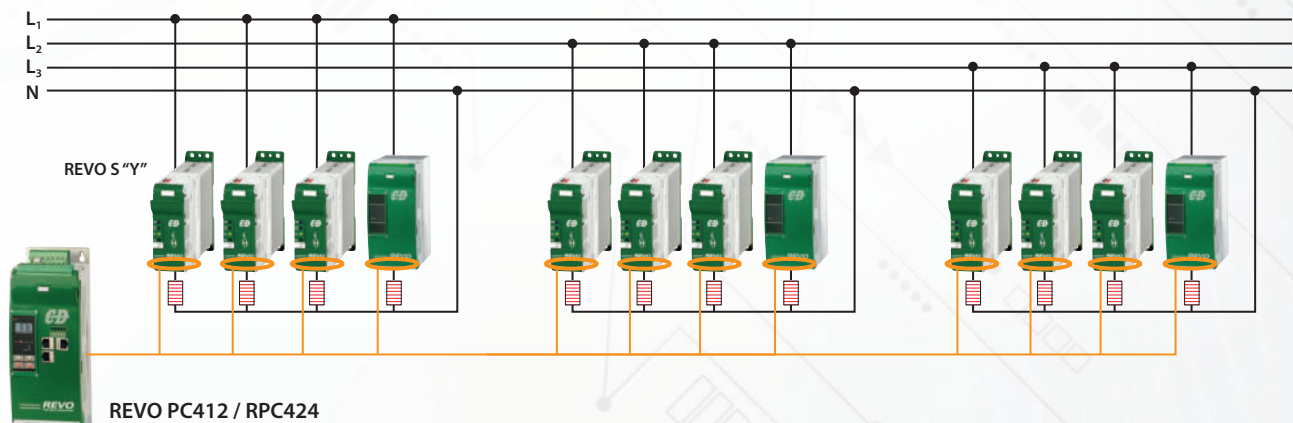

RPC 2

Three-phase system regulated on two legs STAR WITHOUT NEUTRAL OR CLOSE DELTA CONNECTION

| | | | | | | | | | | | | | | | | | |
|-------------------|---|---|---|---|---|---|---|---|---|---|----|----|----|----|----|----|----|
| REVO PC | 1 | 2 | 3 | 4 | 5 | 6 | | 7 | 8 | 9 | 10 | 11 | 12 | 13 | 14 | 15 | 16 |
| ORDER CODE | R | P | C | - | - | - | - | - | - | - | - | - | - | - | - | - | - |

| CHANNELS | 4 | 5 | 6 | |
|---|---|-----|---|------|
| Description | | cod | | note |
| REVO-PC to drive N°4 of 3 Phase Loads with two legs (2PH) N°8 SSR output to drive N°8 REVO S 1PH | 2 | 0 | 4 | |
| REVO-PC to drive N°8 of 3 Phase Loads with two legs (2PH) N°16 SSR output to drive N°16 REVO S 1PH | 2 | 0 | 8 | |

| CURRENT SENSOR INPUT | 7 | 8 | 9 | |
|---|---|---|---|--------------|
| Description | | | | cod note |
| N°3 Current Sensor Input for each three phase channel are required. Current Sensor is included and integrated with REVO S 1PH units with "Y" Option. | | | | |
| For 2PH control N°2 REVO S 1PH units with "Y" option are required + an additional Current Transformer | | | | See CT Table |

| COMMUNICATION | 10 | |
|---|----|----------|
| Description | | cod note |
| N°1 Modbus® TCP, n°3 Modbus® RTU, CD Bus | 1 | |
| N°1 Profibus-DP® port, Modbus TCP, Modbus RTU, CD Bus (with external module) <i>on request only</i> | 4 | |
| N°1 ProfiNet®, n° 1 Modbus® TCP, n°3 Modbus® RTU, CD Bus | 5 | |
| N° 1 EtherCAT, n° 1 Modbus® TCP, n°3 Modbus® RTU, CD Bus | 6 | |
| N° 1 Ethernet IP, n° 1 Modbus® TCP, n°3 Modbus® RTU, CD Bus | 7 | |

| Aux Voltage to be coupled with an external transformer | 11 | |
|--|----|----------|
| Description | | cod note |
| 24Vdc | 4 | |

| FIRING | 12 | |
|-------------------------------|----|----------|
| Description | | cod note |
| One Cycle at 50% power demand | 2 | |

| FEED BACK (Control Mode) | 13 | |
|--------------------------|----|----------|
| Description | | cod note |
| No Feedback | 1 | |
| Power | 2 | |

| APPROVALS | 14 | |
|------------------------|----|----------|
| Description | | cod note |
| CE for European market | 1 | |
| CE + cUL (pending) | L | |

| MANUAL | 15 | |
|--------------------|----|----------|
| Description | | cod note |
| None | 0 | |
| Italian | 1 | |
| English | 2 | |
| German | 3 | |
| French | 4 | |

| VERSION | 16 | |
|--------------------|----|----------|
| Description | | cod note |
| Version 2 | 2 | |

CT for the third uncontrolled phase

MANDATORY *

| External current sensor | | | | | |
|-------------------------|-------------|-----|-------------|-------------|-----|
| Description | REVO S size | cod | Description | REVO S size | cod |
| 50/0,05 | 30-40A | 000 | 200/0,05 | 150-200A | 004 |
| 75/0,05 | 60A | 001 | 250/0,05 | 210A | 005 |
| 100/0,05 | 90A | 002 | 400/0,05 | 300-400A | 006 |
| 150/0,05 | 120A | 003 | 800/0,2 | 500-800A | 007 |

Connection example

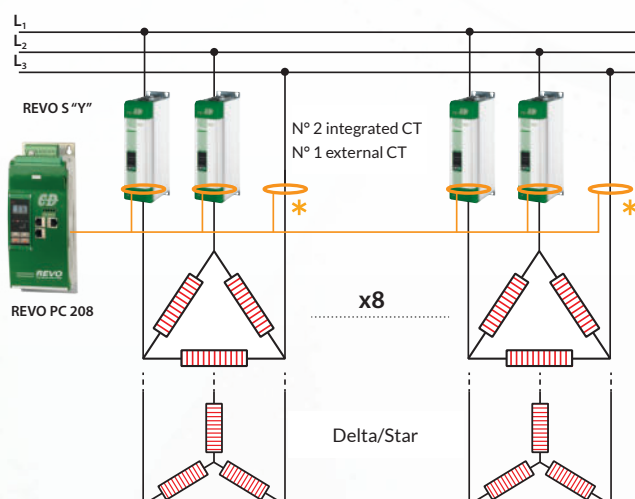

RPC 3

Three-phase system regulated on three legs

STAR + NEUTRAL CONNECTION

| | | | | | | | | | | | | | | | | |
|-------------------|---|---|---|---|---|---|---|---|---|----|----|----|----|----|----|----|
| REVO PC | 1 | 2 | 3 | 4 | 5 | 6 | 7 | 8 | 9 | 10 | 11 | 12 | 13 | 14 | 15 | 16 |
| ORDER CODE | R | P | C | - | - | - | - | - | - | - | - | - | - | - | - | - |

| CHANNELS | 4 | 5 | 6 |
|---|-----|------|---|
| Description | cod | note | |
| REVO-PC to drive N°4 of 3 Phase Loads with three legs (3PH) N°12 SSR output to drive N°12 REVO S 1PH | 3 | 0 | 4 |
| REVO-PC to drive N°8 of 3 Phase Loads with three legs (3PH) N°24 SSR output to drive N°24 REVO S 1PH | 3 | 0 | 8 |

| CURRENT SENSOR INPUT | 7 | 8 | 9 |
|--|-----|------|---|
| Description | cod | note | |
| N°3 Current Sensor Input for each three phase channel are required. | 0 | 0 | 0 |
| Current Sensor is included and integrated with REVO S 1PH units with "Y" Option. | | | |

| COMMUNICATION | 10 |
|---|-----|
| Description | cod |
| N°1 Modbus® TCP, n°3 Modbus® RTU, CD Bus | 1 |
| N°1 Profibus-DP® port, Modbus TCP, Modbus RTU, CD Bus (with external module) <i>on request only</i> | 4 |
| N°1 ProfiNet®, n° 1 Modbus® TCP, n°3 Modbus® RTU, CD Bus | 5 |
| N° 1 EtherCAT, n° 1 Modbus® TCP, n°3 Modbus® RTU, CD Bus | 6 |
| N° 1 Ethernet IP, n° 1 Modbus® TCP, n°3 Modbus® RTU, CD Bus | 7 |

| Aux Voltage to be coupled with an external transformer | 11 |
|--|-----|
| Description | cod |
| 24Vdc | 4 |

| FIRING | 12 |
|--------------------------------|-----|
| Description | cod |
| Half Cycle (only with neutral) | 1 |
| One Cycle at 50% power demand | 2 |

| FEED BACK (Control Mode) | 13 |
|--------------------------|-----|
| Description | cod |
| No Feedback | 1 |
| Power | 2 |

| APPROVALS | 14 |
|------------------------|-----|
| Description | cod |
| CE for European market | 1 |
| CE + cUL (pending) | L |

| MANUAL | 15 |
|-------------|-----|
| Description | cod |
| None | 0 |
| Italian | 1 |
| English | 2 |
| German | 3 |
| French | 4 |

| VERSION | 16 |
|-------------|-----|
| Description | cod |
| Version 2 | 2 |

Connection example

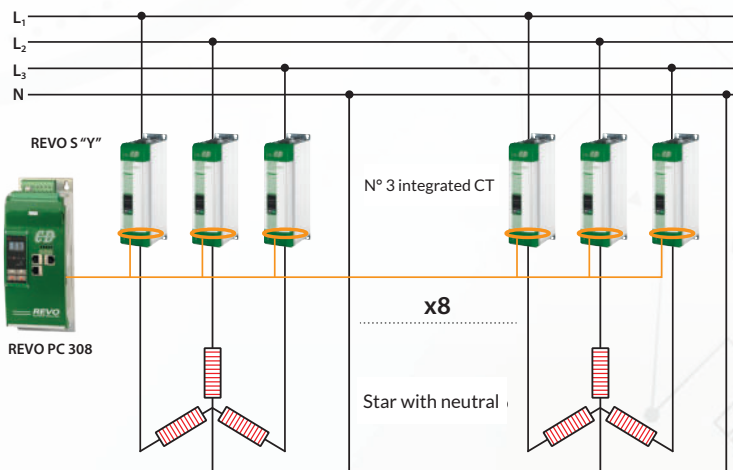

Codice TA

| External current sensor | | | | | |
|-------------------------|-------------|-----|-------------|-------------|-----|
| Description | REVO S size | cod | Description | REVO S size | cod |
| 50/0,05 | 30-40A | 000 | 200/0,05 | 150-200A | 004 |
| 75/0,05 | 60A | 001 | 250/0,05 | 210A | 005 |
| 100/0,05 | 90A | 002 | 400/0,05 | 300-400A | 006 |
| 150/0,05 | 120A | 003 | 800/0,2 | 500-800A | 007 |

REVO S selection for REVO PC

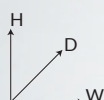
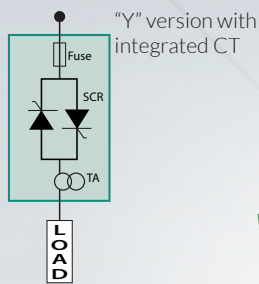

| | | | | | |
|----------------------|----------------------|----------------------|-----------------------|-----------------------|-----------------------|
| SR6 | SR12 | SR15 | S11 | S12 | S15 |
| H 121 x W 36 x D 185 | H 269 x W 93 x D 170 | H 273 x W 93 x D 170 | H 440 x W 137 x D 270 | H 520 x W 137 x D 270 | H 560 x W 137 x D 270 |
| 0,61 kg | 3,4kg | 3,6 kg | 10,5 kg | 15 kg | 17,2kg |

| | | | | | | | | | | | | | | | | |
|-------------------|----------|----------|----------|----------|----------|----------|----------|----------|----------|-----------|-----------|-----------|-----------|-----------|-----------|-----------|
| REVO S 1PH | 1 | 2 | 3 | 4 | 5 | 6 | 7 | 8 | 9 | 10 | 11 | 12 | 13 | 14 | 15 | 16 |
| ORDER CODE | R | S | 1 | - | - | - | - | - | - | - | - | Y | - | - | - | - |

| CURRENT | | 4 | 5 | 6 | |
|----------------|---------------|-----------|-------|------|--|
| Description | Size 480/600V | Size 690V | cod | note | |
| 30A | SR3 / IFH=SR6 | -- | 0 3 0 | | |
| 35A | SR3 / IFH=SR6 | -- | 0 3 5 | | |
| 40A | SR3 / IFH=SR6 | -- | 0 4 0 | | |
| 60A | SR12 | S11 | 0 6 0 | | |
| 90A | SR15 | S11 | 0 9 0 | | |
| 120A | SR15 | S11 | 1 2 0 | | |
| 150A | SR15 | S11 | 1 5 0 | | |
| 180A | SR15 | S11 | 1 8 0 | | |
| 210A | SR15 | S11 | 2 1 0 | | |
| 300A | S12 | S12 | 3 0 0 | | |
| 400A | S12 | S12 | 4 0 0 | | |
| 500A | S12 | S12 | 5 0 0 | | |
| 600A | S12 | S12 | 6 0 0 | | |
| 700A | S12 | S12 | 7 0 0 | | |
| 800A | S15 | S15 | 8 0 0 | 1 | |

| MAX VOLTAGE | | 7 | |
|--------------------|--|-----|------|
| Description | | cod | note |
| 480V | | 4 | |
| 600V | | 6 | |
| 690V | | 7 | 2 |

| VOLTAGE SUPPLY AUX | | 8 | |
|---------------------------|-------------------|-----|------|
| ≤ 210A | | cod | note |
| No Aux | | 0 | |
| ≥ 300A | | | |
| Main Supply Voltage | Aux Voltage Range | | |
| 100/120Vac | 90÷135Vac | 1 | 3 |
| 200/208/230/240Vac | 180÷265Vac | 2 | 3 |
| 277Vac | 238÷330Vac | 3 | 3 |
| 380/415/480Vac | 342÷528Vac | 5 | 3 |
| 600Vac | 540÷759Vac | 6 | 3 |
| 690Vac | 540÷759Vac | 7 | 3 |

| INPUT | | 9 | |
|---------------------------------|--|-----|------|
| Description | | cod | note |
| SSR "Y" to connect with REVO PC | | S | |

| FIRING | | 10 | |
|---------------|--|-----|------|
| Description | | cod | note |
| Zero Crossing | | Z | |

| CONTROL MODE | | 11 | |
|---------------------|--|-----|------|
| Description | | cod | note |
| Open Loop | | 0 | |

| FUSES & OPTION | | 12 | |
|---|--|-----|------|
| 30-40A | | cod | note |
| Extrarapid fuse + fuse holder + integrated CT | | Y | |
| 60-800A | | | |
| Extrarapid fixed fuses + integrated CT | | Y | |

| FAN VOLTAGE | | 13 | |
|---------------------------|--|-----|------|
| Description | | cod | note |
| No fan < 90A | | 0 | |
| Fan 115Vac ≥ 90A | | 1 | |
| Fan 230Vac ≥ 90A Standard | | 2 | |
| Fan 24Vdc ≥ 90A | | 3 | |

| APPROVALS | | 14 | |
|------------------------|--|-----|------|
| Description | | cod | note |
| CE for European market | | 0 | |
| CE + cUL | | L | 1 |

| MANUAL | | 15 | |
|---------------|--|-----|------|
| Description | | cod | note |
| None | | 0 | |
| Italian | | 1 | |
| English | | 2 | |
| German | | 3 | |
| French | | 4 | |

| VERSION | | 16 | |
|---------------------------------|--|-----|------|
| Description | | cod | note |
| Standard version with CT output | | 1 | |

Note 1: UL option (not cUL) for 800A units **Note 2:** Available in units ≥60A, 690V units are available with CE only
Note 3: Load voltage must be included in Selected Auxiliary Voltage Range for units ≥300A

REVO SX 1PH Multichannel Unit for REVO PC

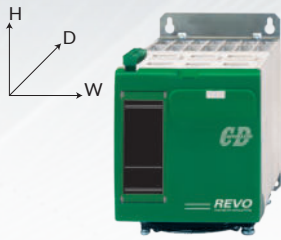

SR25

H 180xW 116xD 183 - 2,35 kg

“Y” version
with Current
transformer (CT)

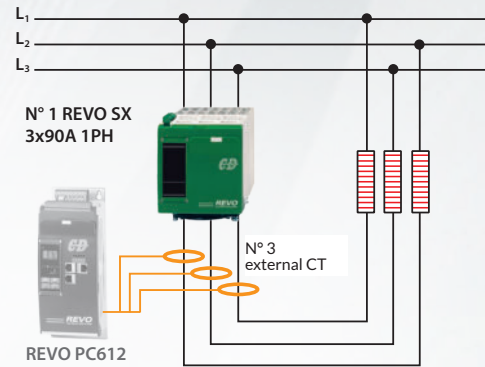

| REVO SX | 1 | 2 | 3 | 4 | 5 | 6 | 7 | 8 | 9 | 10 | 11 | 12 | 13 | 14 | 15 | 16 |
|-------------------|---|---|---|---|---|---|---|---|---|----|----|----|----|----|----|----|
| ORDER CODE | R | S | X | - | - | - | - | - | - | - | - | - | - | - | - | - |

| NUMBER OF ZONES X CURRENT RATING | 4 | 5 | 6 | |
|----------------------------------|-------|------|---|--|
| Description | cod | note | | |
| 2 zones 50A each | 2 5 0 | | | |
| 2 zones 60A each | 2 6 0 | | | |
| 2 zones 75A each | 2 7 5 | | | |
| 2 zones 90A each | 2 9 0 | | | |
| 3 zones 50A each | 3 5 0 | | | |
| 3 zones 60A each | 3 6 0 | | | |
| 3 zones 75A each | 3 7 5 | | | |
| 3 zones 90A each | 3 9 0 | | | |

| MAX VOLTAGE | 7 | |
|-------------|-----|------|
| Description | cod | note |
| 480V | 4 | |
| 600V | 6 | |

| VOLTAGE SUPPLY AUX | 8 | |
|----------------------|-----|------|
| Description | cod | note |
| No Auxiliary Voltage | 0 | |

| INPUT | 9 | |
|---------------------------------|-----|------|
| Description | cod | note |
| SSR “Y” to connect with REVO PC | S | |

| FIRING | 10 | |
|---------------|-----|------|
| Description | cod | note |
| Zero Crossing | Z | |

| CONTROL MODE | 11 | |
|--------------|-----|------|
| Description | cod | note |
| Open Loop | 0 | |

| FUSES & OPTION | 12 | |
|-----------------------------|-----|------|
| Description | cod | note |
| Extrarapid fixed fuses + CT | Y | |

| FAN VOLTAGE | 13 | |
|---------------------|-----|------|
| Description | cod | note |
| Standard: fan 24Vdc | 3 | |

| APPROVALS | 14 | |
|------------------------|-----|------|
| Description | cod | note |
| CE for European market | 0 | |

| MANUAL | 15 | |
|-------------|-----|------|
| Description | cod | note |
| None | 0 | |
| Italian | 1 | |
| English | 2 | |
| German | 3 | |
| French | 4 | |

| VERSION | 16 | |
|-------------|-----|------|
| Description | cod | note |
| Version 1 | 1 | |

Operator panels

KP - User interface

The KP user interface is designed to be connected to a single unit via RS485. It can be connected to most units including REVO C, REVEX, REVO RT, REVO PN.

Parameters like power, current and alarms, and other operator functions can be read on the display. Local/Remote, Up and Down and Function commands are also available.

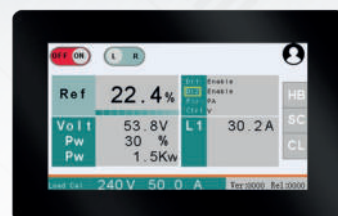

| | 1 | 2 | 3 | 4 | 5 | 6 | 7 | 8 | 9 | 10 | 11 | 12 | 13 | 14 | 15 | 16 | |
|---|---|---|---|-----|---|---|-----|---|---|----|----|-----|----|----|----|----|--|
| ORDER CODE | K | P | - | - | - | - | - | - | - | - | - | - | 0 | 0 | 0 | 0 | |
| VERSION | | | | 3 | 4 | | | | | | | | | | | | |
| Description | | | | cod | | | | | | | | | | | | | |
| Operative Display for REVO C and REVEX Series | | | | R | C | | | | | | | | | | | | |
| Operative Display for REVO PN | | | | P | N | | | | | | | | | | | | |
| Operative Display for REVO RT | | | | R | T | | | | | | | | | | | | |
| Screen size | | | | 5 | 6 | | | | | | | | | | | | |
| Description | | | | cod | | | | | | | | | | | | | |
| 4.3" horizontal | | | | H | 4 | | | | | | | | | | | | |
| 7" horizontal | | | | H | 7 | | | | | | | | | | | | |
| COMMUNICATION | | | | | | | 7 | 8 | 9 | 10 | | | | | | | |
| Description | | | | | | | cod | | | | | | | | | | |
| MODBUS RTU | | | | | | | M | 0 | 0 | 0 | | | | | | | |
| APPROVALS | | | | | | | | | | | | 11 | 12 | | | | |
| Description | | | | | | | | | | | | cod | | | | | |
| CE for European market | | | | | | | | | | | | 0 | 0 | | | | |

REVO KP3

The REVO KP3 touch panel is configured to communicate with the REVO C and REVEX series SSRs.

It can be connected to up to 6 zones and all the main parameters of the six zones can be displayed on one page. Each parameter can be recorded and it is possible to see the trend and history of the recorded variables in real time.

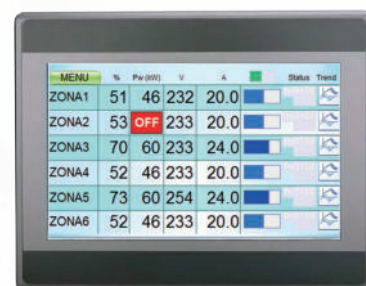

| | 1 | 2 | 3 | 4 | 5 | 6 | 7 | 8 | 9 | 10 | | |
|--------------------------------|---|---|---|---|---|-----|-----|-----|-----|----|--|--|
| ORDER CODE | R | K | P | - | - | - | - | - | - | - | | |
| VERSION | | | | | | 4 | | | | | | |
| Description | | | | | | cod | | | | | | |
| Version 3 for REVO C and REVEX | | | | | | 3 | | | | | | |
| Screen size | | | | | | 5 | 6 | | | | | |
| Description | | | | | | cod | | | | | | |
| 4.3" | | | | | | 0 | 4 | | | | | |
| 7.0" | | | | | | 0 | 7 | | | | | |
| 10.0" | | | | | | 1 | 0 | | | | | |
| COMMUNICATION | | | | | | | 7 | 8 | | | | |
| Description | | | | | | | cod | | | | | |
| MODBUS RTU + Ethernet | | | | | | | M | ETH | | | | |
| APPROVALS | | | | | | | | | 9 | 10 | | |
| Description | | | | | | | | | cod | | | |
| CE for European market | | | | | | | | | 0 | 0 | | |
| CE + UL | | | | | | | | | U | L | | |

Customised panels are possible. Please contact our technical department for more information.

Communication modules



TU-RS485-TCP-3580MB
Modbus/TCP - Modbus RTU converter



TU-RS485-ETH-000000
Serial Ethernet - Datalogger converter



TU-RS485-PNT-067602
Profinet terminal unit



TU-RS485-EIP-067591
Ethernet/IP / Modbus Master converter



RS485 | TU-RS485-232-00Z107
RS232 converter

| | 1 | 2 | | 3 | 4 | 5 | 6 | 7 | | 8 | 9 | 10 | | 11 | 12 | 13 | 14 | 15 | 16 | |
|---|---|---|---|---|---|---|---|---|---|---|---|----|---|----|----|----|----|----|----|---|
| ORDER CODE | T | U | - | R | S | 4 | 8 | 5 | - | - | - | - | - | - | - | - | - | - | - | |
| COMMUNICATION | | | | 3 | 4 | 5 | 6 | 7 | | | | | | | | | | | | |
| Modbus RTU | | | | R | S | 4 | 8 | 5 | | | | | | | | | | | | |
| FIELDBUS, COMMUNICATION OR OTHER FUNCTIONS | | | | | | | | | | 8 | 9 | 10 | | 11 | 12 | 13 | 14 | 15 | 16 | |
| Modbus TCP Protocol Converter | | | | | | | | | | - | T | C | P | - | 3 | 5 | 8 | 0 | M | B |
| Modbus TCP, Modbus Slave, IO, Data Logger, Logic | | | | | | | | | | - | E | T | H | - | 0 | 0 | 0 | 0 | 0 | 0 |
| Profinet | | | | | | | | | | - | P | N | T | - | 0 | 6 | 7 | 6 | 0 | 2 |
| Ethernet IP | | | | | | | | | | - | E | I | P | - | 0 | 6 | 7 | 5 | 9 | 1 |
| RS232 | | | | | | | | | | - | 2 | 3 | 2 | - | 0 | 0 | Z | 1 | 0 | 7 |

Features comparison

| | | BASIC PRODUCTS WITHOUT COMMUNICATION | | | UNIVERSAL |
|--------------|--|--------------------------------------|-------------------|-------------------|----------------|
| DESCRIPTION | | REVO S 1PH | REVO S 2PH | REVO S 3PH | REVEX 1PH |
| CODE | | RS1 | RS2 | RS3 | RX1 |
| MAIN VOLTAGE | Max voltage 480V | ● | ● | ● | ● |
| | Max voltage 600V | ● | ● | ● | ● |
| | Max voltage 690V (1) | ● | ● | ● | ● |
| LOAD TYPE | Single phase | ● | | | ● |
| | 3 phase load star no neutral or delta | | ● | ● | |
| | 3 phase load star with neutral | | | ● | |
| | 3 phase load open delta | | | ● | |
| INPUT | SSR 4:30VDC | ● | ● | ● | ● |
| | 4:20 mA | ○ | ○ | ○ | ● |
| | 0:10 Vdc | ○ | ○ | ○ | ● |
| | Potentiometer | ○ | ○ | ○ | ● |
| FIRING | Zero Crossing | ● | ● | ● | ● |
| | Half Cycle | | | | ● |
| | Single Cycle | | | | ● |
| | Burst Firing | | | | ● |
| | Burst Firing simplified 4-8-16 Cycles at 50% (2) | ● | ● | ● | ● |
| | Delayed triggering | | | | ● |
| | Phase Angle | | | | ● |
| | Soft Start | | | | ● |
| CONTROL MODE | No Feed Back | ● | ● | ● | ● |
| | Voltage | | | | ● |
| | Voltage Square | | | | ● |
| | Current | | | | ● |
| | Current Square | | | | ● |
| | Power Vxl | | | | ● |
| | Transfer from V to Vxl or I to Vxl | | | | ○ |
| OPTION | Current Limit | | | | ● |
| | Heater Break - HB Alarm | ○ | ○ | ○ | ● |
| | Logging (Data Logger) | | | | |
| | Totalizer (Energy) | | | | |
| TOOLS | Smartphone App (free) | | | | |
| | Software PC Configurator (Line analyzer free) | | | | ● |
| COMMUNIC. | Bluetooth | | | | |
| | N°1 Modbus® RTU | | | | ● |
| | N°2 Modbus® RTU | | | | ○ |
| | N°1 Profibus DP + N°1 Modbus® RTU | | | | ○ |
| | N°1 Profinet® + N°1 Modbus® RTU | | | | ○ |
| | N°1 Modbus® TCP + N°1 Modbus® RTU | | | | ○ |
| CURRENT | DESCRIPTION | REVO S 1PH | REVO S 2PH | REVO S 3PH | REVEX 1PH |
| | Size/Approvals | Size/Approvals | Size/Approvals | Size/Approvals | Size/Approvals |
| | 30 | SR3-SR6/CE-cUL | SR4-SR7/CE-cUL | SR5-SR8/CE-cUL | SR6/CE |
| | 35 | SR3-SR6/CE-cUL | SR4-SR7/CE-cUL | SR5-SR8/CE-cUL | SR6/CE |
| | 40 | SR3-SR6/CE-cUL | SR4-SR7/CE-cUL | SR5-SR8/CE-cUL | SR6/CE |
| | 60 | SR12/CE-cUL (3) | F/SR15/CE-cUL (3) | F/SR16/CE-cUL (3) | SR24/CE |
| | 75 | | F/SR15/cUL | F/SR16/cUL | |
| | 90 | F/SR15/CE-cUL (3) | F/SR15/CE (3) | F/SR16/CE (3) | F/SR24/CE |
| | 120 | F/SR15/CE-cUL (3) | F/SR16/CE-cUL (4) | F/SR17/CE-cUL (4) | F/SR15/CE |
| | 150 | F/SR15/CE-cUL (3) | F/SR16/CE-cUL (4) | F/SR17/CE-cUL (4) | F/SR15/CE |
| | 180 | F/SR15/CE-cUL (3) | F/SR16/CE-cUL (4) | F/SR17/CE-cUL (4) | F/SR15/CE |
| | 210 | F/SR15/CE-cUL (3) | F/SR16/CE-cUL (4) | F/SR17/CE-cUL (4) | F/SR15/CE |
| | 280 | F/S10/CE | F/2xS10/CE | | F/S10/CE |
| | 300 | F/S12/CE-cUL | F/S14/CE-cUL | F/S14/CE-cUL | |
| | 350 | | | F/S14/CE-cUL | |
| | 400 | F/S12/CE-cUL | F/S14/CE-cUL | F/S14/CE-cUL | |
| | 450 | | F/S14/CE-cUL | F/S14/CE-cUL | |
| | 500 | F/S12/CE-cUL | F/S14/CE-cUL | F/S14/CE-cUL | |
| | 600 | F/S12/CE-cUL | F/S14/CE-cUL | | |
| | 700 | F/S12/CE-cUL | F/S14/CE-cUL | | |
| | 800 | F/S15/CE | F/S16/CE | F/S17/CE | |
| 1100 | | | | | |
| 1400 | | | | | |
| 1600 | | | | | |
| 1800 | | | | | |
| 2100 | | | | | |

● STANDARD ○ OPTION F: Fan Air Cooling; any letter before SIZE: Natural Air Cooling (1) cUL® Approval is for Voltage ≤ 600V

thyristor unit SINGLE LOOP

| THYRISTOR UNITS FULLY CONFIGURATION WITH COMMUNICATION | | | | | DESCRIPTION | |
|--|--------------------------|--------------------------|--------------------------|--------------------------|--|--------------|
| REVEX 2PH | REVEX 3PH | REVO C 1PH | REVO C 2PH | REVO C 3PH | DESCRIPTION | |
| RX2 | RX3 | RC1 | RC2 | RC3 | CODE | |
| <input type="checkbox"/> | <input type="checkbox"/> | <input type="checkbox"/> | <input type="checkbox"/> | <input type="checkbox"/> | Max voltage 480V | MAIN VOLTAGE |
| <input type="checkbox"/> | <input type="checkbox"/> | <input type="checkbox"/> | <input type="checkbox"/> | <input type="checkbox"/> | Max voltage 600V | |
| <input type="checkbox"/> | <input type="checkbox"/> | <input type="checkbox"/> | <input type="checkbox"/> | <input type="checkbox"/> | Max voltage 690V (1) | |
| <input type="checkbox"/> | <input type="checkbox"/> | <input type="checkbox"/> | <input type="checkbox"/> | <input type="checkbox"/> | Single phase | LOAD TYPE |
| <input type="checkbox"/> | <input type="checkbox"/> | <input type="checkbox"/> | <input type="checkbox"/> | <input type="checkbox"/> | 3 phase load star no neutral or delta | |
| <input type="checkbox"/> | <input type="checkbox"/> | <input type="checkbox"/> | <input type="checkbox"/> | <input type="checkbox"/> | 3 phase load star with neutral | |
| <input type="checkbox"/> | <input type="checkbox"/> | <input type="checkbox"/> | <input type="checkbox"/> | <input type="checkbox"/> | 3 phase load open delta | |
| <input type="checkbox"/> | <input type="checkbox"/> | <input type="checkbox"/> | <input type="checkbox"/> | <input type="checkbox"/> | SSR 4:30VDC | INPUT |
| <input type="checkbox"/> | <input type="checkbox"/> | <input type="checkbox"/> | <input type="checkbox"/> | <input type="checkbox"/> | 4:20 mA | |
| <input type="checkbox"/> | <input type="checkbox"/> | <input type="checkbox"/> | <input type="checkbox"/> | <input type="checkbox"/> | 0:10 Vdc | |
| <input type="checkbox"/> | <input type="checkbox"/> | <input type="checkbox"/> | <input type="checkbox"/> | <input type="checkbox"/> | Potentiometer | |
| <input type="checkbox"/> | <input type="checkbox"/> | <input type="checkbox"/> | <input type="checkbox"/> | <input type="checkbox"/> | Zero Crossing | FIRING |
| <input type="checkbox"/> | <input type="checkbox"/> | <input type="checkbox"/> | <input type="checkbox"/> | <input type="checkbox"/> | Half Cycle | |
| <input type="checkbox"/> | <input type="checkbox"/> | <input type="checkbox"/> | <input type="checkbox"/> | <input type="checkbox"/> | Single Cycle | |
| <input type="checkbox"/> | <input type="checkbox"/> | <input type="checkbox"/> | <input type="checkbox"/> | <input type="checkbox"/> | Burst Firing | |
| <input type="checkbox"/> | <input type="checkbox"/> | <input type="checkbox"/> | <input type="checkbox"/> | <input type="checkbox"/> | Burst Firing simplified 4-8-16 Cycles at 50% (2) | |
| <input type="checkbox"/> | <input type="checkbox"/> | <input type="checkbox"/> | <input type="checkbox"/> | <input type="checkbox"/> | Delayed Triggering | |
| <input type="checkbox"/> | <input type="checkbox"/> | <input type="checkbox"/> | <input type="checkbox"/> | <input type="checkbox"/> | Phase Angle | CONTROL MODE |
| <input type="checkbox"/> | <input type="checkbox"/> | <input type="checkbox"/> | <input type="checkbox"/> | <input type="checkbox"/> | Soft Start | |
| <input type="checkbox"/> | <input type="checkbox"/> | <input type="checkbox"/> | <input type="checkbox"/> | <input type="checkbox"/> | No Feed Back | |
| <input type="checkbox"/> | <input type="checkbox"/> | <input type="checkbox"/> | <input type="checkbox"/> | <input type="checkbox"/> | Voltage | |
| <input type="checkbox"/> | <input type="checkbox"/> | <input type="checkbox"/> | <input type="checkbox"/> | <input type="checkbox"/> | Voltage Square | |
| <input type="checkbox"/> | <input type="checkbox"/> | <input type="checkbox"/> | <input type="checkbox"/> | <input type="checkbox"/> | Current | |
| <input type="checkbox"/> | <input type="checkbox"/> | <input type="checkbox"/> | <input type="checkbox"/> | <input type="checkbox"/> | Current Square | OPTION |
| <input type="checkbox"/> | <input type="checkbox"/> | <input type="checkbox"/> | <input type="checkbox"/> | <input type="checkbox"/> | Power Vxl | |
| <input type="checkbox"/> | <input type="checkbox"/> | <input type="checkbox"/> | <input type="checkbox"/> | <input type="checkbox"/> | Transfer from V to Vxl or I to Vxl | |
| <input type="checkbox"/> | <input type="checkbox"/> | <input type="checkbox"/> | <input type="checkbox"/> | <input type="checkbox"/> | Current Limit | |
| <input type="checkbox"/> | <input type="checkbox"/> | <input type="checkbox"/> | <input type="checkbox"/> | <input type="checkbox"/> | Heater Break - HB Alarm | |
| <input type="checkbox"/> | <input type="checkbox"/> | <input type="checkbox"/> | <input type="checkbox"/> | <input type="checkbox"/> | Logging (Data Logger) | |
| <input type="checkbox"/> | <input type="checkbox"/> | <input type="checkbox"/> | <input type="checkbox"/> | <input type="checkbox"/> | Totalizer (Energy) | TOOLS |
| <input type="checkbox"/> | <input type="checkbox"/> | <input type="checkbox"/> | <input type="checkbox"/> | <input type="checkbox"/> | Smartphone App (free) | |
| <input type="checkbox"/> | <input type="checkbox"/> | <input type="checkbox"/> | <input type="checkbox"/> | <input type="checkbox"/> | Software PC Configurator (Line analyzer free) | COMMUNIC. |
| <input type="checkbox"/> | <input type="checkbox"/> | <input type="checkbox"/> | <input type="checkbox"/> | <input type="checkbox"/> | Bluetooth | |
| <input type="checkbox"/> | <input type="checkbox"/> | <input type="checkbox"/> | <input type="checkbox"/> | <input type="checkbox"/> | N°1 Modbus® RTU | |
| <input type="checkbox"/> | <input type="checkbox"/> | <input type="checkbox"/> | <input type="checkbox"/> | <input type="checkbox"/> | N°2 Modbus® RTU | |
| <input type="checkbox"/> | <input type="checkbox"/> | <input type="checkbox"/> | <input type="checkbox"/> | <input type="checkbox"/> | N°1 Profibus DP + N°1 Modbus® RTU | |
| <input type="checkbox"/> | <input type="checkbox"/> | <input type="checkbox"/> | <input type="checkbox"/> | <input type="checkbox"/> | N°1 Profinet® + N°1 Modbus® RTU | |
| <input type="checkbox"/> | <input type="checkbox"/> | <input type="checkbox"/> | <input type="checkbox"/> | <input type="checkbox"/> | N°1 Modbus® TCP + N°1 Modbus® RTU | CURRENT |
| REVEX 2PH | REVEX 3PH | REVO C 1PH | REVO C 2PH | REVO C 3PH | DESCRIPTION | |
| Size/Approvals | Size/Approvals | Size/Approvals | Size/Approvals | Size/Approvals | Size/Approvals | |
| SR9/CE | SR10/CE | SR9/CE | SR10/CE-cUL | SR11/CE-cUL | 30 | |
| SR9/CE | SR10/CE | SR9/CE-cUL | SR10/CE-cUL | SR11/CE-cUL | 35 | |
| SR9/CE | SR10/CE | SR9/CE-cUL | SR10/CE-cUL | SR11/CE-cUL | 40 | |
| SR25/CE | F/SR25/CE (6) | SR12/CE-cUL (3) | SR13/CE-cUL (3) | SR14/CE-cUL (3) | 60 | |
| | | | | | 75 | |
| F/SR25/CE | F/SR25/CE (6) | F/SR15/CE-cUL (3) | F/SR16/CE-cUL (3) | F/SR17/CE-cUL (3) | 90 | |
| F/SR16/CE | F/RS17/CE | F/SR15/CE-cUL (3) | F/SR16/CE-cUL (4) | F/SR17/CE-cUL (4) | 120 | |
| F/SR16/CE | F/RS17/CE | F/SR15/CE-cUL (3) | F/SR16/CE-cUL (4) | F/SR17/CE-cUL (4) | 150 | |
| F/SR16/CE | F/RS17/CE | F/SR15/CE-cUL (3) | F/SR16/CE-cUL (4) | F/SR17/CE-cUL (4) | 180 | |
| F/SR16/CE | F/RS17/CE | F/SR15/CE-cUL (3) | F/SR16/CE-cUL (4) | F/SR17/CE-cUL (4) | 210 | |
| F/2xS10/CE | | | | | 280 | |
| | | F/S12/CE-cUL | F/S14/CE-cUL | F/S14/CE-cUL | 300 | |
| | | | | | 350 | |
| | | F/S12/CE-cUL | F/S14/CE-cUL | F/S14/CE-cUL | 400 | |
| | | | F/S14/CE-cUL | F/S14/CE-cUL | 450 | |
| | | F/S12/CE-cUL | F/S14/CE-cUL | F/S14/CE-cUL | 500 | |
| | | F/S12/CE-cUL | F/S14/CE-cUL | F/S17/CE-UL | 600 | |
| | | F/S12/CE-cUL | F/S14/CE-cUL | F/S17/CE-UL | 700 | |
| | | F/S15/CE-UL | F/S16/CE-UL | F/S17/CE-UL | 800 | |
| | | F/SR18/CE-UL | F/SR19/CE-UL | F/SR20/CE-UL | 1100 | |
| | | F/SR21/CE-UL | F/SR22/CE-UL | F/SR23/CE-UL | 1400 | |
| | | F/SR21/CE-UL | F/SR22/CE-UL | F/SR23/CE-UL | 1600 | |
| | | F/SR21/CE-UL | F/SR22/CE-UL | F/SR23/CE-UL | 1800 | |
| | | F/SR21/CE-UL | F/SR22/CE-UL | F/SR23/CE-UL | 2100 | |

(2) It's possible just using Analog Input Ex. 4:20mA (3) Size S11 at 690V (no cUL) (4) Size S13 at 690V (no cUL) (5) Use n° 3 1PH units (6) from 2021 version

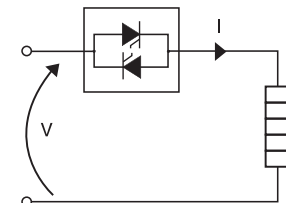
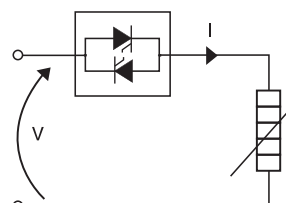
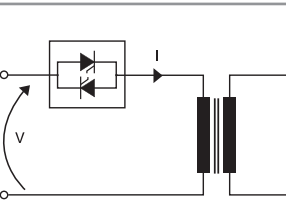
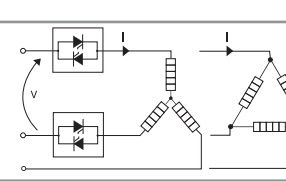
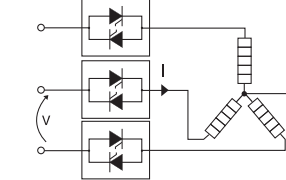
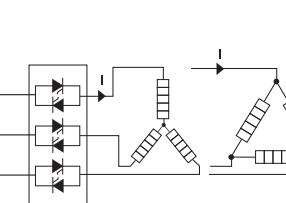
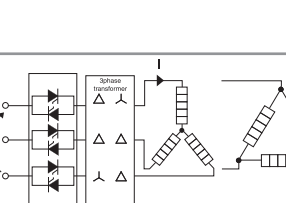
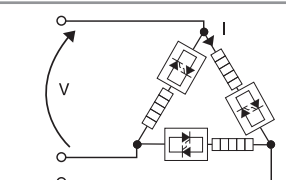
| APPLICATION GUIDE | LOAD TYPE | MODEL | CURRENT RANGE | N. OF UNITS | PHASE CTRL |
|---|--|------------|-------------------------|-------------|------------|
|  | Normal resistance infrared medium and long waveform | REVO SSR | It depends on heat sink | 1 | 1 |
| | | REVO S 1PH | 30-800A | 1 | 1 |
| | Quartz lamp infrared short waveform | REVO C 1PH | 30-2100A | 1 | 1 |
| | | REVE X 1PH | 30-280A | 1 | 1 |
|  | Molibdenum, Tungstenum, Kanthal® super, Platinum | REVE X 1PH | 30-280A | 1 | 1 |
| | | REVO C 1PH | 30-2100A | 1 | 1 |
| | Silicon carbide elements | REVO S 1PH | 30-800A | 1 | 1 |
| | | REVE X 1PH | 30-280A | 1 | 1 |
| | | REVO C 1PH | 30-2100A | 1 | 1 |
|  | Transformers coupled with normal resistance | REVE X 1PH | 30-280A | 1 | 1 |
| | | REVO C 1PH | 30-2100A | 1 | 1 |
| | Transformers coupled with cold resistances (Kanthal® super) | REVE X 1PH | 30-280A | 1 | 1 |
| | | REVO C 1PH | 30-2100A | 1 | 1 |
|  | Normal Resistance | REVO S 2PH | 30-800A | 1 | 2 |
| | | REVE X 2PH | 30-280A | 1 | 2 |
| | | REVO C 2PH | 30-2100A | 1 | 2 |
|  | Normal Resistance | REVO S 3PH | 30-500A | 1 | 3 |
| | | REVE X 3PH | 30-210A | 1 | 3 |
| | | REVO C 3PH | 30-2100A | 1 | 3 |
|  | Silicon carbide elements | REVO C 3PH | 60-2100A | 1 | 3 |
| | | REVE X PA | 35-90A | | |
| | Molibdenum, Tungstenum, Kantal® Super, Platinum, Quartz lamp infrared short waveform | REVO C 3PH | 60-2100A | 1 | 3 |
|  | Three phase transformer | REVO C 3PH | 60-2100A | 1 | 3 |
| | | REVE X PA | 35-90A | | |
|  | Three phase normal load resistance with open delta connection | REVO S 3PH | 30-800A | 1 | 3 |
| | | REVO C 1PH | 30-2100A | 3 | 3 |
| | Cold resistance | REVO C 1PH | 30-2100A | 3 | 3 |

CONTROL MODE:

V = Voltage feedback V² = Square voltage feedback VxI = Power feedback I = Current feedback

for thyristor unit SINGLE LOOP

| SUGGESTED FIRING MODE FOR YOUR APPLICATIONS | | | | | | OTHER FEATURES | | | | SIZING | | NOTE | |
|---|----|----|----|---------------|------|----------------|----|----|----------------|--------|-----------------------------|---|--|
| ZC | HC | SC | BF | BF Simplified | S+BF | DT | PA | CL | Control | V | I | | |
| • | | | | | | | | | | V | $\frac{P}{V}$ | For general resistance applications with low variations in temperature and age. For low inertia loads use Single Cycle (SC) or Phase Angle (PA). For Infrared Short it's suggested to use Half Cycle that is a very Fast Firing | |
| • | | | | • | | | | | | | | | |
| • | | | | • | | | | | | | | | |
| | • | • | | | | | | | V ² | | | | |
| | • | • | | | | | | • | | | | | |
| | | | | | | | | • | I ² | V | $\frac{P}{V}$ | These resistances change with temperature but have low variations with age. Starting current with cold elements can be 16 times nominal current (Kanthal® super). Infrared lamp short waveform can reach 8 time nominal current. | |
| | | | | | | | | • | | | | | |
| | | | • | | | | | • | V to Vxl | V | $\frac{P}{V}$ | These resistances change value with temperature and age and value at the end of element life is 4 times the initial value. Constant power regulation is necessary with V to Vxl Transfer. | |
| | | | | | | | • | | | | | | |
| | | | | | | | • | | Vxl | V | $\frac{P}{V \cos \phi}$ | Transformers and inductors have inrush current on start up. Phase Angle plus Soft Start and current limit are required. To switch the transformer ON-OFF, use DT firing that will automatically switch ON-OFF when current value is at zero. | |
| | | | | | | | | • | | | | | |
| | | | | | | | | • | I ² | V | $\frac{P}{V \cos \phi}$ | Use Phase Angle + Current Limit | |
| • | | | | • | | | | | | V | $\frac{P}{1.73V}$ | REVO S, REVE X and REVO C-2PH are suitable to control resistive loads with delta or star connection without neutral. | |
| | | | • | | | | | | | Vxl | $\frac{P}{1.73V}$ | | |
| | | | | | | | | | | | | | |
| • | | | | • | | | | | | | | | |
| | | | • | | | | | | | Vxl | $\frac{V}{1.73}$ | $\frac{P}{1.73V}$ | Three phase load with star plus neutral connection must be controlled on the three phases. |
| | | | • | | | | | | | | | | |
| | | | | | | | | | V to Vxl | V | $\frac{P}{1.73V}$ | On three phase silicon carbide elements Vxl feedback is suggested to have a constant power control. This is necessary to compensate resistance change with temperature and age. Resistance value at the end of element life is 4 times the original value. With REVO C use BF firing and Power Limit. | |
| | | | | | | | | • | | | | | |
| | | | | | | | | • | I ² | | | These resistances change with temperature but have low variations with age. Start up current with cold elements can be many times the nominal current value. In this case it is necessary to use Phase Angle + Current Limit. | |
| | | | | | | | | • | | | | | |
| | | | | | | | | • | I ² | V | $\frac{P}{1.73V \cos \phi}$ | Three phase REVO C units are specially designed to drive three phase transformers coupled on secondary with normal or special resistive loads. | |
| • | | | | • | | | | | | V | $\frac{P}{3V}$ | Open delta can be driven by three phase unit. | |
| | | | | | | | | • | I ² | | | | |
| | | | | | | | | • | | V | $\frac{P}{3V}$ | | |

Firing = BF Simplified 4-8-16 Cycles at 50% Power Demand with Analog Input only HC: Half Cycle SC: Single Cycle

At your service worldwide



Our sales and service network ensures worldwide distribution and support of our products.

Our locations



Headquarter and Production
Legnano (MI), Italy



CD Automation UK Ltd.
East Sussex, United Kingdom



M/s Toshcon CD Automation Pvt. Ltd.
Ajmer, India





Controllers, Drives & Automation

 Products made in Italy

Worldwide distribution and service

CD Automation Country Locations



CD Automation, a leader in the control of heating elements, has been offering top quality solutions in the field of industrial temperature control for over thirty years. The company supplies thyristor power units and SCR power controllers, making it the leading partner in the industry.

CD Automation offers a support service for the development, optimisation, sustainability and energy efficiency of thermal processes, improving plant power quality.

Our team will be at your disposal to deepen, analyse and optimise your applications.

Headquarter: Italia
CD Automation Srl
Via Picasso, 34/36
20025 Legnano MI - Italy
T +39 0331 577479
F +39 0331 579479
sales@cdautomation.com
www.cdautomation.com

United Kingdom
CD Automation UK Ltd.
Unit 9 Harvington Business Park
Brampton Road, Eastbourne
East Sussex, BN22 9BN - England
T +44 1323 811100
info@cdautomation.co.uk
www.cdautomation.co.uk

India
M/s Toshcon CD Automation Pvt. Ltd.
H1 - 75 Gegal Industrial Area
Ajmer - 305023 (Raj.) - India
T +91 145 2791112
T +91 145 6450601/2/3
sales.cd@toshcon.com
www.cdautomation.in