

# Motion Controllers

V2.5, 4-Quadrant PWM  
with RS232 or CAN interface

## MCBL 3002 S

Values at 22°C		MCBL 3002 S	
Power supply electronic	$U_B/U_{EL}$	8 ... 30	V DC
Power supply motor <sup>1)</sup>	$-U_B$	0 ... 30	V DC
PWM switching frequency	$f_{PWM}$	78,12	kHz
Efficiency electronic	$\eta$	95	%
Max. continuous output current	$I_{cont}$	2	A
Max. peak output current <sup>2)</sup>	$I_{max}$	3	A
Standby current for electronic (at $U_B=24V$ )	$I_{el}$	0,04	A
Operating temperature range		-25 ... +85	°C
Housing material		Hotmelt	
Mass		16	g

<sup>1)</sup> Only available for option 3085 (separate power supply)

<sup>2)</sup> S2 mode for max. 5s

Interfaces	MCBL 3002 S RS	MCBL 3002 S CO
Interface	RS232	CAN (CiA)
Protocol	FAULHABER - ASCII	CANopen

### Basic features

- Supported sensor systems: analog Hall sensors
- Positioning resolution when using analog Hall sensors as position encoder: 3000 increments per revolution
- Max. 3 digital inputs, max. 1 digital output, 1 analog input. Not all I/Os available depending on wiring
- Setpoint specification via fieldbus, quadrature signal, pulse and direction or analog inputs
- Optional stand-alone operation via application programs with the RS232 interface version

### Range of functions

Operating modes (RS Versions)	Position, speed and torque control with setpoint specification via interface or analog. Position control with Gearing Mode or stepper motor operation. Operation as Servo Amplifier in voltage controller mode
Operating modes (CO Version)	Profile Position Mode (PP), Profile Velocity Mode (PV), Homing Mode. Cyclic Synchronous Position Mode (CSP) acc. to IEC 61800-7-201 or IEC 61800-7-301.
Speed range for brushless motors with number of pole pairs 1	5 min <sup>-1</sup> ... 30 000 min <sup>-1</sup> (with sinus commutation)
Application programs	Available in versions with RS232 interface
Additional functions	Overload protection for electronics and motor, self-protection from overheating, over-voltage protection in generator mode.
Indicator	Trace as logger
Motor types	Brushless DC-motors with analog Hall sensors and number of pole pairs 1 or 2

### Dimensional drawing

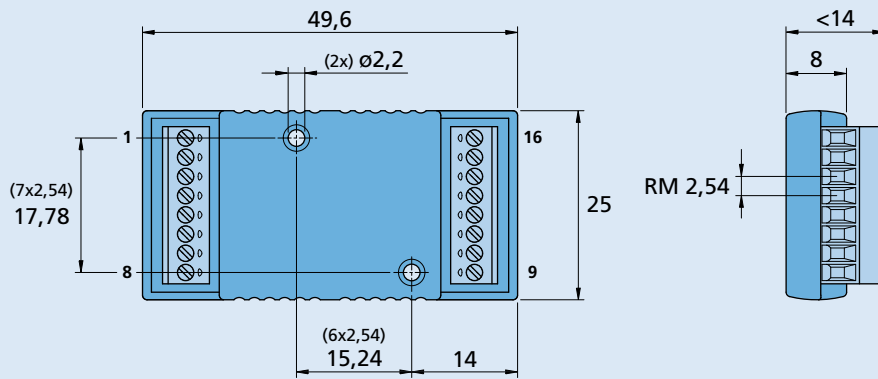

**MCBL 3002 S**

### Options and connection information

Example product designation: **MCBL 3002 S RS 3085**

Option	Type	Description	Connection	
			No. Function	No. Function
3085	Supply	Separate power supply for motor and electronics	1 TxD / CAN_H	9 Sensor A
			2 RxD / CAN_L	10 Sensor B
			3 AGND	11 Sensor C
			4 Fault	12 U <sub>cc</sub>
			5 AnIn	13 SGND
			6 U <sub>B</sub>	14 Motor A
			7 GND	15 Motor B
			8 3. In	16 Motor C

**Note:** For details on the connection assignment, see device manual MC.

### Product combination

Brushless DC-Motors	Cables / Accessories
1218 ... B 1226 ... B 1628 ... B 2036 ... B 2232 ... BX4 2250 ... BX4 2444 ... B 3056 ... B 3242 ... BX4	To view our large range of accessory parts, please refer to the „Accessories“ chapter.