

Digital Indicators • Data Loggers • Bus systems • Remote Inquiry • Temperature Probes • Alarm Protection Devices • Software • EASYBus • Sensors
pH / Redox / Conductivity • Flow/ Flowrate • Level / Fill Level • Material Moisture • Temperature • Oxygen • Humidity • Pressure • etc.

Industrial measurement 2012

MEASURING CONTROLLING REGULATING



GREISINGER

— electronic —



Greisinger electronic plant



Our EMC test laboratory

The GREISINGER electronic GmbH was founded in Regenstein on January 1, 1980 and has now been existing for over 30 years.

Our aim is the development and production of measuring and control equipment including suitable sensors.

Production occupies a working area of approx. 2250 m². 50 employees develop and produce our high-quality but for all that low priced devices using the most up-to-date development, production and inspection equipment.

The company owns a fully equipped screen cabin (5 x 3 x 2.5 m) where EMC tests are performed already during the development of new products.

Furthermore to mention is the 60 m² air-conditioned calibration lab for calibration and adjustment of e.g. temperature, pressure, humidity products.

For many applications, especially considering the ISO-9000ff documented measurings are necessary.

All our references can be traced back to national references and are permanently controlled.

Most of our products also can be ordered with Calibration or DKD Certificates to fulfill your quality requirements according to ISO9000.

Quality Standard and Certification



Fair prices and high-quality products have made us a company to be reckoned with on the measuring device sector. Our development has been steadily going upwards for the past 30 years. Globally operating and well-known companies are now amongst our regular customers.

All our products are developed and produced in Germany - the only way to ensure the high-quality standard of our products. Our quality management system is certified according to ISO 9001:2008 and additionally for potentially explosive atmospheres according to EN 13980:2002.

Products intended for use in explosive atmospheres have to comply the requirements of the Directive 94/9/EC („ATEX-directive“) since July 1.st 2003.

Development, production and marketing are certified according to Directive 94/9/EC since May 1.st 2003. Several products are already examined and certified according to the Directive 94/9/EC.



Product overview



Service

Calibration, DKD

4 - 5

HANDHELD INSTRUMENTS (with sensors and accessories)



Temperature	6 - 15	pH, Redox	31 - 36
Pt100 / Pt1000, Thermocouples	6 - 11	Pressure	37 - 48
Infrared	12 - 14	Oxygen	49 - 52
Hay measuring probes	15	Carbon monoxide	53
Air humidity, Flow rate	16 - 20	Anemometer, Phono, etc.	54 - 55
Material humidity	21 - 25	Accessories / Software	56 - 58
Conductivity	26 - 30		

INDUSTRIAL MEASUREMENT



Display / Controller	59
Display instruments for control panel mounting	60 - 69
Regulator for control panel mounting	62, 63, 66 - 71
Plug-on display Special construction, Power supply, Accessories	72 - 73
Special construction, Power supply, Accessories	74 - 75
Panel-mounted modules (Temperature, Pressure, Current, Voltage)	76



Data logger / EASYBus	77
Data logger	78 - 82
EASYBus overview	83
EASYBus sensor modules	62, 65, 84 - 87
EASYBus regulators	62, 66 - 68, 88 - 89
EASYBus accessories and software	58, 90 - 94



Transmitter / Sensors	95
Transmitters	96 - 111
Temperature, Humidity, Pressure, Conductivity, pH, Redox, O ₂ , CO, CO ₂ , Flow	
Flow meter, Flow switch, Level switch, Rotational speed meter	112 - 119



Temperature probes	
Pt100 / Pt1000, Thermocouples	121 - 135



Alarm- and Protection devices	136
Alarm- and Control devices (Liquid level, Leakage)	137 - 141



Ex-Protection	
Measuring instruments (Pressure)	40 - 45
Displays	60, 72
Transmitters	101, 102
Temperature probes	129

Handheld instrument

Display / Controller

Logger / EASYBus

Transmitter

Temperature probe

Alarm / Protection

for return to national standards		
1. Readjustment	2. Factory Calibration Certificate	3. DKD Calibration Certificate
After a longer period of use, it's recommendable to send in the devices (e.g. humidity) for readjustment. At this, the device will be fully checked up and new adjusted, if required.	DIN EN ISO 9000ff demands a traceable calibration of measuring and test equipment. This calibration certificate is a low-priced alternative to the DKD Calibration Certificate.	The DKD Calibration Certificate always conforms to form, structure and procedures the standards and requirements of the German Calibration Service according DIN EN ISO 17025.



Which certificate will be required ?

Factory Calibration Certificate: could be deemed to be sufficient, if the devices acts as measuring and test equipment within quality management systems according to DIN EN ISO 9000ff or similar, as long as there are not used as a standard. Furthermore there are some measurement categories, without possibility to get a DKD accreditation.

DKD-Calibration Certificate will be recommended for the recalibration of testing equipment which itself is used as a standard for the monitoring of other measuring and test equipment. It's also possible that internal demands of the particular companies makes a DKD Calibration Certificate necessary.

1. Readjustment: (without certificate of calibration) Readjustment of the device

2. Factory calibration certificate:

Calibration certificates are available for all handheld instruments marked with the symbol .

Also possible for measuring transmitters resp. combinations of display instruments and sensors/transmitters.

Temperature:

Certificate of calibration WPT

incl. 1 meas. point

additional meas. point (from -30 to +500°C)

additional meas. point (>500 to 1300°C)

Certificate of calibration WPT2A

with standard values: 0°C / +70°C

Certificate of calibration WPT2B

with standard values: 0°C / +37°C

Certificate of calibration WPT3

with standard values: -20°C / 0°C / +70°C

Pressure:

Certificate of calibration WPD5

5 points ascending, 5 points descending

Certificate of calibration WPD10

10 points ascending, 10 points descending

Humidity:

Certificate of calibration WPF4

incl. standard-meas. values (approx. 20% / 40% / 60 / 80 %RH increasing and decreasing)

Conductivity:

Certificate of calibration WPL3

3 points: ~147 µS/cm, ~1412 µS/cm, ~12,90 mS/cm

Certificate of calibration WPL10

10 points from 0.9 µS/cm to ~192 mS/cm

Ultrapure Water:

Certificate of calibration WPL3-RW

3 points: ~2,50 µS/cm, ~7,00 µS/cm, ~15,00 µS/cm

pH:

Certificate of calibration WPP3

3 points: 4,00 pH, 6,87 pH, 9,18 pH

Certificate of calibration WPP10

10 points from 1.09 pH to 12.75 pH

Atmospheric Oxygen:

Certificate of calibration WPO3

3 points: 0 / 20.9 / 100 % O₂

Note: a replacement of the sensor, before issue the WPO3, is recommended for sensors with an age of one year!

3. DKD calibration certificates (according DIN EN ISO 17025): guiding price - exact costs on request.

Temperature:

DKD-certificate (incl. 1 meas. point)

additional meas. points (from -80 to +500°C)

Pressure:

(for each order a add. handling charge of € 25,-- must paid)

Over pressure -1...100 bar

(incl. 9 points increase and decrease)

Absolute pres. 0...70 bar

(incl. 9 points increase and decrease)

Humidity: (incl. 1 temperature value)

for devices with external sensor

(Testing points: 15 %RH and 70 %RH / at 23 °C)

for devices with fixed attached sensor

(Testing points: 20 %RH, 50 %RH and 80 %RH / at 20 °C)

For the storage of the devices, we recommend the use of a safe-keeping case

Calibration and Testing

Complete Solutions: **Komplett**



GTH175/Pt - WPT2 (immersion probe)
incl. certificate of calibration WPT2A (0°C / 70°C) and case GKK252.

GTH175/Pt - WPT3 (immersion probe)
incl. certificate of calibration WPT3 (-20 / 0 / +70°C) and case GKK252.



GTH175/Pt-E - WPT3 (insertion probe)
incl. certificate of calibration WPT3 (-20 / 0 / +70°C) and case GKK252.

GTH1170 incl. GTF900 - WPT
incl. certificate of calibration WPT (with meas. points: 0 / 100 / 250 / 500°C) and case GKK1100.

GFTH200 - WPF4
incl. certificate of calibration WPF4 (~20% / ~40% / ~60% / ~80%RH increasing and decreasing) and case GKK252.

GMH3330 incl. TFS0100E - WPF4
incl. certificate of calibration WPF4 (~20% / ~40% / ~60% / ~80%RH ascending / descending) and case GKK3500.

GMH3161-07/-12/-13 - WPD5
incl. certificate of calibration WPD5 (5 points ascending / descending) and case GKK3000.

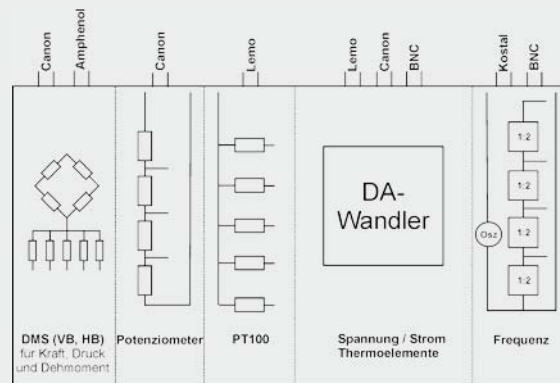

Test Standard

The Test Standard is used for quick testing and checking of measuring devices like strain gauge and thermocouple amplifiers, tachometer generators and others. Rechargeable battery operation and mains operation allow mobile and flexible use. Handling of the device is done by the user via a membrane keyboard, settings are displayed by a 2x16 digit LCD.

Physical quantities like pressure, force, or torque can be entered directly by the user, allowing simultaneous correlation of the measuring device readings. The microprocessor of the test standard converts for example the continuous sensitivity changes of a strain gauge bridge into the resulting force in Newton.

Specifications

General

Supply voltage: 15 V (400 mA), with AC adapter
Environm. temperature: 0..50 °C
Dimensions: 255 x 65 x 190 mm (H x W x D)

Strain gauge, force, torque, pressure

Sensitivity: 0.25, 0.5, 1, 2, 4, 20, 40 mV/V
Accuracy: ± 0.1 % FS for values ≥ 1 mV/V
Bridge type: Full bridge, half bridge 350 Ω
Output: 6-wire technology

Voltage

Ranges: (Fixed selectable ranges)
100 mV, 200 mV, 500 mV,
1 V, 2 V, 5 V, 10 V
(Numerical entry via keyboard):
± 10 V, variabel
Accuracy: ± 0.05 % FS
Temp. drift: (nach Autoabgleich)
0.2 mV/°C (auto adjust)

Current

Ranges: (Fixed selectable ranges)
0, 4, 10, 20, 40 mA
Bereich: (Numerical entry via keyboard)
0..50 mA, variable (Umax 10 V)
Accuracy: ± 0.03 % FS (auto adjust)

Thermocouples J, K

Ranges: -50, 0, +50, +150, +200 °C,
watch CJC
Accuracy: ± 0.2 % FS

Pt100

Temperature: -50, 0, +50, +100, +150, +200 °C
Ranges Resistance: 80,31 / 100 / 119,4 / 138,5 /
157,3 / 175,8 Ω
Accuracy: ± 0.2 % FS
Output: 4-wire, constant current supply

Frequency (Speed)

Ranges: 0,5, 2, 10, 50, 200, 1000 Hz
5, 10, 15*, 20, 62*, 100, 138* kHz
Type: TTL square, PWM 1:1
Accuracy: ± 0.02 % FS, * 0.1 %

Temperature handheld instruments



Application:	Device	GMH 3710	GMH 3750	GMH 2710	GMH 2710-K	GTH 175/Pt	GTH 175/Pt-E	GTH 175/Pt-K	GMH 175	GMH 3210	GMH 3230	GMH 3250	GTH 1150	GMH 1150	GTH 1170	GMH 1170
Reference- / precision measurement		✓	✓													
Quality management		✓	✓	✓	✓	✓	✓	✓	✓	✓	✓	✓			✓	
Difference meas.											✓	✓				
Surface measurement										✓	✓	✓	✓	✓	✓	✓
Core temperature measurement					✓			✓								
High-temperature measurement		✓	✓							✓	✓	✓	✓	✓	✓	✓
Food, HACCP		✓	✓	✓	✓	✓	✓	✓		✓	✓	✓				
Water-proof thermometer				✓	✓											
Air- / gas- / liquids-measurement		✓	✓	✓	✓	✓	✓	✓	✓	✓	✓	✓	✓	✓	✓	✓

Function / Equipment:	Device	GMH 3710	GMH 3750	GMH 2710	GMH 2710-K	GTH 175/Pt	GTH 175/Pt-E	GTH 175/Pt-K	GMH 175	GMH 3210	GMH 3230	GMH 3250	GTH 1150	GMH 1150	GTH 1170	GMH 1170
Specification																
Sensor element		Pt100	Pt100	Pt1000	Pt1000	Pt1000	Pt1000	Pt1000	Pt1000	J, K, N, S, T	J, K, N, S, T	J, K, N, S, T	K	K	K	K
(max.) Meas. range [°C]		-200..+850	-200..+850	-200..+200	-200..+250	-199..+199	-199..+199	-199..+199	-199..+199	-220..+1750	-220..+1750	-220..+1750	-50..+1150	-50..+1150	-65..+1150	-65..+1150
Accuracy (typ.)		≤ 0,03 °C		± 0,1 °C		± 0,1% of m.v.			± 0,1 °C	± 0,03% of m.v. ± 0,05% FS (in example for type K)			≤ 1%		± 0,05% of m.v. ± 0,2% FS.	
Resolution [°C]		0,01 / 0,1	0,01 / 0,1	0,1	0,1	0,1	0,1	0,1	0,1	0,1 / 1	0,1 / 1	0,1 / 1	1	1	1	1
Plug-in probe		✓	✓						✓	✓	✓	✓	✓	✓	✓	✓
Meas. inputs		1	1	1	1	1	1	1	1	1	2	2	1	1	1	1
Display rows		2	2	2	2	1	1	1	1	2	2	2	1	1	1	1
Functions:																
Min/Max, Hold, Auto-Off		✓	✓	✓	✓					✓	✓	✓			✓	✓
Alarm (buzzer)			✓									✓				
Data logger			✓									✓				
Interface		✓	✓							✓	✓	✓				
Analog output		✓	✓							✓						
Catalog page		p. 7	p. 7	p. 8	p. 8	p. 9	p. 9	p. 9	p. 9	p. 10	p. 10	p. 10	p. 11	p. 11	p. 11	p. 11

Pt100 - High-Precision Thermometer

Reference meter for any calibration requirement



- Suitable for all Pt100 4-wire probes with 4-pin miniature DIN-plug
- Highest accuracy and resolution (0,01°C)
- Freely adjustable analog output 0-1V or serial interface
- Offset and slope input
- Min-/max- value memory, hold function

Additional functions of the GMH3750:

- 2 integrated logger functions
- Optical and acoustic min-/max- alarm
- Userdefined sensor curve (50 interpolation points)
- Real-time clock with day, month and year

GMH 3710 access. not incl.

GMH 3750 access. not incl.

Microprocessor precision thermometer for Pt100 4-wire

Application: reference measurings in liquids, soft media, air/gases.

Specifications

Measuring range:

-199,99 ... +199,99°C resp. -200,0 ... + 850,0°C

-199,99 ... +199,99°F resp. -328,0 ... +1562,0 °F

Resolution: 0,01°C resp. 0,1°C
0,01°F resp. 0,1 °F

Linearisation: digital stored characteristic curve
GMH3750 add. supports an userdefined curve.

Auto-range: automatically or manually choose of the measuring range.

Accuracy: (±1 digit) (at nominal temperature = 25°C)
≤ 0,03 °C / 0,06 °F at resolution 0,01 °
≤ 0,1 °C / 0,2 °F at resolution 0,1 °

Temperature drift: ≤ 0,002 °C / K

Probe: Pt100, 4-wire, in acc. to DIN EN 60751
probe connection via 4-pin miniature DIN-plug

Nominal temperature: 25°C

Working temperature: -25 to +50°C

Relative humidity: 0 to +95%RH (non-condensing)

Storage temperature: -25 to +70°C

Display: two 4½ digit LCDs (12,4mm or 7mm high), as well as additional arrows.

Pushbuttons: 6 membrane keys

Output: 3-pin jack connector Ø3.5 mm, choice between seriell interface or analog output

- **serial interface:** direct connection to RS232 or USB interface of a PC via electrically isolated interface adapter GRS3100 or GRS3105 resp. USB3100 (p.r.t. accessories).

- **analog output:** 0...1V, freely adjustable (resolution 13bit, accuracy 0.05% at nom. temp.)

Power supply: 9V-battery, type IEC 6F22 (included) as well as additional d.c. connector for external 10.5-12V direct voltage supply. (suitable power supply: GNG10/3000)

Low battery warning: 'bAt'

Power consumption: approx. 1 mA

Dimensions: 142 x 71 x 26 mm (H x W x D)
Impact-resistant ABS plastic housing, membrane keyboard, transparent panel. Front side IP65, integrated pop-up clip.

Weight: approx. 155 g

Functional range:

Min./Max. value memory: Memorizing of max. and min. values.

Hold function: By pressing a button the current values will be "frozen".

Auto-Off-Function: 1...120 min (can also be deactivated).

Offset and slope input: offset- and scale correction can be entered digitally.

Additional functions of the GMH3750:

Min-/Max-alarm: the measuring value is constantly monitored if they remain within the min./max. limits set.

- **Alarm:** 3 different alarm settings
off: alarm function not activated
on: visual alarm via display, integrated buzzer and interface

no Sound: alarm via display and interface

- **Regulating function:** with the help of the switching module GAM3000 (optionally) electric equipment can be switched on/off or alarm memorised (p.r.t. page 41)

Logger functions:

- **manually:** 99 data sets (data recall via keyboard or interface)

- **cycle:** 16.384 data sets (data recall via interface)

- **adjustable cycle time:** 1 sec. ... 1 h

Logger start and stop via the keyboard or interface. Comfortable read-out and display software (GSOFT3050) available as additional equipment.

Real-time clock: clock with day, month and year

Accessories

plug-in probes Pt100 p.r.t. page 121

GLF 401 Mini Air probe (p.r.t. p. 121)

 for fast and accurate measurements in ambient air

GKK 1100 case (340 x 275 x 83 mm) with foam lining for universal use

USB 3100 N interface converter

GSOFT 3050 software (p.r.t. p. 56)

ST-R1 device protection bag

GNG 10 / 3000 power supply
miscellaneous accessories p.r.t. pages 56 - 58

Calibrated Systems

General

The overall error of a measuring consists of the sum of the instrument error and the probe error. To minimise the overall error, we offer calibrated and optimized systems below.

Due to their excellent system accuracy they are especially suitable for quality assurance according to ISO9000ff, as reference instruments in manufacturing processes, laboratory, service and maintenance, etc.

The system optimization is done via a special characteristic curve which is determined for each temperature probe separately and stored in the instrument (GMH3750) or. with probe adjusting via offset and slope input (GMH3710).



Scope of supply:

Measuring device GMH 3750 or GMH 3710, temperature probe GTF 401 1/3 DIN, plastic case GKK 3500 and certificate of calibration with 3 calibration points.

GMH 3750 / SET1

incl. certificate of calibration

optimized measuring range: -20 .. +70°C

Temperature probe: GTF 401 1/3 DIN, Pt100, 4-wire
(for tech. data please refer to p. 121)

System accuracy: better than 0,07°C (at opt. range)

Calibration points: -20°C / 0°C / 70°C

GMH 3750 / SET2

incl. certificate of calibration

optimized measuring range: 0 .. +250°C

Temperature probe: GTF 401 1/3 DIN, Pt100, 4-wire
(for tech. data please refer to p. 121)

System accuracy: better than 0,3°C (at opt. range)

Calibration points: 0°C / 100°C / 250°C

GMH 3710 / SET1

incl. certificate of calibration

optimized measuring range: -20 .. +70°C

Temperature probe: GTF 401 1/3 DIN, Pt100, 4-wire
(for tech. data please refer to p. 121)

System accuracy: better than 0,1°C (at opt. range)

Calibration points: -20°C / 0°C / 70°C

GMH 3710 / DKD1

incl. DKD calibration certificate
DIN 17025

optimized measuring range: -20 .. +70°C

Temperature probe: GTF 401 1/3 DIN, Pt100, 4-wire
(for tech. data please refer to p. 121)

System accuracy: better than 0,1°C (at opt. range)

Calibration points: -20°C / 0°C / 70°C

Calibration accessories

GMHKonfig free

(visit out homepage: Download --> Software)

Software description:

Comfortable software to edit the user defined sensor curve of the GMH3750. (e.g. for calibration laboratories etc.)

Note: please note that for the interface communication with the device a interface converter (GRS3100, GRS3105 or USB3100) is necessary (p.r.t. page 57)

Waterproof HACCP-Thermometer with Pt1000-probe



HACCP



Features

- Waterproof (device and probe)
- Easy handling
- Min-/Max. value memory
- High accuracy ($\pm 0.1\text{ }^{\circ}\text{C}$ ± 1 digit)
- Automatic freezing of constant measuring value (Auto-Hold)
- Battery life time > 6000 hours

GMH 2710 Temperature measuring device incl. universal probe

GMH 2710-K Temperature measuring device incl. teflon probe

Field of application

High-precision measurements:

- Laboratory
- Quality management
- Production process control

Areas:

- Foods (HACCP)
- Medicine / pharmaceuticals
- Chemistry
- Fishkeeping, aquafarming, aquaculture
- Etc.

General functions

- Auto-Power-Off
- Min-/Max. value memory
- Can be calibrated (zero point & slope)
- Automatic freezing of constant measuring value (Auto-Hold)
- Low battery display "BAT"

Accessories

K 50 BL
silicone protection cover (blue)

K 50 RE
silicone protection cover (red)



Specification

Measuring ranges:

GMH 2710 -200.0 ... +200.0 $^{\circ}\text{C}$

GMH 2710-K -200.0 ... +250.0 $^{\circ}\text{C}$

Resolution: 0.1 $^{\circ}\text{C}$

Accuracy:

at -20.0 ... 100.0 $^{\circ}\text{C}$ $\pm 0.1\text{ }^{\circ}\text{C} \pm 1$ digit

at -70.0 ... 200.0 $^{\circ}\text{C}$ $\pm 0.1\%$ of meas. value ± 2 digit

Probe is calibrated to the device

Probe:

Pt1000, 2-wire, potential-free, waterproof and steam-tight, permanently connected to device

\varnothing 3 mm / length: 100 mm,

GMH 2710 Plastic handle, 135 mm long, max. 70 $^{\circ}\text{C}$
1 m PVC-cable, max. 100 $^{\circ}\text{C}$

GMH 2710-K Teflon handle and 1m Teflon cable, both handle and cable are resistant to permanent high temperatures up to 250 $^{\circ}\text{C}$, stainless steel bend protection

Reaction time T_{90} :

approx. 10 s

Display:

two 4-digit LCD (12.4 mm and 7 mm)

Nominal temperature:

+25 $^{\circ}\text{C}$

Working temperature:

-25 to +50 $^{\circ}\text{C}$

Storage temperature:

-30 to +70 $^{\circ}\text{C}$

Power supply:

2 x AAA-batteries

Battery life time:

> 6000 hours

Protection class:

IP65 / IP67

Dimensions:

154 x 81 x 31 mm (H x W x D)

215 g (incl. battery and probe)

Impact resistant ABS housing

High accuracy and precision for a minimum of price!



PRECISION POCKET THERMOMETER

GTH 175/Pt

Battery operation, complete with probe

Application: high-precision measurements in liquids, core measurements (using insertion probe), for air/gases or as reference device for calibrating other, more expensive systems!

Specification

- Measuring range:** -199,9 ... +199,9 °C
- Resolution:** 0,1 °C
- Accuracy:** 0,1 % of m.v. ±2 digit (within range of: -70.0 ... +199.9 °C), probe is calibrated to the device, i.e. the error in the range of 0 to 100 °C will be approx. 0,1 °C ± 1 digit.
- Probe:** Pt1000, 2-wire, electrically isolated and mounted in st. steel tube (1.4571) 3 mm Ø and approx. 100 mm long, plastic handle approx. 135 mm long, anti-buckling glanding and 1 m of highly flexible silicone cable - permanently connected to the device.
- Display:** 3½ digit, approx. 13 mm high
- Nominal temperature:** +25 °C
- Working temperature:** -30 to +45 °C
- Storage temperature:** -30 to +70 °C
- Power supply:** 9V battery type IEC 6F22 (included)
- Battery service life:** approx. 200 operating hours
- Low battery warning:** „BAT“
- Dimensions:** device: approx. 106 x 67 x 30 mm (H x W x D). impact resistant ABS plastic housing
- Weight:** approx. 190 g (incl. battery and probe)

GTH 175/Pt-E instrument with insertion probe

Specification: refer to GTH 175/Pt
probe (st. steel tube, Ø 3mm x 100mm) like above, however with insertion probe for all soft media

GTH 175/Pt-K core temperature meas. instrument

Specification: refer to GTH 175/Pt
probe (st. steel tube, Ø 3mm x 100mm) like above, however with teflon handle and 1m teflon cable. Both handle and cable are resistant to **air temperature of up to 250 °C** and can remain in the oven.

Option (upcharges)

- Probe water-proof
Probe like GTH 175/Pt but with PVC-cable (max. 100 °C) and sealed handle (max. 70 °C)

Special design types: (on request)

e.g. probe cable in another length, sensor tube in another length.

Accessories

- GB 9 V** spare battery
- GKK 1100** case (340 x 275 x 83 mm) with foam lining
- Komplett-offering** device incl. certificate of calibration and case

p.r.t. page 5

for additional accessories p.r.t. page 56 - 58

High accuracy and precision, plug-in probe, battery and permanent mains operation possible



PRECISION THERMOMETER

GMH 175

Battery/mains operation, for plug-in probes, Pt1000 2-wire

Application: high-precision measurements in liquids, soft media, air/gases

Specification

- Measuring range:** -199,9 ... +199,9 °C
- Resolution:** 0,1 °C
- Accuracy:** (at nominal temperature = 25°C)
device: 0,1 °C ± 1 digit (within range of: -70.0 ... +199.9 °C)
- Probe:** Pt1000 probe, 2-wire, probe connection via 3.5 mm Ø jack connector.
Probes not included - please order separately!
For suitable, volt-free sensors see below or refer to page 122.
- Display:** 3½ digit, approx. 13 mm high
- Working temperature:** -30 to +45 °C (**low temperature** - for use in cold storage rooms!)
- Storage temperature:** -30 to +70 °C
- Power supply:** 9V-Battery type IEC 6F22 (included) as well as additional d.c. connector for external 10.5-12V direct voltage supply. (suitable power supply: GNG10/3000)
- Battery service life:** approx. 200 operating hours
- Low battery warning:** „BAT“
- Dimensions:** approx. 142 x 71 x 26 mm (H x W x D). impact resistant ABS plastic case, front side IP65, integrated pop-up clip for table top or suspended use.
- Weight:** approx. 160 g (incl. battery)

Accessories

- Suitable plug-in temperature probes:
(Probes interchangeable without recalibration.)
- GTF 175** immersion probe for liquids and aggressive gases
- GES 175** insertion probe for soft media
- GOF 175** surface probe for any solid surface
- GLF 175** air/gas probe for clean media
Detailed description and more probes please refer to page 122
- ST-R1** device protection bag with cut-out for probe connection, suitable for GMH175, ...
- GB 9 V** spare battery

for additional accessories p.r.t. page 56 - 58

Digital precision quick-response thermometer for thermocouples



General functions:

- 5 different thermocouples can be used! (types J, K, N, S, T)
- Correction of meas. values for surface meas. can be switched on / off
- Serial interface, device can be connected to bus system

Additional functions of GMH 3230 and GMH 3250:

- 2 plug-in probes can be connected and read simultaneously
- Temperature differences

Additional functions of the GMH 3250:

- 2 integrated logger functions
- Optical and acoustic min-/max- alarm
- Real-time clock with day, month and year

Additional functions of the GMH 3210:

- Analog output 0 - 1 V

GMH 3210 accessories not incl. for connection of 1 plug-in probes

GMH 3230 accessories not incl. for simultaneous connection of 2 plug-in probes

GMH 3250 accessories not incl. for simultaneous connection of 2 plug-in probes

suitable probes
p.r.t. p. 123-125

Specification:	GMH 3210	GMH 3230	GMH 3250
Thermocouples:	J, K, N, S, T	J, K, N, S, T	J, K, N, S, T
Resolution:	0,1°C or. 1°C	0,1°C or. 1°C	0,1°C or. 1°C
Measuring range:	-220°C ... +1750°C (depending on thermocouples)		
Measuring ranges: (extract)			
Type K: (MR1)	-65,0 ... +300,0°C	-199,9 ... +999,9°C	
(MR2)	-220 ... +1372°C	-220 ... +1372°C	
	<i>further measuring ranges online at www.greisinger.de</i>		
Accuracy: (extract)			
Type K: (for MR1)	±0,03% of m.v. ±0,05%f.s.	±0,03% of m.v. ±0,05%f.s. (≥-60°C)	±0,2% of m.v. ±0,05%f.s. (<-60°C)
(for MR2)	±0,08% of m.v. ±0,1%f.s.	±0,08% of m.v. ±0,1%f.s. (≥-100°C)	±1°C ±0,1%f.s (<-100°C)
Working temperature:	-25 to +50°C	-25 to +50°C	
Probe connections:	1	2	2
Display:	2 four digit LCDs (12.4mm and 7mm high)		
Output:	3-pin jack connector Ø3.5mm		
serial interface:	direct connection to RS232 or USB interface of a PC via electrically isolated interface adapter GRS3100 or GRS3105 resp. USB3100 (p.r.t. accessories).		
analog output:	x	-	-
Power supply:	9V-battery, type IEC 6F22 (included) as well as additional d.c. connector for external 10.5-12V direct voltage supply. (suitable power supply: GNG10/3000)		
Power consumption:	approx. 0.3 mA	approx. 1,7 mA	approx. 1,6 mA
Housing dimensions:	142 x 71 x 26 mm (L x W x D), Impact-resistant ABS plastic housing. Front side IP65, integrated pop-up clip for table top or suspended use. Weight: approx. 155 g		
Functions:			
Min./Max. value memory	x	x	x
Hold function	x	x	x
Auto-Off-function	x	x	x
Low battery warning	x	x	x
Special applications:			
Compensation value for surface measurements	x	x	x
Zero-point offset entry	x	x	x
Difference measurements	-	x	x
Tare/diff-function	-	x	x
Min-/Max-alarm	-	-	x
Logger functions	-	-	x
Real-time clock	-	-	x

Functional Description
Compensation value for surface measurements: A compensation value (to compensate for the loss when transferring heat from the meas. object to the probe) can be set and switched on/off for surface measurements if required.
Zero-point offset entry: By entering the offset temperature the parameter can be moved parallel to the calibration graph.
Difference measurements: with a resolution of 0,1° or 1°. Temperature difference probe 1 - probe 2 can be displayed if 2 probes are connected.
Tare/diff-function: Press button to set the difference display 'probe 1 - probe 2' to zero.
Analog output: 0 ... 1V, freely adjustable (resolution 13bit, accuracy 0.05% at nom. temp.)
Min-/Max-alarm: The meas. values of probe 1 or 2, probes 1 and 2 or the temp. difference are constantly monitored reg. the min. and max. values set.
- Alarm: 3 different alarm settings off: alarm function not activated on: visual alarm via display, integrated buzzer and interface no Sound: alarm via display and interface
- Controlling function: with the help of the switching module GAM3000 (optionally) electric equipment can be switched on/off or alarm memorised (see accessories)
Logger functions:
- manually: 99 data sets (data recall via keyboard or interface)
- cycle: 9.999 data sets (data recall via interface)
- adjustable cycle time: 1sec. ... 1h Logger start and stop via the keyboard or interface. Comfortable read-out and display software (GSOFT3050) available as additional equipment.
Real-time clock: clock with day, month and year.

Handheld instrument

Display / Controller

Logger / EASYBus

Transmitter

Temperature probe

Alarm / Protection

Maximum speed, universal application, low price



QUICK RESPONSE THERMOMETER

GTH 1150

Battery operation, for plug-in probes

GMH 1150

Battery/mains operation, for plug-in probes

Application: quick response measurements on surfaces, in liquids, soft media, air/gases, at the smallest objects etc. For all applications where a resolution of 1 °C is sufficient.

Specification

Measuring range:	-50 ... +1150 °C
Resolution:	1 °C
Accuracy:	≤ 1 % ± 1 Digit (from -20 to +550 and 920 to 1150 °C) (at nominal temperature) ≤ 1.5 % ± 1 Digit (from 550 to 920 °C) from -20 to -50 °C according to attached correction table
Probe connection:	standard flat-pin plug (free of thermo-voltage) suitable for all NiCr-Ni (type K) - probes. <i>Probe is not included in scope of supply - optimum probe to be ordered separately depending on desired application! Refer to pages 123 - 127.</i>
Display:	3½ digit, approx. 13 mm high
Nominal temperature:	25 °C
Working temperature:	0 to 45 °C
Storage temperature:	-20 to +70 °C
Power supply:	9V battery type IEC 6F22 (included). Additional at GMH 1150: d.c. connector for external 10.5-12V direct voltage supply. (suitable power supply: GNG10/3000)
Power consumption:	approx. 0.4 mA
Battery service life:	approx. 700 operating hours
Low battery warning:	„BAT“
Dimensions:	GTH ... approx. 106 x 67 x 30 mm (H x W x D). impact resistant ABS plastic housing. GMH ... approx. 142 x 71 x 26 mm (H x W x D). impact resistant ABS plastic housing, front side IP65, integrated pop-up clip for table top or suspended use.
Weight:	approx. 150 g (GTH 1150), approx. 160 g (GMH 1150)

Accessories

- GTF 300** wire probe (for measuring ranges -65 ... 300 °C)
- additional NiCr-Ni probes** *p.r.t. page 123 - 127*
- GB 9 V** spare battery
- GKK 252** case (235 x 185 x 48 mm) with foam lining
- GKK 3000** case (275 x 229 x 83 mm) with punched lining
suitable for all devices of the GMH3xxx-series, GMH 1150
- ST-KN** device protection bag, suitable for GTH 1150
- ST-N1** device protection bag, suitable for GMH 1150
- GNG 10/3000** power supply

for additional accessories p.r.t. page 56 - 58

High precision, low power consumption, min-/max-value memory, hold function, auto-off function, down to -25°C ambient temperature, °C and °F, offset/scale



PRECISION QUICK RESPONSE THERMOMETER

GTH 1170

Battery operation, for plug-in probes, °C / °F (0,1° or 1°), min./max. value memory, hold, automatic-off, offset/scale

GMH 1170

Battery operation, for plug-in probes, °C / °F (0,1° or 1°), min./max. value memory, hold, automatic-off, offset/scale

Application: quick response measurements on surfaces, in liquids, air/gases etc.

Specification

Measuring ranges:	-65,0 ... +199,9 °C or -65 ... +1150 °C (-85,0 ... +199,9 °F or -85 ... +1999 °F)
Resolution:	0,1 °C or 1 °C (0,1 °F or 1 °F)
Accuracy:	-65,0...+199,9 °C: ±0.05 % of m.v. ±0.2 % FS ± 1 digit (at nom. temperature) -65 ... 1150 °C: ±0.1 % of m.v. ±0.2 % FS
Temperature drift:	0,01 %/K
Point of comparison:	±0,3 °C
Probe connection:	standard flat-pin plug (free of thermo-voltage) suitable for all NiCr-Ni (type K) - probes. <i>(for suitable probes please refer to pages 123 - 127)</i>
Offset and Scale:	digital offset and scale adjustment for optimum precision.
Display:	3½ digit, approx. 13 mm high
Working temperature:	-25 to +50 °C
Storage temperature:	-25 to +70 °C
Power supply:	9V battery type IEC 6F22 (included)
Measuring interval:	approx. 3 meas. / sec.
Power consumption:	approx. 0.15 mA
Battery service life:	approx. 2000 operating hours
Low battery warning:	„BAT“
Auto-off-function:	selectable from 1 to 120 min. or deactivated.
Min./Max. value memory:	memorizing of max. and min. values.
Hold function:	By pressing a button the current values will be memorized.
Dimensions:	GTH ... approx. 106 x 67 x 30 mm (H x W x D). impact resistant ABS plastic housing. GMH ... approx. 142 x 71 x 26 mm (H x W x D). impact resistant ABS plastic housing, front side IP65, integrated pop-up clip for table top or suspended use. approx. 135 g (GTH 1170), approx. 150 g (GMH 1150)
Weight:	

Accessories

- NiCr-Ni probes** *p.r.t. page 123 - 127*
- GB 9 V** spare battery
- GKK 252** case (235 x 185 x 48 mm) with foam lining
- GKK 3000** case (275 x 229 x 83 mm) with punched lining
suitable for all devices of the GMH3xxx-series, GMH 1170
- ST-KN** device protection bag, suitable for GTH 1170
- ST-N1** device protection bag, suitable for GMH 1170
- Komplett-offering** *p.r.t. page 5*
device incl. certificate of calibration and case

for additional accessories p.r.t. page 56 - 58

Temperature infrared handheld instruments



Application:	Device	GMTL 1826 - MT4	GIM 530 MS	GIM 1840 - ST25 XB	GIM 3590
Precision measurement			✓		✓
Fast scanning of surfaces		✓	✓	✓	✓
Food		✓	✓	✓	✓
Data storage					✓
Quality management		✓	✓	✓	✓
Universal use (due to adjustable emission rate)			✓		✓

Function / Equipment:	Device	GMTL 1826 - MT4	GIM 530 MS	GIM 1840 - ST25 XB	GIM 3590
Specification					
Meas. range [°C]		-18..+400	-32..+530	-32..+535	-35..+900
Resolution [°C]		0,2	0,1	0,2	0,1
Response time T ₉₅		500 ms	300 ms	500 ms	150 ms
Laser		single	single	cross	cross
additional probe connection					type K
Optical resolution (Distance / Spot size)		8:1	20:1	16:1	75:1
Emissionsgrad		fest auf 0,95	0,100 .. 1,000	fest auf 0,95	0,100 .. 1,100
Functions					
General functions			Min/Max, Hold, Offset	Max, Hold	Min/Max, DIF, Hold, AVG
Alarm			optical, acoustical	--	optical, acoustical
Data storage and visualisation					100 meas. protocols, software for visualisation
Interface					✓
Catalog page		p. 13	p. 13	p. 14	p. 14

The infrared digital hand-held thermometer at low cost price



GMTL 1826 - MT4

(with laser visor)

The GMTL1826-MT4 is compact, light-weight and easy to use: Just aim, trigger and read the temperature from the backlight display - that's all. Your search for a quick and safe way to measure temperature has found a solution: The GMTL 1826 infrared thermometer.

Examples for application:

- **Electric and electronics** - detection of hot spots
- **Ventilation/heating and air conditioning** - inspection of heat exchangers ...
- **Food** - inspection of temperature when keeping warm or cooling food.

Specification:

Range: -18 ... +400°C (0 ... +752°F)
Resolution: 0.2°C or 0.5°F
Temperature display: °C or °F selectable
Accuracy (at ambient temperature = 23°C ±5°C):
 ±2% of m.v. resp. ±2°C (highest value shall be valid)
 (-18 ... -1°C = ±3°C)
Repeat accuracy: ±2% of m.v. resp. ±2°C
Measuring zone dia: 8 : 1
Response time (t₉₅): 0.5 seconds
Emission rate: set to 0,95
Laser pointing appliance: single ray
Working temperature: 0 ... 50 °C
Storage temperature: -20 ... 65 °C
Power supply: 9V battery type IEC 6F22 (included)
Battery service life: approx. 12 hours
Dimensions: 152 x 101 x 38 mm
Weight: approx. 227 g

Accessories:

GKK 252 small case (235 x 185 x 48 mm) with foam lining
GKK 3100 case (275 x 229 x 83 mm) with foam lining
GB 9 V spare battery

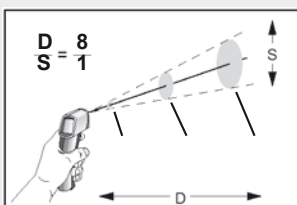

Intelligent multi purpose infrared thermometer with precision glass optic, setting a standards



- adjustable emission rate from 0.100 to 1.000 (for numerous materials important)
- Adjustable visible and audible alarm
- Optical resolution 20:1
- Constant measuring area in between the distance of 13 to 140 mm
- Targeting laser for exact aiming of the object to be measured
- Fast scanning of hot and cold spots within 0.3 seconds

GIM 530 MS

Calibration certificate (testpoints at 23°C, 110°C a. 510°C)

User-friendly industrial design combined to state of the art technology are setting a new standard in professional and all day non-contact temperature measuring.

The large temperature range of -32 to 530°C, the targeting laser and the optical resolution of 20:1 allow very precise measuring of surfaces in a variety of applications. Simply aim at the target with the laser, push the trigger and the value is displayed within 0.3 seconds plus several other informations.

Examples for application:

- **Electrical and mechanical service and maintenance**
- **Heating, ventilation, air-conditioning** - finding thermal bridges etc.
- **Motor vehicle diagnosis, electricity, home improvement**
- **Checking food temperature during keeping warm or storing**

Specification:

Measuring range: -32 ... + 530°C (-20 ... +980°F)
Resolution: 0.1°C (0.1°F)
Temperature display: °C or °F selectable
System accuracy: (at ambient temperature = 23°C ±5°C)
 ±1% or ±1°C from 0°C to 530°C (highest value shall be valid)
 ±1°C ± 0.07°C/°C from 0°C to -32°C
Repeat accuracy: ±0.5% or ±0.7°C from 0°C to 530°C (highest value shall be valid)
 ±0.7°C ±0.05°C/°C from 0°C to -32°C

Optical Resolution (D:S): 20 : 1
Response time (t₉₅): 0.3 seconds
Spectral range: 8 - 14 μm
Emission rate: 0.100 to 1.000, free selectable
Laser: < 1mW laser class IIa
Configuration: min/max/scan/hold/offset/°C/°F
Display illumination: yes
Alarm function: optical and acoustic HIGH-/LOW- alarm
Working temperature: 0 ... 50 °C
Storage temperature: -20 ... 60 °C (without battery)
Power supply: 9V alkaline battery
Battery service life: approx. 20 hours for use with laser and illumination
Weight / Dimensions: approx. 150 g; 190 x 38 x 45 mm (H x W x D)
Scope of supply: Device with battery, operating manual, device bag made of nylon

Accessories:

GKK 252 small case (235 x 185 x 48 mm) with foam lining

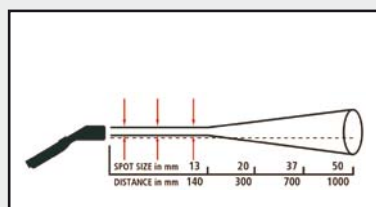

Display

- current temperature value
- MIN-/MAX-value: current and last
- HIGH-/LOW-alarm
- HOLD-function
- emission rate
- symbol for display illumination and laser

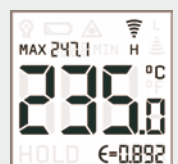

Low price infrared technology for non-contact and quick response surface temperature measurements.
All devices with laser pointing appliance!



GIM 1840 - ST25 XB

Non-contact infrared digital thermometer

Examples for application:

- **PC board test:** super-heated components
- **Ventilation/heating/air conditioning/ civil engineering:** detection of bad insulation, leaking tubes, energy consumption, general service measurements etc.
- **Electric systems, machines, devices:** detection of hot spots at electric connections, heating up of motors, bearings, pumps, compressors etc.
- **Food processing and testing:** temperature of food, storage rooms, processes etc.
- **Medical technology, biological and chemical analyses:** quick-response non-contact temperature measurements, trouble-free operation even when handling dangerous, aggressive media
- **Industry, mechanical engineering, craft and trade:** surface measurements at rotary parts such as rollers, drums, shafts, printing machinery, plastic welding, asphalt, concrete etc.

Specification

Measuring range:	-32 ... +535 °C
Resolution:	0.2°C
Temperature display:	°C or °F selectable
Accuracy: (at 23°C ±5°C)	±1% of measured value or ±1°C (at > 23°C); ±2°C (-18...23°C); ±2.5°C (-26...-18°C); ±3°C (-32...-26°C)
Repeat accuracy:	≤ ±0.5% of measured value or ±1°C
Response time (t95):	0.5 seconds
Rate of emission:	permanently set to 0.95
Laser pointing appliance:	cross over double ray
Meas. functions:	MAX / HOLD / °C / °F
Power supply:	9V-battery type IEC 6F22 (included)
Display illumination:	press key to switch on/off
Working temperature:	0 ... 50 °C
Dimensions:	approx. 160 x 55 x 205 mm
Weight:	approx. 360 g
Storage:	cpl. device with carrying bag and hand loop

Option:

- Certificate of calibration (25 / 100 / 200 °C)

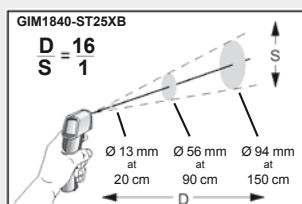

The new LaserSight - series Temperatures in the cross-hair



GIM 3590

Non-contact infrared digital thermometer incl. software

The measured point will be marked exactly with the precision of a laser cross-hair. The integrated sharp point optics allows measurements of even smallest measuring objects down to 1mm. Its position sensor turns the display always to the most comfortable orientation.

- **Measuring range -35 to 900°C**
- **switchable focus point optics**
- **laser cross-hair shows real measuring point size**
- **Optical resolution 75:1**
- **Flip-display**
- **additional thermocouple input**
- **USB interface and graphical software**

Specification

Measuring range:	-35.0 ... +900.0°C (IR and thermocouple type K) thermocouple type K
TC input:	
Resolution:	0.1°C
Accuracy IR:	±0.75°C or ± 0.75% of m.v.*)
Accuracy type K:	±0.75K or ± 1% of m.v. (at 23°C ± 5°C)
Response time (t 95):	150ms
Optical resolution:	75:1 16mm @ 1200mm
at focus point optic:	1mm @ 62mm
Rate of emission:	0.100 to 1.100, selectable
Meas. functions:	MAX / MIN / HOLD / DIF / AVG / °C / °F
Alarm functions:	acoustic / visual high-low-alarm
Display:	LC Flipwith position sensor / bar graph
Backlight:	green or alarm colours (red / blue)
Spectral range:	8 - 14 µm
Working temperature:	0 ... 50°C
Relative humidity:	10 ... 95%, non condensing
Data logger:	100 measurements protocols
Interface:	USB
Software:	oscilloscope software, 20 readings/ s
Voltage supply:	2 x AA alkaline battery o. USB
Weight:	420 g
Scope of supply:	Device incl. USB cable & software, bag, insertion probe type K, batteries, carrying loop, calibration protocol, transport case

Options:

- Certificate of calibration
- Tripod

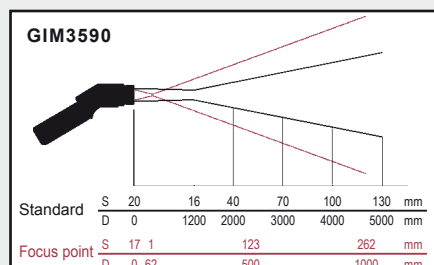

Multi-point hay temperature meas. probe of stainless steel

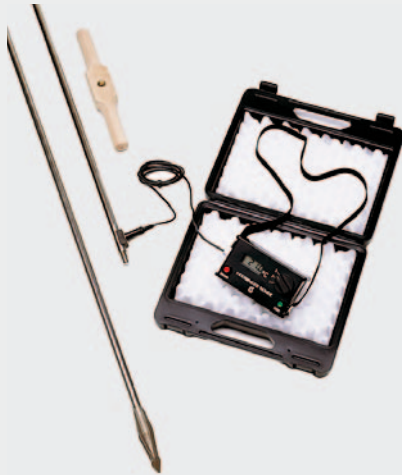

Typ electronic 0150

Fire prevention at self heating of feed by permanent observation of the temperature trend in stored harvests like straw, hay, crop etc.

As well the instrument is suitable to control other kinds of storage.

- rugged stainless steel design
- 3 measuring points alongside probe
- glow and fire zone detection

Specification:

Measuring range: -20°C to +150°C

Resolution: 0,1°C

Accuracy: ±2°C (at nominal temperature)

Probe connection: approx. 2m of PVC connecting cable with five pole connector

Measuring rod: V4A stainless steel probe, length 3.46m, approx. 18mm diameter, 3 measuring points at 20cm, 190cm and 280cm (distance from spike)

OPTION: overall length of 5m

Cutting spike: unscrewable 4-blade spike

Display: 3½-digit, 13mm high LCD-display, display illumination by keypress

Nominal temperature: 25 °C

Working temperature: 0 to 50 °C

Relative humidity: 0 ... 95 %RH (non condensing)

Storage temperature: -10 to 60 °C

Power supply: separate supply for measuring electronics and illumination
measuring electronics: 9 V battery, type IEC 6F22 (1 pcs.)
illumination: mignon / LR 06 / AA 1,5V (2 pcs.)

Battery life: meas. electronics approx. 200 hours of operation
illumination: approx. 50 - 100 hours of operation (depending on battery type)

Dimensions, weight (device): 170 x 90 x 60mm, 450g

Scope of supply: device, two part hay temperature probe (3.46m), wood handle, measuring spike, plastic case, batteries, manual

Options:

Extension rod length 1,5m (max. length 5m)

Spare elements

Measuring spike 4 blade, stainless steel

Instrument incl. connection cable 2m

Packaging hose

Case with foam lining

Upper rod-part

Lower rod-part

Wood handle

Low cost hay temperature measuring probe

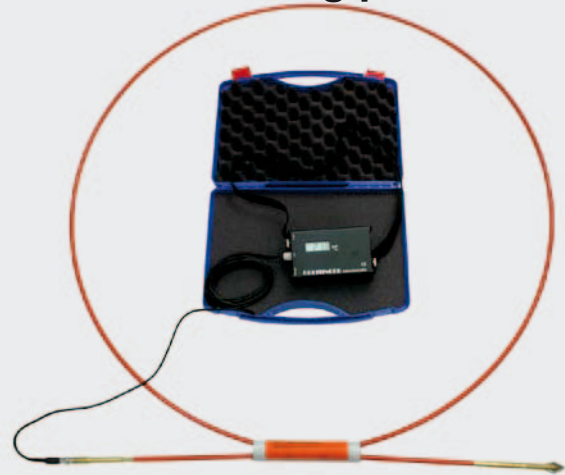

Typ electronic 0120

We offer a economic measure to avoid damage caused by the self-heating due biological processes in stored hay, straw, etc, which may heat up the stored goods up to self ignition.

- fibre glass measuring rod
- one measuring point at the tip
- economical

Specification:

Measuring range: -20.0 ... +120.0 °C

Resolution: 0.1 °C

Accuracy: ± 2 °C (at nominal temperature)

Probe connection: approx. 3m long connection cable with cinch plug and connection adaptor GAD-1 Cinch

Measuring rod: fibre glass probe, approx. 4 m long, approx. 10 mm Ø, 1 measuring point in the probe tip

Cutter tip: double-edged screw-type tip with integrated temperature sensor

Display: 3½-digit, 13mm high LCD-display, display illumination by keypress

Nominal temperature: 25 °C

Working temperature: 0 to 50 °C

Relative humidity: 0 ... 95 %RH (non condensing)

Storage temperature: -10 to 60 °C

Power supply: separate supply for measuring electronics and illumination
measuring electronics: 9 V battery, type IEC 6F22 (1 pcs.)
illumination: mignon / LR 06 / AA 1,5V (2 pcs.)

Battery life: meas. electronics approx. 200 hours of operation
illumination: approx. 50 - 100 hours of operation (depending on battery type)

Dimensions, weight (device): approx. 160 x 90 x 45 mm, approx. 480g

Scope of supply: device, hay temperature probe 4m, measuring spike, plastic case, batteries, manual

Spare elements:

Fibre glass probe, 4m

Cutter tip with integrated temperature sensor

Measuring device incl. connection cable

GKK 3600 case with foam lining

GAD 1 CINCH connection adapter for cable to measuring rod

Humidity / flow rate handheld instrument



Application:	Device	GMH 3330	GMH 3350	GFTH 95	GFTH 200	GFTB 100
Air conditioning		✓	✓	✓	✓	✓
Ambient air monitoring		✓	✓	✓	✓	✓
Meteorology						✓
Living climate						✓
Flow measurement		✓	✓			
Air pressure meas.						✓
Calculation of						
Dew point Td		✓	✓		✓	✓
Wet bulb temperatur Twb					✓	✓
Moisture content x						✓
Absolute humidity d						✓
Dew point distance		✓	✓			
Enthalpy		✓	✓			

Function / Equipment:	Device	GMH 3330	GMH 3350	GFTH 95	GFTH 200	GFTB 100
Specification						
Meas. range						
Humidity		0..100 % r.F.		10..95 % r.F.	0..100 % r.F.	0..100 % r.F.
Humidity (rec. range)		11..90 % r.F.		30..80 % r.F.	11..90 % r.F.	11..90 % r.F.
Temperature		-40..+120 °C / add. external probe		-20..70 °C	-25..+70 °C	-25..+70 °C
Flow		0,05..5,00 bzw. 0,55..20,00 m/s		-	-	-
Pressure		-		-	-	10..1100 mbar
Accuracy						
Humidity (rec. range)		± 0,1 %		± 3 %	± 2,5 %	± 2,5 %
Temperature		± 0,2 % (Pt1000) / ± 0,5 % of m.v. ± 0,5 °C (NiCr-Ni)		± 0,5 % of m.v. ± 0,1 °C	± 0,5 % of m.v. ± 0,1 °C	± 0,5 % of m.v. ± 0,1 °C
Flow		± 0,1 %		-	-	-
Pressure		-		-	-	± 1,5 mbar
Resolution		0,1 % r.F. / 0,1 °C / 0,01 m/s		0,1 % r.F. / 0,1 °C	0,1 % r.F. / 0,1 °C	0,1 % r.F. / 0,1 °C / 0,1 mbar
Plug-in probe		✓	✓		✓	
Functions						
General functions		Min/Max, Hold, Auto-Off	Min/Max, Hold, Auto-Off		Min/Max, Hold	Min/Max, Hold, Auto-Off
Interface		✓	✓			optionally
Alarm			✓			
Data logger			✓			
Catalog page		p. 17	p. 17	p. 19	p. 19	p. 20

humidity, temperature and flow rate measuring device



Komplett

WK

- Double display of humidity and temperature
- Compact probe for humidity and temperature measuring resp. flow rate measuring (probe exchange without re-calibration)
- Calculation of dew point temperature, dew point distance and enthalpy
- Additional NiCr-Ni-socket for surface measurement
- Min-/Max value memory, Hold function
- Serial interface, device can be connected to bus system (up to 5 devices can be connected to one PC interface)
- Battery/d.c. operation

Additional functions of the GMH3350:

- 2 integrated logger functions
- Optical and acoustic min-/max- alarm
- Real-time clock with day, month and year

GMH 3330 probe not included

GMH 3350 probe not included

Please order probes separately! (p.r.t. page 18)
(No re-calibration required for probe exchange!)

Specification:

Measuring ranges:

- Rel. humidity:** 0,0 ... 100,0 %RH
- Ambient temperature:** -40,0 ... +120,0°C (depending on TFS-probe)
- Surface temperature:** -80,0 ... +250,0°C
- Flow rate:** depending on STS probe (p.r.t. page 18)

Resolution: 0,1 %RH., 0,1 °C / 0,1 °F, 0,01 m/sec.

Accuracy (device): (±1 digit, at nominal temperature = 25°C)

Rel. humidity: ±0.1%

Ambient temperature (Pt1000): ±0,2%

Surface temperature (NiCr-Ni): ±0,5% of m.v. ±0,5°C

Flow rate: ±0,1%

Probes: (p.r.t. page 18) No calibration required for exchange of humidity/temperature or flow rate probe.

Probe connection: 6-pin screened Mini-DIN-socket

NiCr-Ni-connection: for miniature flat-pin plug

Display: two 4½ digit LCDs (12.4mm or 7mm high), as well as additional functional arrows.

Working temperature: -25 to +50°C

Relative humidity: 0 to +95%RH (non-condensing)

Storage temperature: -25 to +70°C

Pushbuttons: 6 membrane keys

Interface: serial interface, direct connection to RS232 or USB interface of a PC via electrically isolated interface adapter GRS3100 or GRS3105 resp. USB3100 (p.r.t. accessories).

Power supply: 9V-battery, type IEC 6F22 (included) as well as additional d.c. connector for external 10.5-12V direct voltage supply. (suitable power supply: GNG10/3000)

Auto-Off-Function: 1...120 min (can also be deactivated).

Power consumption: approx. 2,5 mA (incl. TFS0100)

Low battery warning: Δ and 'bAt'

Housing dimensions (device): 142 x 71 x 26 mm (H x W x D)

Impact-resistant ABS plastic housing, membrane keyboard. Front side IP65, integrated pop-up clip for table top or suspended use.

Weight: approx. 160 g (incl. battery)

Functional range:

Min-/Max-value memory: memorizing of max. and min. values for humidity, temperature, dew point etc.

Hold function: By pressing a button the current values will be "frozen".

Calculation of dew point: based upon humidity and temperature.

Calculation of dew point distance: by means of a surface meas.

Calculation of enthalpy (thermal content h of the air)

Adjustment-function for atmospheric humidity measurements

NiCr-Ni-temperature measuring: any standard NiCr-Ni-probe (type K) can be plugged in. Recommendation: GOF400VE (p.r.t. p. 123). A compensation value can be set for surface meas. if necessary.

Flow measurements:

Two different systems for averaging are integrated:

- **continuous averaging:** the average value displayed is calculated using the last measurements during the averaging time set.

- **averaging upon request:** by starting the current measuring value will be displayed for the averaging time. As soon as the time has expired the average value will be displayed, the device is in HOLD mode.

- **selectable averaging time:** 1 ... 30 seconds

Additional functions of the GMH3350:

Min-/Max-alarm: the measuring value is constantly monitored if they remain within the min./max. limits set.

- **Alarm:** 3 different alarm settings

off: alarm function not activated

on: visual alarm via display, integrated buzzer and interface

no Sound: alarm via display and interface

- **Controlling function:** with the help of the switching module GAM3000 (optionally) electric equipment can be switched on/off or alarm memoried (p.r.t. accessories)

Logger functions:

- **manually:** 99 data sets (data recall via keyboard or interface)

- **cycle:** 5.400 data sets (data recall via interface)

- **adjustable cycle time:** 1sec. ... 1h

Logger start and stop via the keyboard or interface. Comfortable read-out and display software (GSOFT3050) available as additional equipment.

Real-time clock: clock with day, month and year

Accessories:

GNG 10/3000 plug-in power supply

GKK 3500 case with cut-outs for GMH3xxx

GKK 3600 case with foam lining for universal use

USB 3100 N interface converter, electrically isolated

ST-RN device protection bag with cut out for sensor connection, suitable for: GMH3330, GMH3350

GSOFT 3050

software for the setting, data read-out and printing of all logger data stored for devices of the GMH3xxx-series with logger function

GAM 3000

Switching module for devices of the GMH3xxx-series incl. alarm output

GMH3330 incl. TFS0100E and WPF4

device incl. measuring probe, certificate of calibration and case (p.r.t. page 5)

miscellaneous accessories (case, mains adaptors, etc.)
suitable for all GMH3xxx devices p.r.t. p. 56 - 58

Meas. probes for GMH 3330 and GMH 3350

humidity / temperature



Humidity/temperature:

TFS 0100 E (0,0 ... 100,0 % r.h.)
Humidity/temperature probe, calibrated and exchangeable

Specification :

Meas. ranges:

Humidity: 0,0 ... 100,0 %RH (rec. range of application: 11...90%RH)
Temperature: -40,0 ... +120,0 °C (attention: working temperature of electronics!)

Accuracy: (at nominal temperature = 25°C)

Humidity: ±2,5 %RH
Temperature: ±0,5 °C

Sensors:

Humidity: capacitive polymer humidity sensor
Temperature: Pt1000, 1/3 DIN

Electronics: PC board with amplifier and data memory for sensor data (calibration, etc.) integrated in probe handle.

Working temperature: -25 to +60°C (handle and electronics)
-40 to +120°C (for short time up to +120°C) (sensor head and tube)

Relative humidity: 0 to +100 %RH

Dimensions: Probe tube: Ø14 x 119 mm, plastic handle: Ø19 x 135 mm, approx. 1m PVC conn. cable with 6-pin Mini-DIN-plug

Weight: approx.. 90 g

Accessories: calibration device

Humidity reference cells works on the basis of physiochemical processes. A specific value of relative humidity adjusts itself over a saturated salt solution.

The test chamber is separated from the solution by a diaphragm so that the sensor under test is protected against contamination by the solution. The test container can be used in all mounted positions.



GFN-SET1

Humidity reference cells for ~33 and ~76 %RH, probe adapter and robust carry case

GFN 33

humidity reference cell for ~33 %RH, incl. adapter

GFN 76

humidity reference cell for ~76 %RH, incl. adapter

Surface temperature:

GOF 400VE (p.r.t. page 123)
Quick-response surface probes for walls, floors etc.

GTF 300 (p.r.t. page 125)
Quick-response basic thermocouple probe for universal applications (surface measurement)

flow speed



Water:

STS 005 (0,05 ... 5,00 m/sec.)
Flow measuring probe with snap-on head, calibrated and exchangeable.

Specification :

Sensor type: windmill-type anemometer

Meas. range: 0,05 ... 5,0 m/sec.

Accuracy: ±1 % of range ±3% of meas. value (at nominal temperature)

Permiss. angle flow: ±20°, without additional meas. faults

Working temperature : 0 to +70 °C

Relative humidity: 0 to +100 %RH (non-condensing)

Dimensions: Probe head: Ø 11 x 15mm, tube: Ø 15 mm overall length 165 mm, required insertion opening: Ø 16 mm, approx. 5m PVC connection cable with 6-pin Mini-DIN-plug

Weight: approx. 75 g

Air:

STS 020 (0,55 ... 20,00 m/sec.)
Flow measuring probe with snap-on head, calibrated and exchangeable.

Specification :

Sensor type: windmill-type anemometer

Meas. range: 0,55 ... 20,00 m/sec.

Accuracy: ±1 % of range ±3% of meas. value (at nominal temperature)

Permiss. angle flow: ±20°, without additional meas. faults

Working temperature: 0 to +70 °C

Relative humidity: 0 to +100 %RH (non-condensing)

Dimensions: Probe head: Ø 11 x 15mm, tube: Ø 15 mm overall length 165 mm, required insertion opening: Ø 16 mm, approx. 5m PVC connection cable with 6-pin Mini-DIN-plug

Weight: approx. 75 g

Spare parts and accessories:

STE 005
Spare snap-on head for STS 005

STE 020
Spare snap-on head STS 020

GTS Telescopic rod (overall length 1 m)
Please specify when ordering - no retrofit assemblage possible!



picture shows GTS with assembled STS020

Humidity/Temperature Meas. Device



Digital-Hygro-/Thermometer GFTH 95

Application: quick-response humidity and temperature measurements in EDP rooms, museums, galleries, churches, office complexes, workshops, storage rooms, swimming-baths, private buildings, greenhouses, for refrigeration engineering, air conditioning, for building sites/technology, for inspectors or rendering of expert opinions etc.

Specification:

Measuring range:

°C: -20.0 ... 70.0 °C

%RH: 10 ... 95 %RH (recom. range: 30 ... 80%)

Resolution: 0.1°C or 0.1 %RH.

Accuracy: (±1 digit) (at nominal temperature = 25°C)

temperature: ±0.5% of m.v. ±0.1°C

humidity: ±3%RH (for range 30 to 80%)

Measuring probe:

temperature: Pt 1000

humidity: capacitive polymer humidity sensor

Response time: T₉₀ = 15 sec.

Display: 3½-digit, 13mm high LCD-display

Operation elements: slide switch for selection of measuring range

Nominal temperature: 25°C

Operating conditions:

Electronic: -20...70°C; 0...80 %RH (non-condensing)

Sensors: -20...70°C; 0...100 %RH

Power supply: 9V-battery type IEC 6F22 (in scope of supply)

Power consumption: max. 0.1 mA

Low battery warning: „BAT“ displayed automatically in display of low battery condition.

Housing: impact resistant ABS-housing 106 x 67 x 30 mm, plus sensor head protruding at the longer side 35 mm long and 14 mm Ø, ie. overall length 141 mm.

Weight: approx. 135 g incl. battery

Accessories:

GKK 252 case
(235 x 185 x 48 mm) with foam lining

GKK 1100 case
(340 x 275 x 83 mm) with foam lining

GB 9 V spare battery

Certificate of calibration WPF4
for ISO9000ff (p.r.t. page 4)

Humidity / Temperature / Dew Point Measuring Device



Digital-Hygro-/Thermometer GFTH 200

GFTH 200 SET (incl. infra-red thermometer GIM 530 MS)

Because of the low power consumption and the integrated min-/max-value memory the **GFTH200** is perfectly suitable for long term climate surveillances.

The additional infrared thermometer contained in the GFTH 200 SET makes it easy to check mould-problem areas on walls etc. The wall can easily scanned by means of the laser beam within very short time. When wall temperature falls below the critical dewpoint (this is, when the wall gets wet), the device alerts with an audible signal.

Advantages GFTH 200:

- relative humidity, temperature and dew point in just one instrument
- high accuracy by means of digital works calibration
- min-/max-value memory for all measurements
- external Pt1000 temperature probe connectable
- offset and slope correction for easy adjustment
- extrem low power consumption

Additional advantages GFTH 200 SET:

- blindingly easy search for thermal bridges
- targeting laser for precise location even of inaccessible areas
- audible alarm below dewpoint
- fast evaluation of mould-problem areas

Specification:

Measuring range:

Temp: -25.0 ... +70.0 °C; -13.0 ... +158.0 °F

%RH: 0.0 ... 100.0 %RH
(recommended range: 11 - 90 %RH)

Td: (Dewpoint) -40.0...+70.0 °C or -40.0...+158.0 °F

Resolution: 0.1 %RH., 0.1°C or 0.1°F

Accuracy: (±1 digit) (at nominal temperature = 25°C)

temperature (internal): ±0.5% of m.v. ±0.1°C

temperature (external): 0.1°C (device) + probe accuracy

humidity: ±2.5 %RH (for range 11 to 90%)

Measuring probe:

temperature: Pt 1000

humidity: capacitive polymer humidity sensor

Response time: T₉₀ = 10 sec.

terminal for external probe: for connection of any Pt1000-probes with 3.5mm mono plug (for suitable probes p.r.t. page 122)

Display: 3½-digit, 13mm high LCD-display

operation elements: 3 keys for On/Off, min-/max-value display and hold. Slide switch for selection of measuring range.

Nominal temperature: 25°C

Operating conditions:

Electronic: -25...70°C; 0...80 %RH (non-condensing)

Sensors: -25...70°C; 0...100 %RH



Measuring set

Power supply: 9V-battery type IEC 6F22

Power consumption:

approx. 9µA at 1 measurings / 60s

approx. 100µA at 1 meas. / sec. (mode FAST)

Low battery warning: „BAT“

Min./max. value memory: Min and Max measuring values are stored for all 3 ranges.

Hold key: The current measuring will be "frozen" (for all three ranges).

Housing: impact resistant ABS-housing 106 x 67 x 30 mm, plus sensor head protruding at the longer side 35 mm long and 14 mm Ø, ie. overall length 141 mm.

Weight: approx. 135 g incl. battery

GIM 530 MS: for technical data for this instrument please refer to page 13.

Accessories:

GKK 252 case
(235 x 185 x 48 mm) with foam lining

GOF 175 Mini temperature probe
for surface temperature measuring (p.r.t. page 122)

further temperature probe refer to page 122

Certificate of calibration WPF4
for ISO9000ff (p.r.t. page 4)

GFTH200 - WPF4 complete-offering
device incl. certificate of calibration and case (p.r.t. p. 5)

Precision Hygro- / Thermo- / Barometer



- relative humidity, temperature and air pressure in just one instrument
- additional derived units: dew point temperature, wet bulb temperature, moisture content and absolute humidity
- min-/max-value memory for all measurements
- high accuracy by means of digital works calibration
- offset and slope correction for easy adjustment
- extreme low power consumption
- optional with serial interface

Application: Quick-response measurement of air pressure, atmospheric humidity, temperature and further derived units in EDP rooms, museums, churches, administrative and residential buildings, storage rooms, green houses, pools, production rooms, for cooling technology and air conditioning as well as for building engineers and for the evaluation of damage to buildings etc. Due to highly accurate sensors this device has a notably higher precision than comparable devices. Via the additional displaying possibilities ('dew point temperature Td', 'wet bulb temperature Twb', 'absolute humidity [g/m³]' and 'moisture content of the air [g/kg]') the current state of the air is precisely and concretely shown. Due to the low power consumption, the device can be run permanently, for example as "weather station".

Digital-Hygro-/Thermo-/Barometer

GFTB 100

Specification:

Measuring range:

temperature: -25.0 °C ... +70.0 °C or -13.0 ... +158.0 °F
humidity: 0.0 ... 100.0 %RH (recommended range: 11 ... 90 %RH)
air pressure: 10.0 ... 1100.0 mbar

derived units:

dew point temperature Td: -40.0 ... 70.0 °C or -40.0 ... +158.0 °F
wet bulb temperature Twb: -27.0 ... 70.0 °C or -16.6 ... +158.0 °F
moisture content x: 0.0 ... 280.0 g/kg
absolute humidity d: 0.0 ... 200.0 g/m³

Resolution: 0.1%RH, 0.1°C/°F, 0.1mbar

Accuracy: (±1 digit) (at nominal temperature = 25°C)
temperature: ±0,5 % of m.v. ±0,1°C (Pt1000 1/3 DIN B)
humidity: ±2,5 %RH (at range 11 to 90%)
air pressure: ±1,5 mbar (750...1100 mbar)

Measuring probe:

temperature: Pt1000
humidity: capacitive polymer humidity sensor
air pressure: piezoresistive pressure sensor hybrid

Response time: T₉₀ = 10 sec.

Display: 4½-digit, approx. 11mm high LCD-display

Operation elements: 3 keys for ON/OFF, min-/max-value display, hold

Nominal temperature: 25°C

Operating conditions:

Electronics: -25...70 °C; 0...80 %RH (non-condensing)
Sensors: -25...70 °C; 0...100 %RH

Power supply: 9V-battery type IEC 6F22

Power consumption: approx. 30µA at 1 meas. / 60s (mode SLOW)
approx. 70µA at 1 measurings / sec. (mode FAST)

Low battery warning: „BAT“

Auto-off function: when Auto Off is activated, the device switches automatically off, if keypad is not attended for a longer time (selectable 1..120min).

Interface (optional): serial interface, direct connection to RS232 or USB interface of a PC via electrically isolated interface converter GRS3100 o. GRS3105 resp. USB3100 (accessories).

Min./max. value memory: Min and Max measuring values are stored for all ranges.

Hold key: the current measuring will be "frozen" (for all ranges)

Configurable display: The device can be configured by the user: display all measuring values alternating (2 or 4 sec. Cycle) or permanent with manual choice. Not required values can be suppressed.

Sea level adjustment: The displayed value of the barometer can be converted to air pressure at sea level. (therefore the altitude above sea level has to be entered)

Tendency indicator (for barometer): air pressure falling/increasing

Offset and Scale: digital offset- and scale adjustment of all sensors

Housing: impact resistant ABS-housing
approx. 106 x 67 x 30 mm (H x W x D), plus sensor head protruding at the longer side 35 mm long and 14 mm Ø, ie. overall length 141 mm.

Weight: approx. 130g incl. battery

Options: (upon upcharge)

- **GRS** serial interface
(ordering description: GFTB 100 / GRS)
- **KIT** USB-interface kit, consisting of:
 - interface option "GRS" for the GFTB 100
 - USB interface converter **USB 3100 N**
 - multi channel software **EBS20M** (to record all device units)
(ordering description: GFTB 100 / KIT)

Complete-offering:

GFTB 100 SET

(GFTB100 incl. infra-red thermometer GIM 530 MS)



The additional infrared thermometer contained in the **GFTB 100 SET** makes it easy to check mould-problem areas on walls etc.

The wall can easily be scanned by means of the laser beam within very short time. When wall temperature falls below the critical dewpoint (this is, when the wall gets wet), the device alerts with an audible signal.

Additional advantages GFTB 100 SET:

- blindingly easy search for thermal bridges
- targeting laser for precise location even of inaccessible areas
- audible alarm below dewpoint
- fast evaluation of mould-problem areas

Note: for technical data for the infra-red thermometer GIM530MS please refer to catalog page 13.

Accessories:

GKK 252 case (235 x 185 x 48mm) with foam lining

WPF4 Certificate of calibration, humidity, for ISO9000ff (p.r.t. p. 4)

WPD5 Certificate of calibration, pressure, for ISO9000ff (p.r.t. p. 4)

miscellaneous accessories p.r.t. page 56 - 58

Material moisture handheld instruments



Application:	Device	GMK 210	GMK 100	GMI 15	GMR 100	GMH 3810	GMH 3830 + passende Elektrode	GMH 3850 + passende Elektrode
Carpenter, joiners			✓	✓	✓	✓	✓	✓
DIY / Hobby			✓	✓	✓	✓	✓	✓
Boot & Caravan (Holz & GFK)		✓						
Certified glue lam							✓	✓
Foelwood, wooden log					✓	✓	✓	✓
Wood chips							✓	✓
Plaster, screed			✓	✓	✓	✓	✓	✓
Concrete, bricks, lime mortars			✓	✓	✓	✓	✓	✓
Construction-damage assessment			✓	✓	✓	✓	✓	✓
Water damage restoration			✓	✓	✓	✓	✓	✓

Function / Equipment:	Device	GMK 210	GMK 100	GMI 15	GMR 100	GMH 3810	GMH 3830	GMH 3850
Specification								
Method		capacitive (non-destructive)			resistive (Resistance)			
Sensor / Probe		integrated			integrated	external		
Meas. range		material moisture: 0 ... 100%		--	material moisture: 0 ... 100%			
Characteristics		14	18		4	494		
Programmabel user curves								4
Functions								
General functions		Hold, Auto-Off	Hold, Auto-Off		Hold, Auto-Off	Hold, Auto-Off, Sort	Hold, Auto-Off, Sort	Hold, Auto-Off, Sort
Interface						✓	✓	✓
Alarm							0 ... 1 V, freely adjustable	0 ... 1 V, freely adjustable
Data logger								✓
Catalog page		p. 23	p. 23	p. 22	p. 25	p. 25	p. 24	p. 25

Handheld instrument

Display / Controller

Logger / EASYBus

Transmitter

Temperature probe

Alarm / Protection

Material Moisture Measurement with GREISINGER handheld instruments

• Resistive measuring method (GMR 100, GMH 3810, GMH 3830, GMH 3850)

The electrical resistance often depends on the material moisture. Therefore the devices measure the (possibly extremely high) values of resistance and convert them to the displayed value by means of integrated characteristic curves. The temperature has to be compensated especially at the measurement of wood – all GREISINGER-instruments have an integrated temperature compensation. In most cases the contact is realised by nails that are driven into the material are used to contact.

• Capacitive measuring method (GMK 210, GMK 100, GMI 15)

The dielectric properties of an object are often a good indicator for its material moisture. The dielectric coefficient of water is considerably higher than that of dry lumbers or building materials. Therefore the total dielectric coefficient of the measuring object can be easily used to get its material moisture. For the measurement the device has to be applied on the material. Precondition therefore: planar surfaces, no metallic elements.

Another method is to measure the material moisture indirectly by means of the **relative humidity** (i.e. with GMH 3330 + TFS 0100 E): The humidity in a sealed hole within a material depends on the material moisture. By means of a so-called sorption isotherm or a corresponding table the material moisture can be calculated from the humidity.

The **oven dry method** can be used for reference point measurement with highest accuracy.

The moist material is weighed and afterwards dried at increased temperature until no weight loss is detectable anymore. The material moisture can be calculated from the moist and arid weight.

Units

- Material moisture u (also „atro“): relating to dry mass

$$\text{material moisture } u [\%] = \frac{(\text{mass wet} - \text{mass dry})}{\text{mass dry}} * 100$$

Particularly important for carpenters, joiners, etc.

- Moisture content w : material moisture related to wet total mass

$$\text{moisture content } w [\%] = \frac{(\text{mass wet} - \text{mass dry})}{\text{mass wet}} * 100$$

Particularly important for the evaluation of combustibles.

- “Digit“ (GMI 15)

The displayed value is relative, that means without a physical unit.

This can be used to get comparative moisture information of the same materials. Lower values indicate less moisture, higher values indicate therefore more moisture.

For further information on this topic please see the devices' manuals and our homepage www.greisinger.de under Download -> Documents

Capacitive moisture detection

without damaging of material up to 4 cm of depth



Indicator for moisture in wood and buildings

GMI 15

Device for high-speed determination of moisture in buildings, contracting work etc.

The GMI 15 allows detection of moisture in wood down to a depth of approx. 3 cm and in concrete or wash floor down to a depth of approx. 4 cm. Detection of moisture behind ceramic tiles and/or various wall or floor coverings. To check moisture simply place device on the surface to be measured - no injection into the measuring object required.

Application:

Humidity indication for i.e. estate agents (for fast control state of buildings), property management, house owners, architects, building experts, building contractors, mobile homes (moist in insulations), polyester / GRP boats

Note: The GMI 15 is an indicator for the fast estimation - it does not replace precision instruments like the GMH 3810, GMH 3830 and GMH 3850

Specification:

Display: 3½-digits, 13 mm high LCD
Power supply: 9V-battery (type IEC 6F22)
Power consumption: approx. 5 mA
Low battery warning: „BAT“ displayed automatically in case of low battery.
Working temperature: 0 to 50 °C
Storage temperature: -20 to +70 °C
rel. humidity: 0 to 80 %RH (non-condensing)
Housing: Impact resistant ABS plastic housing, approx. 106 x 67 x 30 mm (H x W x D). approx. 150 g (ready for use)

Weight:

Display range:

concrete / floor pavement

0 ... 5 = dry
 6 ... 9 = humid, normal humidity level
 10 ... = wet

wood / fibre glass reinforced polyester

0 ... 3 ~ 0...12% : dry
 3 ... 6 ~ 12...20% : air-dry
 6 ... 11 ~ 20...30% : wind-dry
 11 ... ~ 30% ... : wet

Capacitive moisture measurement and moisture rating

without damaging of material, 2 measurement depth



Measuring device moisture in wood and buildings

GMK 100

The GMK 100 is a capacitive material moisture measuring device with direct moisture display in percent. It is optimally suited for home and handcraft. Depending on the application, it is possible to display the material moisture "u" or the water content "w".

The humidity is measured by a measuring plate on the back of the device. With a side-mounted switch the measuring depth can be changed. With the help of measurements in different depth a statement could be made if for example the material dries already or if the moisture is just on the surface of the material.

Application:

Humidity measurement and indication of Wood, Concrete, Screed, Plaster, etc.

Features:

- Non-destructive measurement
- Moisture display in percent
- Acoustical and visual moisture rating
- 18 material characteristics for wood and building materials
- 2 different measurement depth
- Backlight

Specification:

Display:	2 displays for material and measured value, backlight
Moisture rating:	
Visuel:	Rating of the moisture in 6 levels from WET to DRY
Akustisch:	Signal tone
Measurement depths:	10 mm and 25 mm
Materials:	18 characteristic curves for wood and popular materials, additionally reference curve for high-resolution relative measurements
Working temperature:	-25 to 50 °C
Storage temperature:	-25 to 70 °C
Power supply:	9V-battery (Type IEC 6F22)
Power consumption:	approx. 0,12 mA
Power backlight:	approx. 2,5 mA
Functions:	Used-battery-display, Auto-Off-Function, Hold
Housing:	Impact-resistant ABS plastic housing, front: IP65, approx. 106 x 67 x 30 mm (H x W x D).
Weight:	approx. 135 g (incl. battery)

Accessories:

PW 25

Testing probe to control the device.

Capacitive moisture measurement and moisture rating

without damaging of material, 2 measurement depth



CARAVAN and BOAT

GMK 210

The GMK 210 is a capacitive material moisture measuring device with direct moisture display in percent. It is optimally suited for home and handcraft. Depending on the application, it is possible to display the material moisture "u" or the water content "w".

The humidity is measured by a measuring plate on the back of the device. With a side-mounted switch the measuring depth can be changed. With the help of measurements in different depth a statement could be made if for example the material dries already or if the moisture is just on the surface of the material.

Application:

Humidity measurement and indication of Wood, GFK (glass fiber reinforced plastic)

Features:

- Non-destructive measurement
- Moisture display in percent
- Acoustical and visual moisture rating
- 14 material characteristics for wood and GFK
- 2 different measurement depth
- Backlight

Specification:

Display:	2 displays for material and measured value, backlight
Moisture rating:	
Visuel:	Rating of the moisture in 6 levels from WET to DRY
Akustisch:	Signal tone
Measurement depths:	10 mm and 25 mm
Materials:	14 characteristic curves for wood (with assignment label for wood species) and GFK; additionally reference curve for high-resolution relative measurements
Working temperature:	-25 to 50 °C
Storage temperature:	-25 to 70 °C
Power supply:	9V-battery (Type IEC 6F22)
Power consumption:	approx. 0,2 mA
Power backlight:	approx. 2,5 mA
Functions:	Used-battery-display, Auto-Off-Function, Hold
Housing:	Impact-resistant ABS plastic housing, front: IP65, approx. 106 x 67 x 30 mm (H x W x D).
Weight:	approx. 145 g (incl. battery)

Accessories:

PW 25

Testing probe to control the device.

Precision Material Moisture Meas. Device

for wood, building material, straw, hay, paper, textiles etc.

MPA certified
appr. for glued timber construction
acc. to DIN 1052-1



- 466 wood characteristic curves
- 28 building material characteristic curves
- moisture estimation
- display of moisture content u or wet-basis moisture content w
- external temperature probes connectable
- serial interface or analog output 0-1V, freely adjustable
- Future-proof via updates

Description: the GMH3830 offers important advantages in handling, user-friendliness, functional range and accuracy for your metrological work.

The absolute moisture content of 494 materials is displayed directly. The cumbersome usage of calculation tables now is history. Additionally you get a evaluation of your material state (wet/dry) of nearly all materials instantly. Of course the formerly used wood groups A, B, C and D of the predecessor models are further more supported.

GMH 3830 access. not included

Resistive material-moisture and temperature measuring device

General application: precision measurements in cut wood, chip board, veneer, sawdust, wood chips, wood wool, flax, straw, hay, concrete, gas concrete, bricks, wash floor, cast, limestone mortar, cement mortar, paper, carton, textiles etc.

User: architect, expert, inspector, building contractor, painter, carpenter, parquet joiner, floor tiler, wood works, timber desiccation plant, building repair company, textile industry etc.

Specification GMH 3830:

Measuring principle:

moisture: resistive material-moisture-measuring matching DIN EN 13183-2:2002
temperature external: thermocouple, NiCr-Ni (type K)
temperature internal: NTC

Characteristic curves: 494

Measuring range:

moisture: 0,0 to 100,0 % moisture content (depending on characteristic curve)
temperature: -40,0...+200,0°C (-40,0...+392,0°F)

Estimation: in 9 steps (dry ... wet)

Resolution: 0,1% resp. 0,1°C (0,1°F)

Accuracy device: (at nominal temperature)

wood: $\pm 0,2$ % moisture content (deviation from characteristic curve at range 6...30%)
building mat.: $\pm 0,2$ % moisture content (deviation from characteristic curve)
temperature (external): $\pm 0,5\%$ v. MW $\pm 0,3$ °C

Temperature compensation: automatically or manual

Sensor connection:

moisture: BNC
temperature: flat pin plug (free of thermo-voltage)

Perm. working temperature: -25 to 50 °C

Display: two 4 digit LCDs (12.4mm or 7mm high), as well as additional arrows.

Pushbuttons: 6 membrane keys

Output: 3-pin jack connector $\varnothing 3,5$ mm, choice between serial interface or analog output

- **serial interface:** direct connection to RS232 or USB interface of a PC via electrically isolated interface adapter GRS3100 or GRS3105 resp. USB3100 (p.r.t. accessories).

- **analog output:** 0...1V, freely adjustable

Power supply: 9V-battery, additional d.c. connector for external 10.5-12V direct voltage supply (suitable power supply: GNG10/3000).

Power consumption: approx. 2.5 mA

Dimensions / Weight: 142 x 71 x 26 mm, 155 g

Housing: Impact-resistant ABS plastic housing, membrane keyboard, transparent panel. Front side IP65, integrated pop-up clip

Functions:

Hold, Auto-Hold (automatic freezing of a constant value), **Low battery warning** (Δ and ' bAt '), **Sort** (limitation of the choice of materials to up to 8 favourites), **Auto Power Off**

GMH 3830 LW:

Complete material moisture measuring set optimized for use in agriculture



The set consists of GMH 3830 with preset material selection (Sort) and a rugged integrated probe (15) with integrated temperature sensor.

The set is excellently suitable for measuring in hay bales and bulk goods. Putting the probe into the medium, material moisture and temperature could be specified quick and easy.

Scope of Supply:

1x GMH 3830 (measuring device incl. battery), 1x GSF 38TF (injection probe), 1x BNC connection cable 1.5m, 1x NiCr-Ni connection cable 1.5m, 1x GKK 3500 (Koffer)

Accessories:

SET 38 HF (Wood moisture set)



contents: GKK3500 (case), GMK 38 (measuring cable), GSE 91 (impact electrode), GST 91 (steel nails), GTF38 (temperature probe)

SET 38 BF (Wood a. building material moisture set)



contents: GKK3500 (case), GMK 38 (measuring cable), GSE 91 (impact electrode), GST 91 (steel nails), GTF38 (temperature probe), GMS300/91 (measuring pins), GBSK91 (brush-type probe), GLP 91 (conducting paste)

SET 38 MPA (MPA wood moisture set)

contents: as SET38HF but instead of GSE 91 with GHE 91

USB 3100 N interface converter

GNG 10/3000 power supply

miscellaneous accessories p.r.t.p. 56 - 58

Accessories, spare parts:

- GMK 38**
measuring cable (BNC to 2 x banana plug) approx. 90cm long
- GHE 91**
reciprocating piston electrode
- GSE 91**
impact electrode
- GEG 91**
handle for retrofit of impact electrode
- GSG 91**
retrofitted impact electrode with front side of GSE 91 and handle GEG91
- GST 91**
steel nails (3 pieces each 12, 16 and 23 mm long) in plastic case
- GOK 91**
surfaces-measuring caps (pair) (to be screwed on GSG91 or GSE91)
- GMS 300/91**
measuring pins 300 mm long (pair) for wood chips, wood wool, paper, carton, etc. (to be screwed on GSG91 or GSE91)
- GBSK 91**
short brush-type probe (pair) for depth down to approx. 100 mm
- GBSL 91**
long brush-type probe (pair) for depth down to approx. 300 mm
- GLP 91**
conducting paste 100 ml, for surface measurements and depth indication in walls, wash floors etc. with brush probes
- GSP 91**
sensor for surface measurements on paper, textiles etc.
- GSP 91 ES**
spare sensor element for GSP 91
- GSF 38 (1 m)**
GSF 38K (25 cm)
injection probe (diff. meas. depths) with handle and 1.5 m connection cable (for bales of wood wool, wood chips etc.)
- GSF 38TF (1 m)**
GSF 38TFK (35 cm)
injection probe (diff. meas. depths) with integrated NiCr-Ni-temperature probe, with handle and connection cables (for bales of wood wool, wood chips, hay bales, bulk goods, etc.)
- GEF 38**
flat electrode (for floor pavement, etc.)
- GPAD 38**
testing adapter (with 2 test points)
- GTF 38**
insulated NiCr-Ni temperature probe, $\varnothing 2,2 \times 25$ mm (necessary for temperature differences between wood an device)
- GES 38**
insulated NiCr-Ni injection probe (e.g. for wood chips), $\varnothing 4 \times 150$ mm
- GKK 3500**
case (394 x 294 x 106 mm) with punched lining for device an access.
- ST-RN**
protection pocket with openings for sensor connections (suitable for GMH 3830, GMH 3850)

pict.: GMH3830 in ST-RN

Measuring material moisture with data logger and user programmable material curves



MPA certified
appr. for glued timber construction
acc. to DIN 1052-1

Resistive material-moisture meas. device

GMH 3850 with data logger

This instrument is indispensable for the documentation of material state by quality assurance systems.

By means of the integrated data logger there can be recorded up to 10000 measuring values and processed on demand. Additionally there can be 4 material curves individually programmed by the user to data acquired by reference measurements with dry ovens or CM-method.

This instruments finally makes the usage of paper correction tables and so on obsolete.

Specification:

Measuring principle:

moisture: resistive material-moisture-measuring matching DIN EN 13183-2:2002
temperature external: thermocouple, NiCr-Ni (type K)
temperature internal: NTC

Characteristic curves: 498

Sensor connection:

moisture: BNC
temperature: flat pin plug (free of thermo-voltage)

**Identical technical data like GMH3830
plus following features:**

Logger functions:

-manually: 99 data sets (visualisation via keys/
display or interface)

-cyclic: 10000 data sets (visualisation via
interface)

-adjustable cycle time: 30sec ... 1h

Logger start and stop via the keyboard or interface. Comfortable read-out and display software (GSOFT3050) available as additional equipment.

Real-time clock: clock with day, month and year

User curves: 4, programmable via interface

20 interpolation points per curve

By means of the gratis software GMHKonfig the interpolation points can be comfortably edited and stored to the instrument. To connect the instrument to a PC one of the interface converters mentioned below is needed.

Accessories:

SET 38 HF wood moisture set

SET 38 BF wood and building material moisture set

GSOFT 3050 logger software

GRS 3100 RS232 interface converter

USB 3100 N interface converter

GKK 3500 case (394 x 294 x 106 mm)
with punched lining for device of the GMH3xxx-series

miscellaneous accessories p.r.t. pages 56 - 58

The handy alternative for wood and building material moisture measuring



Resistive material-moisture meas. device

GMH 3810 with integrated measuring pins

The measuring pins integrated on the reinforced front numerous measurements can be done without additional accessories.

For measuring of very hard materials we suggest the components shown at the accessories section.

Specification:

Measuring principle:

moisture: resistive material-moisture-measuring matching DIN EN 13183-2:2002
temperature internal: NTC

Characteristic curves: 494

Measuring range:

moisture: 0,0 to 100,0 % moisture content
(depending on characteristic curve)
temperature: -40,0...+200,0°C (-40,0...+392,0°F)

Estimation: in 9 steps (dry ... wet)

Resolution: 0,1% resp. 0,1°C (0,1°F)

Accuracy device: (at nominal temperature = 25°C)

wood: ±0,2 % moisture content
(deviation from characteristic curve at range 6...30%)
building mat.: ±0,2 % moisture content
(deviation from characteristic curve)

Temperature compensation:

automatically or manual

Measuring probe: 2 pin holders M6*0.75 with
19mm pins (12mm utilisable)

Perm. working temperature: -25 to 50°C

Storage temperature: -25 to +70°C

Relative humidity: 0 to +95%RH (non-condensing)

Display: two 4-digit LCDs

Power supply: 9V-battery, type IEC 6F22

Power consumption: approx. 2.5 mA

Dimensions / Weight: 142 x 71 x 26 mm, 175 g

Housing: Impact-resistant ABS plastic housing,
membrane keyboard, transparent panel. Front
side IP65, integrated pop-up clip

Functions: Hold, Auto-Hold, Sort, Auto
Power Off (description refer to GMH3830)

Accessories:

GST 3810 replacement pins (10 pcs.)

GMK 3810



1 m measuring cable, incl. adapter
(2 x banana plug to 2 x banana plug)
Allows connection of accessories

GSE 91 impact electrode

for additional accessories p.r.t. page 24

miscellaneous accessories p.r.t. pages 56 - 58

The "little brother" for wood and building material moisture measuring



Resistive material-moisture meas. device

GMR 100 with integrated measuring pins

Small, compact measuring instrument for easy measurement of cut wood, chip, veneer, fire wood, wood briquettes, plaster, gypsum,

- Integrated, **exchangeable** measuring needles
- **4 popular wood groups A, B, C, D, construction materials E, plaster P**
- **Direct display of moisture content u or wet basis water content w**

Specification:

Measuring principle: resistive material-moisture-measuring matching DIN EN 13183

Characteristic curves: 4 different wood groups (A, B, C, D) for a total of 130 kinds of wood, one universal construction material group E (tables), one construction material group P = Plaster

Meas. range: 0,0 to 100 % moisture content
(depending on characteristic curve)

Estimation: in 6 steps (dry...wet)

Resolution: 0,0 ... 19,9 %: 0,1% moisture content
20 ... 100 %: 1% moisture content

Device accuracy: (at nominal temperature = 25 °C)

wood: ±0,2 % moisture content
(deviation to wood group characteristic curve, range 6...20%)
construction: ±0,2 % moisture content
(deviation from construction curve)

Temperature compensation: manual

Measuring probe: 2 pin holders M6x0,75
with 19mm pins (12mm utilisable)

Perm. working temperature: -25 to 50°C

Storage temperature: -25 to +70°C

Relative humidity: 0...95 %RH (non-condensing)

Display: 4½-digit LCD-display with additional segments

Power supply: 9V-battery, type IEC 6F22

Power consumption: approx. 1.8 mA

Housing: impact resistant ABS, membrane keyboard, transparent panel, front side IP65

Dimensions: 110 x 67 x 30 mm + needles 26 mm
Weight: approx. 155 g

Functions: Hold, Auto-Hold, Auto Power Off

Accessories:

GST 3810 replacement pins (10 pcs.)

GMK 3810 measuring cable incl.
adapters

for additional accessories p.r.t. page 24

GKK 252 case (235 x 185 x 48 mm)
with foam lining

GB 9 V spare battery

miscellaneous accessories p.r.t. pages 56 - 58

Conductivity handheld instruments



Application:	Device	GMH 5430	GMH 5450	GMH 3430	GLF 100	GLF 100 RW
Waters measuring, fishkeeping, aquafarming (fresh- / marine waters)		✓	✓	✓	✓	
Drinking water-, process monitoring, ground measurements		✓	✓	✓	✓	
Cleaning processes		✓	✓	✓	✓	
Pure and ultrapure water		✓	✓			✓
Food production and -control		✓	✓	✓	✓	
Quality management		✓	✓	✓	✓	
Data storage			✓			
Water-proof application		✓	✓			

Function / Equipment:	Device	GMH 5430	GMH 5450	GMH 3430	GLF 100	GLF 100 RW
Specification						
Meas. range Conductivity		0,0..4,000 $\mu\text{S/cm}$ bis 0..1000 mS/cm (5 ranges available) depends on electrode	0,0..4,000 $\mu\text{S/cm}$ bis 0..1000 mS/cm (5 ranges available) depends on electrode	0,0..200,0 $\mu\text{S/cm}$ bis 0,0..200,0 mS/cm (4 ranges available)	0..2000 $\mu\text{S/cm}$ bis 0,0..100,0 mS/cm (3 ranges available)	0,000..2,000 $\mu\text{S/cm}$ bis 0,0..100,0 $\mu\text{S/cm}$ (3 ranges available)
Resistance		0,005..100,0 $\text{K}\Omega\text{m/cm}$	0,005..100,0 $\text{K}\Omega\text{m/cm}$	0,005..100,0 $\text{K}\Omega\text{m/cm}$	--	0,01..20,00 $\text{M}\Omega\text{m/cm}$
TDS		0..1999 mg/l	0..1999 mg/l	0..1999 mg/l	0..2000 mg/l	--
Salinity		0,0..70,0	0,0..70,0	0,0..70,0	0,0..50,0	--
Temperature		-5,0..+150,0 $^{\circ}\text{C}$	-5,0..+150,0 $^{\circ}\text{C}$	-5,0..+100,0 $^{\circ}\text{C}$	-5,0..+100,0 $^{\circ}\text{C}$	-5,0..+100,0 $^{\circ}\text{C}$
Sensor connection		7-pole bayonet	7-pole bayonet	fixed connection	fixed connection	fixed connection
Electrode		not included	not included	2-pole graphite electrode	2-pole graphite electrode	2-pole stainless steel electrode
Functions						
General functions		Min/Max, Hold, Auto-Off,	Min/Max, Auto-Off, Hold, Calibration memory	Min/Max, Hold, Auto-Off,	Min/Max, Hold, Auto-Off,	Min/Max, Hold, Auto-Off,
Interface		✓	✓	✓		
Alarm			✓			
Data logger			✓			
Catalog page		p. 28-29	p. 28-29	p. 30	p. 27	p. 27

Conductivity measuring devices



Highlights:

- 3 conductivity measuring ranges
- Low power consumption
- Automatic measuring range change-over
- Min/max-value memory
- Automatic temperature compensation via integrated temperature sensor
- Hold function
- Adjustable



Area of application:

- Fresh and sea water aquaristics
- Fish farming / water monitoring
- Drink water monitoring, etc.



Area of application:

- Checking of pure and ultra-pure water
- Checking of boiler water
- Functional check of ion exchangers

GLF 100 Universal conductivity measuring device

GLF 100 RW Conductivity meter for ultra-pure water

Specification	GLF 100	GLF 100 RW
Measuring ranges:		
Conductivity:	0 ... 2000 µS/cm 0.00 ... 20.00 mS/cm 0.0 ... 100.0 mS/cm	0.000 ... 2.000 µS/cm 0.00 ... 20.00 µS/cm 0.0 ... 100.0 µS/cm
Temperature:	-5.0 ... +100.0 °C	-5.0 ... +100.0 °C
TDS:	0 ... 2000 mg/l	--
Salinity:	0.0 ... 50.0	--
Resistivity:	--	0.0100 ... 0.2000 MΩ*cm 0.010 ... 2.000 MΩ*cm 0.01 ... 20.00 MΩ*cm
Accuracy: (±1 digit, at nominal temperature = 25 °C)		
Conductivity:	±0.5 % of m.v. ±0.5 % FS	typ. ±1% of m.v. ±0.5 % FS
Temperature:	±0.3 °C	±0.3 °C
Temp.-compensation:	off: deactivated nLF: non-linear, acc. to EN 27888 --	off: deactivated nLF: non-linear, acc. to EN 27888 LIN: linear, with adjustable coefficients NaCl: compensation for weak NaCl-solutions acc. to EN 60746-3
Reference temperatures:	20 and 25 °C	20 and 25 °C
Measuring cell:	2-pole measuring cell, Ø 12 mm (graphite) Cable length: 1,2 m with integrated temperature sensor with integrated temperature sensor warranty for sensor element: 12 months approx. 11 mm high, 4½-digit LCD-display	2-pole measuring cell, Ø 12 mm (stainless steel: 1.4404, 1.4435) Cable length: 1,2 m

Display:

Working conditions

- Device: -25 ... +50 °C, 0 ... 95 % RH (non condensing)
Measuring cell: -5 ... +80 °C (for short-time: 100 °C)

Power supply:

9V-battery, type 6F22 (in scope of supply)

Power consumption:

< 1.5 mA

Housing:

impact resistant ABS, membrane keyboard, transparent panel, front side IP65

Dimensions (device):

110 x 67 x 30 mm (H x W x D)

Weight:

approx. 155 g

Device functions:

Hold function:

by keypress the current measuring value will be "frozen"

Min/max-value memory:

the min. and max. measured value is stored

Power-Off-function:

device turns off after some time (adjustable: 1-120 min or deactivated), if no operating has taken

The measuring cell

The measuring head is designed without compromise. The holes ensure the well exchange of the measuring fluid, nonetheless the sensor is protected against mechanical loads. The integrated temperature sensor has very quick response time. Compared to simpler electrode designs the measurements are much more accurate and faster.

GLF 100:

Graphite used as material for the electrodes makes the applicability up to 100 mS/cm possible – a must have in seawater analytic

GLF 100 RW:

Universal applicability at highest standards is made possible by the use of stainless steel electrodes (1.4404, 1.4435).

Option

- **LTG** (just with GLF 100)

for organic matter (alcohol, petrol, diesel)
up to max. 1000 µS/cm

with glass shaft, unplatinized,
1,35 m PUR-cable, fix connected with device

Accessories

GKL 100 Conductivity control solution (100 ml bottles with 1413 µS/cm. (acc. to DIN EN 27888))

GKL 101 Conductivity control solution (250 ml bottles with 84 µS/cm.)

GKL 102 Conductivity control solution (100 ml bottles with 50 mS/cm.)

① **GEH 1** Swivel-arm electrode-retainer (for up to 4 electrodes / probes)

GWZ-01 Flow-through chamber (for measuring cell with Ø 12 mm, hose connection Ø 6 mm)

for additional accessories p.r.t.p. 56 - 58



Water-proof handheld device for conductivity measurement with external electrodes

Features

- Water-proof
- Serial interface and analog output
- Data logger and alarm function
- Measurement of conductivity, resistance, salinity, TDS
- Robust silicone protection cover
- Large double display
- Background illumination

Application

Mobile use for:

- industry and craft
- measurements of waters and aquaristics
- fish farming
- drinking water monitoring, process control, soil measurements
- food production and control
- quality management

Additional applications at laboratory:

- medicine, pharmacy, chemistry



GMH 5430 without electrode

Available from the 2nd quarter of 2012

GMH 5450 analog output and data logger, without electrode

Available from the 2nd quarter of 2012

Specifications GMH 5430 and GMH 5450

Measuring range:

Number of meas. Ranges:	5
<i>smallest range:</i>	0.000 ... 4.000 µS/cm* or 0.0 ... 400.0 µS/cm**
<i>biggest range:</i>	0 ... 4000 µS/cm* or 0 ... 1000 mS/cm**
Resistivity:	0.005 ... 100.0 kOhm/cm (depends on cell constant)
TDS:	0 ... 1999 mg/l cm (depends on cell constant)
Salinity:	0.0 ... 70.0 (g salt / kg water equals PSU = Practical Salinity Unit)
Temperature:	-5.0 ... +150.0 °C, Pt1000 or NTC (10k)

Supported cell constants:

0.1000 ... 1.2000 / cm - 0.01000 ... 0.12000 / cm - 0.001000 ... 0.012000 / cm

Accuracy (at nominal temp. 25 °C):

Conductivity:	±0.05 % of m.v. ±0.3 % FS (depends on electrode)
Temperature:	±0.2 K

Connection:

Conductivity, temperature:	1x 7-pole bayonet socket for connection of different measuring cells supported temperature sensors: Pt1000 or NTC (10k)
Interface / ext. supply:	4-pole socket for serial interface and supply (with accessory: USB adapter USB 5100)

Display:

4 ½ digit 7-segment, illuminated (white)

Housing:

Protection class:	IP65 / IP67
Dimensions:	160 x 86 x 37 mm (H x B x T) incl. silicone protection cover
Weight:	approx. 250 g incl. battery and protection cover

Power supply:

2x AAA battery (included)



depends on cell constant of used electrode

* cell constant 0.01 / cm

** cell constant 0.1 ... 1.2 / cm

Handheld device for conductivity measurement

GMH 5430 without electrode

Available from the 2nd quarter of 2012

GMH 5450 analog output and data logger, without electrode





Available from the 2nd quarter of 2012

NEW



Functions	GMH 5430	GMH 5450
Min / max value memory	x	x
Hold / auto-hold	x	x
Auto power off	x	x
Low battery display "BAT"	x	x
Display of condition of battery	x	x
Background lightning	x	x
Period selectable (on/off or 5 s ... 2 min)		
Adjustment	Cell constant manually or automatically by selectable reference solution Option: multi-point adjustment	
	-	Separate cell constants for conductivity measuring ranges
GLP (Good Laboratory Practice)	adjustable calibration intervals	adjustable calibration intervals Calibration memory: latest 16 calibrations
Real-time clock	x	x
Analog output	-	0 - 1 V, freely adjustable, connection with 4-pole bayonet connector, Resolution 13 bit, accuracy 0.05% at nominal temp.
Data logger	-	cyclic: 10.000 data sets Single value: 1.000 data sets (with measuring point input, 40 adjustable measuring point texts or measuring point numbers)
Min-/max-alarm	-	Permanent monitoring of alarm boundaries for conductivity and temperature: 3 alarm conditions - off: Alarm function inactive - on: Alarm report via display, integrated buzzer and interface - no Sound: Alarm report only via display and interface

Electrodes

	Type	Measuring range	Cell constant	Temperature measurement	Dimensions	Characteristics	Applications	Price
	LF 200 RW	0 ... 100 µS/cm	0.1	NTC 10k	Ø 12 mm	2-pole stainless steel	Pure and ultra pure water	
	LF 210	0 ... 1000 µS/cm	1	NTC 10k	Ø 12 mm	2-pole glass/platinum	Alcohol, fuel, diesel	
	LF 202	0 ... 20 mS/cm	1	NTC 10k	Ø 12 mm	2-pole graphite	Universal application	
	LF 400	0 ... 200 mS/cm	0.55	NTC 10k	Ø 12 mm	4-pole graphite	Universal application	
	LFE 425	0 ... 1000 mS/cm	upon request	Pt 1000	Ø 16 mm	4-pole graphite	Robust and precise for highest demands	

General function description

Min / Max Value Memory: highest and lowest measured value is saved

Auto-Hold: automatic freezing of a constant measuring value

Auto Power Off: device is automatically switched off after a selected period if unused (0 to 120 min, or deactivated)

Additional Display for Battery and Low Battery Display "BAT"

Automatic temperature compensation: As conductivity depends strongly on temperature, each conductivity value is only valid at the corresponding temperature. Therefore the device supports temperature compensation, i.e. referring the conductivity to a reference temperature (selectable: 20 °C or 25 °C).

Salinity measurement: Salinity means the sum of the concentrations of all dissolved salts in water. The unit is g/kg.

TDS measurement (total dissolved solids): TDS means the mass concentration of dissolved media in a liquid. The unit is mg/l.

Accessories

EBS 20M software for long-term monitoring (p.r.t. page 58)

GSOFT 3050 (p.r.t. page 58)
Software for operation of logger devices

USB 5100
Electrically isolated interface converter, supplied via USB

GKK 3500 (p.r.t. page 56)
Device case with eggcrate foam and cut-outs for 1 device (394 x 294 x 106 mm)

GEH 1 (p.r.t. page 56)
Electrode holder for measuring electrodes with plastic handle

Conductivity measuring devices



- Wide measuring range from 0,0 $\mu\text{S}/\text{cm}$ to 200,0 mS/cm manually selectable or automatic range selection
- Double display for conductivity and temperature
- Display of resistance, salinity or TDS (dry residue of filtrate)
- Conform to the regulations of the drinking water ordinance (TrinkwV 2001) and DIN EN 27888
- Automatic temperature compensation, reference temp. ($20^\circ\text{C}/25^\circ\text{C}$) selectable
- Setting of different temperature coefficients
- Extremely small measuring probe (dimensions as for pH-probe)
- Min./Max. value memory, Hold function,
- Serial interface, device can be connected to bus system (up to 5 devices can be connected to one PC interface)
- Battery and d.c. operation

GMH 3430

Conductivity measuring device incl. probe

Specification:

Measuring range:

Conductivity: 0,0 ... 200,0 $\mu\text{S}/\text{cm}$
 0 ... 2000 $\mu\text{S}/\text{cm}$
 0,00 ... 20,00 mS/cm
 0,0 ... 200,0 mS/cm
manual setting or auto range

Temperature: $-5,0 \dots +100,0^\circ\text{C}$

Resistance: 0,005 ... 100,0 $\text{k}\Omega \cdot \text{cm}$

Salinity: 0,0 ... 70,0

TDS: 0 ... 1999 mg/l

Resolution: 0,1 $\mu\text{S}/\text{cm}$; 1 $\mu\text{S}/\text{cm}$; 10 $\mu\text{S}/\text{cm}$ or 0,1 mS/cm
 0,1 $^\circ\text{C}$
 0,001 $\text{k}\Omega$; 0,01 $\text{k}\Omega$ or 0,1 $\text{k}\Omega$
 0,1 (salinity)
 1 mg/l

Accuracy: (± 1 digit) (at nominal temperature = 25°C)

Conductivity: $\pm 0,5\%$ of m.v. $\pm 0,3\%$ FS or $\pm 2\mu\text{S}/\text{cm}$

Temperature: $\pm 0,2\%$ of m.v. $\pm 0,3\text{K}$

Cell constant: adjustable from 0.800 ... 1.200 cm^{-1}

Temp. compensation: automatic or off

Compensation coefficient:

- nLF: non-linear function of natural water according to EN27888 (DIN38404) (reference temperature adjustable 20°C or 25°C)
- Lin: linear compensation from 0,3 ... 3,0 $\%/K$ (reference temperature adjustable 20°C or 25°C)
- off: no compensation

Display: 2 four digit LCDs (12.4mm and 7mm high) for conductivity (resistance, salinity, TDS) and temperature, min./ max values, hold function, etc. as well as additional functional arrows.

Measuring cell: 2-pol conductivity measuring cell; temperature sensor integrated in shaft. Electrode material: graphite. The graphite electrodes are the optimum solution for sewage and can be cleaned easily.

Warranty for sensor element: 12 months

Working temperature: 0 to $+50^\circ\text{C}$ (device)
 meas. cell: 0 to $+80^\circ\text{C}$ (permanent) 0 to $+100^\circ\text{C}$ (short time)

Relative humidity: 0 to $+95\%$ RH (non-condensing)

Min/Max-value memory: max. and min. values as well as the corresponding temperature will be memorized.

Hold function: the current meas. value will be 'frozen'.

Interface: serial interface, direct connection to RS232 or USB interface of a PC via electrically isolated interface converter GRS3100 or GRS3105 resp. USB3100 (p.r.t. accessories).

Pushbuttons: 6 membrane keys for ON/OFF-switch, selection of meas. range, min- and max-value memory, hold-function, etc.

Power supply: 9V-battery, type IEC 6F22 (included) as well as additional d.c. connector (internal pin $\varnothing 1.9\text{mm}$) for external 10.5-12V direct voltage supply. (suitable power supply: GNG10/3000)

Power-Off-function: Device will be automatically switched off if no key is pressed/no interface communication takes place for the time of the power-off delay. The power-off delay can be set to values between 1 and 120 min.; it can be completely deactivated.

Low battery warning: Δ and 'bAt'

Power consumption: approx. 3.5 mA (meas. power not incl.)

Housing dimensions (device): 142 x 71 x 26 mm (H x W x D)
 Impact-resistant ABS plastic housing, membrane keyboard, transparent panel. Front side IP65, integrated pop-up clip for table top or suspended use.

Electrode dim.: approx. 120mm long, \varnothing approx. 12mm, 1m of fixed connection cable between electrode and device.

Weight: approx. 255 g (incl. batteries and measuring cell)

Automatic temperature compensation: The conductivity is highly dependant on the temperature, i.e. it is only valid for one temperature. For better comparison the device offers the possibility to compensate the conductivity to a reference temperature (adjustable 20°C or 25°C).

Temperature measurement: The temperature of the agent can be displayed by means of the temperature probe integrated in the electrode.

AutoRange: Automatic selection of to the optimum meas. range for conductivity measurements. AutoRange mode can be deactivated by pressing a button.

Salinity determination: Salinity is understood to be the sum of concentrations of all salts dissolved in water. Reading in g/kg.

TDS-determination (dry residue of filtrate): The dry residue of filtrate is understood to be the concentration of substances dissolved in a liquid. Reading in mg/l .

Option:

- LTG

for organic matter (alcohol, petrol, diesel)
 up to max. 1000 $\mu\text{S}/\text{cm}$

with glass shaft, unplatinized,
 1,35 m PUR-cable, fix connected with device



Accessories:

GKL 100 100ml conductivity control solution (100ml bottles with 1413 $\mu\text{S}/\text{cm}$. (pursuant to DIN EN 27888))

miscellaneous accessories (case, power supply, etc.)
 suitable for all GMH3xxx devices p.r.t.p. 56 - 58

pH / Redox handheld instruments



Application:	Device	GMH 5530	GMH 5550	GMH 3530	GPH 014	GPRT 1400 AN
Waters measuring, fish-keeping, aquafarming		✓	✓	✓	✓	✓
Drinking water-, process monitoring, ground measurements		✓	✓	✓	✓	✓
Food production and -control		✓	✓	✓	✓	✓
Precision measurement		✓	✓	✓		
Laboratory (GLP)		✓	✓			
Quality management		✓	✓	✓		✓
Data storage			✓			
Water-proof application		✓	✓			

Function / Equipment:	Device	GMH 5530	GMH 5550	GMH 3530	GPH 014	GPRT 1400 AN
Specification						
Meas. range pH Redox / mV rH Temperature		-2,000..16,000 pH (selectable resolution) -2000,0..2000,0 mV (selectable resolution) 0,0..70,0 rH -5,0..150,0 °C		0,00..14,00 pH -1999..2000 mV 0,0..70,0 rH -100,0..+250,0 °C	0,00..14,00 pH -- -- --	0,00..14,00 pH -1999..1999 mV -- -20,0..+110,0 °C
Accuracy pH Redox / mV rH Temperature		±0,005 pH ±0,05 % FS (mV / mV _H) ±0,1 rH ±0,2 °C		±0,01 pH ±0,1 % FS (mV / mV _H) ±0,1 rH ±0,2 °C	±0,02 pH -- -- --	±0,02 pH ±0,2 % v. MW. ± 1 Digit -- ±0,5 °C ± 1 Digit
Connections pH / Redox Temperature		BNC-female connector 2 banana-jack		BNC-socket 4-pole Mini-DIN	CINCH-socket --	CINCH-socket 3,5 mm Ø jack connect.
Temperature-compensation		automatic and manual (Pt1000, NTC 10k)		automatic and manual (PT100)	manuel	automatic and manual
Functions						
General functions		Min/Max, Hold, Auto-Off, adjustable calibration intervals		Min/Max, Hold, Auto-Off		
Interface		✓	✓	✓		
Analog output			✓			✓
Calibration memory			✓			
Data logger, alarm			✓			
Catalog page		p. 32-33	p. 32-33	p. 34	p. 36	p. 36

Handheld instrument

Display / Controller

Logger / EASYBus

Transmitter

Temperature probe

Alarm / Protection

Waterproof handheld measuring device for pH / Redox

Features

- Waterproof (device and plug connections)
- Serial Interface and analog output
- Data logger- and alarm function
- GLP-features (Good Laboratory Practice)
- Robust silicone protection cover
- Big dual display
- Background lightning
- High resolution (0.001pH / 0.1 mV)

Field of application

- Waters measuring, fishkeeping, aquafarming
- Drinking water monitoring, process control, soil measuring
- Food production and monitoring
- Laboratory: Medicine, pharmaceuticals, chemistry
- Quality management



GMH 5530 without accessories

GMH 5550 with analog output and data logger, without accessories

Technical data

Measuring ranges:

pH:	-2.000 ... 16.000 pH
Redox / mV:	-2000.0 ... 2000.0 mV
Temperature:	-5.0 ... +150.0 °C
	23.0 ... 302.0 °F
rH:	0.0 ... 70.0 rH

Accuracy:

pH:	±0.005 pH
Redox / mV:	±0.05 % FS (mV or mV _H)
Temperature:	±0.2 °C
rH:	±0.1 rH

Connections:

pH, Redox: BNC-female connector, compatible to standard BNC-plugs and waterproof BNC-plugs, additional banana-jack (4 mm) for separate reference electrode
input resistance: 10¹² Ohm

Temperature: 2 banana-jacks (4 mm) for temperature probes (Pt1000 or NTC 10K)

Interface / Supply: 4-pole bayonet female connector for serial interface and supply (with accessory USB 5100)

Display:

two 4½ - digit seven-segment display (15 mm and 12 mm)

pH-Calibration

Automatically: 1-, 2- or 3- point calibration, GREISINGER-Standard-Buffer or Puffer to DIN19266 (A,C,D,F,G)

Manually: 1-, 2- or 3- point calibration

Protection class:

IP67 (Housing and connections)

Dimensions / Weight:

160 x 86 x 37 mm (H x W x D) incl. protection cover / 250 g incl. battery and protection cover

Housing:

impact resistant ABS housing with pop-up clip

Power supply:

2 x AAA-battery (incl. in scope of supply) power consumption: GMH 5530 <1.0 mA, GMH 5550 <2.0 mA

Battery life time:

GMH 5530: approx. 1000 hours, **GMH 5550** approx. 500 hours



Handheld measuring device for pH / Redox

GMH 5530 without electrode

GMH 5550 with analog output and data logger, without electrode

Functions	GMH 5530	GMH 5550
Min / max value memory	x	x
Hold / auto-hold	x	x
Auto power off	x	x
Low battery display "BAT"	x	x
Display of condition of pH-electrode	x	x
Background lightning	x	x
Period selectable (on/off or 5 s ... 2 min)		
Automatic temperature compensation	x	x
Adjustable calibration intervals (GLP)	x	x
Calibration memory (GLP)	-	x
Analog output	-	0 - 1 V, freely adjustable, connection with 4-pole bayonet connector, Resolution 13 bit, accuracy 0.05% at nominal temp.
Data logger	-	With measuring point input Recording interval: 1 s ... 1 h Recording period: 416 days at interval 1 h Value memory: cyclic: 10000 data sets; singular: 1000 data sets
Real-time clock	-	x
Min-/max-alarm	-	Permanent monitoring of alarm boundaries 3 alarm conditions - off: Alarm function inactive - on: Alarm report via display, integrated buzzer and interface - no Sound: Alarm report only via display and interface



General function description

Min / Max Value Memory: highest and lowest measured value is saved

Auto-Hold: automatic freezing of a constant measuring value

Auto Power Off: device is automatically switched off after a selected period if unused (0 to 120 min, or deactivated)

Additional Display for pH-Electrode and Battery: Bar graph display

Low Battery Display "BAT"

Automatic Temperature Compensation:

There is an automatic temperature compensation (ATC) in the range of 0-105 °C for operation mode "pH" and if a temperature probe is connected.

Without connected probe the temperature can be input manually.

pH-Calibration:

The used buffer is detected automatically. The temperature dependency of the buffer is automatically compensated.

Permissible electrodes' data: Asymmetry: ±55 mV / Slope: 45 ... 62 mV/pH

The condition of pH-Electrode is checked at each calibration.

1-, 2- or 3- point calibration with characteristics bend for GREISINGER-Standard-Buffer, buffer to DIN 19266 or manual buffer input

Redox-Measurement (ORP):

2 choices:

"mV" Standard-redox- or mV- measurement

"mVH" Conversion to hydrogen systems according to DIN38404 Teil 6

rH-Measurement

The rH-value is calculated from a measured Redox-value and a manually input pH-value.

Accessories

GE 125 waterproof pH-electrode with integrated Pt1000 temperature sensor incl. waterproof BNC-plug (p.r.t. page 35)

GE 117 (p.r.t. page 35)
pH-electrode with integrated Pt1000 temperature sensor

GTF 55 B

Pt1000 temperature immersion sensor for liquids
1 m PVC-cable with banana plugs

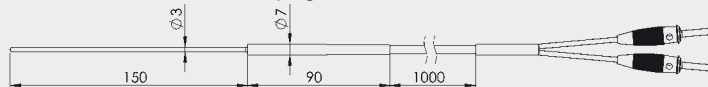

GE 100 BNC pH-electrode (p.r.t. page 35)

GE 105 BNC Redox-electrode (p.r.t. page 35)

GAK 1400 Working and calibration set (p.r.t. page 35)

PHL 4 pH buffer (pH 4,01 / 25 °C) 250 ml

PHL 7 pH buffer (pH 7,00 / 25 °C) 250 ml

PHL 10 pH buffer (pH 10,01 / 25 °C) 250 ml



GMH 55 ES

Supplementary set, including ph-electrode (GE 100 BNC), temperature probe (GTF 55 B), case (GKK 3500), working and calibration set (GAK 1400)

EBS 20M Software for long-term monitoring (p.r.t. page 58)

GSOFT 3050 (p.r.t. page 58)

Software for operation of logger devices

USB 5100

Electrically isolated interface converter with supply of device via USB

pH-/redox-/temperature measuring devices



- Double display for pH or redox and temperature
- Redox mode allows for automatic conversion to a hydrogen system.
- Automatic or manual temperature compensation
- Automatic buffer detection
- rH-measurements
- Evaluation of probe quality
- Battery and d.c. operation
- Serial interface, device can be connected to bus system (up to 5 devices can be connected to one PC interface)
- Device can be used as thermometer, too

GMH 3530 without accessories

GMH 35 ES additional set

pH-electrode GE100BNC, temperature probe GTF35 (Pt100 4-wire), case GKK3500 and GAK1400

Specification:

Measuring ranges:

Temperature: -100,0 ... +250,0°C
or -148,0 ... +482,0°F

pH: 0,00 ... 14,00 pH

Redox (ORP): -1999 ... +2000 mV.
for hydrogen system (DIN38404):
-1792 ... +2207 mV_H (at 25°C)

rH: 0,0 ... 70,0 rH

Accuracy: (device) ±1 digit at nominal temperature = 25°C

Temperature: ±0,2°C (-20...+80°C),
otherwise ±0.4°C

pH: ±0,01 pH

Redox (ORP): ±0,1% FS (mV or mV_H)

rH: ±0,1rH

Sensor connections:

Temperature: 4-pin screened Mini-DIN-socket.
for Pt100 4-wire (2-wire possible)

pH, Redox: BNC-socket

Input resistance: (pH, Redox) 10¹² Ohm

Display: 2 four digit LCDs
(12.4 mm or 7 mm high)

Working temperature: 0 to +50°C

Storage temperature: -20 to +70°C

Interface: serial interface, direct connection to RS232
or USB interface of a PC via electrically isolated interface
converter GRS3100 or GRS3105 resp. USB3100 (p.r.t.
accessories).

Power supply: 9V-battery, type IEC 6F22 (in-
cluded) as well as additional d.c. connector (internal
pin Ø 1.9mm) for external 10.5-12V direct voltage
supply. (suitable power supply: GNG10/3000)

Power consumption: approx. 3 mA

Housing dimensions (device): 142 x 71 x 26
mm (H x W x D), Impact-resistant ABS plastic
housing, membrane keyboard. Front side IP65, in-
tegrated pop-up clip for table top or suspended use.

Weight: approx. 165 g

Functions:

**Min/Max-value memory, Hold function, Auto-
Off-Function, Low battery warning**

Automatic temperature compensation: Au-
tomatic temp. comp. (ATC) if temperature probe
is plugged in and operating mode is "pH".
Temperatur compensation ragen: 0 - 105°C.
Manual temperature input if no probe connected.

pH-calibration: automatic buffer detection. Auto-
matic compensation of temperature dependance
of buffers.

acceptable electrode data:

Asymmetry: ±55 mV

Slope: 45...62 mV/pH

Sensor evaluation depending on calibration re-
sults (10 to 100%), displayed by pressing a key.

Opt. 2- or 3-point-calibration with bend of the
characteristics for GREISINGER-standard-buffer
(pH4.01, pH7.00, pH10.01), buffers acc. to
DIN19266 (A,C,D,F,G) or manual buffer entry.

Redox-Measurements(ORP):

you have 2 choices:

"mV" standard-redox- or mV-measurement

"mV_H" Temp. compensated conversion to
hydrogen system acc. to DIN38404 part 6, table
1 based on the standard redox electrode (e.g.
GE105 with Ag/AgCl system and 3mol KCl)
used.

rH-measurement: Calculation of the rH value
by means of a redox measuring and by manu-
ally entering the pH-value. The
pH-value can also be taken from a previous pH
measurement.

Temperature measurements: Display of current
value 12.4 mm high for thermometer mode.

Min-/Max- or Hold values can be displayed in the
second 7 mm high display.

Accessories:

GTF 35

temperature probe, Pt100 4-wire (p.r.t. page 101)

GE 100 BNC

Standard-electrode, BNC-plug

GE 109

pH electrode with integr. Pt100, without thread, BNC-
plug and MiniDIN-plug (suitable for GMH3530)

GNG 10/3000

plug-in power supply (recommend for logger application!)

GKK 3000

case with cut-outs for GMH3xxx

USB 3100 N

interface converter to USB, electrically isolated

EBS 20M

software for transmission, recording and archiving
measuring values obtained from 1 GMH3xxx (p.r.t. p. 41)

**miscellaneous accessories (case,
mains adaptors, etc.) p.r.t. p. 41 - 43**

pH-electrodes

for goods and food, etc.



	GE 101	GE 120
Measurand	pH	pH
Measuring range	2 - 11 pH 0 - 60 °C	0 - 14 pH 0 - 80 °C
Conductivity	> 200 µS	> 200 µS
Temperature meas.	no	no
Water proof	no	no
Pressure resistant	no	no
Cable	1 m	1 m
Electrolyte	3 mol/l KCL	3 mol/l KCL
Thread	without	without
Application	foods, suspensions, ground survey, etc.	frozen food, meat, cheeses, etc.
Connection	Cinch	Cinch
Price		

Options, upcharges:

- BNC

Electrode with BNC-plug

- Cable extension

(available cable length: 1, 2, 5 und 10 m)

- Special disign types

(electrodes with thread, other length, special
applications etc.)

Accessories:

VD120

injection aid for injection electrode GE101

GAD 1 CINCH

Adapter for the plug-in of electrodes with
Cinch-plugs to devices with BNC-sockets

GAD 1 BNC

Adapter for the plug-in of electrodes with
BNC-plugs to devices with Cinch-sockets.

GPF 100

Plastic bottle with wide neck, 100ml

**miscellaneous accessories
p.r.t. p. 35**

pH-electrodes, redox electrodes and accessories



	GE 014	GE 100	GE 106	GE 108	GE 151	GE 109	GE 117	GE 125	GE 105
Measurand	pH	pH	pH	pH	pH	pH	pH	pH	Redox
Measuring range	2 - 12 pH 0 - 60 °C	0 - 14 pH 0 - 80 °C	2 - 11 pH 10 - 80 °C	0 - 14 pH 0 - 80 °C	0 - 14 pH -5 - +80 °C	0 - 14 pH 0 - 80 °C	0 - 14 pH 0 - 80 °C	0 - 14 pH 0 - 70 °C	± 2000 mV 0 - 80 °C
Conductivity	> 200 µS	> 200 µS	> 25 µS	> 200 µS	> 200 µS	> 200 µS	> 200 µS	> 200 µS	> 25 µS
Temperature meas.	no	no	no	no	no	integrated Pt100	integrated Pt1000	integrated Pt1000	no
Water proof	no	no	no	no	no	no	no	yes	no
Pressure resistant	no	no	no	6 bar	no	6 bar	6 bar	1 bar	no
Cable	1 m	1 m	1 m	2 m	1 m	2 m	2 m	2 m	1 m
Electrolyte	3 mol/l KCL	3 mol/l KCL	3 mol/l KCL	Gel-Elektrolyt	3 mol/l KCL	Gel-Elektrolyt	Gel-Elektrolyt	Gel-Elektrolyt	3 mol/l KCL
Thread	without	without	without	PG13.5	without	without	PG13.5	without	without
Application	environmental analysis, swimming pool, aquarium, water treatment etc.	environmental analysis, swimming pool, aquarium, water treatment etc.	low-ionic media, VE-water, discus-fishes etc.	environmental analysis, swimming pool, aquarium, water treatment etc.	electroplating, partly for paints and varnishes, alkali resistant	environmental analysis, swimming pool, aquarium, water treatment etc.	environmental analysis, swimming pool, aquarium, water treatment etc.	environmental analysis, swimming pool, aquarium, water treatment, Food & Beverage	aquarium, ground survey, chemical analysis, sewage etc.
Connection	Cinch	Cinch	Cinch	Cinch	Cinch	BNC + Mini-DIN	BNC + 4mm Banane	BNC + 4mm Banane	Cinch
Price									

Note: elektrodes are consumption objects. Lifetime under careful treatment: > 2 Years / Warranty: 12 Month

Optionen, Aufpreise:

- **BNC:** Electrode with BNC-plug
- **Cable extension**
(available cable length: 1, 2, 5, other upon request)
- **Special design types**
(electrodes with thread, other length, special applications etc.)

Accessories:

- GPH 4,0 / 5** Buffer capsule (5 pcs), pH4.0
- GPH 4,0 / 10** Buffer capsule (10 pcs), pH4.0
- GPH 7,0 / 5** Buffer capsule (5 pcs), pH7.0
- GPH 7,0 / 10** Buffer capsule (10 pcs), pH7.0
- GPH 10,0 / 5** Buffer capsule (5 pcs), pH10.0
- GPH 10,0 / 10** Buffer capsule (10 pcs), pH10.0
- GPH 12,0 / 5** Buffer capsule (5 pcs), pH12.0
- GPH 12,0 / 10** Buffer capsule (10 pcs), pH12.0

All buffer salts are directly traceable to NIST standards and certified to ±0.02pH units at 25°C.

GAK 1400 Working and calibration set cons. of 5 buffer caps. each (GPH4,0, GPH7,0 und GPH10,0), 3 x GPF100, 1 x 3 mol KCl-electrolyte KCL3M and 1 x Pepsin-cleaning agent GRL100.

KCL 3 M 3 mol KCl-electrolyte for refilling and storage (fill into protective cap) of electrodes with 3 mol KCl electrolyte, injection bottle, 100 ml

CaCl 1000 ml
solution for measuring the pH-value of soil

GRL 100 Pepsin-cleaning agent, 100ml

GRP 100 Redox testing solution (220mV at 25°C), 100ml

GAD 1 CINCH Adapter for the plug-in of electrodes with Cinch-plugs to devices with BNC-sockets.

GAD 1 BNC Adapter for the plug-in of electrodes with BNC-plugs to devices with Cinch-sockets.

GWA1Z thread adapter PG13.5 to G1", plastics

PG 13.5 plug on thread adapter
for pressureless use, for any electrode

miscellaneous accessories
p.r.t. p. 34



digital pH-Meter

GPH 014

Device ready for use incl. pH-electrode type GE 014 and battery. (no buffer solutions)

Specification:

Measuring range (device):	0.00 up to 14.00 pH
Resolution:	0.01 pH
Accuracy	(device) at nominal temperature = 25°C: +/-0.02 pH +/- 1 digit
Input resistance:	10 ¹² Ohm
pH-electrode:	combined measuring and reference electrode type GE 014 with refillable 3 mol-KCl electrolyte, 2-12 pH, 0 to 60° C
Calibration:	3 turning knobs for: - temperature compensation 0 to 90° C - pH7 value - pH x-value (eg 4.0/10.0/12.0)
Working temperature:	0 to 45° C
Display:	3½-digit LCD display, 13mm high
Power supply:	9V battery type JEC 6F22 (incl.)
Low battery warning:	automatic; "BAT" displayed in case of low voltage
Battery service life:	approx. 200 operating h
Dimensions:	approx. 106 x 67 x 30 mm (H x W x D). Impact resistant ABS housing.
Weight:	approx. 200 g (incl. battery and electrode)

GAK 1400

Working and calibration set:

Working and calibration set consisting of 5 buffer capsules each **GPH4.0**, **GPH7.0** and **GPH10.0**, 3 x 100ml-plastic bottle **GPF100**, 1 x 3 mol KCL-electrolyte **KCL3M** and 1 x Pepsin-cleaning agent **GRL100**.
GAK1400 is required if no buffer solutions are existing at your works.

Accessories:

GE 014	Spare electrode
GPH 014 GL	Loose device (without accessories)
GE 100	Better electrode (0-14pH, 0-80°C)
GE 101	Injection electrode (2-11pH, 0-60°C)
GE 106	pH-electrode for low-ion water (as of 25 µS/cm)
GKK 252	Case (235 x 185 x 48 mm) with foam lining
GKK 1100	Case (340 x 275 x 83 mm) with foam lining
GB 9 V	Spare battery

for add. accessories p.r.t. p. 35, 56 - 58

automatic temperature compensation



digital pH- / mV- / Thermometer

GPRT 1400 AN

Device ready for use incl. pH-electrode GE100, buffer capsules pH4 and pH7, two 100ml-plastic bottles as well as temperature probe.

Battery/mains operation, analog output: 1mV/digit, ATC = Automatic Temperature-Compensation.

Specification:

Measuring range:	
Position 1 (pH):	0,00 ... 14,00 pH
Position 2 (°C):	-20,0 ... +110,0 °C
Position 3 (mV):	-1999 ... +1999 mV
Resolution:	0,01pH, 0,1°C or 1mV
Accuracy (device):	(at nominal temperature = 25°C)
(pH):	± 0,02 pH ± 1 digit
(°C):	± 0,5 °C ± 1 digit (range: -10 to 110°C)
(mV):	± 0,2 % of m.v. ± 1 digit
Input resistance:	10 ¹² Ohm
pH-electrode:	combined measuring and reference electrode type GE 100 with refillable 3 mol-KCl electrolyte 0-14pH, 0-80°C
Attention!	<i>The pH-electrode does not allow for redox-measurements! Please order redox electrode GE105 separately, if required (p.r.t. p. 35)</i>
Temperature probe:	silicon temperature probe, electr. insulated in V4A-pipe, 6mm Ø, approx. 100mm length, approx. 1m silicone cable with 3.5mm Ø jack connector for connection to front-side socket.

Instrument is calibrated to included probe. If probe is replaced a new calibration is necessary.

Calibration:	3 turning knobs for - temperature compensation 0-90°C (automatically when probe is plugged in) - pH7-value - pHX-value (eg. 4.0, 10.0, 12.0)
Working temperature:	0 to 45° C
Display:	3½-digit LCD display, 13mm high
Analog output:	1mV / digit, connection via 3.5 mm Ø jack connector (jack connector included)
Power supply:	9V-battery type IEC 6F22 (incl.). Additional power supply connector socket 2,5mm Ø.
Low battery warning:	automatic; "BAT" displayed in case of low voltage.
Battery service life:	approx. 100 operating h
Dimensions:	approx. 150 x 86 x 30 mm (H x W x D). Impact resistant ABS housing with integrated pop-up clip for table top or suspended use, electrode clipped on at the side
Weight:	approx. 330 g (ready for use)

Accessories:

GPRT 1400 AN GL	loose device
GTF 1400 B	spare temperature probe

for add. accessories p.r.t. p. 35, 56 - 58

Pressure handheld instruments



Application:	Device	GMH 5130 GMH 5150 GMH 5155	GMH 3111 GMH 3151 GMH 3156	GMH 3161-12 GMH 3181-12	GMH 3161-01 GMH 3161-07... GMH 3161-13	GMH 3181-01 GMH 3181-07 GMH 3181-13	GDH 200-07 GDH 200-13	GDH 200-14	GPB 3300 GTD 1100	GDH xx AN GDH 12 AN
Relative pressure meas. (over, under- and pressure difference)		✓ ✓ ✓	✓ ✓ ✓		✓ ✓ ✓	✓ ✓ ✓	✓ ✓			✓
Absolute pressure meas.		✓ ✓ ✓	✓ ✓ ✓	✓ ✓				✓	✓ ✓	✓
Heating, ventilation, climate		✓ ✓ ✓	✓ ✓ ✓	✓ ✓	✓ ✓ ✓	✓ ✓ ✓	✓ ✓	✓	✓ ✓	✓
Meas. in liquids		✓ ✓ ✓	✓ ✓ ✓							
Vacuum meas.		✓ ✓ ✓	✓ ✓ ✓	✓ ✓				✓		✓
Meteorology				✓ ✓				✓	✓	✓
Altitude measuring (sports)									✓	
Water-proof application		✓ ✓ ✓								
Optionally EX-protection			✓ ✓ ✓	✓ ✓	✓ ✓ ✓	✓ ✓ ✓				

Function / Equipment:	Device	GMH 5130 GMH 5150 GMH 5155	GMH 3111 GMH 3151 GMH 3156	GMH 3161-12 GMH 3181-12	GMH 3161-01 GMH 3161-07... GMH 3161-13	GMH 3181-01 GMH 3181-07 GMH 3181-13	GDH 200-07 GDH 200-13	GDH 200-14	GPB 3300 GTD 1100	GDH xx AN GDH 12 AN
Specification										
Plug-in probe		1 1 2	1 1 2							
Meas. range pressure (max.) [mbar]		depends on sensor	depends on sensor	0..1300	..-01: -1..25 ..-07: -10..350 ..-13: -100..2000		..-07: 0..200 ..-13: 0..2000	0..11000	300..1100	..01: 0..20 ..07: 0..200 ..12: 0..1300 ..13: 0..2000 ..14: 0..11000
Additional measurands									GTD 1100: -10..+50 °C -500..+9000 m	
Units		mbar, bar, Pa, kPa, MPa, mmHg, PSI, mH ₂ O					mbar (hPa), mmHg, PSI ..-07: zus. Pa	mbar (hPa), mmHg, PSI	mbar (hPa), mmHg	mbar (hPa)
Functions:										
Min/Max, Zero, Auto-Off		✓ ✓ ✓	✓ ✓ ✓	✓ ✓	✓ ✓ ✓	✓ ✓ ✓	✓ ✓	✓	✓ ✓	
Alarm		✓ ✓	✓ ✓	✓		✓ ✓ ✓				
Data logger		✓ ✓	✓ ✓	✓		✓ ✓ ✓				
Interface		✓ ✓ ✓	✓ ✓ ✓	✓ ✓	✓ ✓ ✓	✓ ✓ ✓				
Analog output		✓ ✓	✓ ✓	✓		✓ ✓ ✓				✓ ✓
Catalog page		p. 38-39	p. 40-41	p. 44	p. 45	p. 45	p. 46	p. 46	p. 47	p. 48

Water-proof handheld device for pressure measurement with external changeable probes

Features

- Water-proof (device and plug-in connections)
- Serial interface and analog output
- Data logger and alarm function
- Peak value detection (1000 measurements / s)
- Leakage test
- Robust silicone protection cover
- Large double display
- Background illumination

Application

Mobile use for:



- industry and craft
- HVAC: heating, ventilation, air-conditioning
- leakage test / pressure test
- chimney draft measurement: under pressure
- leakage test at buildings (i.e. 4 Pascal test)
- measurements of gas and oil firings
- automobile trade



GMH 5130 with 1 sensor connections, without sensor

GMH 5150 with 1 sensor connections, analog output and data logger, without sensor

GMH 5155 with 2 sensor connections, analog output and data logger, without sensors

Specification	GMH 5130	GMH 5150	GMH 5155
Sensor connections:	1	1	2
Connections:			
Sensor	1x 7-pole bayonet socket	1x 7-pole bayonet socket	2x 7-pole bayonet socket
Output / ext. supply	4-pole socket for serial interface and supply (with accessories: USB adapter USB 5100)	4-pole socket for serial interface and supply (with accessories: USB adapter USB 5100)	4-pole socket for serial interface and supply (with accessories: USB adapter USB 5100)
	--	analog output 0 ... 1 V	analog output 0 ... 1 V
			
Suitable probes:	GMSD / MSD sensors, available ranges (resolutions): from -1.999 ... 2.500 mbar / (0.001 mbar) till 0 ... 1000 bar (1 bar)		
Display unit:	depends on measuring range selection and sensor: mbar, bar, Pa, kPa, MPa, mmHg, inHg, PSI, mH ₂ O		
Measuring frequency:	4 measurements / s or 1000 measurements / s		
Accuracy:	± 0.1 % FS ± 1 digit		
Display:	4 ½ digit 7-segment, illuminated (white)		
Adjustment:	offset / slope via menu		
Housing:			
Protection class:	IP65 / IP67		
Dimensions:	160 x 86 x 37 mm (H x W x D) incl. silicone protection cover (red)		
Weight:	ca. 250 g incl. battery and protection cover		
Power supply:	2x AAA battery (included)		

Handheld device for pressure measurement

GMH 5130 with 1 sensor connections, without sensor

NEW

GMH 5150 with 1 sensor connections, analog output and data logger, without sensor

GMH 5155 with 2 sensor connections, analog output and data logger, without sensors

Functions	GMH 5130	GMH 5150	GMH 5155
Min / max value memory	x	x	x
Hold / auto-hold	x	x	x
Auto power off	x	x	x
Low battery display "BAT"	x	x	x
Display of condition of battery	x	x	x
Background lightning	x	x	x
Period selectable (on/off or 5 s ... 2 min)			
User-defined unit	-	conversion to arbitrary unit by linear factor	
Average filter	adjustable: 1 ... 120 s	adjustable: 1 ... 120 s	adjustable: 1 ... 120 s
Leakage test function	-	leak rate display, leak rate alarm (/s, /min, /h)	
Air velocity / flow volume	-	Pitot tube measurement (accessories)	
Analog output	-	0 - 1 V, freely adjustable, connection with 4-pole bayonet connector, Resolution 12 bit	
Data logger	-	cyclic: 10.000 data sets	cyclic: 8.000 data sets
		Single value: 1.000 data sets (with measuring point input, 40 adjustable measuring point texts or measuring point numbers)	
Min-/max- alarm	-	channels: 1	channels: 3 (sensor 1, sensor 2, difference) with individual alarm boundaries
		Permanent monitoring of alarm boundaries 3 alarm conditions - off: Alarm function inactive - on: Alarm report via display, integrated buzzer and interface - no Sound: Alarm report only via display and interface	



General function description

Min / Max Value Memory: highest and lowest measured value is saved

Auto-Hold: automatic freezing of a constant measuring value

Auto Power Off: device is automatically switched off after a selected period if unused (0 to 120 min, or deactivated)

Additional Display for pH-Electrode and Battery: Bar graph display

Low Battery Display "BAT"

Note to pressure unit selection:

A pressure unit can be selected only if the whole measuring range of this unit can also be displayed and the sensor supports the corresponding resolution.

Accessories



GMSD ... K51 pressure sensors (p.r.t. page 42)

Application field: non-aggressive gases for over / under pressure and difference pressure measurements or absolute pressure measurements



MSD pressure sensors / stainless steel (p.r.t. page 43)

Application field: air, aggressive gases for over / under pressure and difference pressure measurements or absolute pressure measurements

MSD-K51 1 m connection cable for MSD sensors

EBS 20M software for long-term monitoring (p.r.t. page 58)

GSOFT 3050 (p.r.t. page 58)

Software for operation of logger devices

USB 5100

Electrically isolated interface converter, supplied via USB

Prandtl-Staurohr (made of stainless steel)

for air velocity / flow volume measurement
Ø = 3 mm, NL = 300 mm, max. 600 °C

GKK 3500

Device case with eggcrate foam and cut-outs for 1 device
(394 x 294 x 106 mm)

Hand-held pressure measuring device

GMH 3111

- ▶ **one** device for any measuring range (2.5 mbar ... 1000 bar)
- ▶ **calibrated and fully interchangeable pressure probes**
- ▶ **tara, hold function, min-/max-value memory, ready for bus operation**



Probes for following pressure ranges are available:

- relative pressure 2,50 mbar ... 1000 bar rel.
- pressure difference 0,00 bar ... 10,00 bar
- absolute pressure 0,00 bar ... 35,00 bar
- special measuring ranges upon request

GMH 3111 (probes not included)

GMH 3111 - ex ( device without probe)

*suitable
pressure probes
page 42 / 43*

Specification:	GMH 3111	GMH 3111-ex
max. display range:	-19999 ... +9999 Digit	-19999 ... +19999 Digit
Measuring range:	corresponding to used probe	
Overload:	corresponding to used probe	
Resolution:	corresponding to used probe	
Accuracy: (device)	±0,1%FS ±1Digit (at nominal temperature = 25°C)	
Pressure units:	mbar, bar, Pa, kPa, MPa, mmHg, PSI, mH ₂ O, can be selected.	
Probe connection:	1 sensor socket	1 sensor socket 6-pin screened lockable Mini-DIN-socket(s) for GMSD/MSD-sensors. Automatic probe detection and setting of meas. range upon plugging in of probe.
Display:	2 x 4½-digit LCD	2 x 4½-digit LCD
Output:	serial interface	serial interface
- serial interface:	direct connection to RS232 or USB interface of a PC via interface converter GRS3100, GRS3105 or USB3100 (accessories).	
- analog output:	--	--
Power supply:	9V-battery, d.c. connector	9V-battery, d.c. connector <i>suitable 9V-battery (type IEC 6F22) in scope of supply, d.c. connector for external 10.5-12V direct voltage supply. (suitable power supply: GNG10/3000)</i>
Sensor adjustment:	digital offset and scale input	digital offset and scale input
Tare, hold, min/max value:	X	X
Peak value memory:	--	--
Measuring cycle:	4 measurements / s	4 measurements / s
Logger functions:	--	--
Averaging function:	--	--
Min-/max-alarm:	--	--
Power consumption:	approx. 1,6 mA (incl. sensor)	max. 1,6 mA (incl. sensor)
Working condition:	-25 ... 50°C, 0 ... 95%RH	-10 ... 50°C, 0 ... 95%RH
Power-Off-function:	1...120 min (can also be deactivated).	
Housing dimensions:	142 x 71 x 26 mm, impact-resistant ABS plastic housing, Front side IP65 integrated pop-up clip for table top or suspended use.	Front side IP65
Weight:	approx. 150 g	approx. 190 g (incl. case)

Note to Ex- design types:

Technical changes compared to standard instrument (valid for all GMH31xx - ex)

Ex qualification:  II 2 G Ex ib IIC T4

Ref. document: EPS 09 ATEX 1 227 X

Standards: The device meets the standards for electric resources in explosion endangered areas according to EN 60079-0 : 2006, EN 60079-11 : 2007

Probe: (GMH 3111 - ex, GMH 3151 - ex, GMH 3156 - ex)
All GMSD sensors with option 'Ex type' can be used.

Interface: suitable interface adapter are USB 3100 N, GRS3100 and GRS3105

Please note: the operation of the interface is not allowed within the Ex area!

Working temperature: -10 to +50°C

Power supply: 9V-battery, d.c. connector

Please note: the use of d.c. connector is not allowed within the Ex area! Just d.c. connectors of type GNG10/3000 can be used.

Alarm function: (GMH 3151 - ex, GMH 3156 - ex, GMH 3181 - ex)
The device is without a horn, in the alarm settings are only the parameter "no.so" and "off" adjustable.

Scope of supply: device with associated leather case.

Note to the pressure unit selection:

(information for all GMH31xx)

The choice of a specific pressure unit is possible, if its whole measuring range is displayable within the display of the device and the sensor is support these resolution.

Pressure measuring device with logger

GMH 3151



Special features:

- 4½-digit display probes with higher resolution up on request
- logger functions
- peak value memory
- analog output 0-1V
- 1000 measurements / second
- digital sensor adjustment possible
- min- / max-alarm
- integrated horn

Additional function of the GMH3156:

- 2 GMSD/MSD-probes connectable
- difference measurement of two probes

GMH 3156



suitable
pressure probes
page 42 / 43

GMH 3151 (probe not included)

GMH 3156 (probes not included)

GMH 3150 - ex (Ex device without probe)

GMH 3156 - ex (Ex device without probes)

Specification:	GMH3151	GMH3156	GMH3151-ex	GMH3156-ex
max. display range:	-19999 ... +9999 digit		-19999 ... +19999 digit	
Measuring range:	corresponding to used probe		corresponding to used probe	
Overload:	corresponding to used probe		corresponding to used probe	
Resolution:	corresponding to used probe		corresponding to used probe	
Accuracy: (device)	±0,1%FS ±1Digit (at nominal temperature = 25°C)			
Pressure units:	mbar, bar, Pa, kPa, MPa, mmHg, PSI, mHzO, can be selected.			
Probe connection:	1	2	1	2
	6-pin screened lockable Mini-DIN-socket(s) for GMSD/MSD-sensors. Automatic probe detection and setting of meas. range upon plugging in of probe.			
Display:	2 x 4½-digit LCD		2 x 4½-digit LCD	
Output:	serial interface o. AAG		serial interface o. AAG*	
- serial interface:	direct connection to RS232 or USB interface of a PC via interface converter GRS3100, GRS3105 or USB3100 (accessories)		direct connection to RS232 or USB interface of a PC via interface converter GRS3100, GRS3105 or USB3100 (accessories)	
- analog output:	0-1V, freely adjustable (res. 12bit)		0-1V, freely adjustable (res. 12bit)	
Power supply:	9V-battery, d.c. connector suitable 9V-battery (type IEC 6F22) in scope of supply, d.c. connector for external 10.5-12V direct voltage supply. (suitable power supply: GNG10/3000)		9V-battery, d.c. connector*	
Sensor adjustment:	digital offset and scale input		digital offset and scale input	
Tare, hold, min/max value:	X	X	X	X
Peak value memory:	≥1 ms		≥1 ms	
Measuring cycle: "slow"	4 measurements / s		4 measurements / s	
"fast" (with filter)	≥ 1000 meas. / s		1000 meas. / s	
"peak-detect"	≥ 1000 meas. / s		1000 meas. / s	
Logger functions:				
manually data sets:	99		99	
-cycle data sets:	10000	4000	10000	4000
	(max. 64 recording sequences)		(max. 64 recording sequences)	
-adjustable cycle time:	1 ... 3600 seconds		1 ... 3600 seconds	
Averaging function:	X	X	X	X
Min-/max- alarm:	X	X	X*	X*
Real-time clock:	X	X	X	X
Power consumption:	max. 1.6mA (slow mode) max. 7mA (fast = 1000Hz)		max. 1.6mA (slow mode) max. 7mA (fast = 1000Hz)	
Working condition:	-25 to +50°C, 0 to +95%r.F. (non-condensing)		-10 ... 50°C, 0 ... 95 %RH (non-condensing)	
Power-Off-function:	1...120 min (can also be deactivated).			
Housing dimensions:	142 x 71 x 26 mm, impact-resistant ABS plastic housing. Front side IP65			
Weight:	approx. 150 g		approx. 190 g (incl. case)	

* refer to note to EX-design types at page 40

General functional description:

- Tare function:** display value and the min./max values memorized can be set to zero.
- Hold function:** by pressing a button the current meas. value will be memorized.
- Min./Max. value memory:** memorizing of max. and min. values.
- Peak value memory (peak-detect):** In the min-/max-value memory will be detected not filtered pressure peaks ≥1msec.
- Averaging function:** integrates the meas. values during a selectable period of time and then calculates the average display value.
- Logger operation:** Logger start and stop via the keyboard or interface. Comfortable read-out and display software (GSOFT3050) available as additional equipment.
- Low power logger mode:** (only in meas. cycle "slow") Only one measurement carried out at the end of the respective logger cycle. The battery life is considerably prolonged. For long-term recordings (eg. tightness).
- Min-/Max-alarm:** the measuring value is constantly monitored if they remain within the min./max. limits set (deaktivatable)
- Alarm:** 3 different alarm settings
- "off" - alarm function deactivated
 - "on" - visual alarm via display, interface alarm, alarm sounded via integrated horn.
 - "no.So." - visual alarm via display and interface alarm
- Controlling function:** with the help of the switching module GAM3000 (optionally) electric equipment can be switched on/off or alarm memoried (see accessories)
- SeaLevel-correction:** when connecting an abs. pressure probe the barom. air press. can also be displayed corrected to sea level "zero". (Air pressure comp. achieved by entering the meters above sea level "zero")



Pressure sensors:

for use with GMH31xx, GDUSB (Type GMSD ...), GMH 51xx (Type: GMSD ... - K51)

- Application:
- air and non aggressive gases
 - sensor are not suitable for water / liquids

Relative pressure sensors: for measuring of over / under pressure and pressure difference

	GMSD 2,5 MR ..	GMSD 25 MR ..	GMSD 350 MR ..	GMSD 2 BR ..	GMSD 10 BR ..
Measuring range	-1,999...+2,500 mbar	-19,99...+25,00 mbar	-199,9...+350,0 mbar	-1000...+2000 mbar	-1.00... 10.00 bar
Overload	max. 200 mbar	max. 300 mbar	max. 1 bar	max. 4 bar	max. 10.34 bar
Resolution	0,001 mbar (0,1 Pa)	0,01 mbar (1 Pa)	0,1 mbar	1 mbar	10 mbar
Accuracy (typ.)					
hysteresis and linearity	± 0,2 % FS	± 0,2 % FS	± 0,2 % FS	± 0,2 % FS	± 0,2 % FS
temperature influence from 0-50°C	± 1,0 % FS	± 0,5 % FS	± 0,4 % FS	± 0,4 % FS	± 0,4 % FS
Prices					
GMSD ...					
GMSD ... - K51					

Absolute pressure sensors: for measuring of absolute pressure

	GMSD 1,3 BA ..	GMSD 2 BA ..	GMSD 7 BA ..
Measuring range	0 ... 1300 mbar abs.	0 ... 2000 mbar abs.	0.00 ... 7,00 bar abs.
Overload	max. 4 bar abs.	max. 4 bar abs.	max. 10,34 bar abs.
Resolution	1 mbar	1 mbar	10 mbar
Accuracy (typ.)			
hysteresis and linearity	± 0,2 % FS	± 0,2 % FS	± 0,2 % FS
temperature influence from 0-50°C	± 0,4 % FS	± 0,4 % FS	± 0,4 % FS
Prices			
GMSD ...			
GMSD ... - K51 *			

General Specification:

- Sensor:** piezoresistive pressure sensor
- Pressure connection:** 2 connection pins for tubes 6 x 1 mm (6mm inside-Ø and 4mm outside-Ø)
- Electronics:** PC board with amplifier and data memory for sensor data (measuring. range/calibration etc.) integrated in sensor housing.
- Working temperature:** 0 ... +70 °C
- Relative humidity:** 0 ... +95 % r.F. (nicht betauend)
- Storage temperature:** -40 ... +85 °C
- Housing:** ABS plastic with suspension eye, dimensions do not incl. conn. pin: 68 x 32,5 x 15 mm, dimensions with connection pin: 68 x 32,5 x 27,5 mm.
- Weight:** approx. 75 g

Device connection:

- GMSD ... :** 1m PVC connection cable, screened with integral 6-pin Mini-DIN-plug, lockable
- GMSD ... - K51:** 1m PVC connection cable, screened with 7-pin bayonet plug

Options, upcharges:

Probes for Ex-protection

Higher probe accuracy by multi point calibration
Additional individual linearisation points are stored in sensor memory. (not possible for GMSD 2,5 MR and GMSD 25 MR !)

Certificate of calibration WPD5

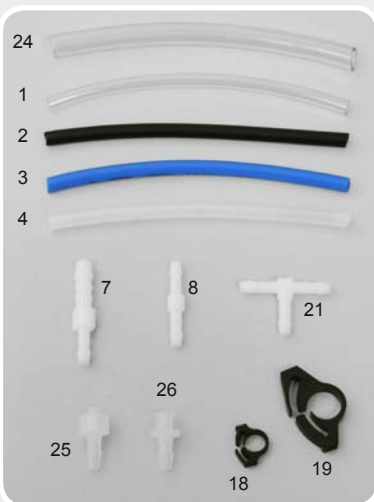

TUBE, TUBE CLIPS, ADAPTER, COUPLINGS, etc.

for GMH31xx, GMSD, GDH and pressure measuring transducers.

- GDZ-01** = PVC-tube 6/4 (6 mm outside-Ø, 4 mm inside-Ø) (5 bar @ 23°C)
- GDZ-24** = PVC-tube 10/7 (10 mm outside-Ø, 7 mm inside-Ø) (5 bar @ 23°C)
- GDZ-02** = PE (polyethylene) 6/4 (6 mm outside-Ø, 4 mm inside-Ø) (10 bar @ 23°C)
- GDZ-03** = PUR (polyurethane) 6/4 (6 mm outside-Ø, 4 mm inside-Ø) (9 bar @ 23°C)
- GDZ-04** = PA (polyamide) 6/4 (6 mm outside-Ø, 4 mm inside-Ø) (25 bar @ 23°C)
- GDZ-05** = Screw-type glanding for 6/4 tube with outside thread G¹/₈"
- GDZ-06** = Increaser glanding for 6/4 tube with inside thread G¹/₈"
- GDZ-07** = Double reducer for tubes with 6 inside-Ø to 6/4 tube
- GDZ-08** = Double adapter for 6/4 tube to 6/4 tube
- GDZ-09** = Coupling adapter (NW5) made of brass with inside thread G¹/₄" (suitable for GDZ-12)
- GDZ-10** = Coupling adapter (NW5) made of brass for tube with 6mm inside-Ø (suitable for GDZ-12)
- GDZ-11** = Coupling adapter (NW5) made of brass with outside thread G¹/₄" (suitable for GDZ-12)
- GDZ-12** = Coupler socket (NW5) made of brass (single-hand use) with inside thread G¹/₄"
- GDZ-17** = Screw-in connection for 6/4 tube with outside thread G¹/₄"
- GDZ-18** = Tube clamp for 6/4 tube
- GDZ-19** = Tube clamp for 8/6 tube (8mm outside-Ø and 6mm inside-Ø)
- GDZ-21** = T-piece for 6/4 tubes
- GDZ-25** = Luer-Lock male to 6/4 tube
- GDZ-26** = Luer-Lock female to 6/4 tube
- GDZ-29** = Filter-Membrane incl. Luer-Locks (GDZ-25 and GDZ-26) (without picture)
- GOG-N** = needle, Ø 0.9 mm - suitable to Luer-Lock male (5 pieces) (without picture)

for additional accessories refer to page 43



Stainless steel pressure sensors:

for use with GMH31xx, GMH 51xx and GDUSB1000 (p.r.t. page 61)

Application: • air, aggressive gases
• aggressive liquids / water, etc.

Follow-on type for **GMSD-**
stainless-steel-sensors

Absolute pressure	Measuring range	Overload	Resolution	MSD 1 BRE	0 ... 1000 mbar rel.	max. 5 bar rel.	1 mbar
MSD 1 BAE	0 ... 1000 mbar abs.	max. 5 bar abs.	1 mbar	MSD 2,5 BRE	0 ... 2500 mbar rel.	max. 10 bar rel.	1 mbar
MSD 2,5 BAE	0 ... 2500 mbar abs.	max. 10 bar abs.	1 mbar	MSD 4 BRE	0 ... 4000 mbar rel.	max. 17 bar rel.	1 mbar
MSD 4 BAE	0 ... 4000 mbar abs.	max. 17 bar abs.	1 mbar	MSD 6 BRE	0 ... 6000 mbar rel.	max. 35 bar rel.	1 mbar
MSD 6 BAE	0 ... 6000 mbar abs.	max. 35 bar abs.	1 mbar	MSD 10 BRE	0,00 ... 10,00 bar rel.	max. 35 bar rel.	10 mbar
MSD 10 BAE	0 ... 10,00 bar abs.	max. 35 bar abs.	10 mbar	MSD 25 BRE	0,00 ... 25,00 bar rel.	max. 50 bar rel.	10 mbar
MSD 16 BAE	0 ... 16,00 bar abs.	max. 80 bar abs.	10 mbar	MSD 40 BRE	0,00 ... 40,00 bar rel.	max. 80 bar rel.	10 mbar
MSD 25 BAE	0 ... 25,00 bar abs.	max. 50 bar abs.	10 mbar	MSD 60 BRE	0,00 ... 60,00 bar rel.	max. 120 bar rel.	10 mbar
Relative pressure	Measuring range	Overload	Resolution	MSD 100 BRE	0,0 ... 100,0 bar rel.	max. 200 bar rel.	0,1 bar
MSD -1/1,5 BRE	-1000 ... +1500 mbar rel.	max. 10 bar rel.	1 mbar	MSD 160 BRE	0,0 ... 160,0 bar rel.	max. 320 bar rel.	0,1 bar
MSD -1/3 BRE	-1000 ... +3000 mbar rel.	max. 17 bar rel.	1 mbar	MSD 250 BRE	0,0 ... 250,0 bar rel.	max. 500 bar rel.	0,1 bar
MSD 100 MRE	0,0 ... 100,0 mbar rel.	max. 1 bar rel.	0,1 mbar	MSD 400 BRE	0,0 ... 400,0 bar rel.	max. 800 bar rel.	0,1 bar
MSD 250 MRE	0,0 ... 250,0 mbar rel.	max. 2 bar rel.	0,1 mbar	MSD 600 BRE	0,0 ... 600,0 bar rel.	max. 1200 bar rel.	0,1 bar
MSD 400 MRE	0,0 ... 400,0 mbar rel.	max. 2 bar rel.	0,1 mbar	MSD 1000 BRE	0 ... 1000 bar rel.	max. 1500 bar rel.	1 bar

MSD ...

Stainless steel pressure sensors without cable

Connection cable MSD-K31 or MSD-K51 has to be ordered separately (Accessories)

MSD-K31

1 m connection cable for MSD-sensors for use with GMH 31xx / GDUSB 1000

MSD-K51

1 m connection cable for GMH 51xx

General Specification

Sensor:	stainless steel pressure sensor (parts coming into contact with media). Suitable for aggressive media, water, etc.
Accuracy: (typ. values)	± 0,2 % FS (hysteresis and linearity) ± 0,2 % FS / K (TC for zero or slope)
Electronics:	PC board with amplifier and data memory for sensor data (meas. range, calibration, etc.) integrated in sensor housing, sealed sensor electronic
Reaction time:	1 ms
Medium temperature:	-25 ... +100 °C (kompensierter Bereich: 0 ... 70 °C)
Working conditions:	-20 ... +80 °C
Storage temperature:	-40 ... +80 °C
Pressure connection:	connection thread G1/2B (other on request).
Cable connection:	M12 built-in plug
Housing:	CrNi-steel (parts coming into contact with media) length: 88,5 mm, Ø 27 mm, approx. 220 g
Protection class:	IP 67 (sensor)

Options / upcharges

Higher probe accuracy

by multi point calibration (additional individual linearisation points are stored in sensor memory)

Certificate of calibration WPD5

Zubehör

MSD-K31 Connection cable for use with GMH 31xx / GDUSB 1000
1 m PVC connection cable, screened with integral 6-pin Mini-DIN-plug and M12-socket (IP 54)

MSD-K51 Connection cable for use with GMH 51xx
1 m PVC connection cable, screened with 7-pin bayonet plug and plug connection water proof acc. to IP 67

MSD-K31-xx

Longer connection cable (as MSD-K31); Length 2 ... 10 m please specify

MSD-K51-xx

Longer connection cable (as MSD-K51); Length 2 ... 10 m please specify

Ex-Ausführung

MSD ... - ex
Stainless steel pressure sensor (without cable) with Ex-protection

MSD-K31 - ex Connection cable with Ex-protection
Connection to GMH 31xx and GDUSB 1000
1 m PVC connection cable, screened with integral 6-pin Mini-DIN-plug and M12-socket



GMSD 1 BTS

well probe / submersible probe:

for use with GMH311x, GMH315x and GDUSB 1000

Application area: measurings in water, aggressive media, etc.

For further information please refer to the homepage www.greisinger.de/

TUBE ADAPTER, COUPLINGS, etc.



for additional accessories p.r.t.p. 42

GDZ-13 = Increaser/reducer made of brass with G¹/₂" outside thread and G¹/₈" inside thread

GDZ-14 = Screw-in nozzle for 6/4 tube with outside thread G¹/₈"

GDZ-15 = Screw-in nozzle for tube with 6 mm inside-Ø with outside thread G¹/₄"

GDZ-16 = Screw-in nozzle for 6/4 tube with outside thread G¹/₄"

GDZ-20 = Screw-on connection made of brass for 6/4 tube with inside thread G¹/₄"

GDZ-22 = Coupling adapter (NW5) made of brass with tube connection 6/4 (suitable for GDZ-12)

GDZ-23 = Adapter G¹/₂" inside thread to G¹/₄" outside thread, made of brass

GDZ-27 = Manometer profile gasket (thickness 3 mm, Cu) for thread G¹/₄"

GDZ-28 = Flat gasket (thickness 5 mm, Cu) for thread G¹/₂"

GDZ-30 = Adapter G¹/₂" inside thread to tube 6/4 (without picture)

GWA 1214 = Adapter G¹/₂" inside thread to G¹/₄" outside thread (without picture)

A series of hand-held measuring devices with integrated sensor



- integrated pressure sensor
- sturdy metal connection pin
- tara function / zero point offset
- model with protection available



Additional features for GMH 3181:

- peak value memory (>1 ms)
- 2 logger functions
- analog output 0 - 1 V
- min-/max- alarm
- integrated horn

DIGITAL-VACUUM- / BAROMETER for measuring of absolute pressure.

GMH 3161-12 (device ready for operation)

GMH 3181-12 (device ready for operation)

0 ... 1300 mbar abs.

Version specific data: ... - 12

Measuring range:	0 ... 1300 mbar absolute
Overload:	max. 4 bar absolute
Resolution:	1 mbar
Pressure units:	mbar, bar, kPa, MPa, PSI, mmHg, mmH ₂ O - freely select able
Accuracy: (typ. values)	
hysteresis and linearity	± 0,2 % FS
temperature-influence from 0-50°C	± 0,4 % FS
Option higher accuracy available	yes
Sensor:	integrated piezo-resistive absolute pressure sensor. Suitable for air and non aggressive gases. (Note: sensor is not suitable for water!)
Pressure connection:	1 metal connection pin, made of brass, nickel plated, pressure tubes 6x1 mm (4 mm inside-Ø) can be connected

For type specific data please refer to page 45

Special function:

SeaLevel-correction: The barometric air pressure can also be related to sea level "zero".
(Correction of air pressure is achieved by entering m above "zero")

Options (upcharges)

Higher sensor accuracy
by multi point calibration
Note: not possible for all device types!

Certificate of calibration WPD5
(f. ISO9000 ff.) incl. several calibration points of sensor (stored in device memory), Certificate of calibration: 5 points increase, 5 points decrease.

Certificate of calibration WPD10
(f. ISO9000 ff.) incl. several calibration points of sensor (stored in device memory), Certificate of calibration: 10 points increase, 10 points decrease.

Special design type (upcharges)

Ex-protection (Ex II 2 G Ex ib IIC T4)
device type with Ex-protection
(please refer to notes at page 40)



Accessories:

- GNG 10/3000** plug-in power supply
- GKK 3000** case (275 x 229 x 83 mm) with cut-outs for GMH3xxx
- GRS 3100** interface converter, RS232, electrically isolated
- USB 3100 N** interface converter, USB, electrically isolated
- GDZ-01** PVC-tube (5bar) 6/4 (6mm outside-Ø, 4mm inside-Ø)
- GDZ-08** Double adapter for 6/4 tube to 6/4 tube
- GDZ-18** tube clamp for 6/4 tube
- GDZ-21** T-piece for 6/4 tubes

for miscellaneous accessories
p.r.t. pages 42 - 43, 56 - 58

General function description:

- Tare function:** display value and the min./max values memorized can be set to zero.
- Hold function:** by pressing a button the current meas. value will be memorized.
- Min./Max. value memory:** memorizing of max. and min. values.
- Serial interface:** direct connection to RS232 or USB interface of a PC via electrically isolated interface adapter GRS3100, GRS3105 or USB3100.
- Power-Off-function:** device will be automatically switched off if no operating takes place for the time of the power-off delay. Selectable values: off, 1 ... 120 min.
- Peak value memory (peak-detect):** In the min-/max-value memory will be detected not filtered pressure peaks ≥1msec.
- Logger operation:** Logger start and stop via the keyboard or interface. Comfortable read-out and display software (GSOFT3050) available as additional equipment.
- Low power logger mode:** (only in measuring cycle "slow") Only one measurement carried out at the end of the respective logger cycle. The battery life is considerably prolonged. For long-term recordings (eg. tightness).
- Averaging function:** integrates the meas. values during a selectable period of time and then calculates the average display value.
- Min-/Max-alarm:** the measuring value is constantly monitored if they remain within the min./max. limits set (deactivateable)
- **Alarm:** 3 different alarm settings
 - "off" - alarm function deactivated
 - "on" - visual alarm via display, interface alarm, alarm sounded via integrated horn.
 - "no.So." - visual alarm via display and interface alarm
- **Controlling function:** with the help of the switching module GAM3000 (optionally) electric equipment can be switched on/off or alarm monitored (see accessories)

DIGITAL-FINE MANOMETER / MANOMETER for over/under pressure and pressure difference.



GMH 3161-01

GMH 3181-01

-100 ... 2500 Pa (± 2500 Pa ^{*1})

GMH 3161-07H

-1,00 ... 70,00 mbar ($\pm 70,00$ mbar ^{*1})

GMH 3161-07

GMH 3181-07

-10,0 ... 350,0 mbar ($\pm 350,0$ mbar ^{*1})

GMH 3161-07B

-10,0 ... 420,0 mbar (-7,5 ... 315,0 mmHg)

GMH 3161-13

GMH 3181-13

-100 ... 2000 mbar (± 2000 mbar ^{*1})

Option, upcharge:

MB -1...2 BAR

measuring range: -1000 ... 2000 mbar ^{*2}

Version specific data: ... -01 ... -07H ... -07 ... -07B ... -13

Measuring range:	-100 ... 2500 Pa (-1,00 ... 25,00 mbar)	-1,00 ... +70,00 mbar	-10,0 ... +350,0 mbar	-10,0 ... +420,0 mbar (-7,5 ... 315,0 mmHg)	-100 ... 2000 mbar (optional: -1000 ... 2000 mbar)
Overload:	max. 100 mbar	max. 1000 mbar	max. 1 bar	max. 1 bar	max. 4 bar
Resolution:	1 Pa (0,01 mbar)	0,01 mbar	0,1 mbar	0,1 mbar (0,1 mmHg)	1 mbar
additional pressure units:	bar, kPa, PSI, mmHg, mH ₂ O	bar, Pa, kPa, PSI, mmHg, mH ₂ O	bar, kPa, MPa, PSI, mmHg, mH ₂ O	bar, kPa, MPa, PSI, mH ₂ O	bar, kPa, MPa, PSI, mmHg, mH ₂ O

(typ. values)					
hysteresis and linearity	$\pm 0,3$ % FS	$\pm 0,1$ % FS	$\pm 0,2$ % FS	$\pm 0,1$ % FS	$\pm 0,2$ % FS
temperature-influence from 0-50°C	$\pm 0,4$ % FS	$\pm 0,4$ % FS	$\pm 0,4$ % FS	$\pm 0,4$ % FS	$\pm 0,4$ % FS
Option higher accuracy available	no	already integrated	yes	already integrated	yes

Sensor: integrated piezo-resistive absolute pressure sensor.
Suitable for air and non aggressive. (Note: sensor is not suitable for water!)

Pressure connection: 2 metal connection pin, made of brass, nickel plated, pressure tubes 6x1 mm (4 mm inside-Ø) can be connected

^{*1} measuring range possible by changing the pressure connection ports

^{*2} without changing the pressure connection ports

Type specific data: GMH 3161 - ... GMH 3181 - ... GMH 3160 - ... - ex GMH 3180 - ... - ex

Display:	2 x 4½-digit LCD	2 x 4½-digit LCD	2 x 4½-digit LCD	2 x 4½-digit LCD
Output:	interface	interface or AAG	interface*	interface or AAG*
- serial interface:	X	X	X	X
- analog output:	--	0 - 1V, freely adjustable (resolution 12 bit)	--	0 - 1V, freely adjustable (resolution 12 bit)
Power supply:	9V-battery, d.c. connector <i>suitable 9V-battery (type IEC 6F22) in scope of supply, d.c. connector for external 10.5-12V direct voltage supply. (suitable power supply: GNG10/3000)</i>	9V-battery, d.c. connector	9V-battery, d.c. connector*	9V-battery, d.c. connector*
Sensor adjustment:	digital offset and scale input	digital offset and scale input	digital offset and scale input	digital offset and scale input
Tare, hold, min/max value:	X	X	X	X
Peak value memory:	--	≥ 1 ms	--	≥ 1 ms
Measuring cycle: "slow"	4 measurements / s	4 measurements / s	4 measurements / s	4 measurements / s
"fast" (with filter)	--	≥ 1000 meas. / s	--	≥ 1000 meas. / s
"peak-detect"	--	≥ 1000 meas. / s	--	≥ 1000 meas. / s
Logger functions:	--	X	--	X
-manually:	--	99 data sets	--	99 data sets
-cycle:	--	10000 data sets (max. 64 recording sequen.)	--	10000 data sets (max. 64 recording sequences)
-adjustable cycle time:	--	1 ... 3600 seconds	--	1 ... 3600 seconds
Averaging function:	--	X	--	X
Min-/max-alarm:	--	X	--	X*
Real-time clock:	--	X	--	X
Power consumption:	approx. 0.6 mA	approx. 0.6 mA (slow mode) max. 2.5 mA (fast = 1000Hz)	max. 0.6 mA	max. 0.6 mA (slow mode) max. 2.5 mA (fast = 100Hz)
Working condition:	-25 to +50 °C, 0 to +95 %RH (non-condensing)	-25 to +50 °C, 0 to +95 %RH (non-condensing)	-10 to 50 °C, 0 to 95 %RH (non-condensing)	-10 to 50 °C, 0 to 95 %RH (non-condensing)
Housing dimensions:	142 x 71 x 26 mm (without pressure connection pin - pin approx. 11 mm protruding at front side of device), impact-resistant ABS plastic housing. Front side IP65	integrated pop-up clip for table top or suspended use.	--	--
Weight:	approx. 165 g	approx. 170 g	approx. 205 g (incl. case)	approx. 210 g (incl. case)

* Please refer to note to Ex-design types at page 40



FINE MANOMETER for over/under pressure or pressure difference

GDH 200 - 07

0.00 to 19.99 / 199.9 mbar (± 199.9 mbar)

Device ready for use incl. battery

Functions:

- Autorange
- Excellent zero point stabilisation
- Manual slope adjustment
- 4 selectable measuring units: Pa, mbar, mmHg, PSI
- automatic off-function: 1 ... 120 Min

Specification

Measuring range:

0.00 ... 19.99 resp. 20.0 ... 199.9 mbar (hPa)

0.00 ... 19.99 resp. 20.0 ... 150.0 mmHg

0.000 ... 1.999 PSI / 0 ... 1999 Pa

Resolution: automatic change 0.1 / 0.01

Overload: max. 500 mbar

Accuracy: (at nominal temperature = 25 °C and automatic Zero point-adjustment)

Measuring range: up to 200 mbar

$\pm 0,2$ % f.s. hysteresis and linearity

$\pm 0,4$ % f.s. temperature drift from 0 to 50 °C

Measuring range: up to 20 mbar

± 1 % f.s. hysteresis and linearity

± 2 % f.s. temperature drift from 0 to 50 °C

Sensor: piezoresistive relative pressure sensor

Pressure connection: 2 pressure port sockets made of nickel-plated brass, for flexible pressure tubings 6x1 mm (4 mm inner-diameter), approx. 11 mm protrusive.

Working temperature: -25 to 50 °C

Display: 3½ digit LCD display, approx. 13 mm high

Pushbuttons: 3 membrane keys

Power supply: 9V battery type JEC 6 F 22 (included)

Power consumption: approx. 250 μ A (= 1200 operating hours)

Low battery warning: „BAT“, automatic

Housing: impact resistant ABS plastic housing

Dimensions: approx. 106 x 67 x 30 mm (H x W x D) without pressure port sockets

Weight: approx. 135 g (incl. battery)

Auto-Off-Function: 1...120 min (can be deactivated either).

Min./Max. value memory: Memorizing of max. and min. values.

Zero point-adjustment: automatically

Slope-adjustment: manually

Zero function: Display value and min-/max value are set to null.

Tubes, clamps, adapters, accessories, etc. p.r.t. pages 42/43, 56/58



MANOMETER for over/under pressure or pressure difference

GDH 200 - 13

0.0 to 199.9 / 1999 mbar (± 1999 mbar)

Device ready for use incl. battery

Functions:

- Autorange
- Excellent zero point stabilisation
- Manual slope adjustment
- 3 selectable measuring units: mbar, mmHg, PSI
- automatic off-function: 1 ... 120 Min

Specification

Measuring range:

0.0 ... 199.9 resp. 200 ... 1999 mbar (hPa)

0.0 ... 199.9 resp. 200 ... 1500 mmHg

0.00 ... 19.99 PSI

Resolution: automatic change 1 / 0.1

Overload: max. 4000 mbar

Accuracy: (at nominal temperature = 25 °C and automatic Zero point-adjustment)

Measuring range: up to 2000 mbar

$\pm 0,2$ % f.s. hysteresis and linearity

$\pm 0,4$ % f.s. temperature drift from 0 to 50 °C

Measuring range: up to 200 mbar

± 1 % f.s. hysteresis and linearity

± 2 % f.s. temperature drift from 0 to 50 °C

Sensor: piezoresistive relative pressure sensor

Pressure connection: 2 pressure port sockets made of nickel-plated brass, for flexible pressure tubings 6x1 mm (4 mm inner-diameter), approx. 11 mm protrusive.

Working temperature: -25 to 50 °C

Display: 3½ digit LCD display, approx. 13 mm high

Pushbuttons: 3 membrane keys

Power supply: 9V battery type JEC 6 F 22 (included)

Power consumption: approx. 250 μ A (= 1200 operating hours)

Low battery warning: „BAT“, automatic

Housing: impact resistant ABS plastic housing

Dimensions: approx. 106 x 67 x 30 mm (H x W x D) without pressure port sockets

Weight: approx. 135 g (incl. battery)

Auto-Off-Function: 1...120 min (can be deactivated either).

Min./Max. value memory: Memorizing of max. and min. values.

Zero point-adjustment: automatically

Slope-adjustment: manually

Zero function: Display value and min-/max value are set to null.

Tubes, clamps, adapters, accessories, etc. p.r.t. pages 42/43, 56/58



VAKUUM-/BAROMETER and MANOMETER for absolute pressure

GDH 200 - 14

0 to 11000 mbar abs.

Device ready for use incl. battery

Functions:

- Sea level-adjustment possible
- suitable for relative pressure measurement (-1...10 bar) by use the zero function
- Manual slope and offset adjustment
- 4 selectable measuring units: mbar, mmHg, bar, PSI
- automatic off-function: 1 ... 120 Min

Specification

Measuring range:

0 ... 11000 mbar (hPa) abs.

0 ... 8250 mmHg abs.

0.000 ... 11.000 bar abs.

0.00 ... 160.00 PSI abs.

Resolution: 1 mbar, 1 mmHg, 0.001 bar, 0.02 PSI

Overload: max. 13 bar abs.

Accuracy: (at nominal temperature = 25 °C)

± 3 mbar or 0,1 % of m.v. (whichever is higher)

$\pm 0,3$ % f.s. temperature drift from 0 to 50 °C

Sensor: piezoresistive absolute pressure sensor

Pressure connection: pressure port socket made of nickel-plated brass, for flexible pressure tubings 6x1 mm (4 mm inner-diameter), approx. 11 mm protrusive.

Working temperature: -25 to 50 °C

Display: 4½ digit LCD display, approx. 12 mm high

Pushbuttons: 3 membrane keys

Power supply: 9V battery type JEC 6 F 22 (included)

Power consumption: approx. 40 μ A (= 7500 operating hours)

Low battery warning: „BAT“, automatic

Housing: impact resistant ABS plastic housing

Dimensions: approx. 106 x 67 x 30 mm (H x W x D) without pressure port socket

Weight: approx. 135 g (incl. battery)

Sea level-adjustment: barometric air pressure can be displayed null based even at sea level.

(the pressure-adjustment is entered in metres above "null")

Auto-Off-Function: 1...120 min (can be deactivated either).

Min./Max. value memory: Memorizing of max. and min. values.

Zero point-adjustment: automatically

Slope-adjustment: manually

Zero function: Display value and min-/max value are set to null.

Tubes, clamps, adapters, accessories, etc. p.r.t. pages 42/43, 56/58



BAROMETER

GPB 3300

Device ready for use incl. battery

Functions:

- manual offset and slope adjustment
- sea level-adjustment possible
- 2 measuring units selectable: mbar, mmHg
- Auto-off-function: 1...120 Min

Specification

Measuring ranges:

300.0 ... 1100.0 mbar (hPa) abs.
225.0 ... 825.0 mmHg abs.

Max. Overload: 4000 mbar resp. 300 mmHg

Accuracy: (at nominal temperature)
± 2.0 mbar (typ., at 0 - 50 °C)

Sensor: piezoresistive abs. pressure sensor
integrated in housing.

Nominal temperature: 25°C

Operating temperature: -25 to 50 °C

Display: 4½-digit, 12 mm high LCD-display

Pushbuttons: 3 membrane key for ON/OFF,
min-/max-value memory, tara, etc.

Power supply: 9V battery type IEC 6F22

Power consumption: approx. 60 µA
(= 5000 operating hours)

Low battery warning: „BAT“, automatic

Housing: impact resistant ABS housing

Dimensions: approx. 106 x 67 x 30 mm (HxWxD)

Weight: approx. 135 g (incl. battery)

Sea level-adjustment: barometric air pressure
can be displayed null based even at sea level.
(the pressure-adjustment is entered in metres
above "null")

Auto-Off-Function: 1...120 min (can be deacti-
vated either).

Min./Max. value memory: Memorizing of max.
and min. values.

Zero point-adjustment: automatically

Slope-adjustment: manually

Zero function: Display value and min-/max value
are set to null.

Accessories

GKK 252 small case
(235 x 185 x 48 mm) with foam lining

GB 9 V spare battery

other accessories p.r.t. page 56/58



altimeter / barometer / thermometer

GTD 1100

Device ready for use incl. battery

Functions:

- manual offset and slope-adjustment
- sea level-adjustment possible
- tendency-meter, summing-function (ascendency, descendency, overall)
- over 6.000 operating hours

Specification

Measuring ranges:

Temperature:	-10,0 ... +50,0°C,	Res. 0,1°C	or	14,0 ... +122,0°F,	Res. 0,1°F
Pressure:	300,0 ... 1100,0mbar,	Res. 0,1mbar	or	225,0 ... 825,0mmHg,	Res. 0,1mmHg
High:	-500 ... -200m,	Res. 1m	or	-1640 ... -655ft,	Res. ~5ft
	-200 ... 2000m,	Res. 0.5m	or	- 654 ... 1999ft,	Res. ~2ft
	2000 ... 9000m,	Res. 1m	or	2000 ... 19999ft,	Res. ~5ft

Measuring units: hPa / mbar, mmHg, °C, °F, m, ft

Max. Overload: pressure:4000 mbar resp. 3000 mmHg

Accuracy: (at nominal temperature = 25°C)

Temperature: ±1% FS ± 1digit

Absolute pressure: ±1.5mbar ±1 digit (750...1100mbar), with certificate of calibration: ±0.5mbar ± 1digit

Sensor: piezoresistive absolute pressure sensor, integrated in housing.

Operating conditions: -10 to 50 °C; 0 to 80 %RH (non condensing)

Storage temperature: -20 to 70 °C

measuring-frequency: 1 measurings / sec.

Display: approx. 12 mm high, 4½-digit LCD-display

Controls: keypad (3 push-buttons) for On/off, min-/max-value, tara-function, zero-, slope-,
and sea level-adjustment slide switch for unit selection.

Power supply: 9V battery type IEC 6F22 (included)

Power consumption: approx. 50 µA (= over 6.000 operating houres with standard zinc carbon batteries)

Low battery warning: „BAT“, automatic in case of low voltage

Housing: impact resistant ABS housing, lucent screening grid. front IP65

Dimensions: approx. 106 x 67 x 30 mm (H x W x D)

Weight: approx. 135 g (incl. battery)

Sea level-adjustment: barometric air pressure can be displayed null based even at sea level. (the
pressure-adjustment is entered in metres above "null")

Tendency-meter: for fallng / rising air pressure

Sum-function: Displaying the elevation (in metres for ascendency, descendency, overall)

Min./Max. value memory: Memorizing of max. and min. values.

Zero function: Display-value, min-/max-value are set to null (altitude and air pressure)

Auto-Off-Function: 1...120 min (can be deactivated either).

Zero point- and slope-adjustment: manual adjustment (for temperature and air pressure)

Zero function: Display- and min-/max-value are set to null.

System Notifications: permanent self-diagnosis and error indication.

Accessories

GKK 252 small case
(235 x 185 x 48 mm) with foam lining

GB 9 V spare battery

other accessories p.r.t. page 56/58

Precision barometer

for professional usage in measurement
technology as well as in spare time
sports

- resolution 0.1 mbar
- for simple determination of a build-
ing size (steeples, skyscrapers,
bridges, etc.)
- further application areas:
hiking, hang gliding, cycling, motor-
sports, etc.

Certificate of calibration, WPD 5
5 points rising, 5 points falling

calibration certificate, p.r.t. page 4

pressure measuring instruments with analog output 0 - 1 V



DIGITAL MANOMETER for over/under pressure or pressure difference

GDH 01 AN (0...1999 Pa)

GDH 07 AN (0...199,9 mbar)

Device ready for use incl. sensor (plug-in), battery and mains operation possible, analog output: 0-1V

Specification:

Measuring range:

GDH 01 AN
0 ... 1999 Pa relative
(0 ... 19.99 mbar)
max. 10000 Pa rel.

Overload: (no destruction or new calibration of sensor)

Resolution:

1 Pa (0,01 mbar)

Accuracy (device):

1 Pa ± 1 digit
(at nominal temperature = 25°C)

Temperature drift (device):

$\pm 0,01$ %/K

Sensor: (relative pressure)

piezoresistive relative pressure sensor, externally mounted in plastic case, 2 connection pins for plastic tube 6 x 1 mm (4 mm inner \varnothing), approx. 1 m of 4-wire PVC connecting cable with Mini-DIN 4-pin plug.

Sensor: (absolute pressure)

piezoresistive absolute pressure sensor, externally mounted in plastic case, 1 connection pins for plastic tube 6 x 1 mm (4 mm inner \varnothing), approx. 1 m of 4-wire PVC connecting cable with Mini-DIN 4-pin plug.

Application area:

Sensor suitable for air and non aggressive gases and liquids.

Sensor accuracy: (typical values)

hysteresis and linearity

$\pm 0,5$ % f.s.

$\pm 0,2$ % f.s.

$\pm 0,2$ % f.s.

$\pm 0,2$ % f.s.

$\pm 0,2$ % f.s.

temperature drift (0 - 50°C)

$\pm 0,4$ % f.s.

$\pm 0,4$ % f.s.

$\pm 0,4$ % f.s.

$\pm 0,4$ % f.s.

$\pm 0,4$ % f.s.

for option double accuracy

$\pm 0,1$ % / $\pm 0,2$ % f.s.

$\pm 0,1$ % / $\pm 0,2$ % f.s.

$\pm 0,1$ % / $\pm 0,2$ % f.s.

$\pm 0,1$ % / $\pm 0,2$ % f.s.

Working temperature:

0 to 50 °C (device)

-40 to +85°C (sensor), Temperature of sensor will be compensated from 0 to 70° C

Display:

3½ digit LCD display, approx. 13 mm high

Power supply:

9V battery type JEC 6 F 22 (included).

Additional power supply socket for 2.5 mm \varnothing jack connector (automatic battery disconnection)

Power consumption:

approx. 5 mA

Low battery warning:

„BAT“

Analog output:

0...1 V = 0...1999 Pa 0...1 V = 0...199,9 mbar 0...1 V = 0...1300 mbar 0...1 V = 0...1999 mbar 0...1 V = 0...10,00 bar

socket for 3,5 mm \varnothing jack connector (included)

Dimensions:

approx. 150 x 86 x 30 mm (H x W x D), impact resistant ABS plastic housing with integrated pop-up clip for table-top or suspended use, clips for lateral mounting of probe.

Dimensions sensor case:

approx. 26 x 67.5 x 15 mm (H x W x D) with suspension eye.

Weight:

approx. 320 g (incl. battery and sensor)

Options:

sensor with higher accuracy

Accessories:

GB 9 V spare battery

GNG 10 power supply

GAK 9 V accu 9V

GLG 1300 accu charger for charging of two 9V accu at the same time

GKK 252 small case

(235 x 185 x 48 mm) with foam lining

GKK 1100 case

(340 x 275 x 83 mm) with foam lining for universal use

GKK 3000 case

(275 x 229 x 83 mm) with punched lining suitable for all devices of the GMH3xxx-series

GKK 3100 case

(275 x 229 x 83 mm) with foam lining for universal use

additional accessories p.r.t. page 56/58

DIGITAL MANOMETER for over/under pressure or pressure difference

GDH 13 AN (0...1999 mbar)

GDH 14 AN (0...10,00 bar)

Device ready for use incl. sensor (plug-in), battery and mains operation possible, analog output: 0-1V

DIGITAL-VAKUUM-/BAROMETER for absolute pressure measurements

GDH 12 AN

Device ready for use incl. sensor (plug-in), battery and mains operation possible, analog output: 0-1V

Accessories: (for pressure connection)

GDZ-01 PVC-tube (5bar)

6/4 (6mm outside- \varnothing , 4mm inside- \varnothing)

GDZ-08 Double adapter for 6/4 to 6/4 tube

GDZ-16 Reducer for 6/4 tube with external thread G1/4"

GDZ-18 Tube clamp for 6/4 tube

GDZ-21 T-piece for tubes 6/4

additional tubes, clamps, accessories, etc. p.r.t. page 42, 43

Oxygen (O₂) handheld instruments



Application:	Device	GMH 3610	GMH 3630	GOX 20	GMH 3691 +Sensor	GOX 100	GOX 100T
Meas. of dissolved oxygen in liquids		✓	✓	✓			
Meas. of air oxygen					✓	✓	✓
O ₂ -Concentration		✓	✓	✓	✓	✓	✓
O ₂ -partial pressure			✓		✓		
O ₂ -saturation		✓	✓				
Inert gases					✓		
Fishkeeping		✓	✓	✓			
Diving application					✓		✓

Function / Equipment:	Device	GMH 3610	GMH 3630	GOX 20	GMH 3691	GOX 100	GOX 100T
Specification							
Meas. range							
O ₂ -concentration		0..25 mg/l	0..70 mg/l	0..20 mg/l	0..100 %	0..100 %	0..100 %
O ₂ -partial pressure		--	0..1200 hPa	--	0..1100 hPa	--	--
O ₂ -saturation		0..300 %	0..600 %	--	--	--	--
Temperature		0..50 °C	0..50 °C	0..40 °C	-5..50 °C	--	--
Pressure		--	500..1100 hPa abs.	--	--	--	--
Electrode / sensor		incl. oxygen electrode (changeable)			not included	oxygen-partial pressure probe, mounted in external sensor housing	
Connection		6-pole Mini-DIN socket	6-pole Mini-DIN socket	fixed connection	6-pole Mini-DIN socket	0,7 m cable with jack connector	
Functions							
General functions		Min/Max, Hold, Auto-Off	Min/Max, Hold, Auto-Off, Correction of salinity		Min/Max, Hold, Auto-Off	Min- / Max, Hold, Auto-Off	Min/Max, Hold, Auto-Off, MOD-Display
Interface			✓		✓		
Alarm					✓		
Catalog page		p. 52	p. 52	p. 52	p. 50	p. 51	p. 51

Handheld instrument

Display / Controller

Logger / EASYBus

Transmitter

Temperature probe

Alarm / Protection

Residual oxygen meas. device

for quick and cost-effective measurement of residual oxygen



GMH 3691 GOG

Application:

Essentially there, where delicate products are conserved by low-oxygen atmospheres (protective gas), this instrument is suitable to check the residual oxygen content.

- packaging industry
- food industry

Specification: (summary)

Meas. range: 0,0 ... 100,0 % O₂ (O₂-concentration)

Accuracy: (whole system - during carefully calibration and measuring)

- 1-point-calibration: $\pm 0.2\% \text{O}_2 \pm 1$ digit (for concentrations < 10%)
- 2-point-calibration: $\pm 0.1\% \text{O}_2 \pm 1$ digit (for concentrations < 10%)

Oxygen probe: Oxygen-partial pressure probe, built in external sensor housing

Response time: T₉₀ < 10 sec., depending on temperature

Operation life: warranty for sensor element 12 months (appropriate application and ambient pressure)

Working pressure: 0.5 to 2.0 bar abs.

Over-/under-pressure: max. 0,25 bar

Working temperature: 0 to 50°C (sensor), -20 to 50°C (device)

Relative humidity: 0 to +95%RH (non-condensing)

Storage temperature: -15 to 60°C (sensor), -20 to 70°C (device)

Power supply: 9V battery type IEC 6F22

Dimensions case: approx. 394 x 294 x 106 mm

Weight: approx. 1400g (cpl. set)

for additional technical data refer to GMH3691 and accessory sensors p. 51

Scope of supply:

Instrument GMH3691, hand pump with air tube, GOG oxygen sensor with penetration needle, case GKK3500, spare needle $\varnothing 0,9$ mm, rubber foam sticker (40 pieces), operating manual.

Spare elements, accessories:

GOG-SET Set without instrument

Scope of supply: GOG oxygen sensor with penetration needle, hand pump with air tube, case GKK3500, spare needle and 40 rubber foam sticker

GOEL 370 spare sensor element

GOG-N needle, $\varnothing 0.9$ mm (5 pieces)

GOG-A rubber foam sticker (40 pieces)

ST-R1 device protection bag with cut-out for probe connection

for add. accessories p.r.t. page 56 - 58

Air oxygen measuring device



- Double display for oxygen and temperature
- Measured units: O₂-concentration and O₂-partial pressure
- Alarm detector with integrated horn
- Automatic temperature compensation
- Min./Max. value memory, Hold function
- Serial interface, device can be connected to bus system (up to 5 devices can be connected to one PC interface)
- Battery and d.c. operation
- Wide range of application
- Most simple calibration in atmospheric air

GMH 3691 Sensor not included - please order separately!

Specification:

Measuring ranges:

Oxygen concentration: 0,0 ... 100,0 % O₂ (gaseous)

Partial oxygen pressure: 0 ... 1100 hPa O₂

Temperature: -5,0 ... 50,0 °C

Accuracy: (device) (at nominal temperature = 25°C)

Oxygen concentration: $\pm 0.1\% \pm 1$ digit

Partial oxygen pressure: ± 1 hPa ± 1 digit

Temperature: $\pm 0.1^\circ\text{C} \pm 1$ digit

Oxygen electrode: for suitable sensores p.r.t. page 51

Sensor connection: 6-pin screened Mini-DIN-socket.

Display: two 4 digit LCDs (12.4mm or 7mm high), as well as additional arrows.

Pushbuttons: 6 membrane keys for ON/OFF-switch, selection of meas. range, min- and max-value memory, hold-function, calibration etc.

Working temperature: 0 to +50°C

Relative humidity: 0 to +95%RH (non-condensing)

Storage temperature: -20 to +70°C

Interface: serial interface, direct connection to RS232 or USB interface of a PC via electrically isolated interface converter GRS3100 or GRS3105 resp. USB3100 (p.r.t. accessories).

Power supply: 9V-battery, type IEC 6F22 (included), as well as additional d.c. connector for external 10.5-12V direct voltage supply. (suitable power supply: GNG10/3000)

Power-Off-function: 1...120min (can also be deactivated).

Power consumption: approx. 1.5 mA

Low battery warning: Δ and 'bAt'

Dimensions: 142 x 71 x 26 mm (H x W x D) Impact-resistant ABS plastic housing, membrane keyboard, transparent panel. Front side IP65, integrated pop-up clip.

Weight: approx. 160 g (cpl. with battery)

Functions:

Min-/Max-value memory: max. and min. values will be memorized.

Hold function: by pressing a button the current meas. value will be memorized.

Alarm: integrated limit detector for min. or max. alarm.

Temperature compensation: automatic via temperature sensor, integrated in probe housing.

Air pressure compensation: The O₂ concentration will be compensated according to the abs. atmospheric pressure set (500...2000hPa).

Calibration: 1-point calibration: extremely simple quick calibration in atmospheric air. (press button to compensate unit to 20.9%).

2-point calibration: first point at atmospheric air (20.9%), second point freely selectable

Application:

Wide range of application for your home, job and hobby! For example:

- **Bio chemistry:** Oxygen monitoring in breeding chambers for cell cultures. Monitoring of fermenting process of fruits in fermentation plants etc.

- **Medicine:** Monitoring of oxygen concentration in respirators; checking of breathing, monitoring of oxygen concentration in incubators, oxygen tents etc.

- **Food technology:** Monitoring of residual oxygen in packages (e.g. coffee, tea, etc.). Monitoring of oxygen content during production processes.

- **Air conditioning and ventilation technology:** Oxygen measurements, air quality monitoring, measuring of oxygen concentration in enclosed air conditioning systems, etc.

- **Sport:** Checking of oxygen content in compressed air breathing apparatuses (diving, etc.), oxygen monitoring for gliding.

The device can only be used to check during these applications. -> no substitute for approved monitoring device!

Accessories:

Suitable sensores p.r.t. page 51

GKK 3000 case (275 x 229 x 83 mm) with punched lining suitable for GMH3xxx

USB 3100 N interface converter, electrical isolated

GRS 3105 interface converter with 5 connection points, electr. isolated, for the connection of 5 GMH3xxx to one PC (RS232).

ST-R1 device protection bag with cut-out for probe connection

for add. accessories p.r.t. pages 56 - 58

Atmospheric oxygen sensors for devices of the GMH369x series

closed sensor type



- suitable for under and over pressure
- for using in gas-tight systems

Application:

Suitable for measuring in normal atmosphere and in systems without or with slight under or over pressure. The sensor type features a screw thread and can be built in gas-tight in almost every system directly resp. with tube-adaptor

GGO 370

universal applications, diving,
O₂ sensor for high CO₂ concentration

Specification:

Application:

Specific features:

Measuring range:

Partial oxygen pressure: 0 ... 1100 hPa O₂

Oxygen concentration: 0,0 ... 100,0 % O₂

Temperature: 0,0 ... 45,0 °C

Response time: T₉₀ <10 sec.

Operating conditions: 0 - 45 °C

0 - 95 %RH

Ambient pressure: 0,5 to 2,0 bar abs.

Over-/under-pressure: max. 0,25 bar

(pressure difference sensor membrane to ambient – sensor screwed-in)

Storage temperature: -15 to +60 °C

Operation life: approx. two years (warranty for sensor element: 12 months)

Sensor: GOEL 370

Oxygen-partial pressure probe, mounted in external sensor housing approx. 1,3 m cable with Mini-DIN-plug.

Connection: GGO...: approx. Ø 36 mm x 95 mm (150 mm incl. anti-buckl. glanding),

GOO...: approx. Ø 40 mm x 105 mm (160 mm incl. anti-buckl. glanding)

Housing with M16 x 1-screw thread (sensor can be connected to line tubes by means of an additional adapter)

approx. 135 g (GGO...) or approx. 145 g (GOO...)

Weight: GGO... : sensor, flow diverter, T-piece

GOO... : sensor, flow diverter

Options: (for all types)

cable length 4m

cable length 10m

Spare elements, accessories:

GOEL 370 spare sensor element for replacement by user

GZ-11 flow rate adapter to measure the oxygen concentration with 6/4 mm tube

ESA 369 spare tube-adaptor M16x1, for tubes with a inner-diameter of 15mm 



open sensor type



- suitable for air- or gas-stream
- quick temperature compensation

Application:

Because of the special sensor construction the measuring gas streams optimally around the sensor and escapes through holes in the housing into the air. No pressure build-up at slight streaming of the probe, that falsify the result of measurement. Particularly suitable for measuring of gas out of gas-bottle etc. Even measuring indoor-gas concentration is possible.

GOO 370

universal applications, diving,
O₂ sensor for high CO₂ concentration

Compact air oxygen meas. device



GOX 100

for universal applications

- 1-Button Calibration
- Automatic Power-Off
- Min-/max- value memory
- Incl. sensor GOEL 370

GOX 100T

for diving applications

- 1-Button Calibration
- MOD-Display (Maximum Operating Depth)
- HOLD function
- Incl. sensor GOEL 370

Specification:

Meas. range: 0,0 ... 100,0 % O₂

Accuracy typ.: ± 0,1 % O₂ ± 1 digit

calibrated device (range from 15 to 40 % O₂)

MOD (GOX 100T): 0 ... 100 m / 0 ... 199 ft

Sensor Connection: jack-connector cable

Sensor: Oxygen-partial pressure probe, mounted in external sensor housing

Warranty: 12 months

Working pressure: 0,5 to 2,0 bar absolute

Over-/under-pressure: max. 0,25 bar

Working temperature: 0 to 45°C (sensor)
-20 to 50°C (device)

Relative humidity: 0 to +95%RH

Power supply: 9V battery type IEC 6F22

Power consumption: approx. 120µA (over 2500 h)

Display: 3½-digit, 13mm high LCD-display

Housing: ABS-enclosure, front side IP65

Dimensions: approx. 106 x 67 x 30 mm

Weight: approx. 185g

Features: **BAT, Auto-Power-Off**

Scope of supply:

Device incl. sensor, T-piece, flow diverter

Options:

- **LACK** encapsulated PC board
(for applications where condensation is possible)

Spare peaces, accessories:

GOEL 370 spare sensor

ESA 369 spare tube-adaptor

ZOT 369 spare T-piece

GKK 252 case (235 x 185 x 48 mm)
with foam lining

for add. accessories p.r.t. page 56 - 58

Oxygen measuring devices for dissolved oxygen in liquids



- Double display for oxygen and temperature
- Meas. units: O₂-concentration, O₂-saturation and O₂-partial pressure (GMH3630 only)
- Automatic air pressure compensation
- Salinity correction
- Extremely small measuring probe
- Min./Max. value memory, Hold function
- Serial interface
- Battery and d.c. operation
- Simple calibration in atmospheric air

GMH 3610 incl. oxygen electrode

GMH 3630 incl. oxygen electrode

Difference between GMH3630 and GMH3610:

Additional features of GMH3630:

- Measuring of air pressure by means of integrated pressure sensor

- Extended measuring range for O₂
- O₂-partial pressure measurement
- Correction of salinity

Specification :

Measuring ranges:

O₂-concentration:

3610: 0,0 ... 25,0 mg/l
3630: 0,0 ... 70,0 mg/l / 0,00 ... 25,00 mg/l

O₂-saturation:

3610: 0 ... 300 %
3630: 0 ... 600 % or 0,0 ... 250,0 %

O₂-partial pres.:

3630: 0 ... 1200 hPa or 0,0 ... 570,0 hPa
(0,0 ... 427,5 mmHg / 0 ... 900 mmHg)

Temperature:

3610 / 3630: 0,0 ... 50,0 °C

Pressure:

3630: 500 ... 1100 hPa abs.

Accuracy: (at nominal temperature = 25°C)

Oxygen:

3610: ±1,5% of m.v. ±0.2 mg/l
3630: ±1,5% of m.v. ±0.2 mg/l (0...25mg/l)
±2,5% of m.v. ±0.3 mg/l (25...70mg/l)

Temperature:

±0,1°C ±1digit

Pressure:

±0,5% FS ±1digit

Sensor connection:

6-pin screened Mini-DIN-socket.

Electrode:

active membrane type. Electrode-Ø front: approx. 12mm, overall length: approx. 220 mm, anti buckling glanding, neck collar: Ø approx. 20 mm, 4 m connection cable with Mini-DIN-plug.

Response time:

95% in 10sec., dep. on temperature.

Operation life:

approx. 3 years or more, dep. on maintenance

Working temp.:

0 to +40°C

Working pressure:

max. 3 bar

Flow rate:

min. 30 cm/sec.

Display: 2x 4 digit LCDs (12.4 / 7 mm high)

Interface: serial interface, direct connection to RS232 or USB interface of a PC via electrically isolated interface converter.

General Functions:

Min-/Max-value memory, Hold function, Auto-Off-Function, Low battery warning

Power supply: 9V-battery, type IEC 6F22 (included) as well as additional d.c. connector for external 10.5-12V direct voltage supply. (suitable power pack: GNG10/3000)

Power consumption: approx. 3 mA

Housing dimensions:

142 x 71 x 26 mm (H x W x D), impact-resistant ABS, Front side IP65, integrated pop-up clip for table top or suspended use.

Weight: approx. 300 g (incl. battery and probe)

Temperature compensation: automatic via temperature sensor integrated in electrode.

Air pressure compensation:

3610: enter current air pressure via keyboard

3630: automatic via integrated pressure sensor. Display of current air pressure.

Correction of salinity (3630): autom. salinity value can be set via keyboard from 0,0 ... 70,0

Calibration: 1-point calibration: extremely simple quick calibration in atmospheric air.

2-point calibration (GMH3630 only): first point at atmospheric air, second point at upper measuring range (with calibration set GKS3600).

Scope of supply: device incl. electrode, GWOK01 and KOH electrolyte



GOX 20

Device incl. oxygen probe

Specification:

Measuring range:

Temperature: 0.0 ... 40.0 °C
Oxygen: 0.0 ... 20.0 mg/l O₂

Resolution:

Temperature: 0.1 °C
Oxygen: 0.1 mg/l O₂

Accuracy: (at 25°C) ±1digit

Temperature: ±0.3°C (range 0-30°C)
Oxygen: ±2% of m.v. ±0.2 mg/l

Electrode:

active diaphragm type. Electrode-Ø front: approx. 12mm, length: approx. 170mm, connecting cable approx. 2 m permanently connected to device.

Response time:

95% in 10sec., depending on temperature approx. 3 years or more dependant on maintenance

Operation life:

max. 3 bar

Temperature compensation:

automatically via temperature sensor integrated in electrode

Calibration:

simple quick-calibration in atmospheric air

Display:

3½-digit LCD display, 13mm high

Working temperature:

0 to 50 °C

Storage temperature:

-5 to 70 °C

Power supply:

9V-battery type IEC 6F22

Power consumption:

max. 1 mA

Low battery warning:

automatic; "BAT"

Dimensions:

106 x 67 x 30 mm, ABS plastic housing

Weight:

approx. 250 g (ready for use)

Scope of supply:

device incl. electrode, GWOK01 and KOH electrolyte

Options (upcharges) / accessories:

- electrode with 10 m cable
- electrode with 30 m cable

GSKA 3600

protection cap for depth measuring

GWOK 01 spare diaphragm head

GKS 3600 calibration set (consisting of calibration device, 100 ml calibration solution, 10 ml catalytic solution, measuring pipette and measuring bottle)

GKN 3600 calibration refill set (consisting of 100ml calibration solution, 10ml catalytic solution, meas. pipette)

GAS 3600 Working set (consisting of 3 spare diaphragm heads and 100ml KOH-electrolyte)

KOH 100 Spare electrolyte 100 ml

GWO 3600

Spare electrode with 4 m cable

for add. accessories p.r.t.p. 56 - 58

Compact CO - measuring device

GCO 100



- 3 display units selectable (ppm, mg/m³ and % CO Hb)
- Freely adjustable alarm boundaries - integrated acoustic alarm
- Alert at exceeding the maximum concentration at work (MAK/AGW)
- Automatic zero point adjustment
- Max. value memory, hold function
- Interface for RS232- or USB-adapter
- Low power consumption (>1000 hours with normal 9V-battery)
- Battery or power adapter operation, Power-Off-function
- External switching module for 230V/10A (= GAM3000) directly pluggable
- Calibration protocol within scope of supply
- Integrated measuring element - 3 years warranty for the sensor

GCO 100

Specification:

Measuring principle:	electrochemical CO measuring cell		
Measuring range:	0 ... 1000 ppm CO-Concentration		
Display ranges:	0 ... 1000 ppm CO-Concentration 0 ... 1250 mg/m ³ CO-Concentration 0 ... 60.0 % CO Hb (estimation via exhaled breath gas)		
Resolution:	1 ppm, 1 mg/m ³ or 0.1 % CO Hb		
Measuring element:	integrated in device, measuring inlet at front plate, with inner thread for accessories screw in		
Life time:	>5 years at proper usage at air suggested test interval: every 6 months (depending on precision requirements)		
Accuracy:	(at range 0 ... 500 ppm), linearity: < ±5 % of measured value repeatability: < ±5 % of measured value		
Interference:	(extract)		
	Concentration (ppm)	residence time (min.)	display (ppm)
sulphur dioxide	50	600	<1
nitrogen dioxide	50	900	-1
nitric oxide	50	5	8
hydrogen	100	5	20
Carbon dioxide	5000	5	0
Display:	approx. 11 mm high, 4½-digit LC-display		
Pushbuttons:	3 membrane keys		
Nominal temperature:	25 °C		
Ambient condition:	-10 ... +50 °C, 15 ... 90 %RH (non-condensing)		
Storage temperature:	-10 ... +50 °C		
Power supply:	9V-battery, type IEC 6F22 (in scope of supply) as well as additional d.c. connector for external 10.5 - 12V direct voltage supply. (suitable power supply: GNG 10 / 3000)		
Power consumption:	<0.25 mA (>1000 operating hours)		
Housing:	impact-resistant ABS plastic housing, membrane keyboard, transparent panel. Front side IP65, integrated pop-up clip for table top or suspended use.		
Dimensions:	142 x 71 x 26 mm (H x W x D)		
Weight:	approx. 155 g		
Device functions:			
Hold function	by keypress the current measuring will be "frozen"		
Max value memory	the max. measured value will be stored		
Alarming	adjustable alarm rail, value depending alarm sound		
Power-Off-function	device will turn of after the set period off time (1-120 min. or deactiv), when no operating has taken.		

General:

Carbon monoxide (CO) is created by the combustion of carbon. Depending on the effectiveness of the combustion (oxygen supply) and the temperature of the combustion more or less CO gas is created. The gas is inflammable and highly toxic. It is invisible, tasteless, scentless and lighter than air.

Even smallest concentrations are dangerous for humans!

Therefore a directive exists in Germany, which limits the maximum concentration of CO gas at work (MAK / AGW) to 30 ppm

Application areas:

- Control of the air quality (e.g. at work place)
- Checking of heating systems, gas central-heating, fireplace
- Control of the air at maintenance work (tunnel, gas central-heating, ...)
- Detection of CO in the breath of smoker (% CO Hb)
- Cognition of CO poisoning i.e. at burnings (fire fighters, ...)

Price, accessories:

ESA 100 tube-adapter/flow diverter to screw in front plates.

ZOT 369 T-piece

GRV 100 non return valve

MSK 100 mouth peace of plastic

GAS 100 extension set for inhaled air control (consisting of ESA100, ZOT369, GRV 100 and 5x MSK100)

GZ-10 test gas cap GCO (for controlled flow with test gas)

GZ-02 gas bottle with 12l test gas: 30 ppm CO

GZ-03 gas bottle with 12l test gas: 300 ppm CO

GZ-04 gas valve unit MiniFlo for gas bottles with 12l

GB 9 V spare battery 9V / approx. 300mA/h, type IEC 6F22

GLI 9 V lithium battery 9V / approx. 1200mA/h

GKK 3000 case (275 x 229 x 83 mm) with punched lining

USB 3100 N interface converter to USB, elec. isolated

GAM 3000 switching module for 230VAC/10A

for additional accessories please refer to page 56 - 58

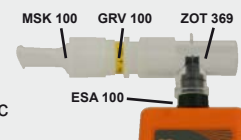

Measuring devices for volumetric flow and flow speed



Volumetric flow anemometer

GVA 0430

cpl. in case, incl. RS232 interface cable and software

- flow rate
- volumetric flow
- temperature

Application:

Ventilation and air conditioning technology, meteorology, water sport, air gliding etc.

Specification:

Meas. ranges:

Flow rate: 0,40 m/s to 30,00 m/s

Temperature: -10,0 ... +50,0°C

Resolution: 0,01 m/s resp. 0,1 °C

Accuracy: (at nominal temperature = 25°C)

Flow rate: ±2 % FS

Temperature: ±0,6 °C

Meas. probes: vane probe, 70mm rotor-Ø and precision-NTC

Meas. interval: 1 meas. / sec.

Display: 2-line LCD display, 37 x 42 mm

Working temperature: -10 to +50°C

Relative humidity: 0 to +95%r.h. (non-condensing)

Storage temperature: -10 to +50° C

Interface: serial interface RS232

Special function: averaging of 8 meas. points, averaging throughout meas. time, volumetric flow calculation, hold function, min./max. value memory

Power supply: 9V-batteries, type IEC 6F22 (included) or via external power supply

Operating time: 100 hours (with alkaline)

Low battery warning: display blinking

Automatic-Off-function: device switches off automatically after 20 minutes. Permanent mode possible.

Housing dimensions:

device: 183 x 76 x 45 mm (W x H x D),

probe: 155 x 75 x 42 mm (W x H x D),

Weight:

approx. 350g (meas. device and probe)

approx. 1.05kg (cpl. in case)

Accessories:

GNG 8901 power supply



Thermal anemometer

TA 888

complete set in case, incl. software

- high accuracy
- smallest and slow air flows measurable
- slimline telescopic probe

Applications:

Classic application of the TA 888 is flow measurement in ventilation ducts. Due to its high resolution of 0.01 m/s even smallest changes of the flow velocity can be easily and fast detected. The sensor's small dimensions ensure measurements yet in thin tubes and confined spaces.

Further applications are function and dirt checks of filters and exhaust ducts as well as measurements of room air velocity, e.g. for workspace checks.

Specifications:

Measuring range:

Flow: 0.10 m/s ... 25.00 m/s

Temperature: 0.0 ... +50.0°C

Resolution:

Flow: 0.01 m/s

Temperature: 0.1 °C

Accuracy:

Flow: (5 % + 0.1 m/s) FS

Temperature: ±1 °C

Display: LCD display

Meas. interval: approx. 0.8 s

Working temp.: 0 ... 50 °C

Relative hum.: 0 ... 80 % RH

Dimensions:

- **Housing:** 210 x 75 x 50 mm (H x W x D)

- **Telescopic probe:** extendable up to 1150 mm (incl. handle), Ø 10 mm

- **Cable:** 2 m

Wight: approx. 275 g (only measuring device)

approx. 1800 g (complete set in case)

Scope of supply: measuring device, battery, probe, case, power supply, USB cable, software

Accessories:

Calibration certificate (10 points) (without device)

DKD- certificate (10 points) (without device)

Phonometer



Phonometer

GSH 8922

with analog output, backlight display cpl. in case

General:

Compensation of the background-noise for measuring sound-sources in the foreground. Weighting of the sound level via two weighting-filters according to the IEC standard. Assignment of the max/min value during one measuring period.

Specification:

Measuring ranges: 30 - 130 dB (6 ranges)

30 - 80, 40 - 90, 50 - 100,

60 - 110, 70 - 120, 80 - 130 dB

manual or automatic selection of range

Resolution: 0,1 dB

Accuracy: ±1,5 dB

Norms: ANSI S1.4 and IEC 651 Typ 2

Frequency rate weighted: 31,5 Hz - 8 kHz

Evaluation weight filter: 2, selectable

Type A: evaluation of the spectrum in accordance with the perceptive faculties of the human ear.

(Sound insulation establishment, environmental analysis)

Type C: linear evaluation of spectrum

(sonic-analysis of engines or machines)

Weight of time factor: fast or slow

Microphone: 6mm Electret condenser mic.

Display: 3½-digit LCD-backlight display,

additionally quasi-analog bar graph

Analog output: AC: 0.707 Vrms, DC: 10mV DC / dB

Working temperature: 4 to +50°C

Relative humidity: 10 to +90 % RH

Storage temperature: -20 to +60° C

Interface: RS232, (2400BD8N1)

Power supply: 9V-batteries, type IEC 6F22

(included) or via external 9V power supply

Operating time: 20 hours (with alkaline)

Housing: 256 x 80 x 38 mm (H x W x D)

Weight: approx. 240g (meas. device)

Accessories:

GNG 8922 power supply

T-Logg 120 K SET/0-2V

incl. software, for mains-independent long-term recording system (p.r.t. page 79)

Rotation speed measuring device

via light and reflecting label or measuring tip;
velocity and length measurement via measuring wheel



rotaro 3

Rotation speed measuring device incl.

- Reflecting labels
- Measuring tip, hollow tip, measuring wheels (Ø 0.1 m and Ø 6")
- extension shaft
- Calibration certificate
- Case
- Battery

Applications:

The handheld tachometer rotaro 3 is useful at the installation and setup of plants and machinery as well as for service application, monitoring production processes or use at development laboratory. The rotaro 3 can measure rotary speed of for example motors, turbines, pumps as well as stirring devices, centrifuges and haulage installations, foil or textile manufacturing units, coil and transformer winding machines, machine tools, etc. Furthermore it can measure running speed and length of foils and band of all kind..

Specifications:

Measuring range:

rpm: 1.00 ... 99,999 min⁻¹ (optical measurement)
1 ... 19,999 min⁻¹ (mechanical measurement)

Velocity: Ø 0.1 m: 0.10 ... 1999 m/min
Ø 6": 0.10 ... 1524 m/min
(other units possible: m/sec, ft/min, in/min ...)
0 ... 99999 m / ft / in

Length: 0 ... 99999 m / ft / in

Accuracy:

rpm: ± 0.02% of m.v. (± 1 digit)

Meas. distance: max. 600 mm

Meas. principle: optical/ mechanical

Memory function: min- / max- value memory,
average and last value

Power-off: automatically after 30 s

Display: 5-digit LCD display with 10 mm height of digits
and floating point at range change

Power supply: 2 x AA battery or accumulator

Working temp.: 0 ... 50 °C

Storage temp.: -20 ... 70 °C

Housing: plastic ABS

Approval: CE

Dimensions: 175 x 60 x 28 mm (H x W x D)

Weight: 250 g

Rotation speed measuring device

via light and reflecting label



ecotach

Rotation speed measuring device incl.

- Reflecting labels
- Transportation slip case
- Battery

Applications:

The handheld tachometer ecotach is useful at the installation and setup of plants and machinery as well as for service application, monitoring production processes or use at development laboratory. The rotaro 3 can measure rotary speed of for example motors, turbines, pumps as well as stirring devices, centrifuges and haulage installations.

Specifications:

Measuring range: 1 ... 60.000 rpm

Accuracy: ± 0,02 % v. MW (± 1 Digit)

Meas. distance: max. 450 mm

Meas. principle: optical

Power-off: automatically after 30 s

Display: 5-digit LCD display for measuring value with
floating point, measuring unit, trigger signal,
low-battery warning

Power Supply: 2 x AA battery or accumulator

Working temp.: 0 ... 50 °C

Housing: plastic ABS

Approval: CE

Dimensions: 145 x 60 x 28 mm (H x W x D)

Weight: 147 g

Handheld instruments - Accessories

Device case:

- GKK 3000** with punched lining for 1 device of the GMH 3xxx-series (275 x 229 x 83 mm)
- GKK 3500** with punched lining for 1 device of the GMH 3xxx-series (394 x 294 x 106 mm)
- GKK 1420** with punched lining for 2 devices of the GMH 3xxx-series (450 x 360 x 123 mm)



GKK 1420



Einlage von GKK 3000



Einlage von GKK 3500



Universal case:

- ① **GKK 252** with foam lining for universal use (235 x 185 x 48 mm)
- ② **GKK 3100** with foam lining for universal use (275 x 229 x 83 mm)
- ③ **GKK 1100** with foam lining for universal use (340 x 275 x 83 mm)
- ④ **GKK 3600** with foam lining for universal use (394 x 294 x 106 mm)
- ⑤ **GKK 3700** with foam lining for universal use (450 x 360 x 123 mm)

Protection bag:

- ST-R1** Nappa leathern device protection bag with 1 round cut-out for sensor connection suitable for: GMH 3111, GMH 3151, GMH 3161-12, GMH 3181-12, GMH 3410, GMH 3430, GMH 3610, GMH 3630, GMH 3691, GMH 3710, GMH 3750, GMH 175
- ST-R2** Nappa leathern device protection bag with 2 round cut-outs for sensor connection suitable for: GMH 3156, GMH 3161-01, GMH 3161-07, GMH 3161-13, GMH 3181-01, GMH 3181-07, GMH 3181-13, GMH 3510, GMH 3530
- ST-N1** Nappa leathern device protection bag with 1 rectangular cut-out for sensor connection suitable for: GMH 3210, GMH 1150, GMH 1170
- ST-N2** Nappa leathern device protection bag with 2 rectangular cut-outs for sensor connection suitable for: GMH 3230, GMH 3250
- ST-RN** Nappa leathern device protection bag with 2 round cut-outs for sensor connection suitable for: GMH 3330, GMH 3350, GMH 3830, GMH 3850
- ST-KO** device protection bag suitable for: GTD 1100, GPB 2300, GPB 3300
- ST-KN** device protection bag with rectangular cut-out for sensor connection suitable for: GTH 1150, GTH 1170
- ST-KR** device protection bag with round cut-out (central) suitable for: GTH 175, GOX 20, GOX 100, GLF 100, GLF 100 RW
- ST-KF** device protection bag with punched-out slot for a sensor head suitable for: GFTH 95, GFTH 200, GFTB 100
- ST-KD** device protection bag with 2 round cut-outs suitable for: GDH 200 - 07, GDH 200 - 13, GDH 200 - 14, GMR 100



GMH 1300 with mounted device

Mount:

- GEH 1** Electrode retainer for measuring electrodes and probes suitable for our electrodes (pH/redox, conductivity, oxygen, ...) and temperature probes with plastic handle
- GMH 1300** Magnetic mount for hanging up devices with integrated suspension clip



Handheld instruments - Accessories



Interface:

USB 3100 N

Interface converter GMH 3xxx <=> PC, for electrically isolated connection of a GMH 3xxx to the USB-interface of your PCs. (Converter supplying from PC interface)

NEW

GRS 3100

Interface converter GMH 3xxx <=> PC for electrically isolated connection of a GMH 3xxx to the RS232-interface

GRS 3105

5-point interface converter GMH 3xxx <=> PC, connection of 5 GMH 3xxx to the RS232-interface of your PCs. (Converter supply achieved via permanently connected power supply) Device delivered with 9-pin DSub extension cable and 5 connection cables VEKA3105

VEKA 3105

Spare connection cable GMH 3xxx <=> GRS 3105

GSA 25S-9B

Connection adapter (25-pin Dsub-adapter <=> 9-pin Dsub-socket)

GSA 9S-25B

Connection adapter (9-pin Dsub-adapter <=> 25-pin Dsub-socket)

USB-Adapter

for connection of a RS232-interface converter to the USB-interface

Plug and Cable

MINIDIN 4S

Mini-DIN plug, 4-pin, with lock and for self installation

AAG2M

2 m analog output cable, 2x banana plug

Power supply:

GB 9 V

Spare battery 9V, type IEC 6F22

GLI 9 V

Lithium battery 9V, approx. 1200 mAh

GAK 9 V

NiMH accu 9V

GLG 1300

Charger for charging two 9V accus at the same time

GNG 09

Plug-in power supply (220 / 240 V, 50 / 60 Hz), output voltage: 12 V / 300 mA, suitable for devices with 2.5 mm jack connector

GNG 10

Plug-in power supply (220 / 240 V, 50 / 60 Hz), output voltage: 10.5 V / 10 mA, suitable for devices with 2.5 mm jack connector (e.g. for devices of the series GDH ...)

GNG 10 / 3000

Plug-in power supply (220 / 240 V, 50 / 60 Hz), output voltage: 10.5 V / 10 mA, suitable for devices with power supply socket (e.g. for devices of the series GMH ...)

GNG 8901

Plug-in power supply (220 / 240V, 50 / 60 Hz), output voltage: 9 V / 500 mA, suitable for devices with DC device socket 5.4 / 2.1 (suitable for GVA 0430)

GNG 8922

Plug-in power supply (220 / 240 V, 50 / 60 Hz), output voltage: 9 V / 500 mA, suitable for devices with DC device socket 3.5 / 1.2 (suitable for GSH 8922)



Switching modules:

GAM 3000

Switching module for the GMH3xxx-series

The GAM 3000 is an alarm or control output for the devices of the GMH3xxx-series with alarm output function. The GAM 3000 is controlled via the serial interface of the GMH3xxx. The setting of the alarm/switching limits are carried out the GMH3xxx as usual. You can choose between 2 different switching modes:

- **Alarm output:** Relay switches when the measuring value is no longer within the min./max. alarm limit values or an error state occurs at the set channel.

- **Control output:** In this case the min./max. values are not used as alarm points but as on/off switching points. In case of an error state the relay switches in its preferred state "off".

The desired switching function can be selected via an externally accessible miniature switch.

Power supply: 220 / 240 V, 50 / 60 Hz

Switching output: controlled power socket, selector switch to choose switching state normally-open or normally-closed

Switching power: 10 A (ohmic load)

GMH-connection: GMH3xxx interface and supply (integrated power supply 10.5V/10mA) via 1 m cable each, permanently connected to GAM 3000.

Dimensions: (controller) 112 x 71 x 48 mm (H x W x D)

Hand-held instruments - software

Operation for GMH 3xxx / GMH 5xxx - logger device

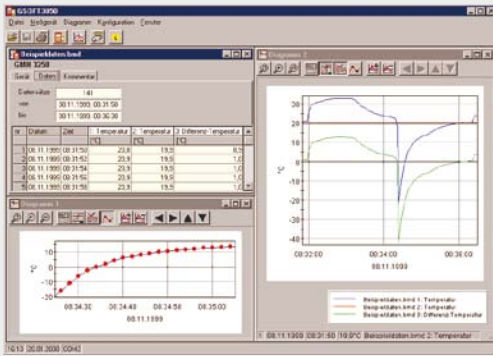

GSOFT 3050

Windows-software for the setting, data read-out and printing of all data stored by devices of the GMH3xxx- and GMH5xxx-series with logger.

General advice:

With GSOFT3050 you are able to operate the logger function of the GMH3000- and GMH5000 hand-held series. The logger recordings can be started, stopped, read in and displayed. It is also possible to operate several instruments simultaneously and to display their data in mutual diagrams. Data will be read via the serial interfaces 'COM 1' - 'COM 255' of your PC and an interface adapter (GRS3100, GRS3105 or USB3100).

Software is multilingual, the language can be selected simply in the programme. Executable with Windows 98, Me, NT, 2000, XP, Vista and 7.

The GSOFT3050 offers, among others, the following functions:

- **Display of the GMH-information**
- **Setting of the alarm function** for GMH3xxx devices.
- **Operation of the logger function**
simple selection of the logger function (cyclic or manual), setting of cycle time, logger recording start and stop, read-out of logger data.
- **Diagram display of logger data**
The logger data can be displayed in form of a diagram. It is possible to display various measuring sequences in one diagram. The diagram offers the following functions:
 - display including real-time axis, zooming of display view
 - display of legend can be switched on/off
 - marking of measuring points can be switched on/off
 - a new/existing measuring sequence can be added/deleted at any time
- **Logger data print-out**
Data can be printed as tables (complete measuring sequence or limited area) or as diagram (in accordance with the current diagram window).
- **Memorizing of logger data**
The logger data can be saved in files and, therefore, called up again at any given time without a connected device.
- **Export of logger data to ASCII (text) file format**
- **Memorizing of windows**
Data and diagram windows can be placed at any desired. The setup of the windows can be stored as 'view'.

GMH 3000.DLL

Windows-functional library for interface communication.

To integrate all GMH 3xxx device functions in own Windows programm, i.e. LabView.

Long-time monitoring - Recording - Monitoring



EBS 20M

(20-Channel Measurement Data Logging)

EBS 60M

(60-Channel Measurement Data Logging)

This software makes up a low-price and comfortable multi-channel acquisition program for measuring data. The program is suitable for recording, monitoring, visualization and documentation.

Field of application:

- On-site recording
- Process and system control, monitoring of climate and buildings
- Real time monitoring of measuring data
i.e for data evaluation and logging for cost listings, overview of consumption, optimisation of processes, and other statistics

Highlight:

- Simultaneous use of several serial interfaces
- Simultaneous use of different serial converters
- Quick and easy installation
- Freely scaleable diagrams and alarm limits
- Visualization of actual measurements values
- Trusted data storage via SQL database
- Data export

Moduls:

- Large-digit display
- Diagram display
- Table display
- Visualization of alarm limits
- Visualization of all recorded datas in one diagram

Measuring Cycle:

depending on the number of channels: 500ms to 10s

System Requirements:

Windows XP, Windows Vista, Windows 7

Simultaneous use of different serial Bus-Systems: EASYBus, GMH handheld devices, GDUSB 1000

ProfiLab-Expert 4.0

The software ProfiLab-Expert allows you to develop your own digital or analog measuring technology requirement.

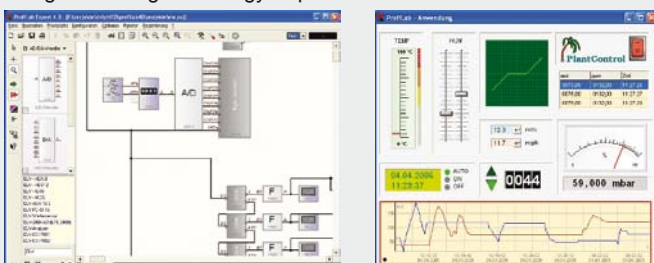

It doesn't matter if you want to create analog measurements or digital controls - you can realize it all. And for all this you don't have to write a single program-line!

ProfiLab-Expert supports our devices of the GMH3xxx-Serie with serial interface, GCO100, GFTB100/GRS, as well as all EASYBus-devices. Every device will be displayed in your project like a normal component. You only have to connect his inputs and outputs.

Compiler inclusive !

ProfiLab-Expert is equipped with an integrated compiler. The compiler can create executable files for stand-alone applications that run on systems without ProfiLab-Expert.

The distribution of these compiled applications is unlimited, so ProfiLab-Expert become a complete and professional developers system.

Software executable with: Windows 98, Me, NT, 2000 and XP.

Display / Controller

	Dimensions					Measuring input							Page
	24 x 48	48 x 96	33 x 75	48 x 48	Special size	Normalized signal	Temperature (Pt100 / Pt1000)	Temperature (Thermocouples)	Temperature (NTC, PTC)	Frequency	Universal input	Ex - Protection	

DISPLAY

GIA .. N	✓					✓							60
GIA .. N - ex	✓					✓						✓	60
GIA 2448	✓					✓							61
GTH2448/1	✓						✓						61
GTH2448/2 ../3	✓						✓						61
GTH2428/4 ../5	✓						✓						61
GTH 83 EG		✓						✓					64
GTH1150 EG		✓						✓					64
GIA 2000		✓				✓	✓	✓		✓	✓		65
GIA 0420 VO(T)					✓	✓							72
GIA 0420 VOT - ex					✓	✓						✓	72
GIA 0420 WKT					✓	✓							72
GIA 0420 WKT - ex					✓	✓						✓	72

CONTROLLER

GIA 20 EB	✓										✓		62
GIR 230 ..	✓					✓	✓	✓	✓	✓			63
GIR 230 DIF	✓					✓	✓		✓				63
GIR 2002		✓				✓	✓	✓		✓	✓		66
GIR 2002 PID		✓				✓	✓	✓		✓	✓		66
GIR 2002 .. SW		✓				✓	✓	✓		✓	✓		68
GIR 2002 NS / DIF ..		✓				✓							69
GIR 2000 Pt ..		✓					✓						69
R 38			✓				✓	✓	✓				70
K 31 / K 32			✓			✓	✓	✓	✓				70
TLK 43				✓		✓	✓	✓	✓		✓		71
K 48				✓		✓	✓	✓	✓				71
GRA .. VO					✓	✓							73
GRA .. WK					✓	✓							73



µP-display with freely adjustable scale



GIA 0420 N / GIA 010 N



GIA 0420 N

Display without auxiliary energy, input 4-20 mA

GIA 010 N

Display, input 0-10 V

GIA 0420 N - ex



Display, input 4-20 mA, with EX-protection for all potentially explosive atmospheres

Ex qualification: Ex II 2G Ex ia/ib IIC/IIB T4

(Further Information please refer to our Homepage www.greisinger.de)

GIA 010 N - ex



Display, input 0-10 V, with EX-protection for all potentially explosive atmospheres

Ex qualification: Ex II 2G Ex ia/ib IIC/IIB T4

(Further Information please refer to our Homepage www.greisinger.de)

- time-saving on-site scaling without any additional auxiliary modules
- simple device identification by means of insertion film.
- optimum operational reliability due to integrated self-diagnosis function and watchdog system.
- large display range from -1999 to +9999 digits
- high accuracy combined with minimum temperature drift due to integrated self-calibration
- smallest housing dimensions possible
- monitoring of probe damage, probe short-circuit, values no longer within measuring range.
- software filter for clear display even in case of encoder signal interference (can be switched on and off)

Specification:

	GIA 0420 N ..	GIA 010 N ..
Input signal:	4 ... 20 mA 2-wire	0 ... 10 V 3-wire
Voltage load:	approx. 3,5 V	-
Input resistance:	-	approx. 100 kOhm
max. input:	25 mA	15 V
Power supply:	-	12 - 28 V DC
Power consumption:	aus Stromschleife	< 10 mA
Display:	LCD display, approx. 10 mm high	
Display range:	-1999 bis +9999	
Decimal point:	any position selectable	
Scaling:	scale freely adjustable via 3 keys at the back side of the unit	
Accuracy:	< 0,2% FS ±1 Digit (at 25 °C)	
Temperature drift:	< 100 ppm / K	
Meas. rate:	approx. 5 measurements / sec.	
Filter:	adjustable: 0,1 ... 2,0; off	
Storage:	min- / max-value memory	
Switching output:	electrically isolated open collector	
Switching capacity:	28V DC / 50 mA	
Working temp.:	0 to 50 °C	
Storage temp.:	-20 to 70 °C	
Electric connection:		
GIA 0420 N ..	2 x 2-pin screw-type/plug-in terminal max. terminal range up to 1.5 mm ²	
GIA 010 N ..	1 x 2-pin., 1 x 3-in. screw-type/plug-in terminal, max. terminal range up to 1.5 mm ²	
Housing:	fibre-reinforced Noryl	
Front screen:	polycarbonate	
Dimensions:	24 x 48 mm (H x W, front dimensions)	
panel cutout:	21.7 ^{+0.5} x 45 ^{+0.5} mm (H x W)	
mounting depth:	approx. 65 mm incl. terminal	
Protection rating:	IP54 (IP65 by means of additional optional silicone O-rings, GGD2448SET)	



Universal LowCost-LED-Display for Standard Signals and Temperature

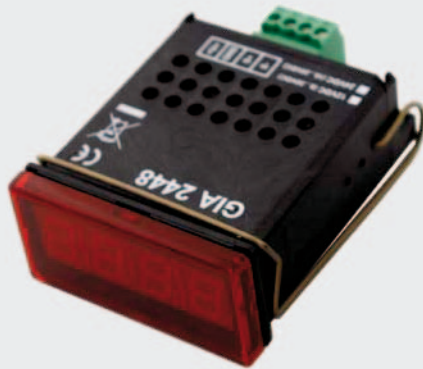

Digital display
for standard signals

GIA 2448 (for self-adjustment)

GIA 2448 WE ¹⁾
(settings and calibrations by our works)

1) Please specify as follows upon order: Input signal, scaling (lower and upper limits), decimal point and supply voltage.

(Order to read e.g. GIA2448WE: 4-20mA, 4mA=-50.0, 20mA = 100.0, 12VDC)

Specification

Meas. ranges:	0-20 V, 0-10 V, 0-2 V, 0-1 V, 0-200 mV, 0-20 mA and 4-20 mA. (select via soldering jumpers)
Display range:	-1999 ... +1999 digit (adjustable via soldering jumpers and potentiometer)
Decimal point:	any position by means of soldering jumpers (soldering jumpers accessible after removal of front panel)
Accuracy:	±0.2% ±1 digit (at nominal temperature = 25°C)
Scan rate:	approx. 3 measurements / sec.
Display:	3½-digit, red 10 mm high LED display
Working temperature:	0 to 50 °C (permissible ambient temperature)
Relative humidity:	5 to 95 %RH (non-condensing)
Storage temperature:	-20 to 70 °C
Voltage supply:	8 - 20 V DC or 18 - 29 V DC (Standard) (set via soldering jumper)
Current supply:	max. 20 mA
Housing:	glass fibre reinforced Noryl, front panel PC.
Dimensions:	24 x 48 mm (H x W) (front frame)
Mounting depth:	approx. 65 mm (incl. screw-type/plug-in terminal)
Panel mounting:	with VA-spring clamp. allowed panel thicknesses from 1 to approx. 10 mm
Panel cut-out:	21.7 ^{+0.5} x 45 ^{+0.5} mm (H x W).
Connection terminal:	4-pin screw-type/plug-in terminal for wire cross sections from 0.14 to 1.5 mm ²
Noise immunity (EMC):	meets EN50081-1 and EN50082-2 requirements, additional fault: <1%
IP rating:	front side IP54 (with optional O-rings IP65).

Option upcharge

- **VAC** voltage supply 8-20 V AC or 18 - 29 V AC set via soldering jumper

Accessories

- GGD 2448 SET** optional O-rings for IP65 (2 pieces)
- GNG 220/2-12V** power supply for GIA 2448 and GTH 2448 (Input: 230 V_{AC} ; output: 2 x 12 V_{DC} regulated, 30 mA each)
- GNG 12/24** power supply (Input: 12 V_{DC} ; output: 24 V_{DC} electrically isolated)
- GNG 24/24** power supply (Input: 24 V_{DC} ; output: 24 V_{DC} electrically isolated)

for additional accessories, transmitter, probes p.r.t.p. 74-75, 96-119, 121-135



Digital thermometer
for NiCr-Ni, Pt100 or Pt1000

GTH 2448/1 (NiCr-Ni)

GTH 2448/2 (Pt100, 1°C)

GTH 2448/3 (Pt100, 0.1°C)

GTH 2448/4 (Pt1000, 1°C)

GTH 2448/5 (Pt1000, 0.1°C)

Specification

Measuring ranges, Resolution:	
GTH 2448/1:	- 50 ... +1150 °C (NiCr-Ni)
GTH 2448/2:	-200 ... + 650 °C (Pt100, 2-wire)
GTH 2448/3:	-60,0 ... +199.9 °C (Pt100, 2-wire)
GTH 2448/4:	-200 ... + 650 °C (Pt1000, 2-wire)
GTH 2448/5:	-60,0 ... +199.9 °C (Pt1000, 2-wire)
Accuracy: (at nominal temperature = 25°C)	
NiCr-Ni:	±1% ±1 digit (from -20...+550°C and 920...1150°C) ±1.5% ±1 digit (from 550... 920°C)
Pt100, Pt1000:	±0.5°C ±1 digit or ±1°C ±1 digit
Offset compensation: (only for Pt100 and Pt1000) The zero point offset of the sensor (e.g. due to long cables) can be compensated for by means of the spindle trimmer on the backside of the device.	
Display:	3½-digit, red 10 mm high LED display
Scan rate:	approx. 3 measurements / sec.
Working temperature:	0 to 50 °C (permissible ambient temperature)
Relative humidity:	5 to 95 %RH (non-condensing)
Storage temperature:	-20 to 70 °C
Voltage supply:	8 - 20 V DC or 18 - 29 V DC (Standard) (set via soldering jumper)
Current supply:	max. 20 mA
Housing:	glass fibre reinforced Noryl, front panel PC.
Dimensions:	24 x 48 mm (H x W) (front frame)
Mounting depth:	approx. 65 mm (incl. screw-type/plug-in terminal)
Panel mounting:	with VA-spring clamp. allowed panel thicknesses from 1 to approx. 10 mm
Panel cut-out:	21.7 ^{+0.5} x 45 ^{+0.5} mm (H x W).
Connection terminal:	4-pin screw-type/plug-in terminal for wire cross sections from 0.14 bis 1.5 mm ²
IP rating:	front side IP54 (with optional O-rings IP65).

System solution - complete packages:

KFZ 2000

Exhaust gas temperature set for measurement of exhaust gas temperatures up to 1000 °C in motor vehicles. The Set consists of:



- **GTH 2448/1** NiCr-Ni thermometer with additional over-voltage protection
- **GTF 101-5/30150 / NIMONIC** temperature probe with jacket material: Nimonic 75 (view p.r.t. page 127) Cable length = 3 m (extended cable against upcharge available)
- **GKV 4** clamping ring screw connection (p.r.t. p. 134)

Universal Display and Regulating Device



GIA 20 EB

easy operability - high accuracy - economy-price

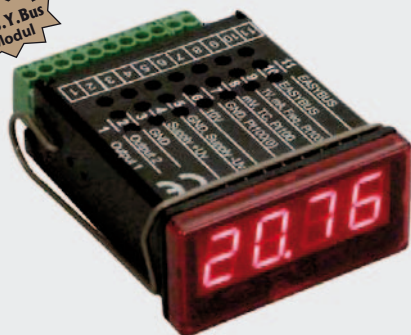

Option: Frontpanel with push buttons
(frontpanel without buttons included in delivery)

- Universal inputs for normalized signals, frequency, Pt100, Pt1000 and thermocouples
- 2 integrated switching outputs
- Configurable as display or controller (5 switching functions)
- Quick regulating and controlling stage
- extensive self-monitoring and diagnostic system
- Serial interface (max. 240 devices can be combined)
- Limit functions, digital filter, min-/max value memory
- Alarm delay selectable

Specification

Measuring input: universal input for

- **Normalized signal:** 4-20 mA, 0-20 mA, 0-1 V, 0-2 V, 0-10 V, 0-50 mV
- **Resistance thermometer:** Pt100 (3-wire), Pt1000 (2-wire)
- **Thermocouples:** types J, K, N, S, T
- **Frequency, Rotational speed:** TTL-signal, switching contact
- **Counter up / down:** TTL-signal, switching contact
- **Serial interface**

Measuring rate: approx. 100 meas. / sec. (for norm. signal) resp. approx. 4 meas. / sec. (for temperature and frequency)

Measuring resp. display ranges, resolution:

Temperature: (display unit selectable: °C or °F)

Pt100: -200 ... +850°C or -50.0 ... +200.0°C

Pt1000: -200 ... +850°C

type J: -170 ... +950°C **type K:** -270 ... +1350°C

type N: -270 ... +1300°C **type S:** -50 ... +1750°C

type T: -270 ... +400°C

Norm. signals: -1999 ... 9999 digit, scale freely adjustable

- **recommended range:** ≤ 2000 digit

Frequency: 0.000 Hz ... 10 kHz, display freely scaleable

Rotational speed: 0.000 U/min ... 9999 U/min, selectable prescaler: 1-1000

Counter up/down: *countvalue remains on power loss*
0 ... 9999 (10 Mio. with prescaler), pulse frequency: ≤ 10kHz, selectable prescaler: 1-1000

Serial interface: Displaying and controlling from values coming via the serial interface.

Accuracy: (at nominal temperature = 25°C)

- **Norm. signal:** < 0.2 % f.s. ±1digit (at 0-50mV: < 0.3% f.s. ±1digit)
- **Resistance thermometer:** < 0.5 % f.s. ±1digit
- **Thermocouples:** < 0.3 % f.s. ±1digit (at type S: < 0.5% f.s. ±1digit)
- **Point of comparison:** ± 1 °C
- **Frequency, rotational speed, counter:** < 0.1 % f.s. ±1digit

Outputs: 2 switching outputs, not electrically isolated

Switching behavior: Low-Side, High-Side or Push-Pull (selectable)

Connection data: Low-Side: 28V/1A; High-Side: Ub/200mA

Controller state: 2-point, 3-point, 2-point with alarm, min/max alarm to 1 output, min/max alarm to 2 outputs

Swirching point, hysteresis: freely adjustable

Response time: ≤ 20 msec. at normalized signals
≤ 0.3 sec. at temperature and frequency

Display: approx. 10 mm high, 4-digit red LED-display

Service: with 3 push-buttons (after disassembly of the frontpanel).

Option: FS3T, frontpanel with 3 push-buttons for comfortable configuration.

Trouble-free replacement is possible (refer accessories)

Min-/max-value memory: the max- and min value will be stored.

Interface: serial interface, elect. isolated, EASYBus compatible

Miscellaneous: permanent self-monitoring, digital filter function, measuring range boundary (limit)

Voltage supply: 9 to 28 V DC (standard)

Option: elec. insulated voltage supply 11-14V or 22-27V

Power consumption: max. 30 mA (without outputs)

Nominal temperature: 25 °C

Operating temperature: -20 to +50 °C

Relative humidity: 0 to 80 %RH (non condensing)

Storage temperature: -30 to +70 °C

Housing: glass fibre reinforced Noryl, front panel PC

Dimensions: 24 x 48 mm (front frame).

Mounting depth: approx. 65 mm (incl. screw-type/plug-in terminal)

Panel mounting: with VA-spring clamp.

Allowed panel thicknesses from 1 to approx. 10 mm.

Panel cut-out: 21.7+0.5 x 45+0.5 mm (H x W)

Connection terminal: screw-type/plug-in terminal: 2-pin for interface and 9-pin for outer connections.

For wire cross sections from 0.14 to 1.5 mm².

IP rating: front side IP54, with optional r-rings IP65

Noise immunity (EMC): EN61326 (appendix A, class B)

Options (upon upcharge)

- **IS12** type with insulated power supply: 11-14V

- **IS24** type with insulated power supply: 22-27V

Special design types

GIA 20 EB / PK

Universal display and regulating device with individual programmable linearization characteristic

Even heavily bent sensor characteristics/value curves can be approximated by a straightened curve with **30** freely programmable linearization points.

The adjustment to the measurement is done via the integrated interface with the (gratis) configuration software. Therefore only the input values (in mA, V, Ω or Hz) and the corresponding displayed values have to be entered.

For detailed information please refer to our homepage www.greisinger.de

Accessories

GGD2448SET O-rings for device mountig IP65 (2 pieces)

FS3T Frontpanel with 3 push-buttons

For comfortable configuration, for adjustments at variable switching points, calling of min- and max-values etc.

GNR10 Power supply and relay module for one GIA20EB (p.r.t. page 75)

(Input: 230VAC, Power supply for device + transducer, 2 relay outputs)

Temperature probes

p.r.t. page 121 - 135

Transducer

p.r.t. page 96 - 119

for other accessories p.r.t. page 74/75, 93/94

The Displaying and Regulating Device for 230 V

Front
24 x 48



GIR 230 ...

- 5 input executions for choice:
 - normalized signal: 4-20mA, 0-20mA, 0-10V
 - resistor: Pt100 (3-wire), Pt1000 (2-wire)
 - thermo couple: type J, K, N, S, T and 0-50mV
 - frequency
 - NTC
- **2 relay outputs** and 1 switching output NPN (GIR 230 NTC: 1 relay output)
- configurable as display or controller (5 switching functions)
- extensive self-monitoring and diagnostic system
- min/max value memory, limit functions, digital filter

GIR 230 NS (normalized signal input)

Controller with meas. input for normalized signal (4-20 mA, 0-20 mA, 0-10 V)

GIR 230 Pt (resistance input)

Controller with measuring input for Pt100 and Pt1000

GIR 230 TC (thermo couple input)

Controller with meas. input for thermo couple and 0-50 mV

GIR 230 FR (frequency input)

Controller with measuring input for frequency

GIR 230 NTC

Controller with measuring input for NTC and only 1 relay output

Version

GIR 230 NS:

Measuring input: 4-20mA, 0-20mA, 0-10V
Display range: -1999 ... 9999 digit, scale freely adjustable
recommended range: ≤ 2000 digit
Accuracy: < 0.2 % f.s. ±1 digit (at nominal temperature = 25°C)
Measuring rate: approx. 100 measurings / sec.

GIR 230 Pt:

Measuring input: Pt100 (3-wire), Pt1000 (2-wire)
Measuring ranges, resolution:
Pt100: -200 ... +850°C resp. -50.0 ... +200.0°C
Pt1000: -200 ... +850°C
Accuracy: < 0.5 % f.s. ±1 digit (at nominal temperature = 25°C)
Measuring rate: approx. 4 measurings / sec.

GIR 230 TC:

Measuring input: types J, K, N, S, T and 0-50 mV
Measuring ranges, resolution:
type J: -170 ... +950°C **type K:** -270 ... +1350°C
type N: -270 ... +1300°C **type S:** -50 ... +1750°C
type T: -270 ... +400°C
Accuracy: < 0.3 % f.s. ±1 digit (type S: < 0.5 % f.s. ±1 digit) (at 25°C)
Point of comparison: ± 1 °C
Measuring rate: approx. 4 measurings / sec.

GIR 230 FR:

Measuring input: frequency (TTL-signal)
Display range: -1999 ... 9999 digit, freely scaleable
Accuracy: < 0.2 % f.s. ±1 digit (at nominal temperature = 25°C)
Frequency measuring: 0.000 Hz ... 10 kHz
Rotational speed: 0.000 U/min ... 9999 U/min, selectable prescaler (1-1000)
Counter up/down: 0 ... 9999 (~10.000.000 with prescaler)

GIR 230 NTC:

Measuring input: NTC (2-wire)
Measuring ranges: -40.0 ... +120.0°C
Accuracy: < 0.5 % f.s. ±1digit (at nominal temperature = 25°C)
Measuring rate: approx. 4 measurings / sec.

Suitable temperature probes

Temperature probes (Pt100/1000) p.r.t. page 121/122, 129-133

Temperature probes (type K, S, N) p.r.t. page 123/127, 129-133

GTF230S ntc-temperature probe, -40 ... +120°C
 sensor sleeve made of st. steel, Ø 5 x 50 mm, approx. 1m silicone-cable
Option: longer probe cable (silicone) upcharge each m:

GIR 230 Pt1000 / DIF

Difference controller with 2 measuring inputs for Pt1000

GIR 230 NTC / DIF

Difference controller with 2 measuring inputs for NTC

GIR 230 NS / DIF - ...

Difference controller with 2 measuring inputs for 4-20 mA, 0-20 mA or 0-10 V

Version

GIR 230 Pt1000 / DIF, GIR 230 NTC / DIF:

Measuring inputs: 2 x Pt1000 (2-wire) resp. 2 x NTC
Meas. ranges, resolution: **Pt1000:** -200 ... +850°C, 1°C
NTC: -40.0 ... +120.0°C, 0.1°C

Display: difference temperature sensor1 - sensor2
Accuracy: < 0.5 % f.s. ±1digit (at nominal temperature = 25°C)
Measuring rate: approx. 4 measurings / sec.

GIR 230 NS / DIF - 420mA, ... - 020mA, ... - 010V:

Measuring inputs: (2 x) 4-20 mA, (2 x) 0-20 mA or (2 x) 0-10 V
specify required input signals by order!
Display range: -1999 ... 9999 digit, scale freely adjustable
recommended range: ≤ 2000 digit
Accuracy: < 0.2 % f.s. ±1 digit (at nominal temperature = 25°C)
Measuring rate: approx. 100 measurings / sec.

General Specifications

Outputs:

Relay output: 2 (1) closing contacts (GIR 230 NTC: 1 relay output), 230V~ switching, switching power: 5A, 230VAC
Alarm output: NPN, open collector, switching power: 30mA, max. 28V
Controller states: 2-point, 3-point*, 2-point with alarm, min/max alarm to 1 output, min/max alarm to 2 outputs* (* = not available at GIR230NTC)
Switching points, hysteresis, alarm points: freely selectable

Others:

Display: approx. 10 mm high, 4-digit red LED-display
Operating conditions: -20 to +50 °C, 0 to 80 %RH (non condensing)
Power supply: 230V, 50/60Hz, approx. 2 VA
Housing: glass fibre reinforced Noryl, front panel PC
 Dimensions: 24 x 48 mm (front frame).
 Mounting depth: approx. 65 mm (incl. screw-type/plug-in terminal)
Panel mounting: with VA-spring clamp.
 Allowed panel thicknesses from 1 to approx. 10 mm.
 Panel cut-out: 21.7+0.5 x 45+0.5 mm (H x W)
Connection terminal: screw-type/plug-in terminal:
 4-pin (...NTC: 3-pin) for power supply and relay outputs and 4-pin (...NTC: 3-pin) for measuring input and alarm output
 For wire cross selections from 0.14 to 1.5 mm².
IP rating: front side IP54 (IP65 upon request)
Noise immunity (EMC): EN61326 (appendix A, class B)

Option (upcharge)

- **24V** GIR with power supply 12 - 28 V DC
Outputs: 2 (1) relay outputs, +Ub switching

Accessories

GGD2448SET O-rings for device mounting IP65 (2 pieces)

Transducer p.r.t. page 96 - 119

for other accessories p.r.t. page 74/75



Panel Instrument for Temperature



Digital thermometer
for silicon sensors KTY 83

GTH 83 EG without sensor

-50,0 up to +150,0 °C

Specification

Measuring range: -50.0 to 150.0 °C
Resolution: 0.1 °C
Sensor: KTY 83-110 (please order separately),
Additional zero point offset possible via spindle trimmer at back side of device.

Accuracy (display device): (at nominal temperature = 25°C)
 $\leq 0.5^\circ\text{C} \pm 1$ digit (from -10 to +120°C)

Display: approx. 13mm high, 3½-digit, red LED-display

Scan rate: approx. 3 measurements / sec.

Working temperature: 0 to 50 °C

Relative humidity: 0 to 80 %RH (non-condensing)

Storage temperature: -20 to 70 °C

Power supply: 230V 50/60Hz

Option: 12/24/115V AC
 12/24V DC

Housing: standard rack-type housing, 48 x 96 x 100mm (H x W x D)

IP rating: front side IP54 (with optional O-rings IP65).

Panel cutout: 43 x 90.5 (H x W)

Connection terminals: screw-type/plug-in terminals,
 max. terminal range 1.5 mm²

Noise immunity (EMC):

The GTH83EG is conforming to the regulations determined by the Council for the Approximation of the Legislation amongst the Member Countries concerning EMC (2004/108/EG).

The device meets EN50081-1 and EN50082-2 requirements.

additional error: <1%

Options (against upcharge)

12VDC: Power supply: 12VDC

24VDC: Power supply: 24VDC

12VAC: Power supply: 12VAC

24VAC: Power supply: 24VAC

115VAC: Power supply: 115VAC

Accessories

GGD 4896 additional sealing for panel mounting IP65

Suitable sensors

GMF 11/180 immersion probe

GMF 30/180 immersion, air probe

GMF 15/180 screw-type probe

Other probes or custom-built sensors available. (p.r.t. page 128).



Digital thermometer
for thermocouples NiCr-Ni (type "K")

GTH 1150 EG without sensor

-50 up to +1150 °C

Specification

Measuring range: -50 to 1150 °C

Resolution: 1 °C

Sensor: NiCr-Ni (type K) (please order separately)
Additional zero point offset possible via spindle trimmer at back side of device.

Accuracy (display device): (at nominal temperature = 25°C)
 $< 1\% \pm 1$ digit (from -20 to +550°C and 920 up to 1150°C);
 $< 1.5\% \pm 1$ digit (from 550 to 920°C),
 from -50 to -20°C acc. to correction table

Display: approx. 13mm high, 3½-digit, red LED-display

Scan rate: approx. 3 measurements / sec.

Working temperature: 0 to 50 °C

Relative humidity: 0 to 80 %RH (non-condensing)

Storage temperature: -20 to 70 °C

Power supply: 230V 50/60Hz

Option: 12/24/115V AC
 12/24V DC

Housing: standard rack-type housing, 48 x 96 x 100mm (H x W x D)

IP rating: front side IP54 (with optional O-rings IP65).

Panel cutout: 43 x 90.5 (H x W)

Conn. terminals: screw-type/plug-in terminals,
 max. terminal range 1.5 mm²

Noise immunity (EMC):

The GTH1150EG is conforming to the regulations determined by the Council for the Approximation of the Legislation amongst the Member Countries concerning EMC (2004/108/EG). The device meets EN50081-1 and EN50082-1.

additional error: <1%

Options (against upcharge)

12VDC: Power supply: 12VDC

24VDC: Power supply: 24VDC

12VAC: Power supply: 12VAC

24VAC: Power supply: 24VAC

115VAC: Power supply: 115VAC

Accessories

GGD 4896 additional sealing for panel mounting IP65

Suitable sensors

Order all NiCr-Ni (type "K") - sensors without plug but with ferrule.
 (p.r.t. pages 123 - 127, 132 - 133)

Custom-built sensors available. (p.r.t. pages 130 and 131).



Universal Displaying Device

GIA 2000

easy operability - high accuracy - economic price

Temperature display, pressure control, tachometer, flow meter, etc.



- Universal inputs for normalized signals, frequency, Pt100, Pt1000 and thermocouples, freely adjustable
- integrated isolated power supply for meas. transducer (24V / 22mA)
- extensive self-monitoring and diagnostic system
- Serial interface - EASYBus (max. 240 devices can be combined)
- Limit functions, digital filter, min-/max value memory

Specification

Measuring input: universal input (freely adjustable) for
 - **Normalized signal:** 4-20mA, 0-20mA, 0-1V, 0-2V, 0-10V, 0-50mV
 - **Resistance thermometer:** Pt100 (3-wire), Pt1000 (2-wire)
 - **Thermocouples:** types J, K, N, S, T
 - **Frequency:** TTL-signal, switching contact
 - **Flow, Rotational speed:** TTL-signal, switching contact
 - **Counter up / down:** TTL-signal, switching contact
 - **Serial interface**

Measuring rate: approx. 100 meas. / sec. (for norm. signal and frequency) resp. approx. 4 meas. / sec. (for temperature)

Measuring resp. display ranges, resolution:

Temperature: (display unit selectable: °C or °F)
Pt100: -200 ... + 850°C or - 50.0 ... +200.0°C
Pt1000: -200 ... + 850°C
type J: -170 ... + 950°C or - 70.0 ... +300.0°C
type K: -270 ... +1372°C or - 70.0 ... +250.0°C
type N: -270 ... +1350°C or -100.0 ... +300.0°C
type S: - 50 ... +1750°C
type T: -270 ... + 400°C or - 70.0 ... +200.0°C

Norm. signals: -1999 ... 9999 digit, scale freely adjustable
 - **recommended range:** ≤ 2000 digit

Frequency: 0.000 Hz ... 10 kHz, display freely scaleable

Rotational speed: 0.000 ... 9999 U/min, selectable prescaler: 1-1000

Flow: 0 ... 9999 l/s, 0 ... 9999 l/min, 0 ... 9999 l/h

Counter up/down: counter value remains on power loss
 0 ... 9999 (10 Mio. with prescaler),
 pulse frequency: ≤ 10kHz

Serial interface: Displaying and controlling from values coming via the serial interface.

Accuracy: (at nominal temperature = 25°C)

- **Norm. signal:** < 0.2 % f.s. ±1digit (at 0-50mV: < 0.3% f.s. ±1digit)
 - **Resistance thermometer:** < 0.3 % f.s. ±1digit
 - **Thermocouples:** < 0.3 % f.s. ±1digit (at type S: < 0.5% f.s. ±1digit)
Point of comparison: ± 1 °C
 - **Frequency, rotational speed, counter:** < 0.1 % f.s. ±1digit

Analog output: (option)

freely scaleable analogue output 0-20mA / 4-20mA or 0-10V

Display: approx. 13 mm high, 4-digit red LED-display

Min-/max-value memory: the max- and min value will be stored.

Interface: serial interface, elect. isolated, EASYBus compatible

Power supply for sensor: integrated isolated power supply for measuring transducer: 24 V DC ±5%, 22mA (for dc-supply 18 V DC)

Miscellaneous: permanent self-monitoring, digital filter function, measuring range boundary (limit)

Voltage supply: 230 V AC, 50/60 Hz (standard)
 optionally other supply voltages are possible

Power consumption: approx. 5 VA
Operating temperature: -20 to +50 °C
Relative humidity: 0 to 80 %RH (non condensing)
Storage temperature: -30 to +70 °C
Housing: standard rack type housing 48 x 96 mm (front frame)
 installation depth: approx. 115 mm (incl. screw-type/plug-in terminals)
Panel mounting: by fixing clamps
 Panel cutout: 43.0^{+0.5} x 90.5^{+0.5} mm (H x W)
Electrical connection: via screw-type/plug-in terminals
 cable diameters from 0.14 to 1.5 mm².
Protection class: front side IP54, with optional sealing IP65
Electromagnetic immunity (EMC): EN61326 (appendix A, class B)

Options (upon upcharge)

- **12VDC** voltage supply = 12 VDC (11-14V) ¹⁾
 - **24VDC** voltage supply = 24 VDC (22-27V) ¹⁾
 - **24VAC** voltage supply = 24 VAC ±5%
 - **115VAC** voltage supply = 115 VAC ±5%
 - **AAG020** analog output 0-20 mA, 4-20 mA (reversible) ¹⁾
 - **AAG010** analog output 0 - 10 V ¹⁾
- 1) For analog output with option 12VDC o. 24VDC add. upcharge

Accessories

GGD 4896 additional sealing for panel mounting IP65

EAK 36 Unit stickers (black with white text)
 for 36 different units for lettering of display devices.



EBW 1 interface converter EASYBus => RS232 (p.r.t. page 92)

EBS 20M software for recording and archiving
 of the measuring values (p.r.t. page 58).

Temperature probes

p.r.t. page 121 - 135

for other accessories p.r.t. page 74/75, 93/94

Front
48 x 96

Universal Displaying and Regulating Device

GIR 2002

On/Off - control mode

GIR 2002 PID with PID - control mode

easy operability - high accuracy - economic price

E.A.S.Y. Bus
- Modul



Highlights

- universal input for normalized signals, frequency, Pt100, Pt1000, thermocouple
- 2 relay switching outputs
- 1 analog output (0(4)-20mA or 0-10V) (optional)
- 5 programmable switching modes
- electrical isolated power supply for a transmitter (24V / 22mA)
- serial interface, bus operation

Additional at GIR 2002 PID

- P, I, PI, PD or PID control mode
- motorised valve control
- continuous regulating output (optional)

Applications

- process regulating
- temperature controller
- Pressure monitoring
- rotation speed display
- flow counter
- etc.

General

The universal controller **GIR 2002** is the ideal device for simple control systems (on/off switching, relay outputs, ...), because of its compact construction and its high ease of use.

The **GIR 2002 PID** (basic version) supplies one control output for a 2-point-control the types of control **P, I, PI, PD** or **PID** and a second control output for on/off switching.

The device can also be configured as a **3-point motorized valve controller** or as controller with **continuous output** (optionally).

Specification:

Measuring input	Measuring / display ranges	Accuracy (at nominal temperature)	Measuring rate
Thermocouples			
FeCu-Ni type J IEC 584	-70,0 ... +300,0°C or -170 ... 950°C	< 0,3 % FS ±1 digit *	approx. 4 meas. / sec.
NiCr-Ni type K IEC 584	-70,0 ... +250,0°C or -270 ... 1372°C	< 0,3 % FS ±1 digit *	
NiCrSi-NiSi type N IEC 584	-100,0 ... +300,0°C or -270 ... 1350°C	< 0,3 % FS ±1 digit *	
Pt10Rh-Pt type S IEC 584	-50 ... 1750°C	< 0,5 % FS ±1 digit *	
Cu-CuNi type T IEC 584	-70,0 ... +200,0°C or -270 ... 400°C	< 0,3 % FS ±1 digit *	
Resistance thermometer			
Pt100 3-wire DIN EN 60751	-50,0 ... +200,0°C or -200 ... 850°C	< 0,3 % FS ±1 digit	approx. 4 meas. / sec.
Pt1000 2-wire DIN EN 60751	-200 ... 850°C	< 0,3 % FS ±1 digit	
Action signals / normalized signal			
0 ... 1 V, 0 ... 2 V, 0 ... 10 V	-1999 ... +9999 Digit, scale freely adjustable	< 0,2 % FS ±1 digit	approx. 100 meas. / sec.
0 ... 20 mA, 4 ... 20 mA		< 0,2 % FS ±1 digit	
0 ... 50 mV		< 0,3 % FS ±1 digit	
Frequency			
TTL-signal	0,000 Hz ... 10 kHz, scale freely adjustable	< 0,1 % FS ±1 digit	approx. 100 meas. / sec.
Switching contact NPN	0,000 Hz ... 3 kHz, scale freely adjustable		
Switching contact PNP	0,000 Hz ... 1 kHz, scale freely adjustable		
Rotational speed	0,000 ... 9999 U/min.	selectable prescaler: 1-1000, pulse frequency: max. 600 000 Imp./min. at TTL	
Flow	0 ... 9999 l/s, 0 ... 9999 l/min. or 0 ... 9999 l/h		
Counter up / down			
TTL-signal, switching contact (NPN, PNP)	0 ... 9999 or 0 ... 999 000 (with prescaler) <i>selectable prescaler: 1-1000, pulse frequency: max. 10 000 Imp./sec. at TTL</i>	< 0,1 % FS ±1 digit	approx. 100 meas. / sec.
Serial interface: displaying and controlling from values coming via the serial interface			

* = Point of comparison: ± 1 °C

General (continuance)

Due to the **universal input** and the various **switching functions** the controller can be optimally adapted to the requirements of the system.

The structured menu navigation allows a straightforward handling and a fast adjustment of the parameters.

A **LED switching position display** gives information to the user about the current status of the switching outputs.

The **automatic self-test and diagnostic system** ensures maximum operational safety and reports systems errors by conclusive error codes.

The parameters are automatically saved, so that all data will be maintained even in case of a power blackout.

Among others most of the GREISINGER transmitters, rpm sensors and flow rate sensors can be connected directly to the **integrated transmitter power supply** (24VDC/22mA) of the controller.

If the device is used as a thermocouple or resistance thermometer, the measuring value can be alternatively displayed in **°C or °F**. By means of an offset correction the measured value can be scaled i.e. to the resistivity of the wires.

The current and voltage inputs can be arbitrarily scaled in the range of -1999 to +9999.

The GIR 2002 has a **serial, bus-compatible interface** by default, by which a comfortable adjustment of the parameters as well as recording of measured values is possible.

With the optionally available Windows library EASYBUS.dll up to 240 devices can be integrated into own programs (i.e. LabView).

Specification:

Outputs: *Please note: Not all options are available for both device types and not all options can be combined with each other. Please see therefore the output options diagram.*

Output 1: voltage free relay output (standard)
normally-open contact, switching power: 5 A (ohmic load), 250 V_{AC}

- optional: HLR1: control output for semiconductor relay (6V_{DC}/15mA)
AAG..1: freely scaleable analog output 0(4)-20mA or 0-10V
ST..1: continuous output 0(4)-20mA or 0-10V

Output 2: voltage free relay output (standard)
change-over contact, switching power: 10 A (ohmic load), 250V_{AC}

- optional: HLR2: control output for semiconductor relay (6V_{DC}/15mA)

Output 3: (not available at standard device type)

- optional: REL3: voltage free relay output (chance-over contact)
switching power: 1 A / 40 V_{AC} or 30 V_{DC}
HLR3: control output for semiconductor relay (14V_{DC}/15mA)
NPN3: elec. isolated NPN-switching contact (max. 1 A / 30 V_{DC})
AAG..3: freely scaleable analog output 0(4)-20mA or 0-10V
ST..3: continuous output 0(4)-20mA or 0-10V

Controller states: 5 or 6, selectable
(e.g. 2-point regulator, 3-point regulator, ...)

Switching point, hysteresis: freely adjustable

Response time: ≤ 25 msec. at normalized signals
≤ 0.5 sec. at temperature and frequency

Display: approx. 13 mm high, 4-digit red LED-display

Min-/Max-value memory: the max- and min value will be stored.

Interface: serial interface, electrical isolated, EASYBus compatible

Power supply for sensor: 24 V DC ±5%, 22mA (for dc-supply 18 V DC)

Miscellaneous: permanent self-monitoring, digital filter function, measuring range boundary (limit)

Voltage supply: 230 V AC, 50/60 Hz (standard)
optionally other supply voltages are possible

Power consumption: approx. 6 VA

Operating conditions: -20 ... +50 °C, 0 ... 80 %RH (non condensing)

Housing: standard rack type housing 48 x 96 mm (front frame)
installation depth: approx. 115 mm (incl. screw-type/
plug-in terminals)

Panel mounting: with fixing clamps
panel cutout: 43.0^{+0.5} x 90.5^{+0.5} mm (H x W)

Electrical connection: via screw-type/plug-in terminals
cable diameters from 0.14 to 1.5 mm².

Protection class: front side IP54, with optional sealing IP65

Electromagnetic immunity (EMC): EN61326 (appendix A, class B)

Options:

Output schema	GIR 2002			GIR 2002 PID		
	out 1	out 2	out 3	out 1	out 2	out 3
Standard type:	<i>normally-open contact</i>	<i>chance-over contact</i>	--	<i>normally-open contact</i>	<i>chance-over contact</i>	--
available output options	upcharges					
HLR1: output 1 = control output for external SSR	x			x		
HLR2: output 2 = control output for external SSR		x			x	
REL3: output 3 = relay (chance-over contact)			x			x
HLR3: output 3 = control output for external SSR			x			x
NPN3: output 3 = npn-switching output			x			x
AAG020/1: output 1 = analog output 0(4) - 20 mA	x		<i>no out3 possible</i>			
AAG010/1: output 1 = analog output 0 - 10 V	x					
AAG020/3: output 3 = analog output 0(4) - 20 mA			x			x
AAG010/3: output 3 = analog output 0 - 10 V			x			x
STA1: output 1 = continuous output 0(4) - 20 mA				x		<i>no out3 possible</i>
STV1: output 1 = continuous output 0 - 10 V				x		
STA3: output 3 = continuous output 0(4) - 20 mA						x
STV3: output 3 = continuous output 0 - 10 V						x

¹⁾ At continuous or analog output or npn-switching output with option voltage supply = 12 V_{DC} or 24 V_{DC}

add. upcharge

²⁾ At output type REL3 or HLR3 with option voltage supply = 12 V_{DC}

add. upcharge

Further Options:

- **12VDC** voltage supply: 12 V_{DC} (11-14V) ¹⁾

- **24VDC** voltage supply: 24 V_{DC} (22-27V) ¹⁾

- **24VAC** voltage supply: 24 V_{AC} ±5%

- **115VAC** voltage supply: 115 V_{AC} ±5%

upcharge

Accessories:

GGD4896 additional sealing for panel mounting IP65

EAK 36 Unit stickers (black with white text) for 36 different units for lettering of display devices (p.r.t. page 65)

Temperature probes

p.r.t. page 121 - 135

for other accessories p.r.t. page 58, 74/75, 93/94

Front
48 x 96

Controller with external predetermined desired value

E.A.S.Y. Bus
- Modul



GIR 2002 / SW GIR 2002 PID / SW

Applications

- predetermined control
- program control with external set point
- temperature regulation dependent on ambient temperature
- flow rate regulation with set point input via rotary potentiometer
- etc.

General

The technical data of the set-point-regulators are largely identical to that ones of the GIR 2002 and GIR 2002 PID. The difference is that the input for 0-10V normalized signals is used as set-point input.

Specification

Measuring input: universal input for
- normalized signals: 4-20 mA, 0-20 mA, 0-1 V, 0-2 V, 0-50 mV
- resistance thermometer: Pt100 (3-wire), Pt1000 (2-wire)
- thermocouples: types J, K, N, S, T
- frequency: TTL-signal, switching contact
- flow, rotational speed: TTL-signal, switching contact
- counter up/down: TTL-signal, switching contact
Display range: -1999 ... 9999 digit,
 decimal point, initial and final values freely selectable

Recommended range: ≤ 2000 digit

Set-point input: 0 ... 10 V, freely scalable (for switching point 1)

Outputs: 1 normally open contact, 1 change-over contact
output options like HLR-control output, analog output or continuous output available - p.r.t. page 67

Controller states: 5 or 6, selectable
 (e.g. 2-point-regulator, 3-point-regulator, ...)

Limit values: freely selectable

Miscellaneous:

Display: approx. 13 mm high, 4-digit red LED-display
Operating conditions: -20 ... +50 °C, 0 ... 80 %RH (non condensing)
Voltage supply: 230 V AC, 50/60 Hz, approx. 6 VA
Housing: standard rack type housing **48 x 96 mm** (front frame)
 installation depth: approx. 115 mm (incl. screw-type/ plug-in terminals)
Electrical connection: via screw-type/ plug-in terminals:
 cable diameters from 0.14 to 1.5 mm².
Protection class: front side IP54 (IP65 on request)
Electromagnetic immunity (EMC): EN61326 (appendix A, class B)

for further technical date refer to GIR 2002 (page 67)

Options (upon upcharge)

- output options (e.g. HLR..., AAG..., ST...) *see page 67*
- other voltage supply *see page 67*

Front
48 x 96

2-channel difference controller

E.A.S.Y. Bus
- Modul



GIR 2002 NS / DIF - ... *1

*1 = Please state your desired input signal at order transaction!
 020 = (2x) 0-20 mA, 420 = (2x) 4-20 mA, 010 = (2x) 0-10 V

Applications

- difference controller for 2 channels
- detection of leaks
- control of delivery and exit air
- pressure compensation
- etc.

General

The **GIR 2002 NS / DIF** is a display, control and regulating device for difference measurements. The measuring inputs are designed for standard signals. Please state your desired input signal at order transaction.

Specification

Measuring inputs: (2 x) 4-20 mA, (2 x) 0-20 mA or (2 x) 0-10 V
Please state your desired input signal at order transaction!
Display range: -1999 ... 9999 digit,
 decimal point, initial and final values freely selectable

Recommended range: ≤ 2000 digit

Accuracy: $< 0.2\%$ FS ± 1 digit (at nominal temperature = 25°C)

Measuring rate: approx. 100 meas. / sec.

Display/regulation: difference: input 1 - input 2

Outputs: 1 normally open contact, 1 change-over contact
output options like HLR-control output, analog output or continuous output available - p.r.t. page 67

Controller states: 5 or 6, selectable
 (e.g. 2-point-regulator, 3-point-regulator, ...)

Limit values: freely selectable

Miscellaneous:

Display: approx. 13 mm high, 4-digit red LED-display
Operating conditions: -20 ... +50 °C, 0 ... 80 %RH (non condensing)
Voltage supply: 230 V AC, 50/60 Hz, approx. 6 VA
Housing: standard rack type housing **48 x 96 mm** (front frame)
 installation depth: approx. 115 mm (incl. screw-type/ plug-in terminals)
Panel mounting: with fixing clamps
 panel cutout: 43,0^{+0.5} x 90,5^{+0.5} mm (H x W)
Electrical connection: via screw-type/ plug-in terminals:
 cable diameters from 0.14 to 1.5 mm².
Protection class: front side IP54 (IP65 on request)
Electromagnetic immunity (EMC): EN61326 (appendix A, class B)

for further technical date refer to GIR 2002 (page 67)

Options (upon upcharge)

- output for HLR-connection (HLR1, HLR2) *see page 67*
- analog output (AAG.../..)
- other voltage supply *see page 67*



Temperature regulator

GIR 2000 Pt cpl. with probe

GIR 2000 Pt OF without probe



- measuring input for Pt100 (3-wire)
- temperature probe in scope of supply
- integrated switching output
- extensive self-monitoring and diagnostic system
- min-/max value memory

Specification

Measuring input: Pt100 (3-wire)
Measuring range: -50.0 ... +200.0°C
Resolution: 0.1°C
Measuring rate: approx. 4 meas. / sec.
Accuracy: < 0.3 % FS ±1digit (at nominal temperature = 25°C)
Temperature probe: GTF200 Pt100 / 3-wire
 Pt100-probe, DIN class B (±0.3°C at 0°C), V4A-tube Ø5mm 50mm length, approx. 1m silicone cable. (in scope of supply at GIR2000Pt)



Output: voltage free relays output, change-over-contact, switching power: 10A (ohmic load), 250VAC

Controller state: 2-point, min-/max-alarm

Switching point: freely adjustable

Response time: ≤ 0.5 sec.

Display: approx. 13 mm high, 4-digit red LED-display

Min-/max-value memory: the max- and min value will be stored.

Miscellaneous: permanent self-monitoring, digital zero point and scale adjustment

Voltage supply: 230 V AC, 50/60 Hz (standard) optionally other supply voltages are possible
Power consumption: approx. 5 VA
Operating temperature: -20 to +50 °C
Relative humidity: 0 to 80 %RH (non condensing)
Storage temperature: -30 to +70 °C
Housing: standard rack type housing 48 x 96 mm (front frame) installation depth: approx. 115 mm (incl. screw-type/plug-in terminals)
Panel mounting: by fixing clamps
 Panel cutout: 43.0^{+0.5} x 90.5^{+0.5} mm (H x W)
Electrical connection: via screw-type/plug-in terminals cable diameters from 0.14 to 1.5 mm².
Protection class: front side IP54, with optional sealing IP65
Electromagnetic immunity (EMC): EN61326 (appendix A, class B)

Options (upon upcharge)

- **12VDC** voltage supply = 12 VDC (11-14V)
- **24VDC** voltage supply = 24 VDC (22-27V)
- **24VAC** voltage supply = 24 VAC ±5%
- **115VAC** voltage supply = 115 VAC ±5%

Accessories

GGD4896 additional sealing for panel mounting IP65

APG-4 Housing for surface mounting (incl. seal GGD4896)



device assembled in housing

Dimensions: 75 x 125 x 127 mm (H x W x D) (without screw connections)

Cable insert: screw connections M12x1.5 and M16x1.5

Accessories (probes)

GTF 199 Pt100-probe, 3-wire, -50 ... +400°C
 DIN class B, V4A-tube Ø3 x 100mm, approx. 1m silicone cable

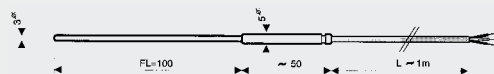

GRO 200 Pt100 tube surface probe, -50 ... +200°C
 DIN class B, sensor body made of aluminium, approx. 2m silicone cable

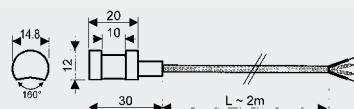

additional suitable temperature probes

p.r.t. page 130

Digital controller for temperature and process values



Autotuned, microprocessor based digital controller with 2-, 3-point or PID control

R 38 (33 x 75 mm)

Specification:

Measuring input: Please specify type required on order!

- Thermocouples: J, K
- Pt100 (2-wire)
- PTC KTY 81-121, NTC 103AT-2
- Pt1000 (2-wire)

Measuring ranges:

Type J: -40...999°C, Type K: -40...999°C, Pt100: -50,0...850°C; PTC: -50,0...+150°C; NTC: -50,0...+109°C; Pt1000: -50,0...-850°C

Resolution: temperature: 0,1 or 1°C (Pt100, Pt100, PTC and NTC: autoranging)

Accuracy: ± 0.5 % FS ±1 digit

Display-Refresh-Time: 1 sec.

Display: 3-digit, 16 mm high LED-display

Outputs: 1 or 2 switching outputs available output versions

- relay output (SPDT, switching power: 8A/3A, 250VAC)
- solid state relay (SSR drive): 10 V DC / 10 mA

Controller state: 2-point, 3-point or PID control.

Autotuning: the autotuning function guarantees the most briefly programming of all requested values.

Housing: 75 x 33 x 64 mm, panel cutout: 71 x 29 mm, Mounting by means of clamping frame

Protection class: front IP65 (mounted in panel with gasket)

Electric connection: screw-type terminals

Operating conditions: 0 ... +50 °C, 20 ... 85 % RH. (non condensing)

Storage temperature: -30 ... +70 °C

Power supply: 100 V - 240 V (± 10% of nominal value)

Power consumption: max. 5 VA

Implementations, Options:

1. Power supply:

- F: power supply: 12V AC/DC
- L: power supply: 24V AC/DC
- H: power supply: 90...240V AC

2. Measuring input:

- F: meas. input: Thermocouples
- A: meas. input: Pt100
- T: meas. input: PTC, NTC, Pt1000

3. Output 1:

- R: relay output
- O: SSR drive

4. Output 2:

- R: relay output
- O: SSR drive

Orderinformation: (Attention: measuring input has to be stated!)

	1.	2.	3.	4.
R 38	<input type="checkbox"/>	<input type="checkbox"/>	<input type="checkbox"/>	<input type="checkbox"/>

R 38 L A RR: R38 with meas. input Pt100 and 2 outputs (2x relay)

digital controller for temperature and process values



K 31

K 32

Autotuned, microprocessor based digital controller with 2-, 3-point or PID control and adjustable set point gradient (ramp function)

K 31 (33 x 75 mm)

K 32 (33 x 75 mm)

Specification:

Measuring input:

- Pt100 (3-wire) and thermocouples: J, K, S, R and T
- PTC KTY 81-121, NTC 103AT-2
- normalized signals: 0(4) ... 20 mA
- normalized signals: 0(1) ... 5 Volt and 0(2) ... 10 Volt

Measuring ranges:

Pt100: -200...850°C; PTC: -55...+150°C; NTC: -50...+110°C; Typ J: -0...1000°C, Typ K: 0...1370°C, Typ S: 0...1760°C

Resolution: temperature: 0.1, 1°C bzw. 0.1, 1°F normalized signals: scale freely adjustable, -1999...9999 digit

Accuracy: ± 0.5 % FS ±1 digit

Display: 4-digit, 12 mm high LED-display (K31) resp. two lines, each 4-digit, 7 mm high LED-display (K32)

Outputs: till 4 switching outputs available output versions

- relay output (R1 / R2) (change over, switching power: 8A/3A, 250VAC)
- relay output (R3 / R4) (close contact, switching power: 5A/1A, 250VAC)
- solid state relay (SSR drive): 8V DC / 8mA

Controller state: 2-point, 3-point or PID control.

Autotuning: integrated autotuning function

Timer / Programm Controller (optionally): timer realisation / Programm controller function with 8 segments / 4 groups with time and gradient.

Housing: 75 x 33 x 64 mm, panel cutout: 71 x 29 mm,

Protection class: front IP65

Electric connection: screw-type terminals

Operating conditions: 0 ... +55 °C, 30 ... 95 %RH. (non condensing)

Power supply: standard: 12 VAC ±10%, 50/60Hz a. 12 VDC ±10%

options: 24 VAC/DC ±10% or 90...240 VAC ±10%, 50/60Hz

Power consumption: approx. 4 VA

Implementations, Options:

1. Functions:

- : controller
- T: controller + timer
- P: controller + programm controller

2. Power supply:

- F: power supply: 12V AC/DC
- L: power supply: 24V AC/DC
- H: power supply: 90...240V AC

3. Measuring input:

- C: meas input: Pt100 und Thermoelement
- E: meas input: PTC, NTC
- I: meas input: current (0-20mA, 4-20mA)
- V: meas input: voltage (0-5V, 0-10V, 1-5V, 2-10V)

4. Outputs:

- R: relay-output **1Rel. 2Rel. 3Rel. 4Rel.**
- O: SSR drive

5. Serial Interface:

S: with serial interface (RS485)

Orderinformation: (Attention: measuring input has to be stated!)

	1.	2.	3.	4.	5.
K 3x	<input type="checkbox"/>	<input type="checkbox"/>	<input type="checkbox"/>	<input type="checkbox"/>	<input type="checkbox"/>

K 31 - H E RO-- -: K 31 with meas. input Pt100, 230VAC power supply and 2 outputs (1x relay, 1x SSR drive)

digital controller for temperature and process values



Autotuned, microprocessor based digital controller with 2-, 3-point or PID control, 3-point motor valve control and adjustable set point gradient (ramp function)

TLK 43 (48 x 48 mm)

Specification:

Measuring inputs: universal input for

- resistance thermometer: Pt100 (3-wire)
- PTC KTY 81-121, NTC 103AT-2 (2-wire)
- Thermocouples: B, C, E, J, K, L, N, R, S, T
- Normalized signals: 0...20mA, 4...20mA, 0...5V, 0...10V, 1...5V, 2...10V
- mV signals: 0...50mV, 0...60mV, 12...60mV

Measuring ranges:

Pt100: -200...850°C; PTC: -55...+150°C; NTC: -50...+110°C;
Type J: -160...1000°C, Type K: -270...1370°C, Type S: -50...1760°C

Resolution: temperature: 0.1, 1°C or 0.1, 1°F

normalized signals: scale freely adjustable, -1999...9999 digit

Accuracy: ±0.15 % FS ±1 digit

Display: two lines, each 4-digit, 7 mm high LED-display

Outputs: up to max. 4 outputs

- available output versions (standard = relay-output)
- relay output (close contact, switching power: 5A/2A, 250VAC)
- solid state relay (SSR drive): 14V DC / 7mA
- normalized signal 0(4) ... 20 mA or 0(2) ... 10 Volt

Please pick the possible combinations from the "Output options"-table.

Controller state: 2-point, 3-point or PID (single or double action) control, continuous, 3-point motor valve control

Autotuning: integrated autotuning function

Alarm outputs: max. 3 (depending from output configuration)

Analog output: scaleable (normalized signal output necessary)

Interface [option]: RS485, optoisolated

Control input [option]: digital input that permit the remote commutation of the set point.

Heater break function [option]: the controller is available with a current transformer input for the heater break monitoring

Housing: 48 x 48 x 98 mm, panel cutout: 45.5 x 45.5 mm,

Mounting by means of clamping frame

Protection class: front IP54 (mounted in panel with gasket)

Electric connection: screw-type terminals

Operating conditions: 0 ... +55 °C, 30 ... 95 %RH. (non condensing)

Power supply: standard: 90...240 VAC ±10%, 50/60Hz., approx. 10VA
option: 24 VAC ±10%, 50/60Hz and 24 VDC ±10%

Implementations, Options:

1. Power supply:

L: power supply: 24V AC/DC

H: power supply: 90...240V AC

2. Outputs: 1Rel. 2Rel. 3Rel. 4Rel.

R: relay-output

O: SSR drive

C: Normalized signals 0(4)...20mA

V: Normalized signals 0(2)...10V

Limitations: If RS485 is chosen, OUT4 is not possible.
OUT3 and OUT4 have to have the same output option.

3. Digital control input and serial interface:

I: with control input and serial interface (RS485)

4. Heater break function:

H: current transformer input

Orderinformation:

1. 2. 3. 4.
TLK 43

TLK 43 L RROO I -: TLK 43 with serial interface and 4 outputs
(2x relay and 2x SSR).

digital controller for temperature and process values



Autotuned, microprocessor based digital controller with 2-, 3-point or PID control

K 48 (48 x 48 mm)

Specification:

Measuring inputs: universal input for

- resistance thermometer: Pt100 (3-wire)
- PTC KTY 81-121, NTC 103AT-2 (2-wire)
- Thermocouples: J, K, S, R, T, IR
- Normalized signals: 0...20mA, 4...20mA, 0...5V, 0...10V, 1...5V, 2...10V
- mV signals: 0...50mV, 0...60mV, 12...60mV

Measuring ranges:

Pt100: -200...850°C; PTC: -55...+150°C; NTC: -50...+110°C;
Type J: -160...1000°C, Type K: -270...1370°C, Type S: -50...1760°C

Resolution: temperature: 0.1, 1°C or 0.1, 1°F

normalized signals: scale freely adjustable, -1999...9999 digit

Accuracy: ±0.15 % FS ±1 digit

Measuring rate: approx. 8 measurements / sec.

Display: 4-digit, 12 mm high LED-display

Outputs: up to max. 3 outputs

- available output versions (standard = relay-output)
- relay output (R1/R2) (close contact, switching power: 8A/3A, 250VAC)
- relay output (R3) (close contact, switching power: 5A/2A, 250VAC)
- solid state relay (SSR drive): 14V DC / 20mA

Please pick the possible combinations from the "Output options"-table.

Controller state: 2-point, 3-point or PID (single or double action) control

Autotuning: integrated autotuning function

Timer / Programm Controller (optionally): timer realisation / Programm controller function with 8 segments / 4 groups with time and gradient.

Alarm outputs: max. 3 (depending from output configuration)

Housing: 48 x 48 x 98 mm, panel cutout: 45.5 x 45.5 mm,

Mounting by means of clamping frame

Protection class: front IP54 (mounted in panel with gasket)

Electric connection: screw-type terminals

Operating conditions: 0 ... +55 °C, 30 ... 95 %RH. (non condensing)

Power supply: standard: 90...240 VAC ±10%, 50/60Hz.
option: 24 VAC ±10%, 50/60Hz and 24V VDC ±10%

Implementations, Options:

1. Functions:

- : controller
- T: controller + timer
- P: controller + programm controller

2. Power supply:

L: power supply: 24V AC/DC

H: power supply: 90...240V AC

3. Measuring input:

C: meas input: Pt100 und Thermoelement

E: meas input: PTC, NTC

I: meas input: current (0-20mA, 4-20mA, ...)

V: meas input: voltage (0-5V, 0-10V, 1-5V, 2-10V, ...)

4. Outputs: 1Rel. 2Rel. 3Rel.

R: relay-output

O: SSR drive

D: digital control input

whereas R1 and R2: 8A/3A switching; R3: 5A/2A switching

Orderinformation:

1. 2. 3. 4.
K 48

K 48 - L C RR -: K 48 controller with 2x relay.

Self-supplying plug-in display for 4-20 mA measuring transducer
no auxiliary energy source required - device will tap from loop current.

GIA 0420 VO



GIA 0420 VOT



GIA 0420 VO without buttons

GIA 0420 VOT with buttons

GIA 0420 VOT - ex



with Ex-protection for all potentially explosive atmospheres

Ex qualification: Ex II 2G Ex ia/ib IIC/IIB T4

(Further Information please refer to our Homepage www.greisinger.de)

Specification:

Input signal: 4-20 mA (2-wire) (optionally 0 ... 10 V)
Voltage load: approx. 2 V (at ...-ex: approx. 3.5 V)
Accuracy: $\pm 0.2\%$ FS ± 1 digit (at nominal temperature = 25°C)
Display: 10 mm high LCD
Display range: -1999 up to +9999
Decimal point: any position
Scale: freely adjustable via 3 buttons
 (for "VO": accessible after cover has been removed)

Measuring rate: approx. 5 measurements / sec.
Filter: adjustable
Limit: 3 limit functions selectable:
 LI 0: Values above/below range permissible
 LI 1: Values above/below range not permissible
 LI 2: When range is exceeded, the referring rail will be displayed

Switching outputs: (only devices with option S1 or S2)

- S1: 1 electrically isolated open collector outputs,
- S2: 2 electrically isolated open collector outputs, connection via separate M8 jack

Switching point, switching hysteresis: freely adjustable

max. switching voltage: 28 V
max. switching current: 1 A (Option S1: 20 mA)

Reaction time: ≤ 250 ms

Min./Max. value memory: memorizing of max. and min. values.

Operation, Configuration: via 3 keys.

Working conditions: -25 to +50°C, 0 to 80 % RH (non-condensing)

Electric connection: special-adaptor design for cubic plug EN 175301-803/A for simple plug-in wherever required. 2 screws (68 and 75 mm) included in scope of supply.

Housing: ABS, keypad (resp. transparent panel made of polycarbonate) approx. 48,5 x 48,5 x 35,5 mm (H x W x D) without special adapter approx. 50,5 x 90 x 39,5 mm (H x W x D) with special adapter
 Protection rating: IP65 (when mounted appropriately)

- no auxiliary energy source required - device will tap from 4 to 20 mA loop current.
- scale freely adjustable 'on site' within seconds, no auxiliary devices required
- can be turned to any position, fits in any position regardless of transmitter location
- large display range from -1999 to 9999 Digit.
- maximum accuracy and minimum temperature drift
- large, 10 mm high LCD
- plug-in wherever required and device will be ready! The quickest way possible to get an "on site display" for your 4 to 20 mA measuring transducers.
- monitoring for probe damage, probe short circuit, values above/below permissible limit
- steady display even if transmitter signal is disturbed: due to software filters (can be switched on/off)

Options:

- **S1** with 1 electrically isolated switching output
 Delivery incl. 1m connecting cable for connection of switching output (**Option S2 just in combination with Ex-device available**)

- **S2** with 2 electrically isolated switching outputs
 Delivery incl. 1m connecting cable for connection of both switching outputs (**Option S2 not in combination with Ex-device available**)

GIA 0420 WKT

GIA 0420 WKT - ex

with Ex-protection for all potentially explosive atmospheres

Specification:

as GIA 0420 VOT but

Electric connection: connection to any standard signal source (4-20 mA) via 2 m connection cable.

Housing with mounting holes can be mounted to any surface.



Option: Input signal 0 ... 10 V (3-wire)

Display with power supply (12 ... 28 V) power consumption: < 10 mA

Unrivalled High Tech In Miniature Format

GRA 0420 VO

Plug on controller/display needs no auxiliary energy
freely scaleable via 3 keys



- LED-display
 - no auxiliary energy source required
 - with 1 open collector output
 - optional with 2 electrically isolated high current open collector switching outputs (28V / 1A)
 - 4 switching functions
 - selectable preference state of switching outputs
 - fast controlling and supervision (reacting time <20ms)
 - alternatively available version: 0-10V (auxiliary energy required)
 - Min./Max. value memory
 - 3 limit functions, 3 filter stages
- alarm delay adjustable
 - extensive self check and diagnosis system

GRA 0420 VO

Without auxiliary energy, output 4-20mA, 1 electrically isolated switching output.

GRA 010 VO

Output 0-10V, 1 +Ub-switching switching output.

Specification:

	GRA 0420 VO...	GRA 010 VO..
Input signal:	4 ... 20 mA (2-wire)	0 ... 10 Volt (3-wire)
Voltage load:	< 5.5 V	
Input resistance:		approx. 30 kOhm
Supply voltage:		12 - 28 Volt
Supply current:	from current loop	< 10 mA
Display:	4 digit LED, approx. 7 mm high	
Display range:	-1999 ... 9999 digit, first and last value freely adjustable	
Recommended range:	≤ 2000 digit	
Decimal point:	any position	
Accuracy:	< 0.2% FS ±1digit (at nominal temperature = 25°C)	
Measuring rate:	> 50 measurements / sec.	
Filter:	selectable in 3 stages	
Limit:	3 limit functions selectable:	
	LI 0: Values above/below range permissible	
	LI 1: Values above/below range not permissible	
	LI 2: When range is exceeded, the referring rail will be displayed	

Switching outputs:

GRA0420VO, 1 electrically isolated open collector output, connection via cubic plug

GRA010VO: 1 +Ub-switching open collector output, connection via cubic plug

Option ... - S2: 2 electrically isolated open collector outputs, connection via separate M8 jack

Switching point, switching hysteresis: freely adjustable

max. switching voltage: 28 V

max. switching current: 20 mA (at option ... - S2: 1 A)

Reaction time: ≤ 20 ms

Switching functions: 2 or 3 point controller, 2 point controller with min-/max-alarm or separate min-/max-alarm

Min./Max. value memory: memorizing of max. and min. values.

Operation, Configuration: via 3 keys.

Working temperature: -25 to +50°C

Relative humidity: 0 to 80 % RH (non-condensing)

Electric connection: special-adapter design for cubic plug EN 175301-803/A for simple plug-in wherever required. 2 screws (68 and 75 mm) included in scope of supply.

Housing: ABS, keypad (resp. transparent panel made of polycarbonate) approx. 48,5 x 48,5 x 35,5 mm (H x W x D) without special adapter approx. 50,5 x 90 x 39,5 mm (H x W x D) with special adapter
Protection rating: IP65 (when mounted appropriately)

Option:

- **S2** design type with 2 electrically isolated switching outputs
Outputs with increased switching current (28V / 1 A), connection via separate M8 jack (Delivery incl. 1m connecting cable for connection of both switching outputs)

- **OT** design type without pushbuttons in the cover
(e.g. if the adjustment of the device shouldn't be directly accessible for the user)

GRA 0420 WK

Without auxiliary energy, output 4-20mA, 1 electrically isolated switching output.

GRA 010 WK

Output 0-10V, 1 electrically isolated switching output.

Specification:

same as GRA ... VO, but

Electric connection: connection to any standard signal source and switching output via 2 m connection cable.

Housing with mounting holes can be mounted to any surface whatsoever.



Housing for surface mounting *for build in of devices with the format 24 x 48 or 48 x 96 mm*

	Ordering type / description	suitable for	price
	APG-1 * Housing for surface mounting incl. seal GGD2448 Dimensions: 80 x 82 x 95 mm (H x W x D), without elbow-plug Panel cutout: for 1 display at the format 24 x 48 Connection: elbow-plug in according EN 175301-803/A, 4-pin Protection class: IP65	GIA 20 EB	
	APG-2 * Housing for surface mounting incl. seal GGD2448 Dimensions: 80 x 82 x 95 mm (H x W x D), without screw connections Panel cutout: for 1 display at the format 24 x 48 Cable insert: 2 x screw connections M12x1.5 Protection class: IP65		
	APG-3 * Housing for surface mounting incl. seal GGD2448 Dimensions: 80 x 82 x 95 mm (H x W x D), without screw connections Panel cutout: for 2 displays at the format 24 x 48 Cable insert: 2 x screw connections M12x1.5 Protection class: IP65	GIA 0420	
	APG-4 * Housing for surface mounting incl. seal GGD4896 Dimensions: 75 x 125 x 126 mm (H x W x D), without screw connections Panel cutout: for 1 display at the format 48 x 96 Cable insert: screw connections M12x1.5 and M16x1.5 Protection class: IP65	GIA 0420 SP	
	APG-6 * Housing for surface mounting incl. seal GGD4896 Dimensions: 175 x 125 x 126 mm (H x W x D), without screw connections Panel cutout: for 2 displays at the format 48 x 96 Cable insert: screw connections 2 x M12x1.5 and 2 x M16x1.5 Protection class: IP65	GIA 2448 /WE	
			GTH2448/1,2,3

* Note: All housings without installation device and without unit sticker! These (see page 65) have to be ordered separately! The Installation device will be assembled for free in the housing (on common order) if desired.

Pre-assembled mounting plate *for even easier mounting of the transmitters and devices in 80 x 82 housing*

	MP 8082 mounting plate for 80 x 82 housings <i>The mounting plate (of plastic, black) will be assembled to the ordered device ex works. The mounting flaps allow direct mounting to the wall without opening the housing.</i> Dimensions: 80 x 114 x 6 mm (H x W x D)	all devices at 80 x 82-housing: e.g. GTMU, GRHU, GHTU, GMUD, GPHU 014 MP, OXY 3610 MP, APG-1	
--	---	---	--

Other design types upon request

Semiconductor Relais

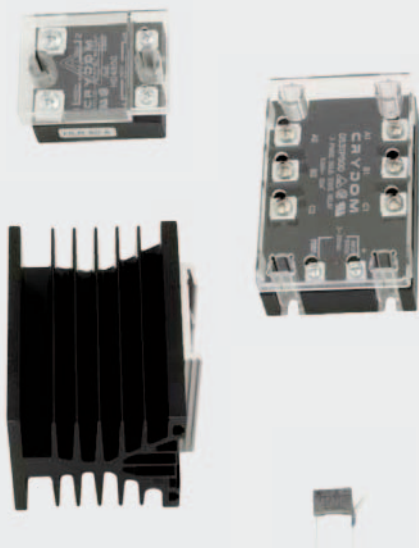

HLR 50A semiconductor relay
 incl. suitable touch-guard protection cap
Switching voltage: 48 ... 530 V AC
Switching current: max. 50 A
Control voltage: 3 - 32 V DC
Isolation voltage: 4000V
Operating temperature: -40...+80°C
Dimensions: approx. 59 x 46 x 35 mm

D53 TP50D 3 phase semiconductor relay
 incl. suitable touch-guard protection cap
Switching voltage: 48 ... 530 V AC
Switching current: max. 50 A
Control voltage: 3 - 32 V DC
Isolation voltage: 4000V
Operating temperature: -40...+80°C
Dimensions: approx. 100 x 75 x 35 mm

D53-3P Suitable heat sink for D53TP50D
 snap-on mounting on hat rail

RC-element 230 VAC for inductive switching loads
 (solenoids, relay, motors etc.)

Power supply

GNG 220 / 2

Power supply device integrated in snap-on housing for top hat rail - for 2 transmitter

Input voltage: 230 V, 50/60 Hz
Output voltage: 2 x 18 V DC $\pm 5\%$, 25 mA each
Dimensions: 48 x 96 x 52 mm (W x H x D)
Mounting: snap-on to top hat rail

GNG 220 / 2 - 12V

identical to GNG220/2, but with output voltage 2 x 12 V DC, 30 mA each

GNG 220

identical to GNG220/2, but with output voltage 1 x 12 V DC, 100 mA, unregulated

GNG 12 / 300

Power supply device integrated in snap-on housing for top hat rail

Input voltage: 230 V, 50/60 Hz
Output voltage: 12 V DC $\pm 5\%$, 300 mA
Dimensions: 70,4 x 96 x 62 mm (W x H x D)
Mounting: snap-on to top hat rail

GNG 24 / 150

identical to GNG12/300, but with output voltage: 24 V DC $\pm 5\%$, 150 mA

other voltage upon request

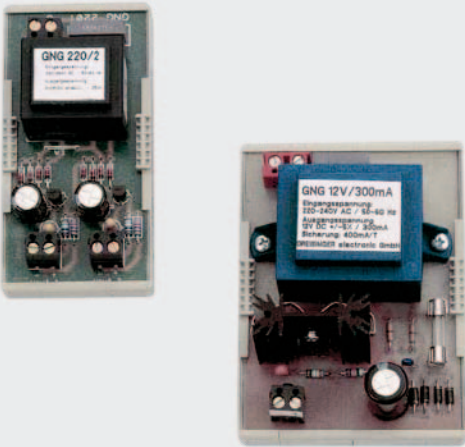

DC/DC-converter

GNG 12 / 24

GNG 24 / 24

DC/DC-converter to electrically isolate 12V or 24V DC-supply voltages

Input voltage: GNG12/24: 10 - 18 V DC
 GNG24/24: 19 - 30 V DC
Output voltage: 24 V DC $\pm 5\%$, max. 80 mA, electrically isolated
Insulating voltage: 500 V
Operating temperature: -20 ... +70° C
Mounting: snap on to top hat rail.
Dimensions: minimum space requirements due to narrow rack housing (module fully encapsulated). Installation width only 22.5 mm.

GNG 12 / 2 x 24

GNG 24 / 2 x 24

Input voltage: GNG 12 / 2 x 24: 10 - 18 V DC
 GNG 24 / 2 x 24: 19 - 30 V DC
Output voltage: 2 x 24V DC $\pm 5\%$, max. 80 mA each, electrically isolated
 other data identical to GNG12/24 resp. GNG24/24



Power supply and relay module (e.g. for GIA20EB)

GNR10

Power supply and relay module for top-hat rail

Power supply for one GIA20EB and one transducer.

Input voltage: 230V, 50/60Hz (others upon request)
Output voltage: approx. 11V DC (unregulated) for the supply of a GIA20EB.
 18V DC $\pm 5\%$ (regulated), 25 mA for meas. transducer
Relay outputs: 2 volt-free changeover contacts,
 switching current: max. 10 A ohmic load.

Connection: screw-type terminal
Dimensions: 48 x 96 x 60 mm (W x H x D)
Mounting: snap on to top hat rail

GR10

Relay module for top-hat rail

for one GIA20EB to mounting to a top-hat rail

Input voltage: 12V DC (others e.g. 24VDC upon request)
Relay outputs: 2 volt-free changeover contacts,
 switching current: max. 10 A ohmic load.
Connection: screw-type terminal
Dimensions: 48 x 96 x 60 mm (W x H x D)
Mounting: snap on to top hat rail

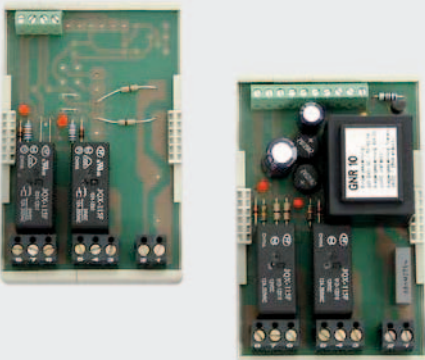

DIGITAL-PANEL-MOUNTED DISPLAY MODULES for all applications

- 2 temperature modules (covering temperature ranges from -50 up to +1150° C)
- 4 pressure modules for barometer, vacuum meter, manometer for absolute pressure, over/under pressure and pressure difference measurements. Pressure range up to 10 bar
- one voltmeter module with 3 integrated voltage ranges

Common specification for all modules:

Display: 3½-digit LCD display, 13mm high (±1999 digit), **scan rate:** 3 meas. per second, **operating temperature:** 0 to 50°C, **atmospheric humidity:** 0 to 85%RH (non-condensing), **storage temperature:** -10 to +70°C, **current supply:** 9 - 12 V DC, **electrical connection:** via soldering pin, **dimensions:** 38 x 76 x 22 mm (H x W x D), **panel-cutout:** 36^{+0.5} x 73.2^{+0.5}mm (H x W), **panel thickness:** max. up to 9.5mm. snap-on frame protruding only 1mm over front plate - professional design, 3mm thick anti-reflex screen

TEMPERATURE

GPT 180

TEMPERATURE MODULE for semiconductor sensor KTY 83-110

Range: -50.0 up to +175.0° C / **Resolution:** 0.1° C

Accuracy: approx. 1% f.s. / **Power consumption:** approx. 1 mA

Suitable sensors KTY 83-110: please refer to pages 128

GPT 1155

TEMPERATURE MODULE for thermocouple NiCr-Ni (type K)

Range: -50 up to +1150° C / **Resolution:** 1° C

Accuracy: (at nominal temperature = 25°C) better than 1 % from -20 up to +550 and from 920 up to 1150° C, 550 up to 920 better than 1.5%

Power consumption: approx. 0.35 mA

Suitable sensors type NiCr-Ni (type K) p.r.t. pages 123 - 127, 132 - 133

GTU 300/152 wire sensor with soldering pin plug

Pressure

GPD 15 ABS

DIGITAL BAROMETER / VACUUM METER MODULE (sensor not included)

Range: 0 to 1100 mbar (hPa) absolute / **Resolution:** 1 mbar

Accuracy module: 1 mbar ±1 digit

Accuracy sensor: (sensor not included in scope of supply):

±0.2% (typical) for linearity and hysteresis, ±0.4% for temperature drift from 0 to 50° C (typ. values for sensors compensated to module)

Power consumption (incl. sensor) approx. 3.5 mA

Suitable sensors: (please order separately)

SCX 15 ANC (pressure sensor, loose)

SCX 15 ANC/G (pressure sensor with housing, 1m connection cable)

GPD 05 REL

DIGITAL MANOMETER for over/under pressure and pressure difference (sensor not included)

Meas. range: -100,0 to +199,9 mbar relative (referring to ambient pressure)

Resolution 0,1 mbar / **Accuracy module** 0,1 mbar ±1 digit

Accuracy sensor and power consumption as above

Suitable sensors: (please order separately)

SCX 05 DNC (pressure sensor, loose)

SCX 05 DNC/G (pressure sensor with housing, 1m connection cable)

GPD 30 REL

DIGITAL MANOMETER for over/under pressure and pressure difference (sensor not included)

Meas. range: -1000 to +1999 mbar relative (referring to ambient pressure)

Resolution 1 mbar / **Accuracy module** 1 mbar ±1 digit

Accuracy sensor and power consumption as above

Suitable sensors: (please order separately)

SCX 30 DNC (pressure sensor, loose)

SCX 30 DNC/G (pressure sensor with housing, 1m connection cable)

GPD 150 REL

DIGITAL MANOMETER for over/under pressure and pressure difference (sensor not included)

Range: -1.00 up to 10.00 bar relative (referring to ambient pressure)

Resolution 0.01 bar **Accuracy module** 1 mbar ±1 digit

Accuracy sensor and power consumption as above

Suitable sensors: (please order separately)

SCX 150 DNC (pressure sensor, loose)

SCX 150 DNC/G (pressure sensor with housing, 1m connection cable)

DIGITAL DISPLAY for all measuring transducers 4 to 20 mA 2-wire, no auxiliary power required



Digital panel module without auxiliary energy

- for use in 4 to 20 mA output circuits of measuring transducers
- WITHOUT EXTERNAL AUXILIARY SUPPLY
- high operating reliability
- Cost reduction as power supplies and their cables are no longer required

GTA 0420 (standard range)

Large, high-contrast 3 1/2 digit LCD, 12.7 mm high; to either directly display loop current or convert it into any desired value such as temperature, pressure, fill level, humidity, travel, weight, height, liquid flow, ppm, mg/l, % sat., etc..

Snap-on, industrial panel-mounting type, anti-reflex screen 3 mm thick (not to be compared with unprotected glass covered display as used with cheap modules!)

Minimum size: 38 x 76 x 22 mm (H x W x D). Devices can be stack-mounted at a distance of 38 mm.

Standard printings available, eg. °C, %, V, mbar, bar, otherwise neutral.

Specification:

Input signal: 4 .. 20 mA, 2-wire

Display ranges: 0,0 ... 100,0; 0,0 ... 199,9; -50,0 ... +50,0 (standard); any display range desired against upcharge (p.r.t. options)

Decimal point: any place (soldering jumper)

Fine tuning: starting point at 4 mA and end point at 20 mA can each be shifted by ±50 digits

Display: 3½ digit LCD with ±1999 digits, 13 mm high

Scanning rate: 3 measurements per second

Voltage load: approx. 4,7 V (standard - connection wrong-polarity protected) optional: approx. 3,5 V (without polarity protection) - upon request

Accuracy: (at nominal temperature = 25°C) ±0.1% ±1digit

Temperature coefficient: 100 ppm / K

Operating temperature: 0 to 50 °C

Atmospheric humidity: 0 to 85 %RH (non-condensing)

Storage temperature: -10 to +70°C

Dimensions: 38 x 76 x 22 mm (H x W x D)

Panel cutout: 36^{+0.5} x 73.2^{+0.5} mm (H x W)

Panel thickness: max. up to 9.5mm.

Options:

Any measuring range desired (against upcharge)

(no upcharge for orders as of 10 pieces of the same range)

Further displays without auxiliary supply: p.r.t. page 60, 72, 73

VOLTAGE

GPV 220

DIGITAL VOLTMETER, 3 integrated voltage ranges - others can be realised by means of an external voltage divider

Ranges: ±199.9 mV DC, ±1999 mV DC, ±19.99 V DC integrated; (±199.9 V DC or 1999 V DC can be realised by means of an external voltage divider)

Decimal point: any place selectable

Resolution: up to 100µV / **Input impedance:** 100MΩ resp. 1MΩ

Accuracy: 0.1% ±1 digit / **T.C. value:** 100 ppm/K

Power consumption: approx. 100µA only (approx. 3000 hours with normal 9V-battery)

Data logger / EASYBus

	Measurands								EASYBus-Load	Description	Page
	Standard Signal	Temperature	Humidity	Pressure	Pulse	State	Carbon monoxide	Carbon dioxide			

DATA LOGGER

GDUSB 1000				✓					-	USB interface adapter	78
EL-USB-2-LCD		✓	✓						-	USB data logger	78
EL-USB-TC-LCD		✓							-	USB data logger	78
T-Logg 100 ..		✓							-	Stand-Alone logger	79
T-Logg 120 ..	✓								-	Stand-Alone logger	79
T-Logg 160		✓	✓						-	Stand-Alone logger	79
EASYLog 40 K ..		✓							2	EASYBus data logger	80
EASYLog 40IMP/ ..					✓				2	EASYBus data logger	80
EASYLog 24 RFT ..		✓	✓						2	EASYBus data logger	81
EASYLog 40NS ..	✓								2	EASYBus data logger	81
EASYLog 40 BIN						✓			2	EASYBus data logger	82
EASYLog 80 CL		✓	✓	✓					2	EASYBus data logger	82

EASYBus MODULES

EBHT - ..		✓	✓						1,5	EASYBus sensor modul	84
EBT - 2R ..		✓							1,5	EASYBus sensor modul	85
EBT - AP ..		✓							1,5	EASYBus sensor modul	85
EBT - IF ..		✓							1,5	EASYBus sensor modul	86
EBN / ..	✓								2	EASYBus sensor modul	86
EBG - CO - 1R							✓		1	EASYBus sensor modul	87
EBG - CO2 - 1R								✓	1	EASYBus sensor modul	87

EASYBus CONTROLLER

GIA 20 EB									1	Universal display and controller	62
GIA 2000									1	Universal display	65
GIR 2002									1	Universal display and controller	66
EB 2000 MC									-/14	Display- and monitoring device	89
EB 3000									1/30	Display-, controlling- and monitoring device	88

EASYBus INTERFACE CONVERTER

EBW 1									14	Connection to RS 232-interface	92
EBW 3									2	Connection to USB-interface	92
EBW 64									64	Connection to RS 232-interface	92
EBW 240									240	Connection to RS 232-interface	92



The innovation in pressure measurement!

GDUSB 1000

universal USB interface adapter for
GMSD- / MSD-pressure sensors



- large variety of pressure sensors (range 2.5 mbar ... 1000 bar)
- 1000 measurements per second
- pressure peaks registration (1 ms)
- incl. software for visualisation
- no external power supply needed

GDUSB 1000 (device + software)
(for suitable probe please refer to pages 42/43)

Application areas:

- long term monitoring of pressure
- registration of pressure peaks (i.e. at switching operations)
- monitoring of pressure developing (i.e. in process technology)
- checking of working pressure developing in mechanical and plant engineering

General function description:

The GDUS1000 adapter allows the direct connection of a standard pressure sensor of the type GMSD / MSD to the USB interface of a PC. The adapter provides 4 channels: current measured value, average value, Max. and Min. peak, there are also two modes for the measurement available:

Fast-mode: (autom. sending)

At this mode the GDUS 1000 sends automatically the measured values at adjustable intervals after a trigger condition has occurred.

This mode is suitable for the analysis of pressure developments, recording of pressure peaks (with pre-trigger) etc.

The device is handled by the comfortable software GSOFT_USB, which has for example the following functions, i.e.: different trigger conditions for the recording start, analyse and archive the pressure developing. etc.

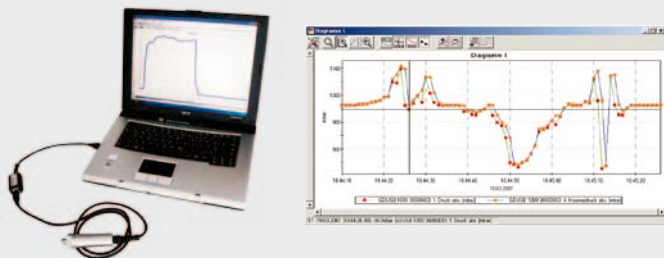

Standard-mode: (master-slave)

At this mode the GDUS1000 behaves like a handheld instrument of the GMH3xxx series and sends the measured value on demand.

The communication can be done via software EBS 20M (p.r.t. p. 91). This mode provides i.e. the opportunity of long term monitoring of pressure.

Specification: (GDUSB1000)

Measuring range: corresponding to connected probe
max. range: -19999 ... +19999 Digit
Pressure units: mbar, bar, Pa, kPa, MPa, mmHg, PSI, mH₂O, switchable, according to the used sensor
Sampling rate: 1000 measurements / sec. (= 1 ms)
Accuracy: ±0.2 % FS (at nominal temperature = 25°C)
Recording interval: 1 ms (at fast-mode) to 10 s via software adjustable

Connections:
PC: Standard USB plug (type A)
GMSD/MSD: 6-pin screened Mini-DIN jack with bolting.
Power supply: via USB interface
Dimensions: 56 x 31 x 24 mm, **Cable length (USB):** 30 cm

System requirements software: CPU with 1GHz, 256 MB RAM
The software is executable with: Windows 98SE, 2000, XP, Vista and 7.

USB Data Logger

with Display for
external Thermocouples (J, K und T) or
Humidity / Temperature and Dew Point



- Direct connection to USB interface
- 2 programmable alarm limits
- LED for indication of low battery power
- Data logger with display
- red, green and orange LED for system status
- IP67
- incl. software

EL-USB-2-LCD (device + software)
USB Data Logger for Humidity / Temperature and Dew Point

EL-USB-TC-LCD (device + software)
USB Data Logger for external Thermocouples (J, K und T)

Specification EL-USB-2-LCD:

Measuring Range: Temperature: -35 ... +80°C
Humidity: 0 ... 100% r.h.
Dew Point via Software

Resolution: 0,5 °C / 0,5% r.h.

Accuracy: Temperature (typ): ± 1°C
Humidity: ± 3,5 %r.F. (in the range 20 till 80 %r.h.)
Dew Point: ± 2°C (in the range 40...100%r.h., 25°C)

Memory: 16.382 recordings per humidity and temperature

Logging Interval: 10 sec, 1 min, 5 min, 30 min, 1 h, 6 h, 12 h programmable via software

Serial Interface: USB

Battery: 3,6V lithium battery, size 1/2 AA, exchangeable

Dimensions: 103 x 26,4 mm (L X W), Ø 27,0mm

Scope of supply: 1 device, 1 lithium battery 3,6V, 1 software, 1 clip
1 protection cap, 1 operating manual (on CD-ROM), 1 clip

Specification EL-USB-TC-LCD:

Measuring Range: Typ J: -130 ... +900°C, Typ K: -200 ... +1300°C
Typ T: -200 ... +350°C

Resolution: 0,5°C

Accuracy (typ.): ± 1,0°C @ 25°C

Thermocouple Connectors: Thermoelement socket in miniature size, suitable for flat-pin plugs

Memory: 32.000 data

Logging Interval: 1 sec, 10 sec, 1 min, 5 min, 30 min, 1 h, 6 h, 12 h adjustable via software

Operating Temp.: Range: -10 ... +40°C

Serial Interface: USB

Battery: 3,6V Lithium battery, size 1/2AA

Battery Life Time: 6 month @ 25°C and recording interval 1 min

Dimensions: 118,2 x 26,8 mm (L X W), Ø 27,0mm

Scope of supply: 1 device incl. 3,6V lithium battery, 1 software, 1 protection cap, 1 operating manual (on CD-ROM), 1 clip, 1 wire temperature probe

Special Note:
EL-USB-2-LCD and EL-USB-TC-LCE are neither BUS- nor EASYBUS compatible.

T-Logg - The logger series for stand-alone applications

TEMPERATURE-LOGGER
for individual programming of
recording time



T-Logg 100 E

T-Logg 100

**DIN EN
12830**

TEMPERATURE DATA LOGGER
(16.000 meas. values) for any application

T-Logg 100

T-Logg 100 E

Starter kit

T-Logg 100 SET

Complete set: T-Logg 100 + USB 100 (incl. software)

Specification

Measuring range:

T-Logg 100: -30,0 ... 60,0 °C

T-Logg 100 E: -30,0 ... 120,0 °C

Resolution: 0,1 °C

Accuracy (at nominal temperature = 25°C):

T-Logg 100: ±0,5 °C

T-Logg 100 E: ±0,2 % of meas. value ±0,5 °C

Sensor:

T-Logg 100: integrated in device
T-Logg 100 E: sensor tube made of stainless steel, Ø5 mm, approx. 50 mm long, approx. 1 m silicone cable. Cable with anti-buckling glanding to housing.

Display:

LCD-display, 10 mm high

Recording interval:

from 2 sec. to 5 h
free programmable via software

Storage capacity:

16.000 measuring values

Recording time:

166 days (if interval is 15 min.)

Working temperature: -30 to +60 °C

Storage temperature: -40 to +85 °C

Battery:

CR2032, exchangeable

Battery service life: over 3 years

(if recording interval is 15 min.)

Approvals:

DIN EN 12830

Interface:

serial interface, 3-pin miniature integral plug. *The T-Logg 100 is not suitable for bus operation and is not E.A.S.Y.Bus compatible!*

Housing:

48,5 x 48,5 x 35,5 mm (H x W x D). plugs, sensor connection, ... are not included

Housing made of shock resistant plastic, transparent front made of polycarbonate, splash water-proof: IP 65 (excl. protection cap at T-Logg 160).

Noise immunity (EMC):

the **T-Logg 100** have been manufactured in accordance with the regulations concerning EMC (2004/108/EG).

The device meets EN 61326-1 (table 2, class B), additional error: < 0,5% (< 1% at T-Logg 100 E)

STANDARD SIGNAL LOGGER
for individual programming of
recording time



T-Logg 120 K

T-Logg 120 W

STANDARD SIGNAL DATA LOGGER
(16.000 meas. values) for transducers etc.

T-Logg 120 W - ...

(with elbow type plug)

T-Logg 120 K - ...

(with PG glanding and cable)

Note: please specify standard signal desired when ordering (i.e.: T-Logg 120 K - 0-1V)

Specification

Display range:

-1999 ... 9999 digit
freely programmable

Decimal point

any position

Input signal: **only one signal!**

0 - 1 V, 0 - 2 V, 0 - 10 V, 0 - 20 mA or 4 - 20 mA
other input signals upon request
(input is not isolated from interface)

Accuracy:

±0,5 % FS (at nom. temperature)

Display :

10 mm high LCD-display

Recording interval:

from 2 sec. to 5 h
freely programmable via software

Storage capacity:

16.000 measuring values

Recording time:

166 days
(if interval is 15 min.)

Working temperature: -25 to +60 °C

Storage temperature: -30 to +85 °C

Battery:

CR2032, exchangeable

Battery service life: over 3 years

(if recording interval is 15 min.)

Electric connection: (for input signals)

... **120 W** - ... elbow-plug in accordance with
EN 175301-803/A for connection
to an existing transmitter.

... **120 K** - ... approx. 0.5 m connection cable

HUMIDITY-/TEMPERATURE-LOGGER
for individual programming of
recording time



**HUMIDITY / TEMPERATURE
DATA LOGGER**

(16.000 meas. values) for any application

T-Logg 160

Starter kit

T-Logg 160 SET

Complete set with T-Logg 100 and interface
converter USB 100 (incl. MINISOFT)

Specification

Measuring ranges, display ranges:

Humidity: 0.0 ... 100.0 %RH

Temperature: -25.0 ... 60.0 °C

Resolution: 0.1 °C / 0.1 %RH

Accuracy (at nominal temperature = 25°C):

Humidity: ≤ ±3 % in range 10 - 90 %

Temperature: ±0,3 °C ± 0.017 * (T - 25°C)

Sensors:

mounted in sensor tube

Sensor tube:

approx. Ø15 mm made of
polyamide with screw-type
plastic protection cap

Display:

10 mm high LCD-display

Recording interval:

from 4 sec. to 5 h
freely programmable via software

Storage capacity:

16.000 measuring values each

Recording time:

166 days
(if interval is 15 min.)

Nominal temperature: 25 °C

Working temperature: -25 to +60 °C

Storage temperature: -30 to +85 °C

Battery:

CR2032, exchangeable

Battery service life: over 3 years

(if recording interval is 15 min.)

Software

MINISOFT

free of charge

Read-out software for the **T-Logg**.

Software is contained at the USB 100 or free
available via the internet (www.greisinger.de).
We will be pleased to send you a separate CD
against a small charge.

*Note: the T-Logg can also be controlled
by the software GSOF40K.*

Accessories

USB 100

interface converter,
for direct connection of one T-Logg to the USB-interface of a PC.

GWH 40K

Wall suspension with lock against theft (picture: see page 93)
suitable for e.g. T-Logg 100, T-Logg 120 K - ... and T-Logg 160.

GWH 10

Simple wall suspension, made of stainless steel (picture: see page 93)
Mount wall suspension at the monitoring point, logger may now be easily put in.

CR 2032

spare battery for T-logg's

TEMPERATURE LOGGER

for watching production and server-rooms as well as cooling chambers according to assignment of frozen food 92/1/EWG

**EASYLog 40K****EASYLog 40KH**

**DIN EN
12830**

TEMPERATURE DATA LOGGER (48.000 meas. values) for any application.

EASYLog 40K sensor tube are attached on the device

EASYLog 40KH sensor tube are connected via 1 m cable

EASYLog 40KH-E300 tube con. via cable, increased meas. range (0,1°C)

EASYLog 40KH-E600 tube con. via cable, increased meas. range (1°C)

EASYLog 40KH-GOF with surface probe for pipe mounting

WPT3 - Certificate of calibration (not available at ..40KH-GOF)
(measuring points: -20°C / 0°C / +60°C (at ..40K) or -20°C / 0°C / +70°C (at ..40KH))

Specification**Measuring ranges:**

EASYLog 40K: -30.0 ... 60.0 °C

EASYLog 40KH: -50.0 ... 150.0 °C

EASYLog 40KH-E300: -50.0 ... 300.0 °C

EASYLog 40KH-E600: 0 ... 600 °C

EASYLog 40KH-GOF: -50.0 ... 150.0 °C

For special measuring ranges refer to options

Working range (electronic): -25 ... 60°C

Resolution display and memory:

0.1°C or 1°C (corresponding type)

Accuracy (at nominal temperature = 25°C):

EASYLog 40K: ±0.5°C

EASYLog 40KH: ±0.5°C

EASYLog 40KH-E300: ±0.5°C ±0.2% of m.v.

EASYLog 40KH-E600: ±1°C ±0.2% of m.v.

EASYLog 40KH-GOF: ±0.5°C ±0.2% of m.v.

Sensor: Pt1000 (2-wire)

- **Design 40K:** (refer upper picture)

sensor tube made of plastic, Ø7 mm, approx. 30 mm long, attached on the device.

(Note: at certificate: stainless steel tube, Ø5 mm, approx. 60 mm long)

- **Design 40KH:** (refer upper picture)

sensor tube made of stainless steel, Ø5 mm, approx. 50 mm long, approx. 1 m silicone cable. Cable with anti-buckling glanding to housing.

- **Design 40KH-E300:** (probe picture below)

sensor tube made of stainless steel, Ø3 mm, approx. 100 mm long, sleeve Ø5 x 50 mm, approx. 1 m glass silk cable. Cable with anti-buckling glanding to housing.

- **Design 40KH-E600:** (probe picture below)

self-adhesive surface temperature probe with moulded silicone design (type GOF 115 Pt1000 - please refer to page 133)

approx. 2 m PFA-insulated cable. Cable with anti-buckling glanding to housing.

- **Special design types upon request**

Display: 10 mm high LCD-display

Recording interval: 2 sec. to 5 h
free programmable via software GSOFT 40K

Storage capacity: 48.000 measuring values

Recording time: 500 days,
(if recording interval is 15 min.)

Battery service life: approx. 6 years (at 15 min)

Working temperature (electronic): -30 to +60 °C

Storage temperature: -40 to +70 °C

Interface: EASYBus-interface

3-pin mini-integral plug.
Needed connection-cable EBSK01 not included in delivery (see accessories page 93)

Note: With an according interface converter you can connect 120 logger without having any problems.

Housing: 48,5 x 48,5 x 35,5 mm (W x W x D)
sensor and plug not included, IP65.

Noise immunity (EMC): the **EASYLog** have been manufactured in accordance with the regulations concerning EMC (2004/108/EG).

The device meets EN 61326-1 (table 2, class B) additional error: < 0,5%

Approvals: DIN EN 12830

Options (for extra charge)

- **DBK: double battery capacity**
recommended for high measure-rates

- **ALARM: additional alarm-output**
open-collector output via 4-pole miniature mounting connector (IP65) including 1 m cable. Max. switching power: 28 V, 50 mA

- **AFK: plugable probe-cable**
4-pole (IP65) miniature mounting connector including assembling of the temperature-probe to the corresponding connection socket

- **SMB: extra measuring range**
freely selectable between -200...+600°C. The essential probe-adjustment is not included in this price.

Note: at a measuring span ≤400°C (e.g. ±200°C) a resolution of 0,1°C is possible. Taller ranges have a resolution of 1°C

PULSE-LOGGER

for consumption and flow rate measuring, piece counting etc.

**PULSE DATA LOGGER**

(48000 meas. values) for individual use

EASYLog 40IMP/S

(type switching contact - with PG-glanding and cable)

EASYLog 40IMP/T

(type TTL-signal - with PG-glanding and cable)

Specification

Measuring range: 0 ... 30000 pulses/cycle

Resolution: 1 pulse

Cycle: 2 sec. to 5 h,
free programmable via software GSOFT 40K

Display range: -1999 to 9999 Digit
free programmable

Decimal point: any position

Input signals:
EASYLog 40IMP/S: passive volt-free switching contact

EASYLog 40IMP/T: active TTL-signal
(input is not isolated for EASYBus)

Resolution display and memory: 1 digit

Accuracy: cycle time ±50 msec

Display: 10 mm high LCD-display

Recording interval: equal to cycle

Storage capacity: 48.000 measuring values

Recording time: 500 days,
(if recording interval is 15 min.)

Battery service life: approx. 6 years (without switching current, at 15 min)

Working temperature: -25 to +60°C

Storage temperature: -30 to +70°C

Interface: EASYBus-interface
3-pin mini-integral plug.

Needed connection-cable EBSK01 not included in delivery (see accessories page 93)

Housing: 48,5 x 48,5 x 35,5 mm (L x B x H)
plug and cable not included, IP65

Electric connection: (for input signals)
approx.. 0.5m connection cable, flying leads

Noise immunity (EMC): the **EASYLog** have been manufactured in accordance with the regulations concerning EMC (2004/108/EG).

The device meets EN 61326-1 (table 2, class B) additional error: < 0,5%

Options (for extra charge)

- **DBK: double battery capacity**
recommended for high measure-rates

- **ALARM: additional alarm-output**
open-collector output via 4-pole miniature mounting connector (IP65) including 1m cable. Max. switching power: 28V, 50mA

HUMIDITY-/TEMPERATURE-LOGGER

for museums, greenhouses, medicine technology etc.

E.A.S.Y. Bus
- Modul



EASYLog 24RFT

E.A.S.Y. Bus
- Modul



EASYLog 24RFT-E

HUMIDITY / TEMPERATURE DATA LOGGER
(48.000 measuring values each) for climate monitoring.

EASYLOG 24RFT EASYLOG 24RFT-E

WPF4 - Certificate of calibration humidity (measuring points: approx. 20/40/60/80%)

Specification

Measuring range, Display ranges:

Humidity: 0,0 ... 100,0 %RH
Temperature: -25,0 ... 60,0 °C

Resolution display and memory:

0.1 °C and 0,1 %RH

Accuracy (at nominal temperature = 25°C):

Humidity: ≤ ±3 % in range 11-90%
Temperature: ±0,5°C

Sensors:

high-quality capacitive polymer humidity sensor and Pt1000 temperature sensor

Sensor tube:

EASYLog 24RFT: Ø15mm made of polyamide
EASYLog 24RFT-E: approx. Ø14 x 68mm made of PVDF, connected to logger via 1m teflon cable

Protection cap:

screw-type plastic protection cap for quick responses

Display:

LCD-display, 10 mm high

Recording interval:

4 sec. to 5 h
free programmable via software GSOFT 40K

Storage capacity:

48.000 measuring values each channel

Recording time:

500 days,
(if recording interval is 15 min.)

Battery service life:

approx. 6 years (at 15 min)
double battery capacity against upcharge available!

Working temperature:

-25 to +60°C

Storage temperature:

-30 to +70°C

Interface:

EASYBus-interface
3-pin mini-integral plug.

Needed connection-cable EBSK01 not included in delivery (see accessories page 93)

Note: With an according interface converter you can connect 120 logger without having any problems.

Housing:

48,5 x 48,5 x 35,5 mm (H x W x D) sensor and plug not included. Housing made of shock resistant plastic, transparent front made of polycarbonate, splash water-proof: IP 65 (excl. protection cap)

Noise immunity (EMC): the **EASYLOG** have been manufactured in accordance with the regulations concerning EMC (2004/108/EG). The device meets EN 61326-1 (table 2, class B) additional error: < 0,5%

Options (for extra charge)

- DBK: double battery capacity

recommended for high measure-rates

- ALARM: additional alarm-output

open-collector output via 4-pole miniature mounting connector (IP65) including 1m cable. Max. switching power: 28V, 50mA

Accessories (p.r.t. page 76, 78/79)

EBW 1

Level converter for connection of up to 9 EASYBus data logger to the RS232-interface of a PC. (Power supply: 230V/50Hz)

EBW 3

Level converter for connection of one EASYBus data logger to the USB-interface of a PC. (Power supply: via USB)

GSOFT 40K incl. EBSK01

(connection cable EBSK01 in scope of supply) Windows software for setting of device, data readout and printing of the stored data. (for further description p.r.t. page 90)

EBSK 01

Special connector with approx. 1m cable for the connection of one **EASYLOG**. (note: cable is in scope of supply of the software GSOFT 40K)

STANDARD SIGNAL LOGGER

replaces for expensive recorders

E.A.S.Y. Bus
- Modul



EASYLog 40NS W

STANDARD SIGNAL DATA LOGGER
(48.000 meas. values) for transducers etc.

EASYLog 40NS W - ...
(with elbow type plug)

EASYLog 40NS K - ...
(with PG glanding and cable)

Note: please specify standard signal desired when ordering

Specification

Display range:

-1999 to 9999 Digit
free programmable

Decimal point:

any position

Input signals: **one signal only!**

0 - 2 V, 0 - 10 V, 0 - 20 mA or 4 - 20 mA
other input signals upon request
(input is not isolated for EASYBus)

Accuracy:

±0,5% (at nom. temperature)

Display:

10 mm high LCD-display

Recording interval:

2 sec. to 5 h
free programmable via software GSOFT 40K

Storage capacity:

48.000 measuring values

Recording time:

500 days,
(if recording interval is 15 min.)

Battery service life:

approx. 6 years (at 15 min)

Working temperature:

-25 to +60°C

Storage temperature:

-30 to +70°C

Interface:

EASYBus-interface
3-pin mini-integral plug.

Needed connection-cable EBSK01 not included in delivery (see accessories page 93)

Housing:

48,5 x 48,5 x 35,5 mm (L x B x H)
(with elbow-plug: 48,5 x 48,5 x 35,5 mm), splash water-proof IP65

Electric connection: (for input signals)

... **40NS W:** elbow-plug in accordance with EN 175301-803/A for connection to an existing transmitter.

... **40NS K:** approx. 0.5 m connection cable

Noise immunity (EMC): the **EASYLOG** have been manufactured in accordance with the regulations concerning EMC (2004/108/EG). The device meets EN 61326-1 (table 2, class B)

additional error: < 0,5%

Options (for extra charge)

- DBK: double battery capacity

recommended for high measure-rates

- ALARM: additional alarm-output

open-collector output via 4-pole miniature mounting connector (IP65) including 1m cable. Max. switching power: 28V, 50mA

Attention: Our software GSOFT40K as well as a level converter (EBW1, EBW3, EBW64 or EB2000MC) are required for all EASYLog devices for configuration and to read-out logger data. (p.r.t. p. 89 a. 92)

STATE-LOGGER

for state monitoring etc.

E.A.S.Y.Bus
- Modul



STATE DATA LOGGER
(48000 meas. values) for individual use

EASYLog 40BIN

Specification

Input signal: passive volt-free switching contact

(input is not isolated for EASYBus)

Measuring values:

1 = contact is closed (R < 50 Ohm)

0 = contact is open (R > 20 kOhm)

Cycle: 2 sec. to 5 h,
free programmable via
software GSOFT 40K

Resolution display and memory: 1 digit

Display: 10 mm high LCD-display

Recording interval: equal to cycle

Storage capacity: 48.000 measuring values

Recording time: 500 days,
(if recording interval is 15 min.)

Battery service life: approx. 6 years (without
switching current, at 15 min)

Working temperature: -25 to +60°C

Storage temperature: -30 to +70°C

Interface: EASYBus-interface
3-pin mini-integral plug.

Needed connection-cable EBSK01 not included
in delivery (see accessories page 93)

*Note: With an according interface converter
you can connect 120 logger without having any
problems.*

Housing: 48,5 x 48,5 x 35,5 mm (L x B x H)
plug and cable not included, IP65

Electric connection: (for input signals)
approx.. 0.5m connection cable, flying leads

Noise immunity (EMC): the **EASYLog** have
been manufactured in accordance with the regu-
lations concerning EMC (2004/108/EG).

The device meets EN 61326-1 (table 2, class B)
additional error: < 0,5%

Options (for extra charge)

- **DBK: double battery capacity**
recommended for high measure-rates

- **ALARM: additional alarm-output**
open-collector output via 4-pole miniature
mounting connector (IP65) including 1m cable.
Max. switching power: 28V, 50mA

HUMIDITY-/TEMPERATURE-/AIR PRESSURE LOGGER

for climate monitoring etc.

E.A.S.Y.Bus
- Modul



HUMIDITY - / TEMPERATURE - / PRESSURE - DATA LOGGER
(each 250.000 measured values) for climatic applications.

EASYLog 80CL

WPF4 - Certificate of calibration humidity (measuring points: approx. 20/40/60/80%)

WPD5 - Certificate of calibration pressure (measuring points 300/500/700/900/1100 hPa)

General

The **EASYLog 80CL** can be configured, started and stopped by its buttons. It is possible to record max. 64 recording sequences (=start/stop processes) with max. 250.000 data sets (humidity/temperature/air pressure).

The device can also be configured and handled by the comfortable software GSOFT40K. There is the possibility to block the stopping of the logger by the buttons to protect the logger of unauthorised handling.

The device supports the display of units relevant for the air conditioning technology: wet bulb temperature, dew point temperature, enthalpy, atmospheric humidity or absolute humidity.

The **EASYLog 80CL** provides a big variety of additional functions:

- SeaLevel correction: instead of the barometric air pressure the pressure at sea level can be display (input of height above sea level needed).

- Min-/max- value memory: callable by the buttons, the highest and lowest value since the start (or reset) of the logger is saved here.

- Min-/max- alarm function: the exceeding of adjustable min-/max- alarm boundaries by the displayed value is monitored. Optional: alarm output for alarm message of the logger available!

Specification

Measuring range, Display ranges:

Humidity: 0,0 ... 100,0 %RH

Temperature: -25,0 ... +60,0 °C

Air pressure: 300,0 ... 1100,0 hPa

Additional available display ranges:

Wet bulb temperature: -27,0 ... 60,0 °C

Dewpoint temperature: -40,0 ... 60,0 °C

Enthalpy: -25,0 ... 999,9 kJ/kg

Atmospheric humidity: -0,0 ... 640,0 g/kg

Absolute humidity: 0,0 ... 200,0 g/cm³

Resolution display and memory:

0.1 °C, 0.1 %RH and 0.1 hPa or 1 digit

Accuracy:

Humidity: ± 2 % in range 10-90%

Temperature: ± 0,3 °C ± 0.017 * (T - 25°C)

Air pressure: ± 1.0 hPa (typ., at 0 - 60°C)

Sensoren:

Humidity/Temp.: sensor mounted in sensor tube
(sensor is exchangeable)

Air pressure: sensor integrated in housing

Sensor tube: Ø15 mm made of polyamide

Protection cap: screw-type plastic protection
cap for quick responses

Display: two 4½-digit LC-displays

Recording interval: 4 sec. to 5 h

free programmable via buttons on the device or
via the software GSOFT 40K

Storage capacity: 250.000 data sets (humidity,
temperature, air pressure)
in max. 64 recording sequences

Recording time: 7 years (at 15 min. interval)

Battery service life: approx. 5 years (at 15 min)

Working temperature: -25 to +60°C

Storage temperature: -30 to +70°C

Interface: EASYBus-interface

3-pin mini-integral plug.

Needed connection-cable EBSK01 not included
in delivery (see accessories page 93)

*Note: With an according interface converter
you can connect 60 logger without having any
problems.*

Housing: 48,5 x 48,5 x 35,5 mm (H x W x D)
sensor and plug not included.

Housing made of shock resistant
plastic, transparent front made of
polycarbonate, splash water-proof:
IP 65 (excl. protection cap)

Noise immunity (EMC): the **EASYLog** have
been manufactured in accordance with the regu-
lations concerning EMC (2004/108/EG).

The device meets EN 61326-1 (table 2, class B)
additional error: < 0,5%

Options (for extra charge)

- **ALARM: additional alarm-output**
open-collector output via 4-pole miniature
mounting connector (IP65) including 1m cable.
Max. switching power: 28V, 50mA

Please Note: For trademark reasons we currently do not deliver members of the **EASYLOG** family to GB and USA. Please order there the constructional identical types: Logger type 40K, Logger type 40RF, ...

E.A.S.Y.Bus® System

Principle overview

Characteristics of the EASYBus system

- Low-cost wiring by using a twisted 2-pin connection line in either bus or tree design (polarity-free); can be used in any combination
- Bus line for simultaneous power supply and signal transmission
- Bus length up to 1000 m, extensible by using a repeater
- Fully automatic start-up installation via software
- Sensor modules can be changed, removed or added during operation at any time
- Connection of up to 240 sensor modules
- Optimum transmission reliability by means of CRC check
- Bus system is able to process data up to 20 measuring values per second
- Response time inside the EASYBus system ca. 1 sec.; but approx. 20 ms by using a local controlling system

The EASYBus hardware

- 2-pin connection line, based on the principle of the »M-Bus«
- Polarity-free bus connection
- Bus system voltage 36 V DC, minimum 24 V DC
- Maximum allowable bus power loss: 12 V DC
- Master/slave system; data transmission of the slaves only on demand



Temperature monitoring and regulation:
Cooling chambers
Laboratory + utility rooms
Storage rooms



Relative humidity / dew point / temperature monitoring:
Storage rooms
Heating systems / air condition
Museums / exhibition rooms
Libraries
Laboratories/utility rooms



Relative humidity / atmospheric pressure, CO₂ monitoring:
Manufacturing rooms / storage rooms
Office rooms (to condition the air of the room)
Greenhouses



CO monitoring:
Underground garages / Parking garages
Motorcar garage / car repair
Indoor go-kart tracks

Schnittstellen-Konverter

Zentrale Datenerfassung

Sensormodule mit Messwertspeicher (Logger-Funktion)

Sensormodule ohne Messwertspeicher

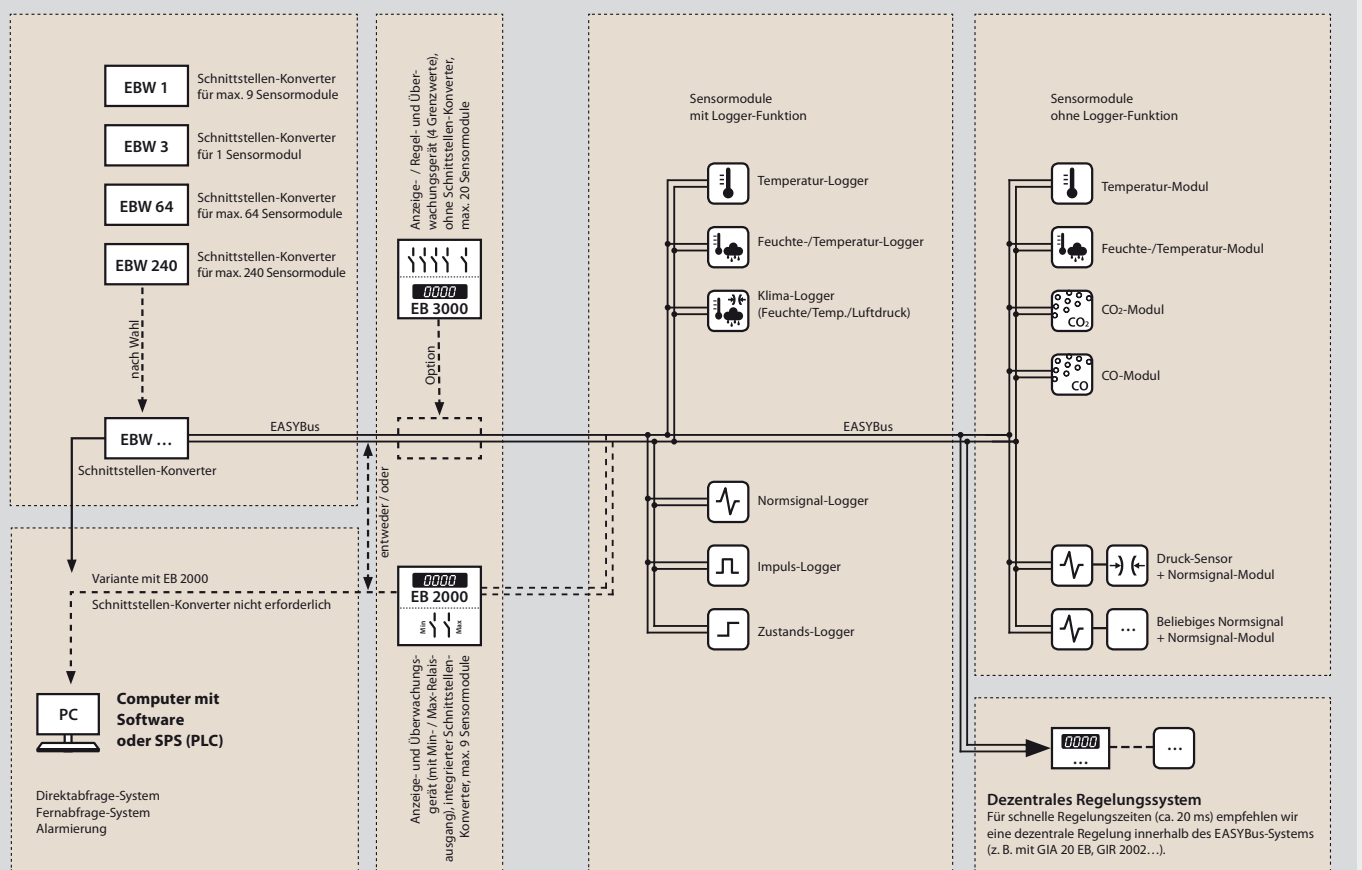

EASYBus - sensor modules for humidity/temperature

EBHT - 2R

- VO: Option "On-site display"
- HO: Option "High-humidity sensor (0...100%)", incl. "encapsulated PCB"
- UNI: Option "selectable humidity display unit"

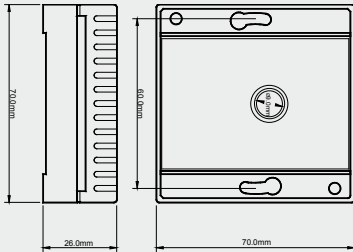

E.A.S.Y. Bus
- Modul



Specification

Measuring range:

Humidity: 0.0 ... 100.0 %RH
recommended range (standard): 30 ... 80 %RH
recommended range (option -HO): 5 ... 95 %RH
Temperature: -25,0 ... 70,0°C or -13,0 ... 158,0°F

Display options: refer to below

Resolution: 0,1 %RH or 0,1°C / 0,1°F

Accuracy: (at nominal temperature = 25°C)

Humidity: ±2.5 %RH (at recommended range)

Temperature: ±0.4 % of meas. value ±0.3°C

Electric connection: 2 pin screw-type terminal, no polarity, max. 1,5mm²

Ambient temperature: -25...50°C

Housing: 70 x 70 x 26 mm (L x B x H)

Option Display: 10mm high LCD-display

EBHT - 1R (sensor tube at the side, FL = 50 mm)

EBHT - 1K (sensor tube at the side, FL = 220 mm)

EBHT - 2K (sensor tube pointing downwards, FL = 220 mm)

- VO: Option "On-site display"
- HO: Option "High-humidity sensor (0...100%)"
- UNI: Option "selectable humidity display unit"
- LACK: Option "Encapsulated PC-board"
- FL300, FL400, FL500: Option "Longer probe tube"
- KABEL: Option "separated sensor tube", incl. option high-humidity sensor
Sensor head (Ø14 x 68 mm) connected to housing via approx. 1m teflon cable.
- SHUT: Option "Heat-absorption hat / weather protection shield"
Avoids falsification of meas. data due to sun/Rain etc - p.r.t. page 104

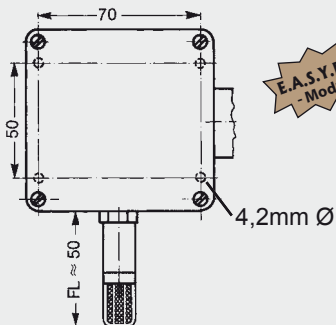

E.A.S.Y. Bus
- Modul

EBHT - 1R
incl. option VO



Specification

Measuring range:

Humidity: 0.0 ... 100.0 %RH
recommended range (standard): 30 ... 80 %RH
recommended range (option -HO): 5 ... 95 %RH
Temperature: -40,0 ... 120,0°C or -40,0 ... 248,0°F

Display options: with option UNI an alternative display unit can be shown instead of the humidity measuring value. The unit selection will be done via the interface or at the keyboard (by option VO).

Wet bulb temperature: -27,0 ... 60,0 °C

Dewpoint temperature: -40,0 ... 60,0 °C

Enthalpy: -25,0 ... 999,9 kJ/kg

Atmospheric humidity: 0,0 ... 640,0 g/kg

absolute humidity: 0,0 ... 200,0 g/m³

Resolution: 0,1 %RH or 0,1°C / 0,1°F

Accuracy: (at nominal temperature = 25°C)

Humidity: ±2.5 %RH (at recommended range)

Temperature: ±0.4 % of meas. value ±0.2°C

Electric connection: elbow-type plug EN 175301-803/A (IP65), output 2-wire connection, max. 1,5mm² each, no polarity

Ambient temperature:

electronic, housing: -25...50°C

sensor (sensor tube): -40...100°C (for short time up to 120°C)

Housing: 82 x 80 x 55 (L x B x H),

material: ABS, IP rating: IP65

Sensor tube: tube-Ø 14mm, screwable

protection cap with stainless

steel gauze (105 µm).

Total length approx 50 mm or

220 mm (standard)

Optional extended length 300, 400 or 500 mm available. (please specify upon order!)

Option Display: 10mm high LCD-display

The option VO additionally

has 3 pushbuttons for calling

min./max. values and adjust-

ment of measuring parameters

(offset and scale correction).

For outdoor use:

Option "encapsulated PC board" required. We also recommend using a heat absorption hat (weather protection shield) to avoid falsification of measuring data due to sun/rain etc. (p.r.t. page 104)

Other types upon request !

Spare parts

Spare protection cap

with stainless steel gauze (105µ mesh size)
- for standard and high humidity use

Bronze filter

(not for use in high humidity use)

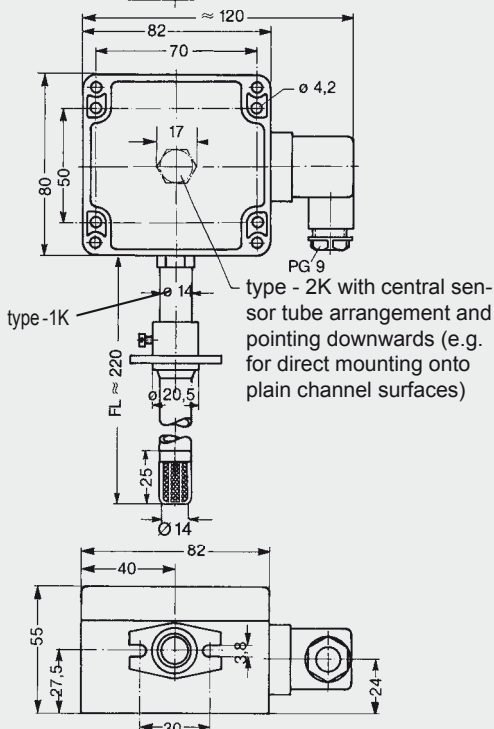

EBHT - 2K



EASYBus - sensor modules for temperature

EBT - 2R

EBT - 2RE with external sensor for lower or higher temperatures. Sensor: like GTF2000LE on page 122 of catalogue

-VO: Option "On-site display"

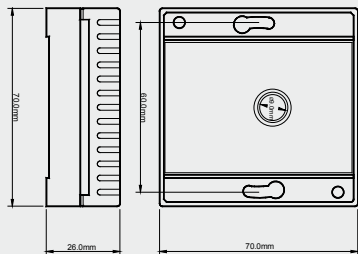

Specification

Measuring range:

EBT - 2R: -25,0 ... 70,0 °C or -13,0 ... 158,0 °F
EBT - 2RE: -50,0 ... 150,0 °C or -58,0 ... 302,0 °F
Resolution: 0,1 °C / 0,1 °F
Accuracy: ±0.4% of meas. value ±0.3°C (at nominal temperature = 25°C)

Sensor element: Pt1000 acc. to DIN IEC 751
Electric connection: 2 pin screw-type terminal, no polarity, max. 1,5mm²
Ambient temperature: -25...50°C (electronic)
Housing: stream-lined housing for indoor installation (can be directly mounted on flush-type sockets)

Dimensions: 70 x 70 x 26 mm (H x W x D)
Sensor (EBT-2RE): V4A-can, 5mm Ø, 50mm long, approx. 1m silicone cable
Option Display: 10 mm high LCD-display

- EBT - AP1** (measuring range: -50,0 ... +150,0°C) * as of
- EBT - AP2** (measuring range: -50,0 ... +400,0°C) * as of
- EBT - AP3** (measuring range: -50,0 ... +150,0°C) * as of
- EBT - AP4** (measuring range: -50,0 ... +150,0°C) * as of
- EBT - AP5** (measuring range: -199,9 ... +650,0°C) * as of



* observe necessary order information!

- VO: Option "On-site display" (LCD with 10 mm high digits)
- LACK: Option "Encapsulated PC-board" (for outdoor use)
- FL... (Longer probe tube); -HL... (longer collar tube):
Price incl. up to 100 mm, extended length: price per 100 mm

Specification

Measuring range:

- AP1, AP3, AP4: -50,0 ... 150,0 °C or -58,0 ... 302,0 °F
- AP2: -50,0 ... 400,0 °C or -58,0 ... 752,0 °F
- AP5: -199,9 ... 650,0 °C or -199,9 ... 999,9 °F

Sensor element: Resistance thermometer Pt1000 acc. to DIN IEC 751
Resolution: 0,1 °C / 0,1 °F

Accuracy (electronic): (at nominal temperature = 25°C) ±0.2% of meas. value ±0.2°C

Sensor accuracy: (Pt1000)
 Standard: acc. to DIN KI.B (±0,3°C at 0°C)
 Option: 1/3 DIN: ±0,1°C at 0°C (upcharge p.r.t. page 121)

Electric connection: elbow-type plug EN 175301-803/A (IP65), output 2-wire connection, max. 1,5mm² each, no polarity

Sensor connection: 2-wire connection available (e.g. EBT - AP5)

Ambient temperature (electronic): 0...70°C
Temperature coefficient: 0,05%/°C
Storage temperature: -20...+70°C

Housing: 82 x 80 x 55 (L x B x H), material: ABS, IP rating: IP65

Mounting position: any
Fixing: by means of screw-thread or fixing holes in the housing (accessible after top cover has been removed).

Mounting distance: 50 x 70mm
Fixing screws: max. shaft Ø: 4mm
Sensor mounting: sensors are electrically insulated as a standard.

Thread sizes "G": 1/2" (standard) material V4A G1/4", G3/8", G1/2", M5, M6, M8, M10, M12, other threads upon request!

Sensor tube: „D“: 3 mm, 4mm, 5 mm, 6 mm and 8 mm - material: V4A
Collar tube: HL = please specify length desired (for ...-AP2 only) (V4A-tube)

Option Display: 10 mm high LCD-display
 The option VO additionally has 3 push-buttons for calling min./max. values and adjustment of measuring parameters (offset and scale correction).

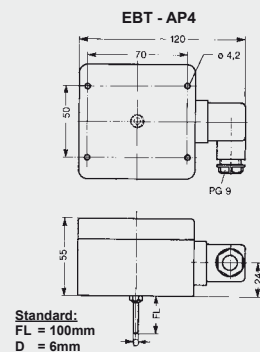
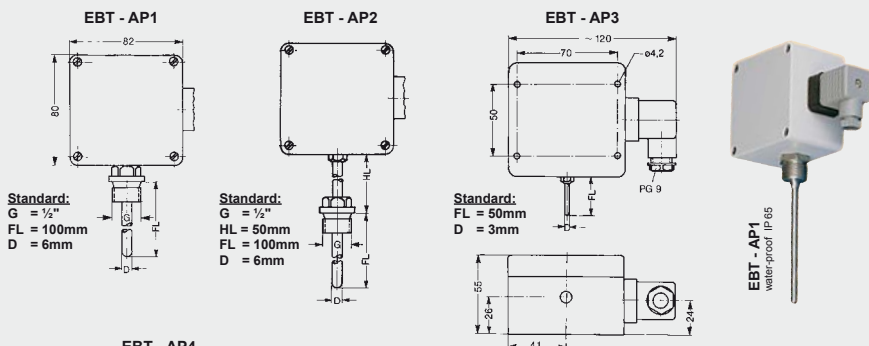

Design types

- Design 1:** With threaded pin „G“ for direct screw connection.
- Design 2:** For higher temperatures, threaded pin „G“ at a distance from housing. HL = collar tube length.
- Design 3:** Indoor or outdoor probe for direct wall mounting (encapsulation of electronics required for outdoor use).
- Design 4:** Duct-type probe with probe tube arranged centrally and pointing downwards.
- Design 5:** Transducer for existing Pt1000 sensors or for applications where probe and housing need to be separated (e.g. extremely high ambient temperature or due to design reasons).

Other design types upon request - please do not hesitate to contact us !

Ordering information

- ! at least necessary:
Type, sensor element and type specific sensor tube data:
● "FL" and "D" (AP1 - AP4), "G" (AP1, AP2), "HL" (AP2).

Ordering examples: all data to be mentioned in any case!

- EBT - AP1, G = 1/2", FL = 100 mm, D = 6 mm
- EBT - AP3, FL = 50 mm, D = 3 mm
- EBT - AP5

EASYBus - sensor modules for temperature

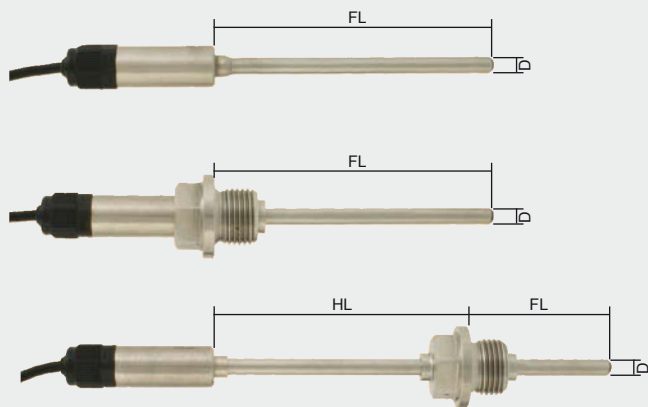

EBT - IF1

EBT - IF2

EBT - IF3



Specification

Meas. range: *The probe length FL has to be chosen long enough, that the allowable temperature range of the electronics situated in the tube sleeve is not exceeded.*

EBT - IF1 (standard): -30,0 ... +100,0 °C

EBT - IF2 (standard): -30,0 ... +100,0 °C

EBT - IF3 (standard): -70,0 ... +400,0 °C

other measuring ranges (max. -200 ... +500°C) *upon request*

Meas. probe: internal Pt1000-sensor

Accuracy: (at nominal temperature = 25°C)

Electronic: ±0.2 % of meas. value ±0.2 °C

Measuring probe: standard: DIN class B
optionally higher sensor accuracy available

Interface: EASYBus-interface
attached 2-pole cable, cable-length approx. 1m.
For direct connection to a converter or to the EASYBus.

Operating ambient of electronics (in tube sleeve):

working temperature: -25 to 70 °C

relative air humidity: 0 to 100 %RH

Housing: stainless steel housing

Dimensions: depending on sensor construction

tube sleeve: Ø15 x 35 mm (without screwing)

tube length FL: 100 or 50 mm *or on customer requirement*

tube diameter D: Ø 6 mm *or on customer requirement*
(available Ø: 4, 5, 6 and 8 mm)

collar tube length HL: 100 mm *or on customer requirement*

thread: G1/2" *or on customer requirement*
(available threads M8x1, M10x1, M14x1.5, G1/8", G1/4", G3/8", G3/4")

Min-/max-value memory: the min-/max-value will be stored

Adjusting: via interface by means of offset and scale values

Options / upcharges

- FL=...: longer tube, *each started further 100mm*
- HL=...: longer collar tube, *each started further 100mm*
- D=...: other tube diameter *without upcharge*
- G=...: other thread *upon request*

EASYBus - sensor modules for standardized signals



EBN / W - ...
with elbow-type plug

EBN / K - ...
with connection cable

EBN / K - ...¹⁾EBN / W - ...¹⁾

¹⁾ - Please specify desired standardized signal upon order: (e.g. EBN / K - 0..10V)

General

All standard signals (0-2V, 0-10V, 0-20mA, 4-20mA, others on request) can be acquired on the EASYBus with its current module. When using a according interface converter on the EASYControl net software different transmitters can be connected resp. watched.

Specification

Input signal: => *specify desired type upon order*
0...2V, 0...10V, 0...20mA or 4...20mA.
(input is not isolated for EASYBus)

Measuring range: -1999 to 9999 Digit,
Measuring range and decimal point can be set via EBxKonfig software. (available free on our homepage).

Accuracy: ± 0.5 % (at nominal temperature)

Working temperature: -25 to +60 °C

Storage temperature: -30 to +70 °C

Interface: EASYBus-interface
attached 2-pole cable, cable-length approx. 1m.
For direct connection to a converter or to the EASYBus.

Housing: 48,5 x 48,5 x 35,5 mm (H x W x D)
(with elbow-type plug: 50,5 x 90 x 39,5 mm),
splash-water proof IP65

Electric connection: (for input signals)
- EBN / K -: for connection to standardized signal source via 0.5 m connection cable.

- EBN / W -: elbow-type plug according to EN 175301-803/A for plug-in into an existing transmitter connection.

Options / upcharges

VO: On-site display

EASYBus - sensor modul for carbon monoxide (CO)

E.A.S.Y. Bus
- Modul



EBG - CO - 1R

Properties

High quality CO transmitter for detection of carbon monoxide in underground garages, parking garages, boiler plants, heating systems, garages as well as in the ambient air.

The CO sensor module has a very long-lasting electrochemical measuring cell and could be easily installed.

Range of Application:

- underground garages, parking garages
- boiler plant and heating systems
- motorcar garage

Highlights:

- long-lasting electrochemical measuring cell
- automatic zero calibration
- 3 years warranty for the co sensor element

Specification

Measuring range:	0 ... 300 ppm CO (carbon monoxide)
Measuring principle:	electrochemical, permanent measuring
Reproducibility:	< 3 ppm according to VDI 2053
Response Time T₉₀:	< 60 s
Cross sensitivity:	≤ 2% of 300 ppm CO (acc. to VDI 2053)
Linearity error:	≤ 2% of 300 ppm CO (acc. to VDI 2053)
Offset adjustment:	automatically
Interface:	EASYBus-interface
Auxiliary energy:	14 ... 30 V DC, max. 50 mA
Working condition:	-10 ... +40 °C, 15 ... 95 %RH (non-condensing)
Option: on site display	3½-digit LC-display
EMC:	according to EN 50 081-1, EN 50 082-2 B
Electric connection:	elbow-type plug acc. to EN 175301-803/A (IP65), max. wire cross section: 1.5 mm ² , wire diameter from 4.5 to 7 mm
Housing:	ABS, 82 x 80 x 55 mm (without elbow-type plug)
Mounting:	with fixing holes for wall mounting
Mounting distance:	70 x 50 mm (W x H)
Fixing screws:	max. shaft-Ø
Weight:	approx. 200 g

Options / upcharge

VO: on site display

Accessories

GZ-01	test gas cap GT (for controlled flow with test gas)
GZ-02	gas bottle with 12l test gas: 30 ppm CO
GZ-03	gas bottle with 12l test gas: 300 ppm CO
GZ-04	gas valve unit MiniFlo for gas bottles with 12l
GSN 24	plug-in power supply (230V _{AC} => 24V _{DC} /300mA)

additional accessories upon request

EASYBus - sensor modul for carbon dioxide (CO₂)

E.A.S.Y. Bus
- Modul



EBG - CO2 - 1R

Properties

Due to the fact, that CO₂ is an important indicator for the quality of air in rooms, it's super important to measure the CO₂ content.

The recommended CO₂ limit value for ambient air is 1000 ppm. An exceeding of this limit causes tiredness and a loss of concentration.

The high quality and precise CO₂-module works according to the infrared principle (NDIR). An auto-calibration procedure compensates aging effects and is responsible for an excellent long term stability of this CO₂-module.

Additionally, there is a local display which shows beside the actual CO₂ concentration, the minimum and maximum values as well as an optical alarm.

Highlights:

- auto-calibration procedure
- auto-calibration procedure
- for surveillance of the recommended CO₂ concentration in ambient air

Specification

Meas. range:	standard: 0 ... 2000 ppm CO ₂ (carbon dioxide) opt. /5000: 0 ... 5000 ppm CO ₂ (carbon dioxide)
Measuring principle:	infrared principle (NDIR)
Accuracy:	standard: ±50 ppm ±2 % of meas. value (at 20°C, 1023 mbar) opt. /5000: ±50 ppm ±3 % of meas. value (at 20°C, 1023 mbar)
Interface:	EASYBus-interface
Auxiliary energy:	12 ... 30 V DC, max. 600 mA
Display:	approx. 10 mm high, 4-digit LC-display
Working condition:	-10 ... +50 °C, 5 ... 95 %RH, 850 ... 1100 hPa
Storage condition:	-25 ... +60 °C, 5 ... 95 %RH, 700 ... 1100 hPa
Electric connection:	elbow-type plug acc. to EN 175301-803/A (IP65), max. wire cross section: 1.5mm ² , wire diameter from 4.5 to 7 mm
Terminal assignment:	2 x EASYBus, no polarity 2 x Auxiliary energy
Housing:	ABS, 82 x 80 x 55 mm (without elbow-type plug)
Mounting:	with fixing holes for wall mounting
Mounting distance:	70 x 50 mm (W x H)
Fixing screws:	max. shaft-Ø 4 mm
Weight:	approx. 225 g
Features:	- min-/max-value memory, - optical alarm, - input of offset and scale for adjusting

Options / upcharges

5000: measuring range: 0 ... 5000 ppm CO₂

Accessories

GSN 24-750 plug-in power supply (230V_{AC} => 24V_{DC}/750mA)

EASYBus-display and monitoring device for 20 channels

Front
48 x 96

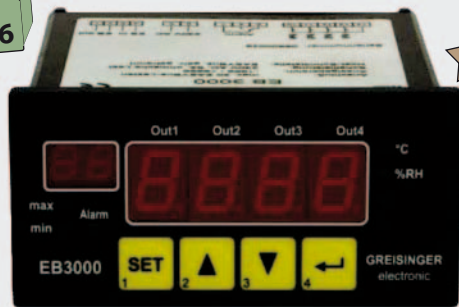

E.A.S.Y.Bus
-Modul

EB 3000

- Up to 20 sensor-modules or loggers can be connected
- Sensor module supply and data transfer are carried out via one single 2-wire line
- 5 relay outputs (4 x controlling, 1 x alarm)
- Controller functions can be assigned to any channel, e.g.:
 - 4 x two-point-controllers (of 4 sensors)
 - 2 x three-point-controllers (of 2 sensors)
 - 4-way switch (of 1 sensor), ...
- 2 further functions / calculations:
 - average value over more sensors
 - difference of 2 sensors
 - special functions (upon request)
- Alarm monitoring for all connected EASYBus-moduls
- easy configuration via front-side keypad or via interface
- Via serial interface the connected devices can be read or additionally be monitored with a PC.
- Up to 1000m cable-length possible
- Additional connection of a second EB3000 for enlargement

Specification

- Display range:** -1999 to +9999 digit
Resolution: depending on sensor module used
Accuracy: depending on sensor module used.
Sensor modules: all intelligent EASYBus sensor modules
Sensor supply: via EB 3000
max. bus load: 30 EASYBus standard loads
meas. channels: 20
perm. cable length: 500 m (depending on type of cable and wiring)
Switching outputs: 4 relay outputs (NO), shared input. Outputs can be as signed to any channel
Switching power: 230VAC, 5A, ohm resistive load
Switching function: 2-point controller, 2-point controller inverting
 Switching points and delay for each output freely selectable
Alarm output: 1 relay output (change-over contacts)
Switching power: 230VAC, 5A, ohm resistive load
Alarm function: Common alarm for all sensors.
Configuration: directly on the device or via additional configuration software (supported converter is needed).
Min./Max. value memory: from all connected sensor modules the Max. and Min. value are callable via front-side keypad.
Calculation-functions: there are 2 "virtual" channels additionally to the sensor-channels. A calculated value can be displayed here. Possible calculation functions: sensor-deviation, averaging above x sensors, etc.
Self diagnosis: permanent self-diagnosis, diagnosis of all connected sensor moduls to ensure trouble-free function.
Display: main display: LED, 4-digit, 13mm
 channel display: LED, 2-digit, 7mm
Interface: EASYBus-interface with supported converter (e.g. EBW1) GRS232 compatible, for communication with a PC.

Housing: 48 x 96 x 100 mm (H x W x D)

Panel cutout: 43 x 90,5 mm (H x W)

Front: Transparent membrane keyboard IP65. Sealing for housing for installation according to IP65 will have to be ordered separately.

Connection: 2-wire connection in ring-, tree- or star type. No polarity.

Connection terminals: screw-type/plug-in terminals

Ambient temperature: -25 to 50°C (permissible ambient temperature)

Voltage supply: 230V AC 50/60 Hz

Power consumption: approx. 9 VA

EB 3000 FTR

Set for Moisture / Temperature Controlling

Scope of Supply:

EB 3000: monitoring and controlling device (p.r.t. page 88)

EBHT - 1R: temperature / humidity modul (p.r.t. page 84)

VSL2P: 10 m twisted pair cable (p.r.t. page 93)

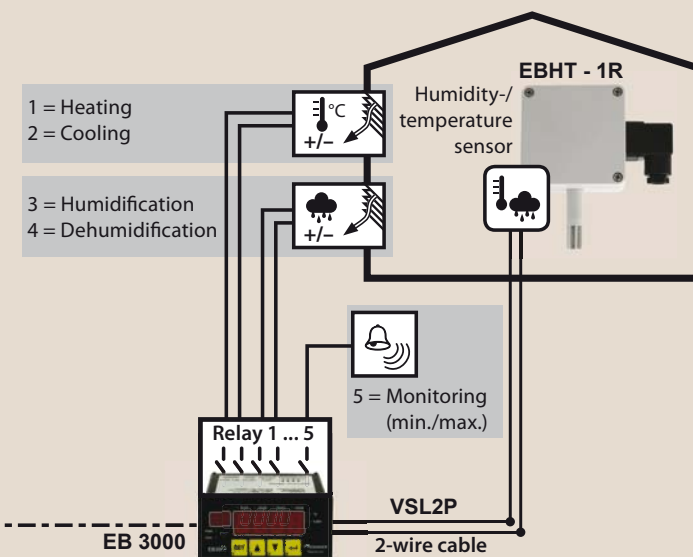

Cost effective monitoring and controlling of temperature and humidity. The humidity- / temperature sensor EBHT-1R will be connected with the EB 3000 via a single 2-wire twisted pair cable (e.g. bell wire). The maximum distance between sensor and controlling device is 500 m.

Range of application:

Refrigeration warehouse, green house, storage room, terrarium, etc.

Advantages:

- Simple installation and polarity free 2-wire system
- 4 switching outputs (humidify, dehumidify, heating, cooling) and 1 alarm output
- Easy upgrade to 20 single sensors (temperature, humidity, standard signals etc.)
- Excellent cost-performance-ratio

Note:

For configuration of the EB 3000 and recording / reading of connected EASYBus modules, a serial converter EBW 1 is needed.

Accessories

EBW 1 serial converter EASYBus <=> RS232
further informations p.r.t. p. 92

EBS 20M software for recording and archiving
of max. 20 sensor modules (p.r.t. p. 91)

EASYBus-display and monitoring device for 9 channels

Front
48 x 96



E.A.S.Y. Bus
Modul

EB 2000 MC

- Display and monitor up to 9 sensor modules or loggers.
- automatically detects the number and type of sensor modules connected.
- Sensor module and logger supply as well as data transfer are carried out via one single 2-wire line.
- Monitoring of all sensor and logger functions as well as cable and sensor damage etc.
- 2 volt-free relay outputs for separate min./max. alarm.
- RS232-interface ensures easy configuration
- The EB 2000 MC can be used as a interface converter RS232 - EASYBus so that all EASYBus-moduls connected can be read and configured via the EB 2000 MC.

Specification

- Measuring range:** -1999 to +9999 digit
- Resolution:** depending on sensor module used.
- Accuracy:** depending on sensor module used.
- Sensor modules:** all intelligent EASYBus sensor modules as well as **EASYLog** (max. 9) can be connected. 2-wire connection in ring-, tree- or star type. No polarity, max. cable length: 200m.
- Sensor supply:** via EB 2000 MC.
- Fault messages:** sensor damage, sensor short circuit, values above/below permissible area.
- Self diagnosis:** const. monitoring to ensure trouble-free function.
- Interface:** RS232 for easy configuration, or as interface converter RS232 - EASYBus.
- Min./Max. value memory:** for up to 9 different sensor modules, selectable via front side keyboard.
- Min./Max. alarm:** 2 volt-free relays (make contact), 10A (ohmic load), 250V, 50/60Hz, for min./max. alarm, programmable via front side button or RS232-interface.
- Alarm delay:** from 0 to 9999 minutes, can be set individually for each channel.
- Display:** 4-digit, red, 13mm high LED-display. 16 additional LEDs for display and monitoring functions.
- Front:** Transparent membrane keyboard IP65. Sealing GGD 4896 for housing for installation according to IP65 will have to be ordered separately.
- Housing:** rack-type housing, 48 x 96 x 100mm (H x W x D).
- Panel cutout:** 43 x 90,5 mm (H x W).
- Connection terminals:** screw-type/plug-in terminals
- Ambient temperature:** 0 to 50°C
- Voltage supply:** 230V AC 50/60Hz (standard)
- Power consumption:** approx. 3,5 VA

Options / upcharges

- **Voltage supply:** 12V AC, 24V AC or 115V AC 50/60Hz (others upon request)

EB 3000 / EB 2000 MC cost savings in all areas !

- short installation time - only one 2-pin line.
- polarity must not be observed by installation
- minimum material requirement - only one display and monitoring device for up to 9 / 20 sensor modules
- minimum time requirement for planning and commissioning - automatic sensor module detection, expandable for up to 9 / 20 sensor modules of any type.



Accessories

APG-4

surface-mounted housing (incl. sealing)

GGD 4896

add. sealing for panel mounting acc. to IP65

GRS 01/9

interface adapter RS232: (adapter cable to 9-pin PC-interface)
(Please note: order Dsub9 -> Dsub25, if required! - GSA 9S-25B)

EBW 1

interface converter: EASYBus to RS232

EBSK 01

connection cable 1m, for **EASYLOG**, EBN

EBSK 03

connection cable 3m, for **EASYLOG**, EBN

VSL 2P

per m

twisted special cable for **EASYBUS**-system, cross section 2 x 0,75 mm²

AKL 1P

special-branch terminal or connection to VSL2P, 2 pieces

EASYBus-Configurator

software for comfortable editing of all EB3000-parameters. (downloadable from our homepage: Service --> Download)

Sensor, logger modules

p.r.t. page 79 - 87

for temperature, humidity, norm. signal, frequency, ...

GSOFT 40K (incl. connection cable EBSK01)

Operating software for EASYLog and T-Logg datalogger

GSOFT40K is the comfortable operation software for the very easy operation of the **EASYLog's** and **T-Logg's**. The software supports English, German and Czech language and is executable with Windows 98, Me, NT, 2000, XP, Vista and 7.

Comfortable user interface - the essentials on a glance:

The programme is menu driven, the most important commands are additionally available in a toolbar. Whenever necessary the software gives hints and messages. Therefore any user with a few basics about how to operate standard Windows software will be able to operate it. Loggers can be connected, started and read out by single mouseclicks.

Display of logger state informations

All necessary informations are compressed to a single clearly arranged window for each connected logger.

Setting of special functions

The loggers are supporting alarm functionality - easily configurable by the GSOFT 40K Software. All other important logger settings are displayed, too. E.g. a label up to 16 characters long can be assigned to each logger channel, which is stored in the logger. You may for example label the location or other useful details by using this function.

Additional entering of remarks

If You have read out a logger and want to store the data on disk or harddisk there is the possibility to additionally enter remarks of any length for each recording, for example to describe and comment unusual occurrences during the recording.

The screenshot shows the GSOFT 40K software interface. The main window displays configuration for two loggers: '05200149 EASYLOG 24RFT' and '05200079 EASYLOG 24RFT'. The left window shows the configuration for the first logger, including a table of measurement values and a section for 'Loggeraufzeichnung läuft' (Logger recording running) with details like 'Logger-Zeit', 'Intervall', and 'Speicher'. The right window shows the configuration for the second logger, including a table of measurement values and a section for 'Alarm' settings.

Bezeichnung	05200149 EASYLOG 24RFT	05200079 EASYLOG 24RFT
Meßwert	22,5 °C	38,9 % r.F.
Meldung	ok	ok

Bezeichnung	Labor-Temperatur	Labor-Feuchte
EASYBUS-Adresse	1	2
Anzeigebereich	-25,0...60,0 °C	0,0...100,0 % r.F.
Meßart	Temperatur	rel. Luftfeuchtigkeit
Alarm Min	-25,0 °C	0,0 % r.F.
Alarm Max	60,0 °C	100,0 % r.F.
Alarm Verzögerung	0 min	0 min

The screenshot shows the GSOFT 40K software interface displaying a data table and a line graph. The table shows data for 'Labor-Temperatur' and 'Labor-Feuchte' over time. The graph shows the data for 'Labor-Temperatur' and 'Labor-Feuchte' over time, with a zoomed-in view of a specific section.

nr	Datum	Zeit	Labor-Temperatur	Labor-Feuchte
1	13.9.2000	16:06:05	26,6	52,1
2	13.9.2000	16:06:39	26,6	52,1
3	13.9.2000	16:07:09	26,6	52,2
4	13.9.2000	16:07:39	26,6	52,2
5	13.9.2000	16:08:09	26,6	51,6
6	13.9.2000	16:08:39	26,6	51,6
7	13.9.2000	16:09:09	26,6	51,4
8	13.9.2000	16:09:39	26,6	51,2
9	13.9.2000	16:10:09	26,7	51,2
10	13.9.2000	16:10:39	26,7	51,2
11	13.9.2000	16:11:09	26,7	51,3
12	13.9.2000	16:11:39	26,7	51,5
13	13.9.2000	16:12:09	26,7	51,6
14	13.9.2000	16:12:39	26,7	51,4
15	13.9.2000	16:13:09	26,7	51,6
16	13.9.2000	16:13:39	26,7	51,7
17	13.9.2000	16:14:09	26,7	51,5
18	13.9.2000	16:14:39	26,7	51,2
19	13.9.2000	16:15:09	26,7	51,3
20	13.9.2000	16:15:39	26,8	51,2
21	13.9.2000	16:16:09	26,8	51,3
22	13.9.2000	16:16:39	26,8	51,1

The data: Tables and diagrams

After reading out the recordings the data will be displayed in form of a table. With the diagram the data of several loggers can be displayed simultaneously. Additional diagram functions:

- labelling of measuring values
- real time axis
- zooming of any section within the diagram
- legend (inactivate able)
- measurement cursor (inactivate able)
- marking of measurings with symbols (inactivate able)

The main target of the design of GSOFT40k was most easiest operationability, therefore just a few easy mouseclicks are necessary to display data fast and clear. Both diagrams and tables are displaying the data in realtime, even daylight savings time settings are taken into account automatically. And of course tables and diagrams can be printed out.

E.A.S.Y.Bus & simultaneous operation and display of several loggers

Because of the EASYBus more than one logger can be connected at the same time at a single serial PC interface. Distances of up to 1000 m can be covered. To simplify operation all connected loggers can be operated at the same time. This reduces the expense of operation time and even largest EASYBus-systems can be controlled easily.

Remote operation via conventional and mobile telephone nets

With GSOFT 40K loggers can be operated and read out via any distance by the means of the conventional or the mobile telephone nets. Because of this feature measuring values and recordings can be collected centrally covering distances of hundreds of kilometers. (p.r.t. page 94)

Automated Read Out

All loggers connected directly or via conventional an mobile telephone nets can be read out automatically. The points of time can be entered separately (e.g. each day lor each week ... at X.XX o'clock), the read out data will be archived on hard disk. The system gets even more reliable and the handling of multiple loggers gets much easier.

Export function

To be able to use the logger data with other software applications (EXCEL, WORD,...), a flexible export function is integrated. The data can be converted to textfiles which can be processed by all popular programmes.

Update GSOFT 40K (for registered users with declaration of serial number of original version)

Update can downloaded freely from our homepage (prerequisite: existence version ≥ 7.0)

EASYBus-Configurator free of charge

Software for initial installation and configuration of EASYBus-systems.
Software executable with: Windows 2000, XP, Vista and Windows 7.

- EASYBus modules, display- and controlling-devices can be handled easily and comfortably.
- Listing of all connected modules in a treeview, therefore an easy overview of the system is possible.
- Settings of EASYBus modules can be done clearly.
- Easy installation of the EB3000 control-, display- and monitoring-device:
 - Adding of modules via Drag&Drop.
 - Programming of predefined virtual channel functions (included in software).
 - Switching- and alarm-outputs can be configured easily.

You can download this software from our homepage (www.greisinger.de) for free.

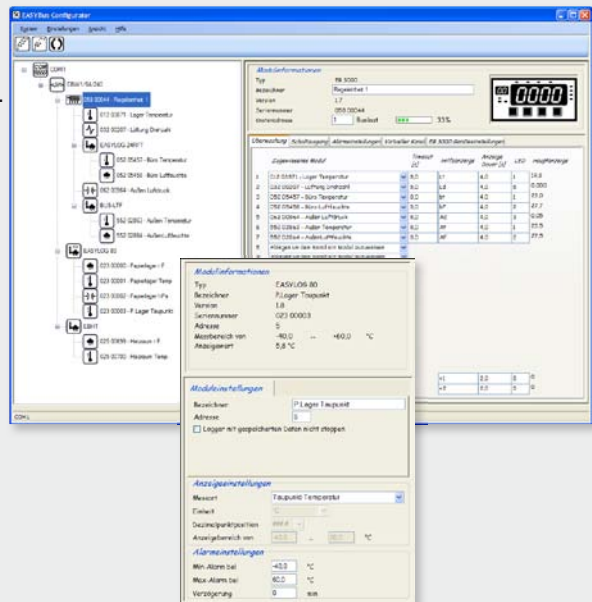

EBS 20M EBS 60M

Software for recording, monitoring and displaying up to 20 / 60 sensor modules. Software executable with: Windows XP / Vista / 7

Highlight:

- Simultaneous use of several serial interfaces
- Simultaneous use of different serial converters
- Quick and easy installation
- Freely scaleable diagrams and alarm limits
- Visualization of actual measurements values
- Trusted data storage via SQL database
- Data export

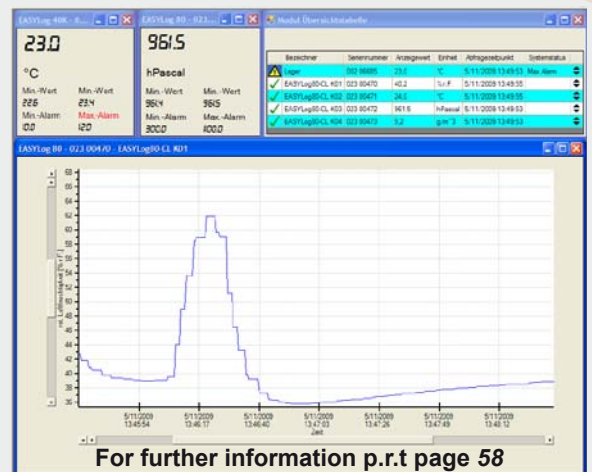

For further information p.r.t page 58

EASYControl net

Software solution for recording, monitoring, displaying and analysing of sensor moduls.

Software is executable with: Microsoft Windows XP / Vista / 7 (32 / 64 Bit)

- » **Trendsetting „one measuring-system is a back number“**
 - Embedding different measuring-systems or measuring-devices via PlugIn
- » **Peripheral**
 - Uncoupling of data acquisition, data storage and visualisation
 - Component communication via LAN
 - Data visualisation by local network
- » **Live**
 - Constantly updating data
 - Accurate time assignment of the data
 - Load ancient data and complete them with „live“ data
- » **Secured**
 - User accounts (with secured password transmission).
 - Stored data can't be modified or manipulated later
- » **Controlled**
 - Trigger EBB Out switching channels via EASYBus

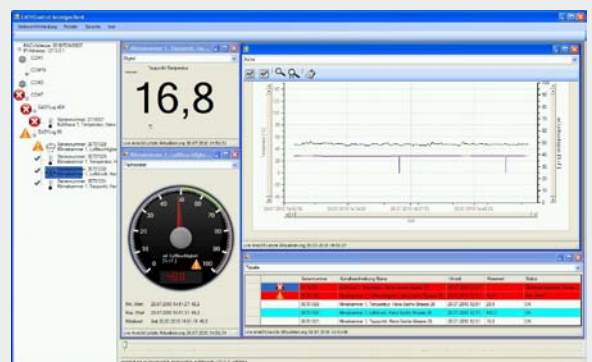

» Clear

- Different kinds of visualisation (table, digital, tachometer, chart)
- Display multiple graphs "live" in one chart
- Tooltips (with status information) for each measuring point in the chart
- Blinking symbols on error or status message in the visualisation
- Displaying error- and status messages.
- Displaying min- max- and mean value of the sensors
- Generate reports and store them as PDF, Excel or Word file

EASYBus - interface converter



EBW 1 interface converter
for connection of max. 9 EASYBus-modules to the RS232-interface (9-pin Dsub) of your PC.
Scope of supply: interface converter, 9-pin Dsub extension cable



EBW 3 interface converter
for connection of one EASYBus-module (e.g. **EASYLOG**) to the USB-interface of your PC. (Power supply: via USB)
Scope of supply: interface converter



EBW 64 interface converter
for connection of max. 64 EASYBus-modules to the RS232-interface of your PC.
Scope of supply: interface converter, 9-pin Dsub extension cable



EBW 240 incl. software EASYControl net
interface converter for connection of max. 240 EASYBus-modules to the RS232-interface of your PC.
Scope of supply: interface converter, plug-in power adapter, 9-pin Dsub extension cable, software EASYControl net.

Specification:

	EBW 1	EBW 3	EBW 64	EBW 240
Voltage supply:	230 V AC / 50Hz 12/24 V DC on request	not necessary	230 V AC / 50Hz	230 V AC / 50Hz (over power adapter)
Power consumption:	approx. 5 W	max. 0.5 W	approx. 15 W	approx. 30 W
Max. permissible sensor modules *:	9	1	64	240
Permissible cable length **:	200 m	10 m	1000 m	1000 m
Baud rate:	4800 Baud			
Serial connection:	RS232	USB	RS232	RS232
Electrical isolated:	yes	yes	yes	yes
Overload display:	no	no	yes	yes
Short-circuit proof:	yes (limited: 30sec.)	no	yes (passiv)	yes (activ)
Operating temperature:	0 ... 50 °C	-25 ... 50 °C	0 ... 50 °C	0 ... 55 °C
Humidity:	20 ... 80 %RH, non-condensing			
Storage temperature:	-20 ...+70 °C	-25 ...+70 °C	-20 ...+70 °C	-20 ...+60 °C
Dimensions (H x W x D):	112 x 80 x 45 mm	56 x 31 x 24 mm	100 x 75 x 110 mm	200 x 240 x 55 mm (without power adapter)
Bit Recovery	no	no	yes	yes

* depending on type of the used sensor modules

** depending on type of cable and wiring

Interface accessories



USB-Adapter for connection of an interface converter (except EBW 3) to the USB-interface of your PC

GSA 9S-25B connection-adapter: 9-pin Dsub-plug <=> 25-pin Dsub-socket



*Note: the EASYBus-monitoring device **EB2000** should be can used as a converter for max. 9 sensor modules.*

EASYBus - components





Sensor modules

Logger module	(for temperature, humidity, pressure, norm. signals, frequency)	<i>p.r.t. page 80 - 82</i>
Sensor module	(for temperature, humidity, norm. signals, frequency, ...)	<i>p.r.t. page 84 - 87</i>
GIA 20 EB	EASYBus module for norm. signal and temperature, with 2 switching outputs	<i>p.r.t. page 62</i>
GIA 2000	EASYBus module for norm. signal and temperature	<i>p.r.t. page 65</i>
GIR 2002	EASYBus module for norm. signal and temperature, with 2 relay outputs	<i>p.r.t. page 66</i>
EBB 1 IN	EASYBus sensor module with 1 digital input to monitor a electrically insulated contact	
EBB 4 IN	EASYBus sensor module with 4 digital input to monitor a electrically insulated contact	
	Input: EBB 1 IN: 1 digital input for electrically insulated contact EBB 4 IN: 4 digital input for electrically insulated contact	
	Housing: snap-on housing	
	Dimensions: approx. 22.5 x 78 x 105 mm	

Logger accessories

	ESK-1	external starting key, independent from mains supply to start logger of the type EASYLOG 40... and EASYLOG 24... in the starting mode St.Et
	GWH 40K	wall suspension with lock as protection against theft suitable for all EASYLOG (except EASYLOG 40NS W), EBN/K - ..., GIA0420WK and GRA0420WK
	GWH 10	simple wall suspension, made of stainless steel, suitable for all EASYLOG (except EASYLOG 40NS W). mount wall suspension at the monitoring point, the logger may now be easily put in.

Cable

	EBSK 01	special plug with approx. 1 m of cable for connection of one EASYLOG , EBN.. to the EASYBus
	EBSK 03	special plug with approx. 3 m of cable for connection of one EASYLOG , EBN.. to the EASYBus
	EBSK 10	special plug with approx. 10 m of cable for connection of one EASYLOG , EBN.. to the EASYBus <i>(Please note: the EASYLOG will be supplied without connection cable. The GSOFT40K includes a connection cable EBSK01. Please order EBSK01, EBSK03 resp. EBSK10 as required in case of permanent bus connection!)</i>
	VSL 2P	twisted special cable for EASYBus-system, cross section 2 x 0,75 mm ² per m
	AKL 1P	special branch terminal for connection to VSL2P, 2 pieces

Interface converter

EBW 1, EBW 64, EBW 240	EASYBus interface converter, RS232, main supply	<i>p.r.t. page 92</i>
EBW 3	EASYBus interface converter, USB	<i>p.r.t. page 92</i>
EB 2000 MC	EASYBus-display and monitoring device for 9 channels	<i>p.r.t. page 89</i>

Interface accessories

USB-Adapter	for converter connection to an USB interface
GRS 01/9	interface cable for EB2000 MC for connection to 9-pin RS232 interface of a PC
GRS 02/9	interface cable for EBW2 for connection to a MODEM ...
GSA 25S-9B	connection-adapter: 25-pin Dsub-plug <=> 9-pin Dsub-socket
GSA 9S-25B	connection-adapter: 9-pin Dsub-plug <=> 25-pin Dsub-socket

Software

EBS 20M	Windows software for recording and archiving of max. 20 sensor modules	<i>p.r.t. page 91</i>
EASYControl net	Windows software for monitoring, recording, displaying	<i>p.r.t. page 91</i>
GSOFT 40K	Windows software to service the EASYLOG	<i>p.r.t. page 90</i>
ProfiLab-Expert	Windows software	<i>p.r.t. page 58</i>
EASYBUS.dll	Windows-function library for interface communication EASYBus - PC, to integrate in your own programmes	

EASYBus - components

Alarm monitoring

EBUW 232 A independent alarm monitoring module for EASYBus-modules



The EBUW232A monitors independently, it means without additional PC up to 240 EASYBus-modules for their alarm conditions. If an alarm is present, the alarm output of the EBUW 232 A will be set. With the included adapter cable the relay module GNR 232 A can be controlled. Additionally an adequate to the bus connected switching module (EBB .. OUT) can be controlled.

Power supply: 6 - 12 V DC, max. 10 mA (connection over approx. 50 cm adapter cable)
Switching output: NPN open-collector, max. switching capacity: 24 V, 50 mA (connection over adapter cable)

GNG 12 - LE plugin power supply 12 V DC / 300 mA

GNR 232 A Power supply and relay module for EBUW 232 A



Power supply: 230 V, 50/60 Hz
Output voltage: 12 V DC $\pm 5\%$ (regulated) 25 mA
Relay output: volt-free changeover contacts, switching current max. 10 A ohmic load
Connection: screw-type terminal
Dimensions: 96 x 61 x 60 mm (H x B x T)

EB 2000 MC EASYBus-display and monitoring device for 9 channels

p.r.t. page 89

EB 3000 EASYBus-display, regulating and monitoring device for 20 channels

p.r.t. page 88

Switching modules

EBB 2 OUT / BP EASYBus switching module, 2 relay, bus-powered

EBB 2 OUT / 12V EASYBus switching module, 2 relay

EBB 4 OUT / BP EASYBus switching module, 4 relay, bus-powered

EBB 4 OUT / 12V EASYBus switching module, 4 relay



The EBB ... OUT / ... are switching modules for the EASYBus that can be arbitrarily placed on a location in the bus system. The control of the modules' relays is realized by an alarm monitoring module EBUW232A or by PC-software (e.g. EASYControl).

There are 2 different design types of the switching modules:

... / BP: Bus Power - no external auxiliary supply needed

... / 12V: external 12V-supply needed - this allows faster switching and a higher operating reliability due to adjustable preferred relay states in case of a system failure. (*Power supply unit not in scope of supply*)

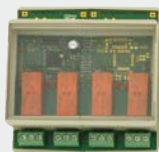

	EBB 2 OUT / BP	EBB 4 OUT / BP	EBB 2 OUT / 12V	EBB 4 OUT / 12V
Power supply:	Powered by the EASYBus		12 V DC $\pm 10\%$ / 150 mA	
Switching outputs:	2 changers	4 changers	2 changers	4 changers
Switching reaction:	< 1 seconds	< 2 seconds	< 0.1 seconds	< 0.1 seconds
Switching power:	max. 250 V AC / 16 A ohmic load			
Connection:	screw type terminal			
Dimensions:	96 x 48 x 60 mm	96 x 94 x 60 mm	96 x 48 x 60 mm	96 x 94 x 60 mm

Remote operation



MODEM 2600 analog hat rail MODEM with alarm input and SMS alarm  for the EASYBus remote data transfer via analog telephone nets.

Scope of delivery: 1x Modem, 1x plug power supply, 1x TAE cable, 1x protocol converter EBUW232, 1x null modem cable, 1x9-pol. DSub connection cable

MODEM 3500 GSM GSM MODEM with alarm input and SMS alarm for the EASYBus remote data transfer via 900MHz mobile nets (D1, D2, etc.).

Scope of delivery: 1x Modem, 1x. protocol converter EBUW 232, 1x null modem cable, 1x 9-pol. DSub connection cable

Accessories: Antenna GSM (Dual-band industrial antenna with bracket)



DFM 232 SET Wireless data connection, 433MHz, consisting of transmitter and receiver for wireless data transmission to EASYBus-modules via 433Mhz radio network.

Bi-directional RS232 interface (DB9), e.g for the connection of EBW 1, large range of up to 1500 m at free air, within buildings similar to DECT telephones.



LAN 3000 Serial-to-Ethernet-Converter

for remote access to EASYBus-modules via LAN or Internet.

Serial RS232 Input (DB-9) e.g. for EBW1, 1* LAN Port RJ-45 10/100Mbps

Supported protocols: TCP, DHCP, HTTP, etc. / Network connection via: Stat. IP, DHCP or PPPoE

Transmitter

	Measurands											Description	Page
	Temperature	Air humidity	Air flow	Pressure	Carbon monoxide / -dioxide	Oxygen	pH / Redox	Conductivity	Rotational speed	Flow	Level		

TRANSMITTER



GTMU ..	✓												Wall- or channel-mounted version	96
GTP .. / GNTP	✓												Transmitter board / snap-on housing	98
GTMU - IF ..	✓												Stainless steel housing	99
T03 BU ..	✓												Analog head transmitter	99
RT420 ..	✓												Head transmitter	100
GITT01 ..	✓											✓	programmable head transmitter	101
MU 500 ..	✓											✓	electr. isolated head transmitter, snap-on	102
ST 500 ..												✓	Universal isolating signal converter, snap-on	102
IR-CT 20	✓												Infrared Transmitter	103
TF1 ..	✓												Temperature Switch	103
GRHU .. MP		✓											Wall- or channel-mounted version	104
GHTU .. MP	✓	✓											Wall- or channel-mounted version	104
GSMU ..			✓										Wall-mounted or Mini version	105
GMUD / GMDP				✓									Wall mounted version / transmitter board	106
A-10 / S-10 .. / S-11 ..				✓									Stainless steel pressure transmitter	107
GT1-CO / GT10-CO2-1R					✓								Wall-mounted version	108
OXY 36 .. MP						✓							Wall-mounted version	109
GPHU .. / GRMU ..							✓						Wall-mounted version	110
GLMU .. MP								✓					Wall-mounted version	111
EFFI / EFFU									✓				Stainless steel housing	112
EFK2 / EFKP / EFKM										✓			Stainless steel housing	112
RRI - 0.. / ..										✓			Flow meter (with rotor)	113
FCM ..										✓			Flow switch with angle plug	113
FHK.. / EPI										✓			Flow meter with NPN-Output	114
VISION 2008 / VTH 25 ..										✓			Flow transmitter with Hall-effect sensor	115
GSS-F25											✓		Level switch	115
GBS ..										✓	✓		Water level / well probe	116
GNS ..										✓			Level switch with micro-switch / reed contact	116
RWI ..										✓			Float switch	118
LC .. / GNS-KIT										✓			Level transmitter	119

GTMU-MP

General

The new generation of our transducers brings more flexibility thanks to state of the art digital microprocessor technology. Due to the many different design types and a measuring range of -50 ... 400 °C nearly all kinds of applications can covered.

- on site temperature display
- output signal freely scaleable
- user-adjustment possible
- possible output signals: 4-20 mA, 0-1 V or 0-10 V

Design types

Design type 1

for direct screw connection
probe with threaded stem "G"

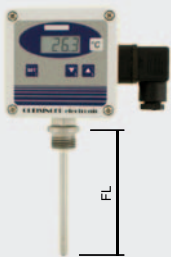

Standard type:

G = 1/2", FL = 100mm, D = 6mm

Design type 2

for high temperatures
threaded stem at a distance of HL
(collar tube) from housing

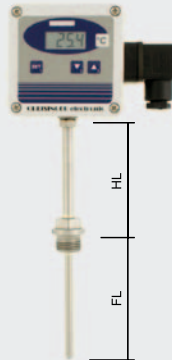

Standard type:

G = 1/2", HL = 100mm,
FL = 100mm, D = 6mm

Design type 3

indoor / outdoor probe
for direct wall mounting



Standard type:

FL = 50mm, D = 3mm

Design type 4

duct probe
centrally mounted sensor tube pointing
downwards
(for clamping ring screw connection p.r.t. page 134)



Standard type:

FL = 100mm, D = 6mm

Specification

Measuring range:	-50.0 ... +400.0°C, free scaleable <i>The probe length FL has to be chosen long enough, that the allowable temperature of the case and the electronics of 70°C is not exceeded !</i>
Accuracy: (at 25°C)	electronic: ±0.4% of meas. value ±0,2°C output signal: ±0.2% f.s.
Probe:	PT1000, 2-wire, DIN class B (standard) <i>optional higher sensor accuracy available (p.r.t. page 121)</i>
Output signal:	standard: 4-20mA (2-wire), freely scaleable option: 0-1V, 0-10V (other output signals upon request)
Connection:	4 - 20 mA (2-wire) for option AV01, AV10: 0 - 1 (10) Volt (3- or 4-wire)
Auxiliary energy:	12 ... 30 VDC or 18 ... 30VDC (for output: 0-...V)
Reverse voltage protection:	50V, permanently
Perm. impedance (at 4-20mA):	RA [Ω] = (Uv [V] - 12V) / 0.02 A
Permissible load (at 0-1(10)V):	RL [Ω] > 3000Ω
Display:	approx. 10 mm high, 4-digit LCD-display
Working temperature:	-25 to 70°C (electronic)
Storage temperature:	-25 to 70°C
Relative humidity (electronic):	0 to 95 %RH (non-condensing) <i>If there is a risk of condensation due to temperature changes, please use our encapsulated or lacquered types (option).</i>
Housing:	ABS (IP65)
Probe tube:	stainless steel
Probe length:	for standard length please refer to design type, any other tube length possible <i>The probe length FL has to be chosen long enough, that the allowable temperature of the case and the electronics of 70°C is not exceeded !</i>
thread "G":	G1/2" (standard), optional: G1/4", G3/8", G3/4", M10, M12, M14, M16
Probe diameter "D":	3, 4, 5, 6 or 8 mm
Electric connection:	elbow-type plug acc. to EN 175301-803/A (IP65)
Mounting:	4 housing holes for wall mounting or by means of plastic tube clamps for duct mounting
Functions:	min-/max-value memory, offset and slope digital adjustable, output signal freely scaleable (without tools)

Prices - temperature transducer

- GTMU - MP design type 1
- GTMU - MP design type 2
- GTMU - MP design type 3
- GTMU - MP design type 4

Options / upcharges

- AV01: output signal 0-1V upcharge:
- AV10: output signal 0-10V upcharge:
- LACK: encapsulated PC board upcharge:
(for outdoor application, i.e. applications where condensation is possible)
- FL=...: longer tube, each started further 100mm upcharge:
- HL=...: longer collar tube, each started further 100mm upcharge:
- D=...: other probe diameter
- G=...: other thread

Accessories

Clamping ring screw connection **please refer to page 134**

Ordering information

If no additional data is added to the design type, the probe will be manufactured with standard dimensions. If different dimensions are needed, they have to be specified.

Ordering examples:

GTMU-MP, type 1
GTMU-MP, type 3, FL = 100 mm, D = 4 mm

Temperature transducer GTMU



cpl. with Pt100 or NiCr-Ni (type K) sensor

General

You can choose between 5 design types of the GTMU and 2 sensor types to get an optimised solution for Your needs.

The types 1 - 4 are supplied cpl. with sensor, measuring transducer etc., calibrated and thus ready for use. Type 5 does not include sensor which is either already existing at your works or will have to be ordered separately acc. to your specifications (p.r.t. pages 126-127, 130-131)

design type 1	design type 2	design type 3	design type 4	design type 5
for direct screw connection	for high temperatures	indoor / outdoor probe	duct probe	for external probes
probe with threaded stem "G"	threaded stem at a distance of HL (collar tube) from housing	for direct wall mounting	centrally mounted sensor tube pointing downwards. <i>(for clamping ring screw connection p.r.t. page 134)</i>	measuring transducer for Pt 100 or NiCr-Ni sensors already existing on site or for applications where sensor and housing need to be spaced. <i>(e.g. due to extremely high ambient temperatures or to design reasons).</i>
Standard: G = 1/2", FL = 100mm, D = 6mm	Standard: G = 1/2", HL = 50mm FL = 100mm, D = 6mm	Standard: FL = 50mm, D = 3mm	Standard: FL = 100mm, D = 6mm	

Specification

Practical sensor elements:

- resistance thermometer: Pt100 class B (higher sensor precision p.r.t. page 121)
- thermocouple: NiCr-Ni class 1

Max. measuring ranges:

- Pt100: -200 ... +800°C
- NiCr-Ni: -200 ... +1372°C

Standard measurings ranges:

- Pt100: 0...100°C, 0...200°C, -50...+50°C, -50...+150°C
- NiCr-Ni: 0...100°C, -50...+150°C, -200...+300°C, 0...600°C, 0...1200°C
- Optional: any other measuring range against upcharge

Accuracy electronics: ±0.2% FS (Pt100) or ±0.2% ±0.5°C (NiCr-Ni)

Higher precision e.g. via optionally different transducer (GITT01, RT420)

Output signal:

- Standard: 4 - 20 mA (2-wire)
- Optional: 0-1V, 0-2V, 0-5V, 0-10V (3- or 4-wire) *(not available for GITT01, RT420)*

Auxiliary energy: Uv = 12 ... 30 V DC (at 0-10V: Uv = 18 ... 30 V DC)

(for special types GTMU/GITT and GTMU/RT420: 8 ... 30 V)

Reverse voltage protection: 50 V permanently

Allowable burden (for 4-20mA): RA [Ω] = (Uv [V] - 12V) / 0.02 A

(for special types GITT and RT420 refer to this pages)

Allowable load (for 0-__ Volt): RL > 3000Ω

Ambient temperature electronics: 0 ... +70°C (-40...+85°C at .../RT420 and .../GITT)

Temperature coefficient: Pt100: 0.01 % / °C

NiCr-Ni: 0.05 % / °C

Storage temperature: -20 ... +70°C

Housing: ABS (IP65)

Probe tube: stainless steel

Probe length: optional: for standard length please refer to design type, any other tube length possible

Thread "G": optional: 1/2" (Standard), G1/4", G3/8", M5, M6, M8, M10, M12

Probe diameter "D": optional: 3, 4, 5, 6 or 8 mm

Sensor installation: Pt100: sensors will be electrically insulated at our works.

NiCr-Ni: sensors are not electrically insulated as a standard (connection between sensor and outer sheathing). Optional electrically insulated design-type available.

Mounting: with holes for wall mounting

Mounting distance: 70 x 50 mm (W x H)

Fixing screws: max. shaft-Ø 4 mm

Electric connection: elbow plug acc. to EN 175301-803/A (IP65)

Sensor connection: (for type 5) Pt 100: 2- or 3-wire connection possible

NiCr-Ni: 2-wire only

PG 7 screwed conduit entry for sensor cable connection by screw-type terminal on PC board

Ordering information

At least necessary ordering information: design type, sensor and meas. range

If no additional data is added to the design type, the probe will be manufactured with standard dimensions.

Ordering examples:

GTMU, type 1, Pt100 DIN KL.B., 0...100°C

GTMU, type 3, NiCr-Ni, 0...1200°C, FL=100mm, D=4mm, POT

Prices - temperature transducer

GTMU design type 1

GTMU design type 2

GTMU design type 3

GTMU design type 4

GTMU design type 5

Upcharge - transducer options

GTMU / GITT electrically isolated transducer upcharge:
(available sensors: Pt100, Pt1000, NiCr-Ni, only output 4-20mA possible)

GTMU / RT420 transducer for outdoor usage
(available sensors: Pt100, only output 4-20mA possible)

Options / upcharges

- AV...: other output signal upcharge:
(please state desired output voltage - not available with GITT and RT420)

- MB=...: any other measuring range upcharge:
(please state desired measuring range)

No upcharge for option -AV., -MB if more than 10 pcs per type are ordered.

- LACK: encapsulated PC board upcharge:
(for outdoor application, i.e. applications where condensation is possible)

- POT: electrically insulated NiCr-Ni-probe upcharge:

- FL=...: longer tube, each started further 100mm upcharge:

- HL=...: longer collar tube, each started further 100mm upcharge:

- D=...: other probe diameter

- G=...: other thread upon request

- VO: on-site display upcharge:
(for output signal 4-20mA, auxiliary energy Uv = 17 ... 30 V DC)

Prices - sensor housing without transducer

We also offer the sensors without the integrated transducer. The sensor connection then are directly connected to the elbow plug.

GTMU-OMU design type 1

GTMU-OMU design type 2

GTMU-OMU design type 3 or design type 4
(available sensors: Pt100 (4-wire), Pt1000 (4-wire), NiCr-Ni)

GTU-2R-OMU designer housing for ambient
(available sensors: Pt100 (4-wire), Pt1000 (4-wire))

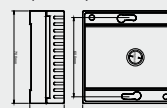

Note: the housing also maybe mounted directly to a concealed distribution box.

Temperature-measuring PCB for Pt100 or in snap-on housing

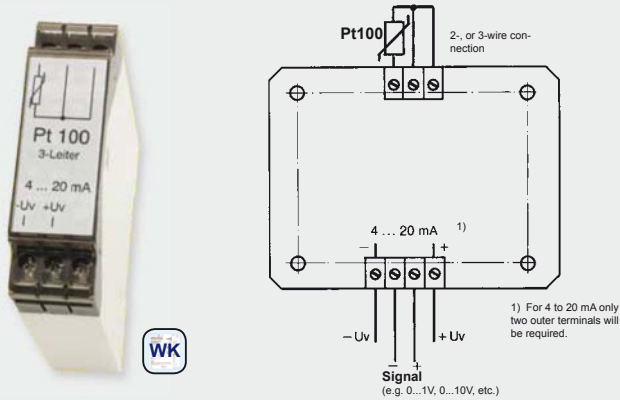

GTP PCB

GTP -SG snap-on housing

Design-type: PC board completely ready for operation (sensor not included) with any measuring range and any output. 3-pin connection terminal for Pt 100 in 2 or 3-wire technology. Connection terminal for output in 2-, 3-, or 4-wire technology - depending on type desired.

Specification :

Sensor element: for Pt 100 acc. to DIN IEC 751.
Suitable sensors available (prepared or unprepared) from stock - please refer to pages 130-131

Sensor connection: 2- or 3-wire connection.
Automatic line resistance compensation for 3-wire connection.

Measuring ranges: from -200 to +800°C
Standard ranges: GTP 0100: 0 ... 100°C
GTP 0200: 0 ... 200°C
GTP 5050: -50 ... +50°C
GTP 5015: -50 ... +150°C

OPTION: any measuring range available against upcharge

Output signal: 4 - 20 mA (2-wire)
optionally 0-1V, 0-2V, 0-5V, 0-10V (3- or 4-wire)

Auxiliary energy: $V_s = 12 \dots 30 \text{ V DC}$ (at 0-10V: $V_s = 18 \dots 30 \text{ V DC}$)

Reverse voltage protection: 50 V permanent

Permissible impedance (at 4-20mA): $R_A [\Omega] = (U_v [V] - 12V) / 0.02A$

Permissible load (at 0-__ Volt): $R_L [\Omega] > 3000\Omega$

Operating temperature electronics: 0 ... +70 °C

Temperature coefficient: 0.01% / °C

Storage temperature: -20 ... +70 °C

Housing: ABS (IP65)

Relative atmospheric humidity: 0 ... 80% r.h., non-condensing Option: encapsulated PC board

PC board dimensions: approx. 56,5 x 73 x 20 mm (H x W x D)

Option snap-on housing: for top-hat rail (panel mounting),
Width of housing (pitch) 22.5 mm

Mounting: 4 holes, 3.5 mm Ø each
Mounting distance: 43,5 x 58 mm (W x H)

Miscellaneous: potentiometer for zero point and scale

Electric connection: screw-type terminals with wire protection and drill holes for testing pin, wire Ø max. 1.5 mm².
option: screw-type/plug-in terminal

Order codes (examples):

GTP0100 / LACK, SSK: PCB, 4-20mA = 0 ... 100°C, encapsulated PC board, screw-type/plug-in terminals

GTP -SG / AV010, MB: -50...+200°C: snap-on housing, 0-10V = -50...+200°C

options - upcharges:

-AV010: option: output signal 0-10V

-AV...: option: other output signal
(please state desired voltage)

-MB: option: arbitrary measuring range
(please state desired measuring range)
No upcharge for option -AV..., -MB if more than 10 pcs. are ordered

-LACK: option: encapsulated PC board
(for outdoor application, i.e. applications where condensation is possible)

-SSK: option: screw-type/plug-in terminals
(not possible for type snap-on housing)

PC board for measuring transducer mounted in water-proof surface-type housing (IP65) p.r.t. type GTMU design-type 5 (page 97)

Temperature-measuring PCB for NiCr-Ni or in snap-on housing

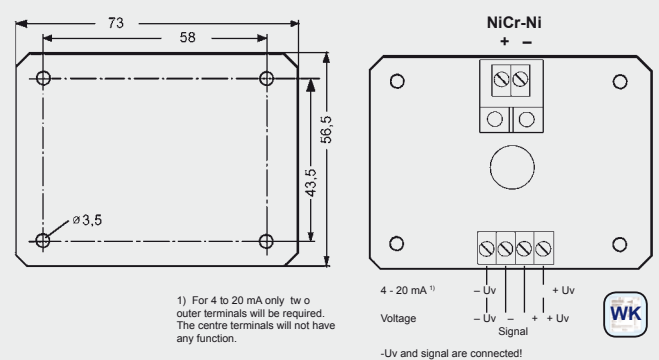

GNTP PCB

GNTP -SG snap-on housing

Design-type: PC board completely ready for operation (sensor not included) with any measuring range and any output. 2-pin connection terminal for NiCr-Ni-sensor or compensation line. Optionally available: PC board with DIN type flat-pin jack free from thermo voltage for direct plug-in of temperature sensors with DIN type flat-pin plug. Connection terminals for output 2- to 4-pin (depending on output in 2-, 3- or 4-wire technology).

Specification :

Sensor element: for NiCr-Ni (type K) acc. to DIN IEC 584
suitable sensor can be supplied custom-designed according to your specifications or in standard design from stock (p.r.t. pages 123-127)

Meas. range: from -200 to +1200°C
Standard ranges: GNTP 0100: 0 ... 100°C
GNTP 0600: 0 ... 600°C
GNTP 01200: 0 ... 1200°C
GNTP 5015: -50 ... +150°C
GNTP 2030: -200 ... +300°C

OPTION: any measuring range available against upcharge

Output signal: 4 - 20 mA (2-wire)
optionally 0-1V, 0-2V, 0-5V, 0-10V (3- or 4-wire)

Auxiliary energy: $V_s = 12 \dots 30 \text{ V DC}$ (at 0-5/10V: $V_s = 18 \dots 30 \text{ V DC}$)

Reverse voltage protection: 50 V permanent

Permissible impedance (at 4-20mA): $R_A [\Omega] = (U_v [V] - 12V) / 0.02A$

Permissible load (at 0-__ Volt): $R_L [\Omega] > 3000\Omega$

Operating temperature electronics: 0 ... +70 °C

Accuracy electronics: ±0.2% FS ±0.5°C

Temperature coefficient: 0.05% / °C

Storage temperature: -20 ... +70 °C

Relative atmospheric humidity: 0 ... 80%RH, non-condensing
Option: encapsulated PC board

PC board dimensions: approx. 56,5 x 73 x 20 mm (H x W x D)

Option snap-on housing: for top-hat rail (panel mounting),
Width of housing (pitch) 22.5 mm

Mounting: 4 holes, 3.5 mm Ø each
Mounting distance: 43,5 x 58 mm (W x H)

Miscellaneous: potentiometer for zero point and scale

Electric connection: screw-type terminals with wire protection and drill holes for testing pin, wire Ø max. 1.5 mm².
option: screw-type/plug-in terminal

Order codes (examples):

GNTP / MB: 0...300°C, LACK, SSK: PCB, 4-20mA = 0 ... 300°C,
encapsulated PCB board, screw-type/plug-in terminals

GNTP5015-SG / AV: 0-1V: snap-on housing, 0-1V = -50 ... +150°C

options - upcharges:

-AV010: option: output signal 0-10V

-AV...: option: other output signal
(please state desired voltage)

-MB: option: arbitrary measuring range
(please state desired measuring range)
No upcharge for option -AV..., -MB if more than 10 pcs. are ordered

-LACK: option: encapsulated PC board
(for outdoor application, i.e. applications where condensation is possible)

-SSK: option: screw-type/plug-in terminals
(not possible for type snap-on housing)

-TSK: option: DIN type flat-pin jack free from thermo voltage
(not possible for type snap-on housing)

PC board for measuring transducer mounted in water-proof surface-type housing (IP65) p.r.t. type GTMU design-type 5 (page 97)

Temperature transmitter with digital adjustment

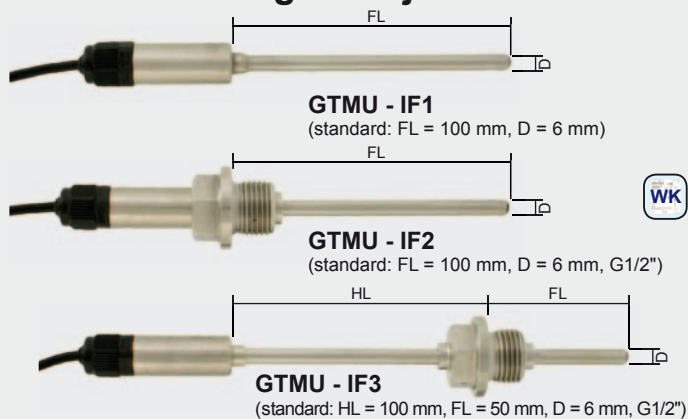

GTMU - IF1

GTMU - IF2

GTMU - IF3

Specification:

Meas. range: The probe length FL has to be chosen long enough, that the allowable temperature range of the electronics situated in the tube sleeve is not exceeded.

GTMU - IF1 (standard): -30,0 ... +100,0 °C

GTMU - IF2 (standard): -30,0 ... +100,0 °C

GTMU - IF3 (standard): -70,0 ... +400,0 °C

other measuring ranges (max. -200 ... +500 °C) **upon request**

Meas probe: internal Pt1000-sensor

Accuracy: (at nominal temperature = 25 °C)

Electronic: ±0,2 % of meas. value ±0,2 °C

Meßfühler: standard: DIN class B
optionally higher sensor accuracy available

Output signal: 4 ... 20 mA (2-wire)

Auxiliary energy: $U_v = 10 \dots 30$ V DC

Permissible burden: $R_A \leq (U_v - 10 \text{ V}) / 0,022 \text{ A}$ [R_A in Ohm, U_v in V]

Scaling: the transducer can be scaled freely within the measuring ranges via GTMU-IF programming tool.

Operating temperature of electronic (in tube sleeve): -25 to 60 °C

Housing: stainless steel housing

Dimensions: depending on sensor construction

tube sleeve: Ø15 x 35 mm (without screwing)

tube length FL: 100 or 50 mm *or on customer requirement*

tube diameter D: Ø 6 mm *or on customer requirement*
(available Ø: 4, 5, 6 and 8 mm)

collar tube length HL: 100 mm *or on customer requirement*

thread: G1/2" *or on customer requirement*
(available threads M8x1, M10x1, M14x1.5, G1/8", G1/4", G3/8", G1/2", G3/4")

Electric connection: approx. 1 m long 4-pin cable
(2 x current loop, 2 x interface)

Options (upcharges):

- FL=...: longer tube, *each started further 100 mm*
- HL=...: longer collar tube, *each started further 100 mm*
- D=...: other tube diameter
- G=...: other thread upon request
- MB=...: other measuring ranges, set by factory
- M12: electric connection: M12 plug



Accessories:

GTMU-IF - Programming tool

USB-interface adaptor for GTMU-IF, incl. configuration software

Analog Pt100-transmitter with digital adjustment



T03 BU / WE *1 (transmitter 0-10V, set by our works)

*1 = please specify design-type desired on your order.
e.g. T03BU, Pt100 3-wire, 0...10 V = 0 - 250 °C

General: These transmitter are designed for industrial applications and are used to measure the temperature through Pt100 resistance thermometers in 2-/3-wire circuits connections. The 0...10 V output signal is linear with temperature. The advantages of a continuous analog signal path and those of digital adjustment have been combined in the realization of this transmitter series.

Specification:

Measurement input: Pt100 (DIN EN60751)

Range limits: -200 ... +850 °C

Meas. span: 40 to 1050 K

Zero shift: at span < 75K: -40, -20, 0, 20 or 40 °C
at span = 75K: ± 50 °C
at span > 75K: ± (span * 0.2 + 35 °C)

Sensor connection: 2- or 3-wire connection

Meas. current: < 0,5 mA

Max. perm. line resistance (3-wire): 11 Ohm per conductor

Sampling time: continuous because of analog signal path

Output signal: 0...10 Volt, 3-wire technology

Setting time on a temperature change: ≤ 10 ms

Transfer characteristic: linear with temperature

Transfer accuracy: ≤ ±0.2 % FS

Calibration accuracy: ≤ ±0.2 °C or ±0.2 % FS

Supply voltage: $U_b = 15 \dots 30$ V DC

Supply voltage error: ±0.01 % FS / V

Permissible load R_L : $R_L \geq 10$ kOhm

Load error: ≤ ±0.1% FS

Operating temp.: -40 ... +85 °C

Relative humidity: 0... 95 %RH (non condensing)

Storage temperature: -40 ... +100 °C

Electromagnetic compatibility (EMC):
conforming to **CE** acc. to DIN EN 61326

Electric connection: via terminals,
cross section of connection terminals max. 1,75 mm²

Housing: PC-housing, suitable for installation in connection head acc. to DIN 43729 form B.

Operating position: unrestricted

Dimensions: Ø 44 mm x 21 mm

IP-rating: housing: IP54, connection terminals: IP00

Weight: approx. 45 g

Accessories:

Rail adapter

(rail adapter for snap-on to top-hat rail)

Programming tool for T03BU

The programming tool consists of: configurations software, connection cable RS 232-C (approx. 1m long, 9-pin Dsub-plug)

Temperature-measuring transducer 4-20mA, Pt100, 2- / 3- or 4-wire

for head and rail case mounting

Panel-mounted-resistance thermometer with measuring transducer RT420



RT420 - advantages:

- low-price and robust (complete sealed - no pots, therefore vibration resistant and long time stable)
- freely programmable - extreme wide measuring range of -200 to 850 °C (measuring span already from ≥ 25 °C)
- selectable probe connection as 2- / 3- or 4-wire
- high accuracy (0.1%)
- large ambient temperature range (-40 ... +85°C)
- error message in case of sensor damage or sensor short-circuit
- functional warranty 5 years

RT420 / WE *1

head transmitter, set by our works

Rail adapter

upcharge:

for snap-on the RT420 to top-hat rail

RT420 - SG / WE *1

set by our works and mounted in snap-on rail housing

*1 = Ordering data required:

1. required probe connection (2- / 3- or 4-wire)
2. measuring range from / to (max. range: -200 ... +850 °C)

Order example: RT420 / WE, 4-wire, 0...50 °C
RT420-SG / WE, 3-wire, -50...+150 °C



RT420 with rail adapter

GTF103 / RT420 (p.r.t. page 131)

Panel-mounted resistance thermometer

Pt100 cpl. with measuring transducer RT420 - transducer and Pt100 can be taken out in form of an insert. (Price valid for standard length 100 mm and temperature range as to customers specification between -50 ... +400 °C)

Special designs upon request - please contact us!

GTF103/RT420



RT420-insert with Pt100-sensor of a GTF103/RT420

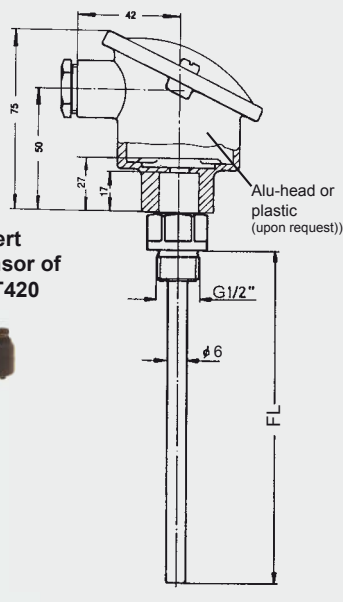

Specification:

- Measuring range: -200 ... +850 °C, universally programmable
 Measuring span: 25 to 1050 K
 Zero shift: -200 ... +825 °C
 Resolution: 14 bit
 Sensor connection: 2-, 3- or 4-wire connection
 Meas. current: < 0,3 mA
 Perm. resistance of connection cable: max. 20 Ohm / wire
 Compensation for cable error: $\pm 0,02$ K / Ohm (at 3-wire)
 Sensor monitoring: monitoring for sensor damage and short-circuit
 Meas. cycle: < 700 ms
 Linearisation: linear to temperature acc. to IEC/DIN/EN 60 751-2
 Accuracy: $\pm 0,25$ °C or $\pm 0,1\%$ of meas. span
 Temperature effect: $< \pm 0,01\%$ / 1K
 Analog output: 4...20 mA, 2-wire technology
 Accuracy output: <0.1% of signal span
 Auxiliary energy: V_s 8 ... 35 V DC (max. ripple factor: 3V_{ss} @ 50/60Hz)
 Perm. burden R_A : $R_A \leq (V_s - 8V) / 0,023 A$ [R_A in Ohm, V_s in V]
 Effect of aux. energy: $\pm 0,01\%$ / V
 Power-on time: 10 s
 Damping: adjustable from 0 to 30 s
 Output limits: programmable, 3,5 mA, 23 mA
 Signal for sensor damage: programmable, 3,5mA or 23mA
 Operating temperature: -40 ... +85 °C
 Relative humidity: 0... 98 %RH, (non condensing)
 Storage temperature: -55 ... +90 °C
 Electromagnetic compatibility (EMC): conforming to CE acc. to DIN EN 61326
 Housing: housing suitable for head mounting
 Dimensions: $\varnothing 44$ mm x 19 mm
 IP rating: Housing: IP40, connection terminals: IP10
 Electric connection: via screw-type terminals
 Weight: approx. 35 g
 Design type ...-SG (snap-on rail housing)
 Dimensions: approx. 22.5 x 78 x 105 mm
 Electric connection: via screw-type terminals
 Weight: approx. 110 g



Accessories:

Programming tool for RT420

The configuration set contains: configuration software, connection cable RS 232-C, battery plug, connection cable and operating manual

For easy storage management at customers site (customer programmability - all ranges and wiring options can be fully utilised)

Programmable, electrically isolated, 4-20 mA universal transmitter GITT01

GITT01 *1

GITT01 - Ex *1

(Ex-protection: ATEX II 1G Ex ia IIC T6/T5 /T4)

*1=Transmitter can either be programmed by customer or by our works - please specify type upon order.
(e.g. GITT01, NiCr-Ni (type K), 4...20mA = 0 - 300°C)

Accessories:

Rail adapter

(rail adapter for snap-on to top-hat rail)

Programming tool for GITT01

The programming tool consists of: configurations software, connection cable RS 232-C (approx. 1m long, 9-pin Dsub-plug)

- universally programmable for

- resistance thermometers
- thermocouples
- resistance sensor
- voltage sensor



- electrically isolated
- output linear to temperatur
- high accuracy for the entire ambient temperature range (-40...85°C)
- available with Ⓢ - protection
- error messages in case of sensor damage or short-circuit, settings acc. to NAMUR NE43
- configuration can be carried out during measuring

Specification:

Input signal: can be universally programmed to

- Resistance thermometer:	max. meas. range	min. meas. span
Pt100 acc. to IEC 751	-200 ... +850 °C	10 K
Pt500 acc. to IEC 751	-200 ... +250 °C	10 K
Pt1000 acc. to IEC 751	-200 ... +250 °C	10 K
Ni100 acc. to DIN 43760	-60 ... +250 °C	10 K
Ni500 acc. to DIN 43760	-60 ... +150 °C	10 K
Ni1000 acc. to DIN 43760	-60 ... +150 °C	10 K

- Thermocouples:

Type B, PtRh30-PtRh6	0 ... +1820 °C	500 K
Type C, W5Re-W26Re (ASTME 988)	0 ... +2320 °C	500 K
Type D, W3Re-W25Re (ASTME 988)	0 ... +2495 °C	500 K
Type E, NiCr-CuNi	-270 ... +1000 °C	50 K
Type J, Fe-CuNi (acc. to IEC 584)	-210 ... +1200 °C	50 K
Type K, NiCr-Ni	-270 ... +1372 °C	50 K
Type L, Fe-CuNi (acc. to DIN 43710)	-200 ... + 900 °C	50 K
Type N, NiCrSi-NiSi	-270 ... +1300 °C	50 K
Type R, Pt13Rh-Pt	-50 ... +1768 °C	500 K
Type S, Pt10Rh-Pt	-50 ... +1768 °C	500 K
Type T, Cu-CuNi (acc. to IEC 584)	-270 ... + 400 °C	50 K
Type U, Cu-CuNi (acc. to DIN 43710)	-200 ... + 600 °C	50 K
MoRe5-MoRe41	0 ... +2000 °C	500 K

- Resistance-type sensor:

	max. meas. range	min. meas. span
Resistance	10 ... 400 Ohm	10 Ohm
Resistance	10 ... 2000 Ohm	10 Ohm

- Voltage sensor:

	max. meas. range	min. meas. span
Voltage	-10 ... 100 mV	5 mV

Resistance thermometer:

Sensor connection: 2-, 3- or 4-wire connection

Meas. current: ≤ 0,6 mA

Max. perm. line resistance: 11 Ohm / line

Accuracy: Pt100, Ni100: ±0.2°C or ±0.08% of meas. span
Pt500, Ni500: ±0.4°C or ±0.16% of meas. span
Pt1000, Ni1000: ±0.2°C or ±0.08% of meas. span

Temperature effect: Td = ± (15ppm/K * max. meas. range + 50ppm/K * meas. span)

Thermocouples:

Sensor connection: 2-wire connection

Sensor current: < 350 nA

Accuracy (typ.): ±0.5K (types: K, J, E, L, U), ±1.0K (types: N, C, D), ±2.0K (types: S, B, R, MoRe5-MoRe41)

CJC: Pt100 internal or external (0...80°C)

CJC accuracy: ±1°C

Temperature effect: Td = ± (50ppm/K * max. meas. range + 50ppm/K * meas. span)

Output signal: 4...20 mA or 20...4 mA, 2-wire technology

Linearisation: temperature linear, resistance linear or voltage linear

Auxiliary energy: V_s 8 ... 30 V DC (max.ripple factor: 5V_{ss} for V_s>13V)

Electr. isolation (E/O): U_{eff} = 2 KV AC

Perm. load R_A: R_A ≤ (V_s - 8V) / 0,022A [R_A in Ohm, V_s in V]

Supply effects: ≤ ±0.01% / V deviation from 24V

Load effect: ≤ ±0.02% / 100 Ohm

Digital filter: 0 to 60 s, configurable

Switch-on delay: approx. 4 s

Response time: 1 s

Output limits: 3.8 ... 20.5 mA

Signal in case of sensor damage: 3.6 mA or ≥21.0 mA, configurable

EMC: Interference immunity and emission acc. to EN 61326-1 and NAMUR NE21

Operating temperature: -40 ... +85 °C

Climate class: acc. to EN 60654-1, cl. C; condensation permissible

Vibration strength: 4 g / 2...150 Hz acc. to IEC 60 068-2-6

Electric connection: via terminals, cross section of connection terminals max. 1.75 mm²

Housing: PC-housing, suitable for installation in connection head acc. to DIN 43729 form B.

Dimensions: Ø 44 mm x 21 mm

IP-rating housing: IP54, connection terminals: IP00

Weight: approx. 40 g

Ex-approved: ATEX II 1G Ex ia IIC T6/T5 /T4

Power supply set: U_i ≤ 30 V DC, I_i ≤ 100 mA, P_i ≤ 750 mW
C_i, L_i = negligibly small

Meas. circuit: U_o ≤ 8.2 V DC, I_o ≤ 4.6 mA, P_o ≤ 9.35 mW

Max. connection values: L_o = 4.5 mH (ia IIC), 8.5 mA (ia IIB)
C_o = 974 nF (ia IIC), 1900 nF (ia IIB)

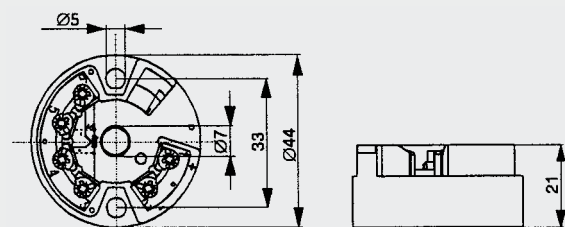

Temperature transmitter (electrically isolated)



MU 500-51-... (Pt100)
MU 500-53-... (Pt1000)
MU 500-Ex-51-... (Pt100)
MU 500-Ex-53-... (Pt1000)

Properties

- **Electrically isolated: between input / output / supply voltage**
- 2 power-supply-designs with wide range of allowed supply voltage: 10 ... 30 V DC / 10 ... 42 V AC or 85 ... 265 V AC / 110 ... 125 V DC
- 22.5 mm standard case for rail mounting TS35
- Several measuring ranges, selectable via rotary switch at front panel (13 for Pt100, 16 for Pt1000)
- Offset and span adjustable

For Ex-designs:

- Input intrinsically safe ATEX II (1) G [Ex ia] IIC, II (1) D [Ex iaD]
- Burden: max. 1000 Ω



Specification

Measuring ranges: selectable via rotary switch
 Pt100: -50 ... 0, -50 ... 50, -30 ... 20, -30 ... 70, -20 ... 30, -20 ... 80, 0 ... 50, 0 ... 100, 0 ... 150, 0 ... 200, 0 ... 300, 0 ... 450, 0 ... 600 °C
 Pt1000: -50 ... 0, -50 ... 50, -30 ... -20, -30 ... -10, -20 ... -10, -20 ... 0, -10 ... 0, -10 ... 10, 0 ... 10, 0 ... 20, 0 ... 30, 0 ... 40, 0 ... 50, 0 ... 100, 0 ... 150, 0 ... 200 °C

Offset adjust: offset: approx. $\pm 8 \Omega$ (± 20 °C for Pt100, ± 2 °C for Pt1000)
 span: approx. ± 20 %

Sensor connection: 2- or 3-wire connection

Sensor current: approx. 1 mA (Pt100), approx. 0.25 mA (Pt1000)

Output signal: 0 - 20 mA, 4 - 20 mA, 0 - 10 V or 2 - 10 V
(selectable via DIP switch)

max. load: burden ≤ 1 k Ω (at mA), load: max. 15 mA (at V)

Basic accuracy: ≤ 0.2 % of measuring range
Temperature coefficient: ≤ 0.01 %/K
Output accuracy: ≤ 0.1 % of measuring range

Power supply: ... - 0 - 00 85 ... 265 V AC / 110 ... 125 V DC
 ... - 5 - 00 10 ... 42 V DC / 10 ... 30 V AC

Power consumption: max. 2.2 W / 3.3 VA

Isolation voltage: 500 V AC, according to VDE 0110 Gr. 2 between input/output/supply voltage

Test voltage: 4 kV DC between input/output/supply voltage

Working temperature: -10 .. 60 °C

Electrical connection: screw-terminals with pressure plates, max. 2.5 mm²

Dimensions: 22.5 x 75 x 110 mm (W x D x H)

Protection: IP 30 (case), IP 20 (terminals)

Ex-certification: TÜV 03 ATEX 2283, II (1) G [Ex ia] IIC, II (1) D [Ex iaD]

Connection data:
 MU 500-ex-ia-51-...: $U_0 = 1.3$ V, $I_0 < 3$ mA, $P_0 < 3$ mW, $C_0 = 29$ μ F, $L_0 = 100$ mA, $C_i = 5$ nF, $L_i = 0$ mH
 MU 500-ex-ia-53-...: $U_0 = 4.9$ V, $I_0 < 3$ mA, $P_0 < 3$ mW, $C_0 = 2.2$ μ F, $L_0 = 100$ mA, $C_i = 5$ nF, $L_i = 0$ mH

Ordering example

MU 500-53-5-00: input = Pt1000, power supply: 10 ... 42 V DC / 10 ... 30 V AC

Isolating signal converter



ST 500-Ex-10-0-00 (230 V AC)
ST 500-Ex-10-5-00 (10..30 V DC/AC)

Properties

Isolating signal converter for application in zone 0 or zone 20 (constant explosion risk) with integrated transmitter supply. It allows the direct connection of active 2-wire sensors (4 ... 20 mA) and 3-wire sensors in the Ex-area.

- Input intrinsically safe ATEX II (1) G [Ex ia] IIC, II (1) D [Ex iaD]
- 2 power-supply-designs with wide range of allowed supply voltage: 10 ... 30 V DC / AC oder 85 ... 253 V AC
- Electrically isolated: between input / output / supply voltage
- 22.5 mm standard case for rail mounting TS35
- Universal inputs/outputs for (0)4 ... 20 mA and 0(2) ... 10 V

Specification

Measuring ranges: selectable
Current input: 0 ... 20 mA or 4 ... 20 mA
 ($R_i = 25 \Omega$, max. 100 mA overload)
Voltage input: 0 ... 10 V or 2 ... 10 V
 ($R_i = \sim 40$ k Ω , max. 100 V overload)

Span: approx. ± 20 %, adjustable

Transmitter supply: approx. 20 V DC, $R_i =$ approx. 300 Ω

Output signal: 0 - 20 mA, 4 - 20 mA, 0 - 10 V or 2 - 10 V
(selectable via DIP switch)

max. load: burden ≤ 1 k Ω (at mA), load: max. 15 mA (at V)

Basic accuracy: ≤ 0.3 % of measuring range
Temperature coefficient: ≤ 0.01 %/K
Repeat accuracy: ≤ 0.1 % of measuring range
Rise time: $T_{90} < 100$ ms

Power supply: ... - 0 - 00 85 ... 253 V AC
 ... - 5 - 00 10 ... 30 V DC / AC

Power consumption: max. 3.5 VA

Isolation voltage: 500 V AC, according to VDE 0110 Gr. 2 between input/output/supply voltage

Test voltage: 4 kV DC between input/output/supply voltage

Working temperature: -10 .. 55 °C

Electrical connection: screw-terminals with pressure plates, max. 2.5 mm²

Dimensions: 22.5 x 75 x 110 mm (W x D x H)

Protection: IP 30 (case), IP 20 (terminals)

Ex-certification: TÜV 97 ATEX 1150, II (1) G [Ex ia] IIC, II (1) D [Ex iaD]

Connection data:
 $U_0 = 25.2$ V, $I_0 = 95$ mA, $P_0 = 600$ mW,
 C_0 / L_0 (ia/IIC) = 47 nF / 2 mH or 107 nF / 0.2 mH,
 C_0 / L_0 (ia/IIB) = 370 nF / 15 mH or 430 nF / 1 mH,
 $C_i, L_i =$ negligible

The intrinsically safe circuit is electrically isolated from the non-intrinsically safe circuits up to a sum of the peak values of the nominal voltage of 375V.

Infrared - measuring transducer IR-CT 20

non-contact temperature measuring from -50 to 975°C



- one of the smallest infrared sensor heads with 20:1 optical resolution
- rugged and applicable without cooling up to 180°C ambient
- adjustable emission factor
- freely scaleable analogue output 0(4)-20mA, 0-10V, thermocouple type J or K
- illuminated liquid crystal display
- large range of supply voltage

Precision infrared transducer

IR-CT 20 -50 ... +975°C, optic 20:1

Scope of supply: electronics-box with LCD, stainless steel sensor head (M12) incl. screw nut, 1m high temperature sensor head cable, manual

Specification

Measuring range:	-50 ... +975°C freely scaleable via programming keys	IP rating:	IP65 (NEMA-4)
Spectral sensitivity:	8 - 14 µm	Ambient temperature:	
Optic resolution:	20:1 (precision glass optics)	Measuring head:	-20 ... +180°C
System accuracy:	± 1% or ±1°C (higher value applicable)	Electronic box:	0 ... +65°C
Repeat accuracy:	±0,5% or ±0,5°C (higher value applicable)	Storage temperature:	
Nominal temperature:	23 ± 5°C	Measuring head:	-40 ... +180°C
Temperature coefficient:	0,05% or 0,05°C/K (higher value applicable)	Electronic box:	-40 ... +85°C
Temperature resolution:	0,1°C	Relative humidity:	10 - 95%RH, non condensing
Response time:	150 ms (95%)	Vibration (meas. head):	
Emission-, transmission factor:	adjustable from 0.100 to 1.100	IEC 68-2-6:	3G, 11-200 Hz, each axis
Output signals:	0-20mA, 4-20mA, 0-5V, 0-10V thermocouple type J or K	Shock (meas. head):	
Output impedance:		IEC 68-2-27:	50G, 11ms, each axis
mA	max. 500Ohm (at 8-36VDC)	Weight (meas. head / elec. box):	40g / 420g
V	min. 100 kOhm load resistance	Dimensions electronic box:	120 x 70 x 30mm
Thermo couple:	20 Ohm		
Supply voltage:	8 - 36 VDC		
Power consumption:	max. 100 mA		
Cable length:	1m (standard), 3m, 15m		

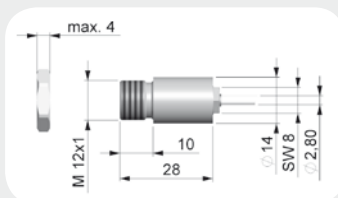

Further special design types (e.g. for metal processing, or with other optics) up on request

Optic resolution (standard)

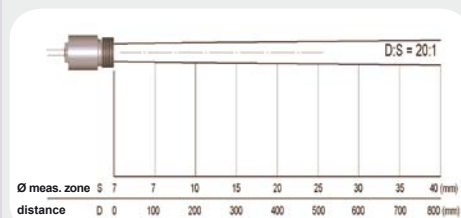

Optic resolution (with option CF)

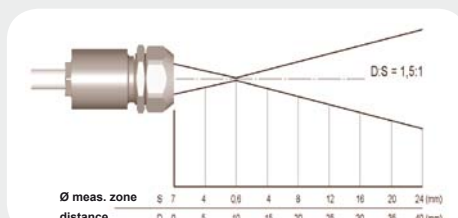

Option

- **CB3** 3m sensor head cable
- **CB15** 15m sensor head cable
- **CF** auxiliary lens for measuring of smallest objects measuring zone dia 0,6mm @10mm, in long distance 1,5:1

Calibration

- **WPS** calibration certificate 23°C, 110°C, 510°C

Mechanical accessories

- **MW** mounting bracket, fixed
- **MB** mounting bolts with M12x1 thread
- **MG** mounting fork, adjustable in 2 axis with M12x1 mount
- **FVS** standard blow clear header
- **FVL** laminar blow clear header

Temperature Switch



TF1 ...

General

A totally sealed bimetal thermostat opens or closes when the pre-fixed switch value is overrated or undercut.

Sensor has to be fully wetted. Switch value is indicated for increasing temperature 2K/min.

TF1 thermostats just monitor the temperature. A regulation is due to the huge hysteresis not possible.

- optional installation
- compact dimensions
- n.o. or n.c. position
- metering substances: water, gas/air, oil

Specifications

Switch value: (declared when placing order)

40°C	Order Nr.: TF1 40
50°C	Order Nr.: TF1 50
60°C	Order Nr.: TF1 60
70°C	Order Nr.: TF1 70
80°C	Order Nr.: TF1 80
90°C	Order Nr.: TF1 90
100°C	Order Nr.: TF1 100
110°C	Order Nr.: TF1 110
120°C	Order Nr.: TF1 120
130°C	Order Nr.: TF1 130

Hysteresis:	10 ... 20 K
Accuracy:	±10 K
Media Temp.:	max. switch value +50°C
Connection:	G1/2A male thread socket brass
Pressure (PN):	100 bar
Electr. data:	NO (NC upon request) 250 V AC, 10 A plug EN 175301-803/A
Weight:	120 g
Protection class:	IP65

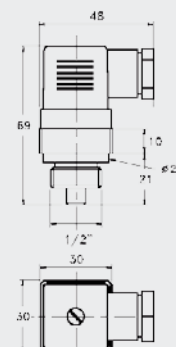

humidity and humidity/temperature transducer

GRHU ... MP and GHTU ... MP

General

The newest generation of humidity/temperature transducer offers even greater possibilities to compensate the special sensor characteristics due to the newest micro-processor technology. Regarding precision, temperature stability and functionality a new dimension is entered.

The transducer can be used for almost all applications due to the different types (e.g. wall or channel mount, with separated probe or with heat absorption hat) and the wide temperature range (electronic: -25°C...+50°C; sensor: -40...+120°C).

- on-site display for humidity and temperature
- output ranges freely scaleable
- temperature range up to 120°C
- adjustment by operator possible
- output signals for humidity and temperature are electrically isolated
- available output signals: 4-20mA, 0-1V or 0-10V

Specification

Measuring ranges:

Humidity: 0,0 ... 100,0 %RH (temperature compensated)
 Temperature: -40,0 ... 120,0 °C or -40,0 ... 248 °F

Recommended humidity range: 20,0 ... 80,0 %RH (standard)
 5,0 ... 95,0 %RH (with option high humidity)

Display options: with option UNI an alternative display unit can be shown instead of the humidity measuring value. The unit selection will be done via the interface or at the keyboard.

Wet bulb temperature -27,0 ... 60,0 °C
 Dewpoint temperature -40,0 ... 60,0 °C
 Enthalpy -25,0 ... 999,9 kJ/kg
 Atmospheric humidity 0,0 ... 640,0 g/kg
 absolute humidity 0,0 ... 200,0 g/m³

Accuracy: (at 25°C and in recommended range)

Display: humidity ±2,5 %RH
 temperature: ±0,4 % of meas. value ±0,2 °C
 Add. output signal: each ±0,2 % FS

Temperature compensation: automatically

Output signal: GRHU 1 x 4-20mA (2-wire), freely scaleable
 GHTU 2 x 4-20mA (2-wire), freely scaleable
 option: 0-1V, 0-10V (other output signals upon request)

Connection: 4 - 20 mA (2-wire) note for GHTU:
 output signals are electrically isolated from each other
 for option AV01, AV10: 0 - 1 (10) VDC (3-wire) note for GHTU:
 output signals are not electrically isolated from each other
 for option AV01G, AV10G: 0 - 1 (10) VDC (3- or 4-wire) note for GHTU:
 output signals are electrically isolated from each other

Auxiliary energy: 12 ... 30 VDC or 18 ... 30VDC (for output 0-10V)

Reverse voltage protection: 50V, permanently

Perm. impedance (at 4-20mA): RA [Ω] = (Uv [V] - 12V) / 0.02 A

Permissible load (at 0-1(10)V): RL [Ω] > 3000Ω

Display: approx. 10 mm high, 4-digit LCD-display, alternating humidity and temperature display

Working temperature: -25 to 50°C (electronics)
 Sensor head and tube: -40 to 100°C - for short time up to 120°C

Storage temperature: -25 to 70°C

Relative humidity (electronic): 0 to 95 %RH (non-condensing)
 If there is a risk of condensation due to temperature changes, please use our encapsulated or lacquered types (optionally available).

Housing: ABS (IP65)

Sensor tube: tube 14 mm Ø, with screw-type protection cap

Sensor length: 50 mm (...1R) or 220 mm (...1K, ...2K)
 option: 300mm, 400mm, 500mm

Electric connection: elbow-type plug acc. to EN 175301-803/A (IP65),

Mounting: 4 housing holes for wall mounting or by means of plastic tube clamps for duct mounting

Functions: min-/max-value memory, offset and slope adjustable, output signal scaleable

Order code (examples)

GHTU-2K-MP / AV10, FL300: GHTU-2K-MP, 0-10V, FL = 300 mm

GRHU-MP / KABEL, HO: GRHU-MP, with separated sensor tube and high humidity sensor

Design types

Surface mounting

Sensor tube at the side
 Tube Length: 50mm

Design type: ...-1R



Duct mounting

Sensor tube at the side
 Tube Length: 220mm

Design type: ...-1K



Duct mounting

Sensor tube downwards
 Tube Length: 220mm

Design type: ...-2K



Prices - humidity transducer

GRHU - 1R - MP (sensor tube at the side, FL = 50mm)

GRHU - 1K - MP (sensor tube at the side, FL = 220mm)

GRHU - 2K - MP (sensor tube pointing downwards, FL = 220mm)

Prices - humidity / temperature transducer

GHTU - 1R - MP (sensor tube at the side, FL = 50mm)

GHTU - 1K - MP (sensor tube at the side, FL = 220mm)

GHTU - 2K - MP (sensor tube pointing downwards, FL = 220mm)

Options / upcharges

- HO: High-humidity sensor upcharge:
 (for humidity measuring < 20 %RH and > 80 %RH)

Note: Upon ordering the range of application can be stated, for this the device will be optimised free of charge (e.g. 10-40% or 60-90%).

- UNI: selectable humidity display unit upcharge:

- LACK: Encapsulated PC board upcharge:
 (for outdoor application, i.e. applications where condensation is possible)

- FL300, FL400, FL500: upcharge:
 (Extra long sensor tube - no interim lengths possible)

- AV01: output signal 0-1V (note: please refer to connection) upcharge:

- AV01G: output signal 0-1V (note: please refer to connection) upcharge:

- AV10: output signal 0-10V (note: please refer to connection) upcharge:

- AV10G: output signal 0-10V (note: please refer to connection) upcharge:

- KABEL: with separated sensor tube upcharge:
 Sensor tube (Ø14x 68mm) connected to device via 1m teflon cable.
 Inclusive option high-humidity sensor
 (Ordering note: specifying the design type (e.g. -1R) is unnecessary)

- SHUT: heat absorption hat / weather protection shield upcharge:
 (Ordering note: specifying the design type (e.g. -1R) is unnecessary)



Application:

The heat absorption hat is especially designed for measurements in the open air. The measuring results that can be achieved will not be influenced by either sun or rain.

Design:

Heat absorption hat made of plastic, dia 110 mm, approx. 140 mm high. Additionally equipped with a stainless steel base for wall mounting, with 3 fixing holes for screws with a max. shaft Ø of 5 mm. Large projection approx. 160 mm.

Spare / accessory parts

Spare protection cap with stainless steel gauze (105µm mesh size) - for standard and high humidity use

Bronze filter (not for use in high humidity)

Air flow measuring transducer



GSMU 1020 B5 GSMU 1020 C5

Properties

- 3 measuring ranges integrated in each device
- selection between 2 different response times
- high accuracy
- almost independent of flow direction
- shock resistant
- resistant to pollution

Application

- air conditioning and ventilation technology
- process and environmental technology

Measuring principle: no moving parts. Hot-film anemometer principle.

Specification

Measuring range flow:

GSMU 1020.: 0...10 m/s, 0...15 m/s and 0...20 m/s
Measuring range can be set by means of jumper.

Output signal: 0 - 10 Volt (Iout < 1.0 mA) or
4 - 20 mA (Ri < 450 Ohm)

Measuring range can be set by means of jumper.

Measuring accuracy: (at 20 °C, 45 %RH, 1013 hPa)

GSMU 1020: 0 ... 10 m/s: ± 0,2 m/s ± 3 % of measured value
0 ... 15 m/s: ± 0,2 m/s ± 3 % of measured value
0 ... 20 m/s: ± 0,2 m/s ± 4 % of measured value

Response time: T₉₀ (at 10 m/s): typ. 4 s or 0.2 s

Response time can be set by means of jumper.

Dependency on flow direction: < 3 % of measured value at $\Delta\alpha < 10^\circ$

Voltage supply: AC / DC ±20%, max. 150 mA

max. load: 500 Ohm

Connection: screw-type terminals up to 1.5 mm²

Operating temperature: -10 ... +50 °C

Storage temperature: -20 ... +60 °C

Housing: 80 x 80 x 35 mm (H x W x D)

Material: ABS

Protection rating: IP65 (electronic box)

Sensor tube: length = 200 mm (+18 mm for sensor head), Ø 12 mm

GSMU...B5: sensor tube permanently connected to housing

GSMU...C5: sensor tube connected to housing via cable (approx. 1 m long)

Other tube or cable lengths upon request.

EMC: Conforming to CE acc. to DIN EN 50081-1 and DIN EN 50082-2

Accessories

GNG 24/150 power supply: 24 Vdc, 150 mA

GNT 0520 mains transformer: 230V~ to 24V~,
with mounting clamp and screw-type terminals.
Dimensions approx. 62 x 56 x 32.5 mm

Miniature Air Velocity Transmitter



GSMU 575

Properties

The transmitter is for measuring air velocity. The measurement method is based on the hot-film anemometer principle, for that purpose, a special thin-film sensor element has been developed. An accurate and reliable determination of the air velocity depends on the correct positioning of the sensor probe in the air stream. Accurate measurements are only possible if the sensor probe is installed where there is no turbulence.

Application

- heating, ventilating
- air conditioning technology
- supply air control of ovens

Specification

Working range: 0...20 m/s

other upon request

Output signal: 0...10 V (max. 1 mA)

Accuracy Velocity: at 20°C / 45 % RH, 1013 hPa, at 1...20 m/s
1...20 m/s: ±(0,4 m/s + 6% of m.v.)

Response time: (bei 10m/s T₉₀) typ. 4 s

Power supply: 19...29 V DC

Power consumption: max. 70 mA bei 20 m/s

Temperature range: working temperature: -20...60°C

storage temperature: -30...60°C

Connection: 0,5 m cabel, PVC 3 x 0,25 mm²,
wire end ferrule

Electromagnetic Compatibility: EN61326-1

EN61326-2-3

Housing: polycarbonate, Lenght: 120 mm, Ø 12 mm

Protection class: IP20 (measuring head), IP40 (housing)

Accessories

GNG 24/150 power supply: 24 V DC, 150 mA

Pressure measuring transducer for absolute pressure, over/under pressure and pressure difference

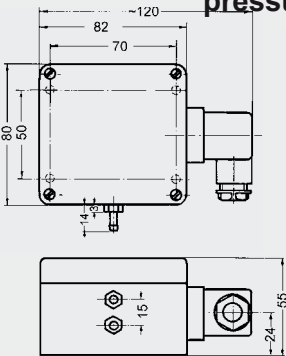

picture shows relative pres. GMUD

GMUD standard pressure range

GMUD fine pressure range (0 to 1 ... 25 mbar)

Application: for air, non-corrosive, non oxidising and non-reducing gases and liquids. Not suitable for water! Suitable for controlling, measuring and monitoring on the climatic/ventilation, environmental and medical technology sector. For use in water an air cushion or hydrophobic filter is required - please contact us.

Types of pressure: ABSOLUTE PRESSURE (vacuum used as reference) for measuring over pressure over absolute zero (sensor displaying barometric air pressure when coming into contact with atmospheric pressure). RELATIVE PRESSURE (reference atmosphere or ambient pressure) for over/under pressure measurements and pressure difference measurements. (Sensor displaying zero when coming into contact with atmospheric or ambient pressure).

Specification:

Sensor element: piezoresistive pressure sensor with integrated temperature compensation 0 to 70°C

Measuring ranges: (standard)

Absolute pressure:	0 to 1100 mbar (e.g. barometric air pressure)
	0 to 2 bar
	0 to 7 bar
Relative pressure:	0 to 70 mbar
	0 to 2 bar
	0 to 10 bar

OPTION: any intermediate values upon request

Overload and bursting pressure:

Meas. range:	70 mbar	1100 mbar	2 bar	7 bar / 10 bar
Overload:	1,3 bar	2 bar	4 bar	10,34 bar

Typ. accuracies:

±0.2% FS (hysteresis and linearity), ±0.4% FS (temperature effect 0 - 50°C) at meas. range ≤ 25mbar; ±0.6% FS (temperature effect 0 to 50°C)

OPTION: double accuracy for meas. range >25 mbar - against upcharge

Output signal: 4 - 20 mA (0-10V against upcharge)

Auxiliary energy: Vs = 12 ... 30 V DC (at 0-10V: Vs = 18 ... 30 V DC)

Permissible impedance (at 4-20mA): $RA [\Omega] = (Vs [V] - 12V) / 0.02A$

Permissible load (at 0-10V): $RL [\Omega] > 3000\Omega$

Operating temperature: 0 ... +70 °C

Storage temperature: -45 ... +70 °C

Pressure connection: 1 (at abs.) bzw. 2 (at rel.) metal connection pieces (nickel plated) for plastic tube 6 x 4 mm (4 mm inner diameter)

Mounting position: any position (small ranges up to 10 mbar depending on position)

Housing: ABS (IP65)

Fixing: by means of fixing holes for wall mounting (accessible after cover has been removed)

Mounting distance: 70 x 50 mm (H x W)

Fixing screws: max. shaft Ø 4 mm

Electric connection: elbow-type plug conforming to EN 175301-803/A (IP65); max. wire cross section: 1.5 mm², wire/cable Ø: 4.5mm to max. 7mm

Prices options:

AV010: option output signal 0-10V upcharge:

MB...: option any measuring range upcharge:
(please state desired measuring range - no upcharge at fine pressure ranges)

LACK: option "encapsulated PC board" upcharge:
(for outdoor application)

DSG: option double sensor accuracy
(not possible for high-precision range!)

VO: option on-site display upcharge:
(for output signal 4-20mA, auxiliary energy Uv = 17 ... 30 V DC)

For suitable tubes, accessories p.r.t. page 42 and 43

pressure measuring transducer 4...20 mA or 0...10 V



GMDP standard pressure range

GMDP fine pressure range (0 to 1 ... 25 mbar)

Application: for air, non-corrosive, non oxidising and non-reducing gases and liquids. Not suitable for water! Suitable for controlling, measuring and monitoring on the climatic/ventilation, environmental and medical technology sector.

Types of pressure: ABSOLUTE PRESSURE (vacuum used as reference) for measuring over pressure over absolute zero (sensor displaying barometric air pressure when coming into contact with atmospheric pressure). RELATIVE PRESSURE (reference atmosphere or ambient pressure) for over/under pressure measurements and pressure difference measurements. (Sensor displaying zero when coming into contact with atmospheric or ambient pressure).

Specification:

Sensor element: piezoresistive pressure sensor with integrated temperature compensation 0 to 70°C

Measuring ranges: (standard)

Absolute pressure:	0 to 1100 mbar
	0 to 2 bar
	0 to 7 bar
Relative pressure:	0 to 70 mbar
	0 to 2 bar
	0 to 10 bar

OPTION: any intermediate values (under pressure also possible) against upcharge available upon request: e.g. ±1bar, 0 bis 350mbar, 0 to 10mbar, etc.

Overload and bursting pressure:

Meas. range:	70 mbar	1100 mbar	2 bar	7 bar / 10 bar
Overload:	1,3 bar	2 bar	4 bar	10,34 bar

Sensor accuracy (typ. values):

±0.2% FS (hyst. and linearity), ±0.4% FS (temperature effect from 0 to 50°C) at meas. range ≤ 25mbar; ±0.6% FS (temperature effect 0 to 50°C)

OPTION: double accuracy for meas. range >25 mbar - against upcharge

Output signal: 4 - 20 mA (0-10V against upcharge)

Auxiliary energy: Vs = 12 ... 30 V DC (at 0-10V: Vs = 18 ... 30 V DC)

Permissible impedance (at 4-20mA): $RA [\Omega] = (Vs [V] - 12V) / 0.02A$

Permissible load (at 0-10V): $RL [\Omega] > 3000\Omega$

Operating temperature: 0 ... +70 °C

Storage temperature: -45 ... +70 °C

Relative humidity: 0 ... 80 % r.h. (non-condensing)

Pressure connection: 2 plastic connection pieces for plastic tube 6 x 4 mm (4 mm inner diameter)

Mounting position: any position (small ranges up to 10 mbar depending on position)

Design-type: electronic PC board cpl. with sensor, 56 x 70 x 33 mm (BxHxT)

Mounting: 4 holes, 3.5 mm Ø each

Mounting distance: 43,5 x 58 mm (W x H)

Electric connection: screw-type/plug-in terminal

Order code:

GMDP 0...1100 mbar abs. / DSG:

GMDP, 4-20mA = 0...1100 mbar abs., double sensor accuracy

GMDP -1.. 10 bar rel. / AV010, LACK:

GMDP, 0-10V = -1 to 10 bar rel., encapsulated PC board

Prices options:

AV010: option output signal 0-10V upcharge:

MB...: option any measuring range upcharge:
(please state desired measuring range - no upcharge at fine pressure ranges)

LACK: option "encapsulated PC board" upcharge:

DSG: option double sensor accuracy
(not possible for high-precision range!)

For suitable tubes, accessories p.r.t. page 42 and 43

Pressure transmitter

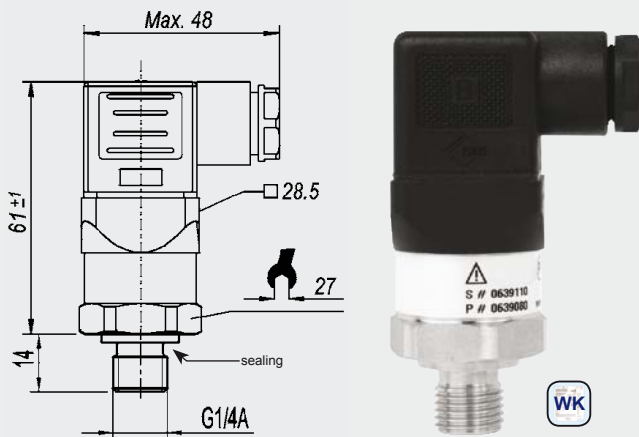

A-10

(relative pressure, zero output at atmospheric pressure)

Option: Absolute Pressure

(0...1bar abs. to 0...25bar abs.)

Option: Under Pressure

(-1,0 ... +1,5 bar, -1,0 ... +3,0 bar, -1,0 ... +9,0 bar)

General application: Suitable for all applications in machine and systems engineering, automotive technology as well as cooling and air conditioning technology.

Specification:

Measuring range (MR), Overload limit (OL), Burst pressure (BD):

MR: 1, 1.6, 2.5, 4, 6, 10, 16, 25, 40, 60, 100, 160, 250, 400, 600

OL: 2 3.2 5 8 12 20 32 50 80 120 200 320 500 800 1200

BD: 5 10 10 17 34 34 100 100 400 550 800 1000 1200 1700 2400

Output signal: 4-20mA, 2-wire, $RA [\Omega] \leq (U_v [V] - 8V) / 0.02 A$
0-10V, 3-wire, $RA \geq 10 k\Omega$
(other output signals upon request)

Auxiliary energy: 8...30VDC (for output 4-20 mA)

14...30VDC (for output 0-10V)

Accuracy: * $\leq 1,0 \% FS$ (optional: $\leq 0,5 \% FS$)

(* including non-linearity, hysteresis, zero point and scale error. Corresponds to error of measurement per IEC 61298-2. Sensor adjusted in vertical mounting position with lower pressure connection)

Non-Linearity: $\leq 0,5 \% FS$ (optional: $\leq 0,25 \% FS$)

Zero Offset: $\leq 0,5 \% FS$ (typ.), $\leq 0,8 \% FS$ (max.),
(optional: $\leq 0,15 \% FS$ (typ.), $\leq 0,4 \% FS$ (max.))

Hysteresis: $\leq 0,16 \% FS$

Repeatability: $\leq 0,1 \% FS$

Long-term drift: $\leq 0,1 \% FS$ (according to IEC 61298-3)

Response time: $T_{90} \leq 4 ms$

Perm. temperature of meas. media: 0 ... +80 °C (optional: -30 ... +85 °C)

Ambient temperature: 0 ... +80 °C (optional: -20 ... +80 °C)

Storage temperature: -20 ... +80 °C

Temperature compensated area: 0 ... +80 °C

Temperature error in comp. area: $\leq 1,0 \% FS$ (typ.), $\leq 2,5 \% FS$ (typ.)

Material: Parts coming into contact with pres. media

- Pressure connection: 316 L

- Pressure sensor: 316 L (as of 10bar rel. 13-8 PH)

Housing: 316 L

Pressure connection: G 1/4 A, DIN 3852-E with NBR sealing

Protection rating: IP65 resp. IP67 with cable

Electric connection: elbow-type plug acc. to EN 175301-803/A or connection cable, cable length 2m

Electric protections: reverse voltage and short-circuit protection

Weight: approx. 150 g

Options, Accessories:

Higher sensor accuracy (class 0,5)

Extended temperature range

Output signal 0-10 V

Fixed connecting cable, 2 m with bend protection
(instead of elbow-type plug, IP67)

GWA1214 V4A thread adapter G 1/2"

with internal thread G 1/4" and external thread G 1/2"

Pressure measuring transducer for over/under and absolute pressure

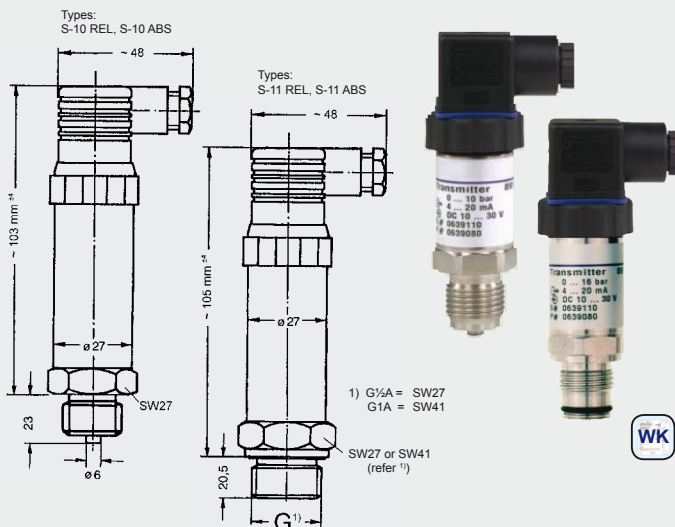

S-10 REL

(Standard, zero output at ambient pressure)

S-11 REL

(Flush, zero output at ambient pressure)

S-10 ABS

(Standard, absolute, zero output at vacuum)

S-11 ABS

(Flush, absolute, zero output at vacuum)

Description: piezoresistive pressure sensor with temperature compensation. Completely welded and stainless steel design, filled food safe (up to 16 bar), thin film strain (above 25 bar).

Specification:

Meas. ranges: in bar (other values upon request)

S-10 REL and S-11REL: 0.1, 0.16, 0.25, 0.4, 0.6, 1, 1.6, 2.5, 4, 6, 10, 16, 25, 40, 60, 100, 160, 250, 400, 600, 1000

S-10 ABS and S-11ABS: 0.25, 0.4, 0.6, 1, 1.6, 2.5, 4, 6, 10, 16

Measuring range (MB), Overload limit (ÜL):

MB (bar): 0.1, 0.16, 0.25, 0.4, 0.6, 1, 1.6, 2.5, 4, 6, 10, 16, 25 ... 600, 1000

ÜL (bar): 1 1.5 2 2 4 5 10 10 17 35 35 80 2x MB 1500

Output signal: 4-20 mA (0-10 V - refer to options; others upon request)

Permissible impedance: $RA [\Omega] = (U_v [V] - 10 V) / 0.02 A$ (for output 4-20 mA)
 $RA [\Omega] > 10 k\Omega$ (for output 0-10V)

Auxiliary energy: 10...30 V DC (14...30 V DC for output 0-10V)

Accuracy:

deviation from parameter (% of span): $\leq 0,5$ (setting of cut-off point)

$\leq 0,25$ (setting of tolerance band, BFSL)

Repeatability (% of span): $\leq 0,05$

Stability / year (% of span): $\leq 0,2$ (at reference conditions)

Hysteresis (% of span): $\leq 0,1$

Permissible temperature of media: -30 ... +100 °C (refer to options)

Operating temperature ambient: -20...+80 °C

Compensated temperature range: 0...+80 °C

Temperature coefficient: $\leq 0.02\% FS / K$ (or $< 0.04 \% FS$ for MB < 0.25 bar)

Filling: KN77, food safe

Housing: stainless steel 1.4435 (IP65)

Pressure connection: (other upon request)

Type S-10... : G 1/2 B

Type S-11... : G 1 B (up to 1.6 bar), G 1/2 B (from 2.5 to 600 bar)

Mounting position: any

Electric connection: standard via elbow-type plug EN 175301-803/A

Electric protections: reverse voltage protection, over voltage and short-circuit protection.

Options:

Special measuring range

upcharge:

-40...+125 °C (media temperature)

upcharge:

-20...+150 °C (media temperature, S-11 only)

upcharge:

Output signal 0-10V (other upon request)

upcharge:

Ex-protection

upon request

CO-Transducer



with TÜV certificate acc. to VDI 2053 for CO surveillance systems in underground garages etc.

GT1 - CO

Properties

High quality, TÜV certified CO transmitter for detection of carbon monoxide in underground garages, parking garages, boiler plants, heating systems, garages as well as in the ambient air.

The CO transducer has a very long-lasting electrochemical measuring cell and could be easily integrated in existing CO surveillance systems (without loss of validity of existing TÜV certificates).

Via two-wire system, displays, controller and alarm devices with 4-20 mA input could be connected without any problem.

Range of Application:

- underground garages, parking garages
- boiler plant and heating systems
- motorcar garage

Highlights:

- TÜV certification according to VDI 2053
- also suitable as replacement sensor for existing CO surveillance systems
- long-lasting electrochemical measuring cell
- automatic zero calibration
- 3 years warranty for the CO sensor element

Specification

Measuring range:	0 ... 300 ppm CO (carbon monoxide)
Measuring principle:	electrochemical, permanent measuring
Reproducibility:	< 3 ppm according to VDI 2053
Response Time T₉₀:	< 60 s
Cross sensitivity:	≤ 2% of 300 ppm CO (acc. to VDI 2053)
Linearity error:	≤ 2% of 300 ppm CO (acc. to VDI 2053)
Offset adjustment:	automatically
Output signal:	4 - 20 mA, 2-wire, max. burden = 500 Ohm
Power supply:	12 - 28 V DC (at option VO: 16 - 28 V DC)
Permissible burden:	RA [Ω] = (U _v [V] - 12 V or 16 V) / 0.02 A
Working condition:	-10 ... +40 °C, 15 ... 95 %RH (non-condensing)
Option: on site display	approx. 13 mm high, 3½-digit LC-display
EMC:	according to EN 50 081-1, EN 50 082-2 B
Electric connection:	elbow-type plug acc. to EN 175301-803/A (IP65), max. wire cross section: 1.5 mm ² , wire diameter from 4.5 to 7 mm
Housing:	ABS, 82 x 80 x 55 mm (without elbow-type plug)
Mounting:	with fixing holes for wall mounting
Mounting distance:	70 x 50 mm (W x H)
Fixing screws:	max. shaft-Ø
Weight:	approx. 190 g

Options / upcharge

VO: on site display

Accessories

GZ-01	test gas cap GT (for controlled flow with test gas)
GZ-02	gas bottle with 12l test gas: 30 ppm CO
GZ-03	gas bottle with 12l test gas: 300 ppm CO
GZ-04	gas valve unit MiniFlo for gas bottles with 12l
GSN 24	plug-in power supply (230V _{AC} => 24V _{DC} /300mA)

additional accessories upon request

CO₂-Transducer



GT10 - CO₂ - 1R

Properties

Due to the fact, that CO₂ is an important indicator for the quality of air in rooms, it's super important to measure the CO₂ content.

The recommended CO₂ limit value for ambient air is 1000ppm. An exceeding of this limit causes tiredness and a loss of concentration.

The high quality and precise CO₂-transducer works according to the infrared principle (NDIR). An auto-calibration procedure compensates aging effects and is responsible for an excellent long term stability of this CO₂ transducer.

Due to the freely adjustable output signal the transmitter could be used for nearly each existing controller input etc..

Additionally, there is a local display which shows beside the actual CO₂ concentration, the minimum and maximum values as well as an optical alarm.

Highlights:

- excellent long term stability
- auto-calibration procedure
- for surveillance of the recommended CO₂ concentration in ambient air
- output signal free scaleable

Specification

Meas. range: standard:	0 ... 2000 ppm CO ₂ (carbon dioxide)
opt. /5000:	0 ... 5000 ppm CO ₂ (carbon dioxide)
Measuring principle:	infrared principle (NDIR)
Accuracy: standard:	±50 ppm ±2 % of meas. value (at 20°C, 1023 mbar)
opt. /5000:	±50 ppm ±3 % of meas. value (at 20°C, 1023 mbar)
Output signal:	4 - 20 mA (3-wire), standard 0 - 1 V or 0 - 10 V (3-wire), optional
Output scaling:	free scaleable, by entering display range
Auxiliary energy:	12 ... 30 V DC, max. 600 mA (at option 0-10V: 18 ... 30 V DC, max. 600 mA)
Perm. burden (at 4-20mA):	RA < 200 Ω
Perm. load (at 0-...Volt):	RL > 3000 Ω
Display:	approx. 10 mm high, 4-digit LC-display
Working condition:	-10 ... +50 °C, 5 ... 95 % r.F., 850 ... 1100 hPa
Storage condition:	-25 ... +60 °C, 5 ... 95 % r.F., 700 ... 1100 hPa
Electric connection:	elbow-type plug acc. to EN 175301-803/A (IP65), max. wire cross section: 1.5 mm ² , wire diameter from 4.5 to 7 mm
Housing:	ABS, 82 x 80 x 55 mm (without elbow-type plug)
Mounting:	with fixing holes for wall mounting
Mounting distance:	70 x 50 mm (W x H)
Fixing screws:	max. shaft-Ø
Weight:	approx. 225 g
Features:	- min-/max-value memory, - optical alarm, - input of offset and scale for adjusting

Options / upcharge

5000: measuring range: 0 ... 5000 ppm CO₂

AV01: output signal 0-1V

AV010: output signal 0-10V

Accessories

GSN 24-750 plug-in power supply (230V_{AC} => 24V_{DC}/750mA)

air oxygen measuring transducer



OXY 3690 MP incl. oxygen sensor GGO370/MU

Specification

Measuring ranges:

oxygen concentration: 0.0 to 100.0 % O₂ (gaseous)
temperature: -20.0 ... 50.0 °C

Accuracy device (at nominal temperature 25°C):

oxygen: ±0.1 % ± 1 digit
temperature: ±0.1 °C ± 1 digit

Output signal (only O₂):

4 - 20 mA (2-wire - standard)
 0 - 10 V (3-wire - option)

Electric isolation:

input electrically isolated

Auxiliary energy:

12 ... 30 V DC (at output 4-20 mA)
 18 ... 30 V DC (at output 0-10 V - option)

Perm. impedance (at 4-20mA):

RA [Ω] = (U_v [V] - 12 V) / 0.02 A

Permissible load (at 0-10V):

RL > 3000 Ω

Working condition:

0 to +50 °C, 0 to +95 %RH (non-condensing)

Storage temperature:

-20 to +70 °C

Reverse voltage protection:

50 V permanently

Display:

approx. 10 mm high, 4-digit LCD-display

Housing:

ABS (IP65 - with the exception of sensor plug)

Dimensions:

82 x 80 x 55 mm (without elbow-type plug and sensor plug)

Electric connection:

elbow-type plug acc. to EN 175301-803/A (IP65),
 max. wire cross section: 1.5 mm²,
 wire diameter from 4.5 to 7 mm

Sensor connection:

5-pin jack connector, screwable

Calibration:

1-point calibration in atmospheric air.

Air pressure compensation:

500...2000 hPa abs., manually input

Oxygen sensor:

GGO 370 / MU

Sensor type:

GGO 370 / MU

Measuring range:

0.0 to 100.0 % O₂

Response time T₉₀:

<10 sec., depending on temperature

Warranty:

12 months (assuming appropriate usage according to the manual)

Application area:

suitable for air and pure oxygen, suitable for high CO₂-concentrations

Temperature compensation:

integrated in oxygen sensor

Connection cable:

approx. 1.3 m, with 5-pin plug, screwable

Operating pressure:

500 ... 2000 hPa (static).

For air and gas-stream use the oxygen sensor GGO.../MU.

Working condition:

-5 to +50 °C, 0 to +95 %RH (non-condensing)

Storage temperature:

-15 to +60 °C

Dimensions of housing:

approx. Ø 40 x 103 mm (153 mm incl. anti-buckling glanding)
 housing with M16x1-screw thread (sensor can be connected to line tubes by means of an included adapter piece)

Weight:

approx. 135 g

Options / upcharge

AV010: output signal 0-10V

GOO: oxygen sensor GGO 370 / MU, open sensor type, suitable for air and gas-stream. (further information p.r.t. p. 51)

KL10: sensor connection cable 10 m

Accessories / spare parts

GOEL 370 spare sensor element for GGO 370 / MU

oxygen measuring transducer for dissolved oxygen in liquids



OXY 3610 MP incl. oxygen sensor

Specification

Measuring ranges:

oxygen concentration: 0.00 to 25.00 mg/l (dissolved)
temperature: 0.0 ... 50.0 °C

Accuracy device (at nominal temperature 25°C):

oxygen: ±1.5 % of m.v. ± 0.2 mg/l
temperature: ±0.1 °C ± 1 digit

Output signal (only O₂):

4 - 20 mA (2-wire - standard)
 0 - 10 V (3-wire - option)

Electric isolation:

input electrically isolated

Auxiliary energy:

12 ... 30 V DC (at output 4-20mA)
 18 ... 30 V DC (at output 0-10V - option)

Perm. impedance (at 4-20mA):

RA [Ω] = (U_v [V] - 12 V) / 0.02 A

Permissible load (at 0-10V):

RL > 3000 Ω

Working condition:

0 to +50 °C, 0 to +95 %RH (non-condensing)

Storage temperature:

-20 to +70 °C

Reverse voltage protection:

50 V permanently

Display:

approx. 10 mm high, 4-digit LCD-display

Housing:

ABS (IP65 - with the exception of sensor plug)

Dimensions:

82 x 80 x 55 mm (without elbow-type plug and sensor plug)

Electric connection:

elbow-type plug acc. to EN 175301-803/A (IP65),
 max. wire cross section: 1.5 mm²,
 wire diameter from 4.5 to 7 mm

Sensor connection:

5-pin jack connector, screwable

Calibration:

1-point calibration: simple quick calibration in atmospheric air.

oxygen sensor (GWO3600MU):

Electrode:

active membrane type, with integrated NTC-resistor

Response time:

95% in 10 sec., depending on temperature

Operation life:

3 years or more, depending on maintenance

Operating pressure:

max. 3 bar.

Flow rate:

min. 30 cm/sec.

Build in diameter:

Ø 12,0 ±0,2 mm (suitable for ½" screw connection)

Overall length:

approx. 220 mm (with anti-buckling glanding)

Build in length:

approx. 110 mm

Connection cable:

approx. 4 m, with 5-pin plug, screwable

Warranty:

12 months

Working temperature:

0 to +40 °C

Scope of supply:

device incl. electrode, GWOK01 and KOH100

Options / upcharge

AV010: output signal 0-10V

Accessories / spare parts

GWO 3600 MU Spare electrode with 4m cable

Upcharge for electrode with 10m cable length

Upcharge for electrode with 30m cable length

GSKA 3600 protection cap for depth measuring

GAS 3600 working set

(consisting of 3 spare diaphragm heads and 100ml KOH-electrolyte)

GWOK 01 spare diaphragm head

per piece

KOH 100 spare electrolyte KOH

100 ml-bottle

pH-measuring transducer with on site display and electrical isolation



GPHU 014 MP / BNC without electrode

GPHU 014 MP / Cinch without electr.

Properties

- automatically and manually temperature compensation
- external Pt1000-temperature probe connectable
- sensor input electrically isolated
- 2-point calibration

Specification

Measuring range:	0.00 to 14.00 pH
Accuracy:	0.02 pH ± 1 digit (at nominal temperature = 25°C)
Output signal:	4 - 20 mA (2-wire), standard 0 - 10 V (3-wire), optional
Electric isolation:	input electrically isolated
Auxiliary energy:	12 ... 30 V DC (for option 0-10V: 18 ... 30 V DC)
Perm. impedance (at 4-20mA):	$R_A [\Omega] = (U_v [V] - 12V) / 0.02 A$
Permissible load (at 0-10V):	$R_L > 3000 \Omega$
Electrode:	any standard pH electrode is suitable. (pH electrode not included in scope of supply)
Input resistance:	$10^{12} \Omega$
Electrode socket:	BNC-socket or Cinch-socket
Temperature compensation:	-30 ... 150°C, manually via 3 keys or automatically via external Pt1000 sensor.
Adjustment:	via 3 keys and integrated LCD
Temp. sensor socket:	2x banana socket $\varnothing 4$ mm, for Pt1000 probe.
Display:	approx. 10 mm high, 4-digit LCD-display
Working temperature:	0 ... +50 °C (electronic)
Storage temperature:	-20 ... +70 °C
Electric connection:	elbow-type plug acc. to EN 175301-803/A (IP65)
Housing:	ABS
IP rating:	IP65, with the exception of electrode and temp. connection sockets. (cpl. IP65 upon request)
Dimensions:	82 x 80 x 55 mm (H x W x D)
Mounting:	with fixing holes for wall mounting
Mounting distance:	70 x 50 mm (W x H)
Fixing screws:	max. shaft- \varnothing

Options / upcharge

AV010:	output signal 0-10V
MB...:	limited measuring range (please state the desired range) (i.e.: 2,00 ... 10,00 pH)

Ordering example

GPHU 014 MP / BNC, AV010:
pH-transmitter with BNC electrode socket and 0-10V output signal

Accessories / spare parts

GTF 2000 WD - B	water proof Pt1000-temperature probe, with 2 banana plugs $\varnothing 4$ mm
for additional Pt1000-temperature probes	p.r.t. page 122, 130-131
GE 100	standard electrode, cinch-plug
GE 117	pH electrode with integrated Pt1000-sensor 1 x BNC-plug and 1 x banana plug $\varnothing 4$ mm, thread PG13,5, pressure resistant up to 6bar
PG 13,5	plug on thread adapter for pressureless use
GAK 1400	working and calibration set (p.r.t. page 35)

for additional electrodes and accessories p.r.t. page 35, 122, 130-131

Redox-measuring transducer with electrical isolation

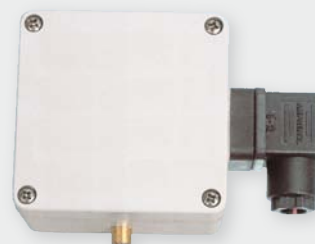

GRMU 2000 MP without electrode

Specification

Measuring range:	± 2000 mV or special limited measuring ranges acc. to customer specification!
Accuracy:	0.2 % FS (at nominal temperature = 25°C)
Output signal:	4 - 20 mA (2-wire), standard 0 - 10 V (3-wire), optional
Electric isolation:	input electrically isolated
Auxiliary energy:	12 ... 30 V DC (for option 0-10V: 18 ... 30 V DC)
Perm. impedance (at 4-20mA):	$R_A [\Omega] = (U_v [V] - 12V) / 0.02 A$
Permissible load (at 0-10V):	$R_L > 3000 \Omega$
Electrode:	redox electrode GE105 (electrode not included in scope of supply!)
Input resistance:	$10^{12} \Omega$
Electrode socket:	Cinch-socket (standard) BNC-socket with upcharge
Option: on site display	approx. 10 mm high, 4-digit LCD-display
Working temperature:	0 ... +50 °C (electronic)
Storage temperature:	-20 ... +70 °C
Electric connection:	elbow-type plug acc. to EN 175301-803/A (IP65)
Housing:	ABS (IP65) with the exception of electrode connection sockets. (cpl. IP65 upon request)
Dimensions:	82 x 80 x 55 mm (H x W x D)
Mounting:	with fixing holes for wall mounting (accessible after removal of cover) Mounting distance: 70 x 50 mm (W x H) Fixing screws: max. shaft- \varnothing 4 mm

Options / upcharge

VO:	on site display
AV010:	output signal 0-10V
BNC:	electrode socket: BNC
MB...:	limited measuring range (please state the desired range)

Ordering example

GRMU 2000 MP / BNC, VO:
GRMU2000MP with BNC electrode socket and on site display

Accessories / spare parts

GE 105	redox electrode with cinch-plug and testing solution
PG 13,5	plug on thread adapter for pressureless use, with external thread PG 13.5 (suitable for any electrode)

For additional electrodes and accessories p.r.t. page 35

Dimensioned sketch GPHU / GRMU

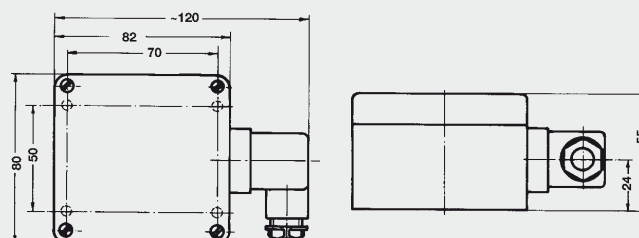

Conductivity measuring transducer



GLMU 200 MP incl. 2-pol meas.cell

Application area

- Easy, low-cost conductivity measurement
- Drink water monitoring
- Fish farming / water monitoring
- Fresh and sea water aquaristics

Properties

- compact conductivity measuring cell
- Output signal freely scaleable
- Adjustable cell constant
- Selectable temperature compensation mode
- On site display for the conductivity or temperature
- Exchangeable unit stickers

Specification

	GLMU 200 MP	GLMU 400 MP
Measuring range: (free selectable by user)		
Conductivity:	0.0 ... 200.0 µS/cm 0 ... 2000 µS/cm 0.00 ... 20.00 mS/cm 0.0 ... 200.0 mS/cm --	0.0 ... 200.0 µS/cm 0 ... 2000 µS/cm 0.00 ... 20.00 mS/cm 0.0 ... 200.0 mS/cm 0 ... 500 mS/cm
specific resistance:	5.0 ... 100.0 kOhm*cm 0.50 ... 10.00 kOhm*cm 50 ... 1000 Ohm*cm 5.0 ... 100.0 Ohm*cm --	0.0 ... 200.0 kOhm*cm 0.00 ... 20.00 kOhm*cm 1 ... 5000 Ohm*cm 1.0 ... 500.0 Ohm*cm 1.00 ... 50.00 Ohm*cm
TDS:	0.0 ... 200.0 mg/l 0 ... 2000 mg/l -- -- --	0.0 ... 200.0 mg/l 0 ... 500.0 mg/l 0 ... 2000 mg/l 0.0 ... 20.0 g/l 0 ... 200 g/l
Salinity:	0.0 ... 70.0	0.0 ... 70.0
Temperature meas.:	-5.0 ... +140.0 °C (transducer) 0.0 ... +80.0 °C (meas. cell)	-5.0 ... +140.0 °C (transducer) 0.0 ... +80.0 °C (meas. cell)
Measuring cell:	2-pole measuring cell	4-pole measuring cell
Standard meas. cell:	conductivity measuring cell with graphite electrodes and integrated temperature sensor. The cell constant is measured and preset ex works. Measuring cell in breakage-protected plastic pole, heat resistant up to 80 °C, Ø12 mm, length of shaft 120 mm, approx. 1 m connection cable. <i>For pressureless applications use the slip-on thread adapter PG13.5. For pressures up to 6 bar order cell with fixed PG13.5 thread (optionally).</i>	

Option / upcharge

- **LTG** for organic matter (alcohol, petrol, diesel) up to max. 1000 µS/cm with glass shaft, unplatinized, 1,35 m PUR-cable



- **PG** electrode with thread PG13.5 (for use up to 6 bar)



GLMU 400 MP incl. 4-pol meas.cell

Application area

- Higher saline concentrations (e.g. brine measuring)
- Measurements in polluted solutions / waste water
- Control of neutralization
- Heavily polluted liquids

Properties

- high-quality conductivity measuring cell, insensitive to dirt
- Output signal freely scaleable
- Adjustable cell constant
- Selectable temperature compensation mode
- On site display for the conductivity or temperature
- Exchangeable unit stickers

Accuracy: (at nominal temperature = 25°C)	Conductivity: ±0.5% of meas. value ±0.3% FS Temperature meas.: ±0.2°C ±1 digit
Meas. cell connection:	7-pole diode connector
Cell constant:	K = 0,30 ... 1,20, freely adjustable
Temperature compensation: (selectable by user)	off: no compensation Lin: linear compensation (from 0.3 ... 3.0 %/K) nLF: non-linear function of natural water according to EN27888 (DIN 38404)
Display:	approx. 10 mm high, 4-digit LC-display
Output signal:	4 - 20 mA (2-wire), standard 0 - 1 V or 0 - 10 V (3-wire), with upcharge
Electric isolation:	input electrically isolated
Auxiliary energy:	12 ... 30 V DC (for option 0-10 Volt: 18 ... 30 V DC)
Reverse voltage protection:	50 V permanent
Perm. impedance (at 4-20 mA):	$RA [\Omega] = (U_v [V] - 12V) / 0.02 A$
Permissible load (at 0-10 Volt):	$RL > 3000 \Omega$
Working temperature:	-25 ... +50 °C (transducer) 0 ... +80 °C (standard meas. cell)
Storage temperature:	-25 ... +70 °C
Electric connection:	elbow-type plug acc. to EN 175301-803/A (IP65)
Housing:	ABS (IP65) with the exception of electrode socket
Dimensions:	82 x 80 x 55 mm, without elbow-type plug and socket
Warranty:	12 months
Mounting:	with fixing holes for wall mounting, Mounting distance: 148 x 50 mm (W x H)

Option / upcharge

- **AV010:** output signal 0-10V
- **AV01:** output signal 0-1V
- **KL=..:** longer meas. cell cable (recommended max. 5m)

Accessories / spare parts

- LFE 202** spare 2-pol measuring cell (for GLMU 200 MP)
- LFE 200** spare 4-pol measuring cell (for GLMU 400 MP)
- PG 13.5** plug on thread adapter for pressureless use
- GKL 100** 100 ml control solution, 1413 µS/cm (pursuant DIN 27888)
- GEH 1** Swivel-arm electrode retainer

Rotational speed sensor proximity switch with analog output



EFFI
EFFU

Properties

The EFFI and EFFU combine a proximity switch with the signal processing to standard signals in one device.

The scaling of the standard signal output can be done at face.

Programming:

- The value for 0 Hz is fixed: 4 mA or 0 V
- For programming the upper output limit (20 mA or 10 V) you have to adjust the max. frequency in the system. By connecting two contacts the device is programmed to this value.

Specification

Measuring principle:	hall-sensor
Sensing distance:	4 mm
Measuring range:	1 ... 4095 Hz
Output signal:	EFFI: 4 - 20 mA (3-wire) EFFU: 0 - 10 V (3-wire)
Sampling interval:	periods measurement, output update 50 ms
Output accuracy:	±0.25 % of full scale
Auxiliary energy:	10 ... 30 V DC (at EFFU: 15 ... 30 V DC)
Idle current:	max. 20 mA (without load)
Electrical connection:	4-pole locking plug M12 x 1 (connection cable see below)
Working temperature:	0 ... 70 °C
Protection class:	IP 67
Housing materials:	nickel plated brass, PA66
Dimensions:	~ Ø 10 x 66.5 mm
Weight:	approx. 25 g

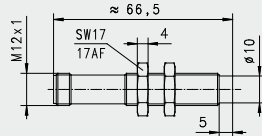

M12 - connection cable



Screened PUR-connection cable with moulded M12x1-connector (and loose ends). Available in straight and angular design.

Versions

KM4P-G02:	straight connector, 4-pole, 2 m cable
KM4P-G10:	straight connector, 4-pole, 10 m cable
KM4P-W02:	90° connector, 4-pole, 2 m cable
KM4P-W10:	90° connector, 4-pole, 10 m cable
KM4P-GL:	connector for self-tailoring, 4-pole

Caloric flow controller



EFK2
EFKP
EFKM

Properties

The flow controllers EFK... monitor liquids and gaseous substances. The instrument combines compact dimensions with a integral probe, a LED trend display (for FLOW) with dual-colour status indicator and an output whose switch-point can be adjusted via a potentiometer.

- no moving parts in the monitored medium
- mounting largely independent of pipe diameter
- low pressure loss
- high working pressures (up to 100 bar)

Area of application

- Metalworking industry: cooling liquid and lubricant monitoring
 - Steel industry: coolant circuits
 - Chemical industry: protection against dry running (for pumps), detection of leaks and fill level monitoring
 - Beverage industry: monitoring of cleaning processes
- Sensors suitable for: Water, oil, aggressive substances

Specification

Measuring principle:	calorimetric
Operating range:	20 ... 50 cm/s (for water)
Display:	EFK2 2-colour LED (red < threshold, green > threshold) EFKP, EFKM 9 LEDs (red - threshold, green 1-8 - flow)
Switch-point adjustment:	via potentiometer
Output:	EFK2 relay contact (max. 30 V / 2 A) NO (open = no flow) Optional: NPN-transistor output (max. 24 V / 100 mA) PNP-transistor output (max. 24 V / 100 mA)
Output:	EFKP, EFKM NPN-transistor output (max. 24 V / 200 mA) Optional: PNP-transistor output (max. 24 V / 200 mA)
Auxiliary energy:	24 V DC ±10 %
Power consumption:	max. 70 mA
Electrical connection:	4-pole locking plug M12 x 1 (connection cable see left)
Working pressure:	max. 100 bar
Working temperature:	15 .. 70 °C
Mounting position:	arbitrary
Protection class:	IP 65 (EFK2), IP 60 (EFKP), IP 67 (EFKM)
Mech. connections:	screw-in thread G1/2A Option: screw-in thread G1/4A
Probe length:	approx. 29 mm (incl. thread)
Materials:	
Probe:	stainless steel 1.4571
Housing:	EFK2: stainless steel 1.4305 EFKP: PA6.6 EFKM: brass, nickel plated
Dimensions:	(without M12-plug) EFK2: Ø 35 x 97 mm (W x H x D) EFKP: 50 x 50 x 95 mm (W x H x D) EFKM: Ø 73 x 81 mm (W x H x D)

Options / upcharges

G1/4A:	device connection G1/4A
PNP:	output: PNP
NPN:	output: NPN

Flow meter (rotor)

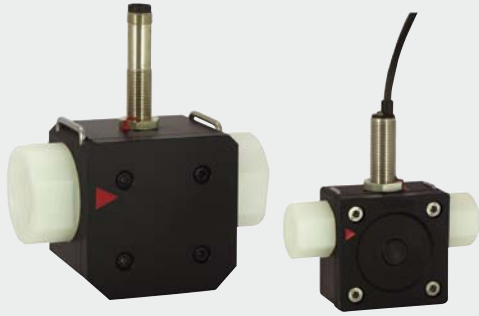

RRI - 010 / ... (DN10, G3/8)

RRI - 025 / ... (DN25, G1)

Properties

The flow meter measures the flow rate with an impeller rotating due to the flow. The flow rate is proportional to the rotational frequency. The rotational speed is measured by an inductive proximity switch.

- no magnets, but with inductive sensor
- largely wear-free due to high-quality ceramic axis and bearing
- output signal NPN (optional PNP)
- no inlet and outflow zone needed
- uncomplicated flow measurement
- intrinsically safe behaviour
- modular design with several connecting systems
- connections plug- and pivotable

Area of application

Sensors suitable for: Water, oil (viscosity up to 10 mm²/s (10 cSt.))

Specification

Measuring principle: rotor (inductive sensor)

Designs:	bore	measuring range	pulse rate* ¹
RRI-010 / 020:	2 mm	(0.1) 0.5 ... 1.5 l/min.	ca. 10200 Imp. / l
RRI-010 / 050:	5 mm	(0.2) 2.0 ... 10 l/min.	ca. 3345 Imp. / l
RRI-010 / 070:	7 mm	(0.4) 2.0 ... 12 l/min.	ca. 1755 Imp. / l
RRI-025 / 080:	8 mm	(2) 3 ... 30 l/min.	ca. 1216 Imp. / l
RRI-025 / 120:	12 mm	(3) 5 ... 60 l/min.	ca. 607 Imp. / l
RRI-025 / 160:	16 mm	(4) 6 ... 100 l/min.	ca. 252 Imp. / l

Accuracy: ±3 % of meas. value (in spec. meas. range)

Repeatability: ±1 % of full scale

Pressure decrease: max. 0.5 bar (at max. flow)

Working pressure: max. 16 bar

Output signal: NPN (optional: PNP)

Auxiliary energy: 5 ... 30V DC, max. 10mA (closed current, without load)

Electrical connection: 2 m cable (optional: 4-pole locking plug M12 x 1)

Working temperature: 0 ... 60 °C

Protection class: IP 67

Mech. connection: nominal bore thread
 RRI-010...: DN 10 G 3/8, female thread *²
 RRI-025...: DN 25 G 1, female thread *²

Mounting position: horizontal or ascending direction of flow

Materials:

Housing: Questra (DN25) / PPS (DN10)

Connection *², rotor: PVDF

Bearing: Iglidur X

Axis: ceramics ZrO₂-TZP

Seal: viton

Dimensions: 84 x 29 x 88 mm (RRI-010...), 110 x 73 x 103 mm (RRI-025...)

*¹ precise value on type plate, max. variability within a batch: ±10 %

*² other thread types (male thread, ...) or materials for connectors upon request

Options / upcharges

PNP: output signal PNP

M12: Electr. connection = plug M12 x 1

Flow switch



FCM - 6 (2,5 l/min)

FCM - 3 (6 l/min)

Properties

FCM flow switch has been designed to offer a very simple and safety control against the missing flow passage. The electrical components are separated from the mechanical parts and the reed contact is magnetically actuated. The switch head is fixed to the body by a fast self locking system and can be replaced without removing the flow switch from the pipe. No adjustment or setting is required after the switch head replacement.

- No setting required
- Easy and fast replacement of the switch head
- Low pressure loss
- Horizontal and vertical mounting
- Liquid and gas applications

Specification

Body	Brass
Process connection	G 1/2"
Sensing element (Piston)	Polypropylen
Accuracy	± 15%
Temperature max.	90 °C
Pressure loss	0,5 bar at max. flow rate
Flow rate max.	25 l/min, for all settings
Weight	170 g
Reed contact	N.O. / No flow condition
Contact rating	300 V, 70 VA, 0,5 A
Wiring	Angle plug
Protection class	IP65

Mounting

Set point l/min	Nominal	ON	OFF
FCM - 6	2,5	2,8	1,7
FCM - 3	6	6,3	4,1

Dimensions

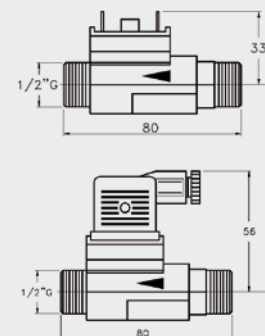

Flow meter for a wide range of applications

(Suitable evaluation devices: GIA20EB, GIR230FR, GIA2000, GIR2002)



FHK

Advantages

- exact measurings of fluid volumes
- long life

Application

alcoholic and non alcoholic drinks, chemicals, water, wine etc.

Specification

Meas. range: approx. 0,03 - 0,58 l/min (other ranges upon request)
Nozzle: D=1 mm.
Pulse rate: approx. 2223 imp./l
Pressure range: max. 20 bar (at 20°C)
Viscosity of media: < 50 cSt.
Meas. accuracy: ±2%
Repetitive accuracy: <0.25%
Power supply: 5-24 V DC; max. 13 mA
Output signal: open collector, NPN
Flow connections: 2 x G¼" IG parallel
Operating temperature: -10 to 100° C
Dimensions: approx. 55 x 40 x 66 mm incl. plug.
Material of housing: ARNITE, turbine: PVDF, sealings: Viton



FH-Messing

Advantages

- sturdy metal housing
- high temperature range
- high operating pressure

Application

Measuring of low-viscous media in beverage and chemical industry etc., such as petrol, fuel etc.

Specification

Meas. range: approx. 0,09 - 1,26 l/min (other ranges upon request)
Nozzle: D=1.5 mm.
Pulse rate: approx. 1450 imp./l
Pressure range: max. 20 bar (at 20°C)
Viscosity of media: < 50 cSt.
Meas. accuracy: ±2%
Repetitive accuracy: <0.25%
Power supply: 5-24 V DC; max. 13 mA
Output signal: open collector, NPN
Flow connections: 2 x G¼" IG parallel
Operating temperature: -10 to 100° C
Dimensions: approx. 55 x 40 x 66 mm incl. plug.
Material of housing: brass chemically nickel plated, sealings: Viton, nozzle: V2A
Scope of supply: cpl. with 2 tube screw-type glandings for internal tube Ø 8mm.



FHK-PVDF

Advantages

- all parts coming into contact with media are plastic
- suitable for chemical and aggressive media

Application

Chemical industry: products containing tensides, alkaline products, acids.
Industry: Monitoring of cooling media circuit at machines, dosing and consumption quantity measurements

Specification

Meas. range: approx. 0,25 - 5 l/min (other ranges upon request)
Nozzle: D=3,3 mm.
Pulse rate: approx. 1033 imp./l
Pressure range: max. 20 bar (at 20°C)
Viscosity of media: < 50 cSt.
Meas. accuracy: ±2%
Repetitive accuracy: <0.25%
Power supply: 5-24 V DC; max. 13 mA
Output signal: open collector, NPN
Flow connections: 2 x G¼" IG parallel
Operating temperature: -10 to 100° C
Dimensions: approx. 54 x 40 x 66 mm incl. plug.
Material of housing: PVDF, sealings: Viton, nozzle: PTFE, axis: PCTFE



EPI

Advantages

- suitable for higher viscous media
- calibratable

Application

chemicals, oil, sirup, liquid soap, catchup, mayonnaise, cleaning agent concentrate, for standardization use

Specification

Meas. range: 0,06 - 5,35 l/min (depending on viscosity)
Nozzle: D=7 mm
Pulse rate: approx. 462 imp./l
Pressure range: max. 10 bar (at 20°C)
Viscosity of media: approx. 5 - 8000 cSt.
Meas. accuracy: ±1% (depending on viscosity)
Repetitive accuracy: < 0.25 %
Power supply: 5-24 V DC; max. 13 mA
Output signal: open collector, NPN
Flow connections: 2 x G¼" IG
Operating temperature: -10 to 65° C
Dimensions: approx. 88 x 68 x 57 incl. plug.
Material of housing: PEEK, sealing: viton



FHKU

Advantages

- suitable for large flow
- low pressure drop
- standard thread connection

Application

Water, acetone, alcohol, ammonia, benzene, vinegar, dilution bases, wine, whiskey, Dosing, and other

Specification

Meas. range: approx. 3 - 26,7 l/min
Nozzle: D=10 mm
Pulse rate: approx. 65 imp./l
Pressure range: max. 20 bar (at 20°C)
Viscosity of media: < 50 cSt.
Meas. accuracy: ±2%
Repetitive accuracy: <0.25%
Power supply: 5-24 V DC; max. 13 mA
Output signal: open collector, NPN
Flow connections: 2 x G1/2" A
Operating temperature: -10 to 100° C
Dimensions: approx. 75 x 43 x 67 incl. plug.
Material of housing: Ryton, sealing: viton



FHKSC

Advantages

- compact device
- measuring of very small quantities
- highly suitable for sucking operations

Application

Beverage industry: wine, spirits, mineral water etc. and chemically slightly aggressive media

Specification

Meas. range: approx. 0,08 - 0,57 l/min.
Nozzle: D=1.2 mm
Pulse rate: approx. 1925 imp./l
Pressure range: -1...+0,3 bar (at 20° C)
Viscosity of media: < 50 cSt.
Meas. accuracy: ±2%
Repetitive accuracy: <0.25%
Power supply: 3.8-20 V DC; <8 mA
Output signal: open collector, NPN
Flow connections: 2 x 6 mm tube connection
Operating temperature: -10 to 65° C
Dimensions: approx. 55 x 40 x 55 mm.
Material of housing: ARNITE, sealing: silicone.

Flow measuring transducer with Hall-effect sensor

for low viscose, non aggressive liquids



VISION 2008

incl. elbow-type plug

Specification

- minimum size, maximum accuracy
- easy installation,
- installation in any position possible
- optimum-quality due to high-quality materials used
- no maintenance

Area of application

- manufacturing of oil and gas burners, flow heaters or cooling systems
- for dish washers and washing machines
- automotive technology (measuring of petro consumption, etc.)
- laboratories, chemical works, pharmaceutical industry
- agriculture and horticulture

Specification

Rotor-position scanning:	Hall-Sensor
Measuring range:	1.5 - 25 l/min
Resolution:	approx. 1000 pulses/l
Measuring agent:	clean liquids, we recommend filtering with approx. 20 to 40 micron
Viscosity:	up to approx. 15 cSt.
Accuracy:	±3% ranging from 10 - 100%
Repeatability:	≤ 0.5%
Working temperature:	-20 to +100°C
Operating pressure:	25 bar
Electric connection:	elbow-type plug acc. EN 175301-803/A, type C industrial
Auxiliary energy:	5 - 24 V DC, approx. 8 mA
Multiplier (R):	1 - 2.2 kOhm
Output signal:	frequency 5 - 416 Hz, open collector NPN
Output current:	max. 20 mA
Dimensions:	approx. 55 x 17 x 30 mm
Material:	
Housing:	Grilamid TR55 (PA12)
Rotor:	Grilamid (PA12 Ferrit)
Bearings:	PTFE 15% graphite
Delivery connection:	G 3/8" thread
DN:	8 mm
Weight:	approx. 15 g

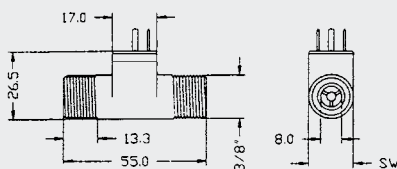

Axial turbine flow sensor for liquids



VTH 25 MS - 180

cpl. with 2 m of cable, ready for plug-in.

General

The flow sensor VTH25MS-180 is a measuring transducer used for measuring the volume flow or for dosing. It is suitable for a wide range of applications due to its compact design, large measuring range and high measuring accuracy.

Area of application

- cooling water measurements, tapping installations, dosing units
- medical technology, plastics industry, laboratory
- solar systems, heating application, heat quantity measurement
- bakery machines, kitchen machines
- machine tools

Specification

Sensor:	Hall-effect-sensor
Measuring range:	4 - 160 l/min, max. 80 l/min with continuous operation (signal emission as of 1 l/min)
Resolution:	approx. 65 pulses / litre
Measuring agent:	liquids
Max. particle size:	0.5 mm
Measuring accuracy:	±3% of measured value
Repeatability:	±0.5%
Working temperature:	Tmax = 85°C
Max. operating pressure:	10 bar
Auxiliary energy:	10 - 30 V DC
Output signal:	frequency, open collector NPN
Output current:	max. 20 mA
Material:	
Duct:	brass
Turbine cage:	PPO Noryl GFN 3V 960
Rotor:	PPO Noryl GFN 2V 73701, with solenoids
Bearings:	sapphire / PA
Shaft:	CrNi-steel (1.4436)
Delivery connection:	R 1 1/4" - outer thread
Nominal width:	DN 25

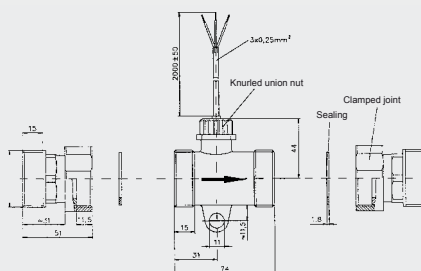

Dimensions in mm

Level Switch Standard Unit



GSS-F25

General

The level switches offer to the user a simple and reliable solution in the liquid level control application. These standard units are available with cable length of 3,0 m.

The working principle is based on the movement of the magnetic float which drives the reed switch inside the level-stem. The cable and switch are epoxy sealed inside the stem and the sealing process is produced by a temperature controlled heating system.

A rugged and free of maintenance product.

- Constructions up to 180°C working temperature on request
- Protection class IP65
- Constructions ATEX on request

Specification

Float	PVDF
Density (S.G.)	≥ 0,65 g/cm ³
Stem	PVDF
Pressure max.	6 bar
Temperature max.	130 °C
Contact	SPST (NO)
Power:	70 VA / 50 W
Voltage:	300 V AC / 300 V DC
Current:	0,5 A AC / 0,7 A DC
Cable	3,0 m
Connection	1/8"
Switching difference:	25 mm
Accuracy Switching point:	±3 mm
Working ambient temp.:	-30/+55°C / RH 90%

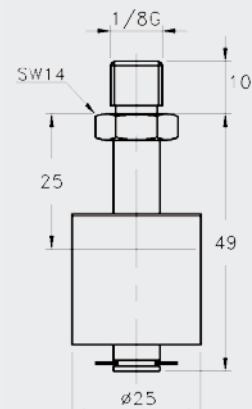

Water level / well probe Tank contents meas. probe



GBS 01

For simple and inexpensive applications. Suitable for permanent level measuring in tanks, rivers, lakes, drinking-water wells, drilling holes, waste water plants...

GBS 02

For measuring the level of fuel and other aggressive media. The sensor is highly precise, insensitive to lateral flow and offers optionally lightning protection and other output signals (e.g. 0-10V). For measuring of gasoline please order ex-design.

Description: piezoresistive pressure sensor with temperature compensation. Welded, non-corrosive design with integral and additionally sealed water-proof connecting cable.

The pressure compensation is done via a cable-integrated air path to the atmosphere. Possible cable lengths up to 300 m. A special feature is the lateral flow resistance, which prevents media ingress. Therefore only the cable has to be replaced in case of a corresponding defect, while sensor is still unharmed.

Specification:

Meas. ranges: 0.1 bar (100 mbar) to 25 bar = 1 to 250 m water column
Available ranges: 0.1, 0.25, 0.4, 0.5, 0.6, 1, 1.6, 2.5, 4, 6, 10, 16, 25
Overload (bar): 1 2 2 2 4 5 10 10 17 35 35 80 80
Output signal: 4-20 mA (option: 0-10 V only for GBS02)
Permissible impedance: 4-20 mA: $R_A [\Omega] \leq (V_s [V] - 10 V) / 0.02 A$
0-10 V: $R_A [\Omega] > 10 \text{ k}\Omega$

Auxiliary energy: 10...30 V DC (14...30 V DC at 0-10 V), others upon request
Accuracy:

GBS01: accuracy (% of span): $\leq 0,5$ (setting of cut-off point) resp. $\leq 0,25$ (BFSL)
GBS02: accuracy (% of span): $\leq 0,25$ (setting of cut-off point) resp. $\leq 0,125$ (BFSL)

(The accuracy of the pressure ranges 0.1 and 0.25bar correspond with the type GBS01)
Hysteresis (% of span): $\leq 0,1$
Repeatability (% of span): $\leq 0,05$
Stability per year (% of span): $\leq 0,2$ (at reference conditions)

Operating temperature: -10...+60 °C (GBS01) or -10...+85°C (GBS02)

Temperature coefficient (% of span): $\leq 0,02 / K$ (for meas. range $\geq 0.4\text{bar}$)

Filling: KN77, food safe

Housing: chromium-nickel alloy 1.4571.

Male thread G 1/2" accessible after removal of plastic protection cap.

Probe dimensions: $\varnothing 27$ mm, length of metal body: approx. 100 mm (GBS01), approx. 147 mm (GBS02), cable \varnothing approx. 7.5 mm

Electric connection: 10 m stationary casted PUR cable (GBS01) resp. FEP-cable (GBS02). Glass-fibre screen protects cable against tearing.

(Extra long cable against upcharge - please specify when ordering)

Options GBS01:

extra long connection cable (PUR) upcharge per m

Optionen GBS02:

extra long con. cable (FEP, teflon) upcharge per m

lightning protection upcharge:

output signal 0-10 V upcharge:

Ex-protection

Device for monitoring the level (capacitive)



- Application for
 - Water
 - Oil
 - Gasoline
 - Solid products as powder or granular
- No moving parts
- Sealed
- High reliability

GNS-SCV-W

Probe for application in water and all conductive liquids

GNS-SCV-Z

Probe for application in oil and all no-conductive liquids

The GNS-SCV capacitive probes are the best way to monitor the level condition of liquids as water, oil gasoline and solid products as powder and granular.

Specification:

Power supply: 12 ... 35 V DC / 5 mA
Electrical output: NPN no-active / max. 3 W
Electrical connection: Plug EN 175301-803/A
Process connection: 1/4" NPT, Brass
Switch delay: 4 sec.
Electrode: Cu-Zn
Electrode coating: PTFE
Electrode length: 50 mm
Switch point: 40 mm \pm 2 mm (vertical mounting)
on the axis of SCV (horizontal mounting)
Pressure max.: 25 bar
Temperature max.: -30 ... +125 °C

Dimensions:

SW	A	B	L0	L1
24 mm	74 mm	10 mm	50 mm	40 mm \pm 2 mm

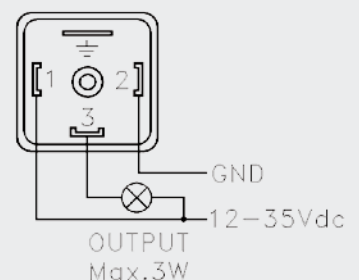
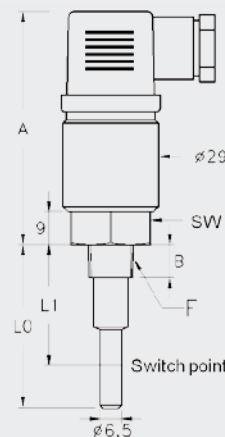

3-pin. probe for level control (conductive)



- Coated electrodes
- Rugged construction, sealed
- EN 175301-803/A plug
- Protection class IP65
- For all industrial, beverage and food applications
- Alarm or level regulation or dosage of liquids
- Combined with control electronics (ALSCHU 300, ALSCHU 485 OE / 3P oder MINAL) an accurate liquids level control system

GNS-3P-SLV

Probe with 3 electrodes with Poliolefin coating suitable for

- cooling water
- all conductive liquids

GNS-3P-SLK

Probe with 3 electrodes with Kynar coating suitable for

- food and beverage industry
- chemical industry

GNS-3P-SLE

Probe with 3 electrodes with PTFE coating suitable for

- aggressive conductive liquids

Specification:

Number of electrodes:	3 Piece
Length of electrodes:	1000 mm
	Probes can be cutted to needed length.
Electrical connection:	EN 175301-803/A Plug
Process connection:	G 1", Polypropylen
Pressure max.:	6 bar
Temperature max.:	+100 °C
Protection class:	IP65

Dimensions:

SW:	40 mm
A:	68 mm
B:	20 mm
L:	500 mm



3-pin. probe for level control (conductive)

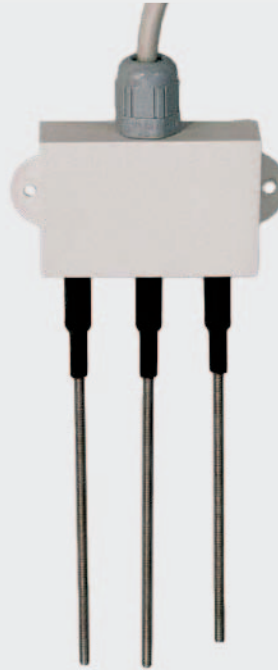

- For all industrial Applications
- Alarm-, Level- und Doseregulation
- Optional teflon covered staffs
- Combined with control electronics (ALSCHU 300, ALSCHU 485 OE / 3P oder MINAL) an accurate liquids level control system

GNS-3P

3-pin. level probe

Please note: for media leaving residues (such as salt water, sewage etc.) we recommend a 3-pin electrode.

Specification:

Number of electrodes:	3 Piece
Length of electrodes:	150 mm
	Other length upon request
	Probes can be cutted to needed length.
Electrical connection:	2 m cable
Switching distance:	10 mm

Options:

other length available

Upcharge each beginning 10cm

Teflon covered staffs

only tip is uncovered (for electrodes used in salt water, ...)

Dimensions:

Elektrodenlänge:	150 mm
Elektroden Durchmesser:	3 mm
Elektronikbox:	55 x 35 mm (B x H)

Accessories:

ALSCHU 485 OE / 3P (p.r.t.p. 137)

Electrode control device connection for 3-pin electrode

ALSCHU 300 ... (p.r.t.p. 137)

Elektrodensteuergerät in 2 Bauformen: Feldgehäuse oder Schnappgehäuse



Level Switch

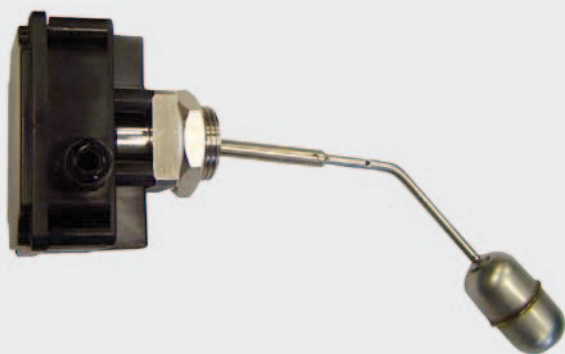

GNS-C1 (with 1 microswitch)

GNS-C2 (with 2 microswitches)

Properties

These level switches offer the most reliable solution for liquid level control where side mounting system is required. The small outlines, the materials and the mounting versatility make this unit one of the level switches more required by the market. The GNS are also suitable for use with process temperature up to 180 °C.

- Switch head magnetically actuated
- 1 or 2 microswitches
- Adjustable stem length
- Brass or AISI-316 construction

Specification

Processconnection:	G1"
Float - S50 (S.G.):	> 0,7 g/cm ³
Pressure max.:	25 bar
Temperature max.:	180°C
Working ambient temperature:	-30/+55°C / RH 90%
Hysteresis max.:	20 mm
Weight:	440 g
Male threads:	Gas parallel UNI 228/1
Body materials:	Natural Brass or Stainless steel (AISI-316)
Float material:	Stainless steel (AISI-316)
Microswitch:	1x or 2x SPDT
Voltage:	250 V AC / 48 V DC
Current:	3A AC / 3A DC
Electr. Connection:	via screw terminals
Wiring:	Independent micro switches separately wired SPDT
Protection Class:	IP65 Housing

Order Example

GNS-C2-O: Level switch with 1 microswitch, Body material Brass

Body Materials

- O Natural Brass
- S AISI - 316

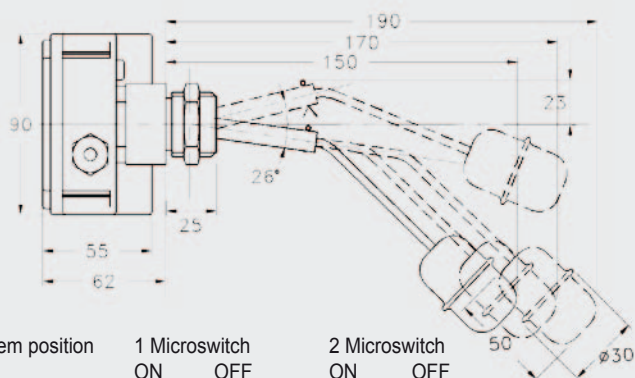

Stem position	1 Microswitch		2 Microswitch	
	ON	OFF	ON	OFF
Long	-46 mm	-63 mm	-32 mm	-49 mm
Medium	-48 mm	-61 mm	-34 mm	-47 mm
Short	-50 mm	-60 mm	-36 mm	-46 mm

Switch point tolerance: ±5 mm

Float switch

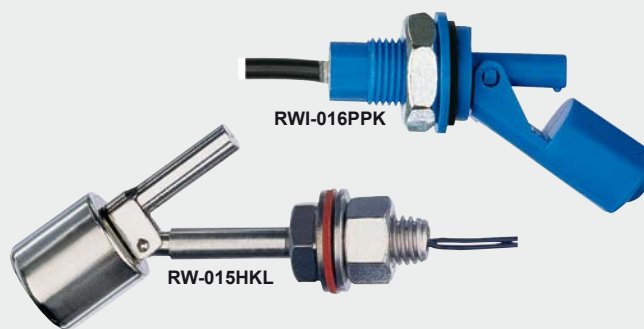

RWI-016PPK (polypropylene)

RWI-016PVK (PVDF)

RW-015HKL (stainless steel)

Properties

Mechanical level controller for liquids. A magnet-equipped float triggers a pre-fixed reed switch.

- wall mounting
- reliable
- good repeatability
- stainless steel design for high temperatures

Area of application

Sensor suitable for: Water, oil,

Specification	RWI-016PPK	RWI-016PVK	RW-015HKL
Measuring principle:	reed switch	reed switch	reed switch
Switch type:	<i>n.c. or n.o depending on installation position</i>		
Switching power:	250 V AC, 0.5 A, 50 VA	250 V AC, 0.5 A, 50 VA	220 V AC, 0.28 A, 30 VA
Density medium:	>0.6 g/cm ³	>0.75 g/cm ³	>0.70 g/cm ³
Working temperature:	max. 90 °C	max. 130 °C	max. 200 °C
Working pressure:	PN = 3 bar	PN = 6 bar	PN = 5 bar
Mounting position:	horizontal	horizontal	horizontal
Protection class:	IP 65	IP 65	IP 65
Electrical connection:	~ 50 cm cable	~ 50 cm cable	~ 60 cm strand
Materials:			
Body:	PP	PVDF	stainl. steel 1.4571
Float:	PP	PVDF	stainl. steel 1.4571
Seal:	viton	viton	
Weight:	approx. 75 g	approx. 75 g	approx. 120 g

Dimensions: RWI-016...

Assembly internally:
Hole diameter Ø16.5 mm

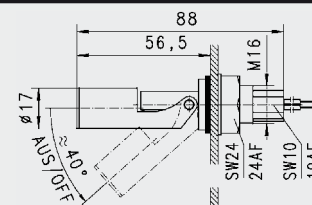

Assembly externally:
Hole diameter Ø23 mm

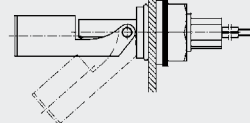

Dimensions: RW-015HKL

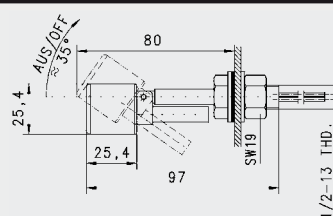

Level transmitter



LC-S45M... (brass) ab

LC-S44M... (brass) ab

LC-K52K... (stainless steel) ab

Final prices depend on type, see price table below

Properties

A magnet equipped float activates a reed chain inside a tube which is connected to resistors comparable to a potentiometer. The gapless positioning of the sensors provides a continuous signal with good resolution (up to 10-20 mm) and repeatability.

- top assembly
- selectable material combinations
- optional: with user-specific characteristic (for adjustment to tank design)

Area of application

Sensor suitable for: Water, oil, aggressive substances (only LC-K52K...)

Specification

Tube length:	250 mm, 500 mm, 750 mm, 1000 mm, 1500 mm and 2000 mm		
Float travel:	..0250	..0500	..0750 ..1000 ..1500 ..2000
LC-S45M... :	190 mm	440 mm	690 mm 940 mm
LC-S44M... :			930 mm 1430 mm 1930 mm
LC-K52K... :	160 mm	410 mm	660 mm 910 mm 1410 mm 1910 mm
Division (resolution):	10 mm (LC-S45..., LC-K52K0250) or 20 mm		
Output signal:	4 - 20 mA (2-wire)		
Optional:	0 - 10 V (3-wire)		
Auxiliary energy	10 ... 30 V DC (at option Flex: 18 ... 30 V DC)		
Electrical connection:	angular connector acc. to EN 175301-803/A (at option Flex: 4-pole locked plug M12 x 1)		
Working temperature:	0 .. 85 °C		
Working pressure:	max. 20 bar (LC-S..), max. 40 bar (LC-K..)		
Density medium:	>0.34 g/cm ³ (LC-S45..), >0.44 g/cm ³ (LC-S44..), >0.66 g/cm ³ (LC-K52..)		
Mounting position:	vertical, float pointing downwards		
Protection class:	IP 65		
Dimensions:	LC-S45..	LC-S44..	LC-K52..
Sensor head:	~50 x 50 x 78 mm	~60 x 58 x 78 mm	Ø 69 x 78 mm
Tube length:	according to design type		
Mounting SW:	SW 40	SW 46	SW 46
Screw-in thread:	G1 A	G1 1/2 A	G2 A
Float:	Ø 30 x 45 mm	Ø 44 x 50 mm	Ø 52 x 70 mm
Materials:			
Housing:	Ms58	Ms58	stainl. steel 1.4571
Tube:	Ms58	Ms58	stainl. steel 1.4571
Float:	Spansil	Spansil	stainl. steel 1.4571

Prices of design types

tube length: ..0250 ..0500 ..0750 ..1000 ..1500 ..2000

LC-S45M...

LC-S44M...

LC-K52K...

Options / upcharges

AV010: output signal 0-10 V

Flex: Transmitter with Flex-head (M12-connection) user-specific characteristic possible

Single contact level switch



GNS-KIT ...

(without rod tube - state when ordering)

Properties

The user can add by himself the level switch in the desired length the rod tube between the process connection and the float contact unit. The float contact unit is under water protected.

- Sealed under water protected contact
- Rod tube in 500 mm / 1000 mm / 1500 mm available state when ordering
- IP65 protection class

Specification

Float-contact unit:	Nickel plated brass
Density:	> 0.35 g/cm ³
Pressure max.:	20 bar
Temperature max.:	105°C
Connection:	1/8"
Reed-contact:	SPDT: 230 V, 60 VA, 1.0 A
Process connection:	Thread G1", Brass
Electrical connector:	Plug EN 175301-803/A
Protection Class:	IP65
Seal:	NBR, oil resistant
Rod-tube:	Ø 8 mm, Brass

Rod-tube (state when ordering)

Rod-tube length:	FL = 500 mm
	FL = 1000 mm
	FL = 1500 mm

Order example: GNS-KIT 1000

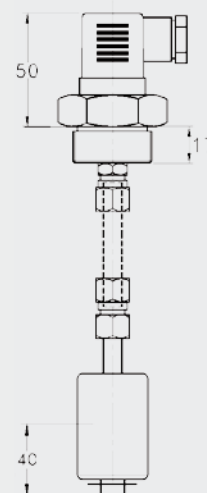

Temperature probes

Handheld instrument

Display / Controller

Logger / EASYBus

Transmitter

Temperature probe

Alarm / Protection

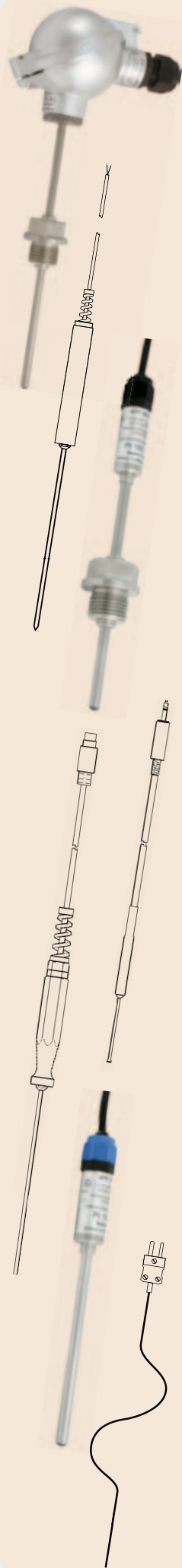

	Connection					Sensor head	Description	Page
	4-pole Mini-DIN-plug	3,5 mm Ø jack connection	Miniature flat-pin plug	Loose ends	Ex - Protection			
Pt100								
GTF ..	✓			✓			Immersion probe for liquids / gases	121
GES ..	✓			✓			Insertion probe for soft media	121
GLF 401 Mini	✓			✓			Probe for measurement of ambient air	121
GOF 401 Mini	✓			✓			Surface probe for solid surfaces	121
Pt1000								
GTF ..		✓		✓			Immersion probe for liquids / gases	122
GES ..		✓		✓			Insertion probe for soft media	122
GOF ..		✓		✓			Surface probe for solid surfaces	122
GLF ..		✓		✓			Probe for measurement of ambient air	122
GGF ..		✓		✓			Probe for deep-frozen products	122
NiCr-Ni (type K)								
GOF ..			✓	✓			Surface probe for solid surfaces	123
GTZ ..			✓	✓			Clip-on probe	123
GTF ..			✓	✓			Immersion probe for liquids / gases	124
GES ..			✓	✓			Insertion probe for soft media	124
GKF ..			✓	✓			Probe for compost grain	124
GAF ..			✓	✓			Asphalt probe	124
GTF 300 ..			✓	✓			Wire probe	125
GMF ..			✓	✓			Magnetic surface probe	125
GGF ..			✓	✓			Probe for deep-frozen products	125
GRF ..			✓	✓			Tire probe	125
GKF			✓	✓			Cable lug probe	125
GLS ..			✓	✓			Soldering tip probe	125
GTT ..			✓	✓			Thermo elements	126
GTF 101 ..			✓	✓			Thermo elements	127
Rt10Rh-Pt (type S)								
GTF ..			✓	✓	✓		Probe for burning kilns	128
NiCrSi-NiSi (type N)								
GTF ..			✓	✓	✓		Probe for permanent high temperatures	128
Silicium (KTY ..)								
GTF ..		✓		✓			Immersion probe	128
GMF ..				✓			Immersion, touching, air probe	128
Freely customized probes (Pt100 / Pt1000 / NiCr-Ni)								
GTF 101 ..			✓	✓		✓	Industrial probes, process connection without thread	129/130
GTF 102 ..			✓	✓		✓	Industrial probes, process connection with thread	129/130
GTF 103 ..					✓	✓	Industrial probes, process connection with / without thread	129/131
GTF 104 ..					✓		Probe with angle plug	131
TF 101 ..			✓	✓			Hermetically sealed probe	132
GOF 1xx ..			✓	✓			Self-adhesive probes	133

Temperature probes

Accuracy:

Pt100 / Pt1000: sensor accuracy acc. to DIN EN 60751

DIN cl. B: (area of validity: -50 ... +500 °C) ±0,3°C at 0°C

DIN cl. A: (area of validity: -30 ... +300 °C) ±0,15°C at 0°C

DIN cl. AA = 1/3 DIN cl. B: (0 ... +150 °C) ±0,1°C at 0°C

1/10 DIN Kl. B: ±0,03°C at 0°C

Thermocouples: sensor accuracy acc. to DIN EN 60584-2

class 1 für Typ K: ±1,5°C at range -40...+375°C

class 1 für Typ N: ±1,5°C at range -40...+375°C

class 1 für Typ S: ±1°C at range 0...1100°C

Special designs (Upcharges):

basic fee for custom made probe

longer probe tube

longer cable (silicone)

other cable material

teflon covered probe tube (for probes up to 200 mm)

(for probes used in acids and salt water, upper temperature range 250 °C)

waterproof probe handle (casted, only possible with PVC cable -20 ... +105 °C)

higher sensor accuracy: 1/3 DIN Kl. B,

for Pt100 and Pt1000,

tolerances: 0,1°C at 0°C

higher sensor accuracy: 1/10 DIN Kl. B,

for Pt100-probes,

tolerances: 0,03°C at 0°C

upcharge per further starting 100 mm

upcharge per further starting meter

upcharge per meter **please refer to cable pricing p. 135**

Please note:

**customized probes have to be ordered in writing!
return or exchange are not possible!**

Pt100 Measuring probe

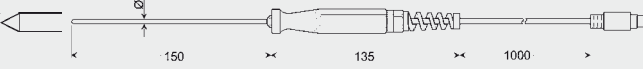
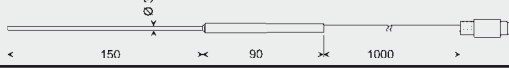
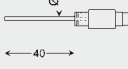
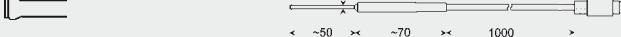
Ordering type Range / DIN Class	Application / Dimensions (mm) techn. specification	Response time T ₉₀	suitable for	Price
GTF 401 -50 ... +400°C DIN cl. B GTF 401 1/3 DIN * -50 ... +400°C GTF 401 1/10 DIN * -50 ... +400°C	Immersion probe for liquids / gases non-corrosive stainless steel tube (V4A), plastic handle, approx. 1 m 4-wire PVC cable, anti-buckling glanding, 4-pin miniature DIN-type plug  as GTF401 however 1/3 DIN class B (±0,1°C at 0°C) as GTF401 however 1/10 DIN class B (±0,03°C at 0°C) and flexible jacket tube, Ø 3mm	approx. 10 sec.	GMH2000(SA) GMH35xx GMH3710 GMH3750	
GES 401 -50 ... +400°C DIN cl. B GES 401 1/3 DIN * -50 ... +600°C	Insertion probe for soft media Specification as for GTF401 but with needle type prod  as GES401 however 1/3 DIN class B (±0,1°C at 0°C)	approx. 10 sec.	GMH2000(SA) GMH35xx GMH3710 GMH3750	
GTF 601 -200 ... +600°C DIN cl. B GTF 601 1/3 DIN * -200 ... +600°C	Immersion probe for liquids / gases, 4-wire handle as per GTF150, approx. 1 m 4-wire PVC cable, 4-pin miniature DIN-type plug, flexible jacket tube, 3mm Ø. (smaller tube diameter upon request) as GTF601 however 1/3 DIN class B (±0,1°C at 0°C)	approx. 10 sec.	GMH2000(SA) GMH35xx GMH3710 GMH3750	
GTF 35 -50 ... +400°C DIN cl. B	Immersion probe for liquids / gases, 4-wire non-corrosive stainless steel tube (V4A), approx. 1 m 4-wire PVC cable, 4-pin miniature DIN-type plug 	approx. 10 sec.	GMH35xx GMH3710 GMH3750	
GLF 401 Mini -25 ... +70°C DIN cl. A GOF 401 Mini -50 ... +200°C DIN cl. B	Fast and accurate Measurement of ambient air Ø 1,6 mm, FL = ca. 40 mm, 4-pin mini. DIN-type plug  Surface probe for solid surfaces, fast 2 x 2.3 mm ceramic Pt1000 sensor mounted at the tip, V4A tube, 4-wire PVC cable with 4-pin miniature DIN-type plug 	approx. 15 sec.	GMH35xx GMH3710 GMH3750	

* Please note the area of validity for the class of accuracy given above.

Pt1000 - Measuring probes, 2-wire

All types of probes also available for Pt100 2- / 3- or 4-wire connection

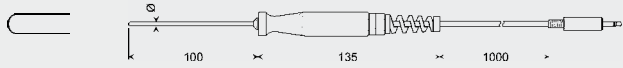
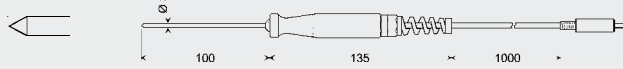
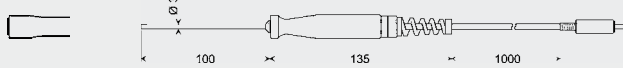
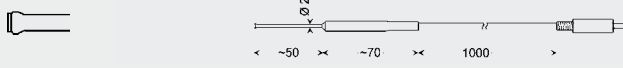
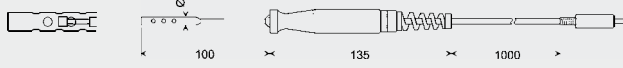
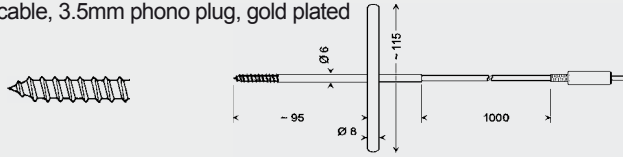
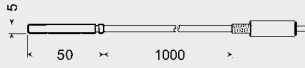
Ordering type Range	Application / Dimensions (mm) techn. specification	Response time T_{90}	suitable for	Price
GTF 175 -70 ... +200°C Pt1000 class B	Immersion probe for liquids / gases non-corrosive stainless steel tube (V4A), plastic handle, anti-buckling glanding, 1m highly flexible silicone cable, 3.5 mm gold plated jack connector 	fluid approx. 10 sec. air approx. 40 sec.	GMH175 GFTH200 ST60, ST80	
GTF 175 LE	like before but with loose cable ends		GIA20EB	
GTF 175 / 1.6 -70 ... +200°C Pt1000 class B	Immersion probe for liquids / gases probe tube: jacket element $\varnothing 1.6$ mm, flexible, other data p.r.t. GTF175	fluid approx. 4 sec. air approx. 25 sec.	GMH175 GFTH200 ST60, ST80	
GTF 175 / 1.6 - LE	like before but with loose cable ends		GIA20EB	
GES 175 -70 ... +200°C Pt1000 class B	Insertion probe for soft media stainless steel tube (V4A) with slim insertion tip, other data p.r.t. GTF175 	approx. 10 sec.	GMH175 GFTH200 ST60, ST80	
GES 175 LE	like before but with loose cable ends		GIA20EB	
GOF 175 -70 ... +200°C Pt1000 class B	Surface probe for solid surfaces S2 x 2.3mm ceramic Pt1000 sensor mounted at the tip. V4A tube, quadratic 3 x 3 mm at the tip, other data p.r.t. GTF175 	approx. 60 sec.	GMH175 ST60, ST80	
GOF 175 LE	like before but with loose cable ends		GIA20EB	
GOF 175 Mini -70 ... +200°C Pt1000 class B	Surface probe for solid surfaces, fast S2 x 2.3mm ceramic Pt1000 sensor mounted at the tip, V4A tube, 1m silicone cable, 3.5 mm gold plated jack connector 	approx. 15 sec.	GMH175 GFTH200 ST60, ST80	
GLF 175 -70 ... +200°C Pt1000 class B	Air/gas probe for clean media (for dirty measurands use GTF175), punched V4A protection tube, fast miniaturized Pt1000 mounted freely in tube, resulting in fast response, other data p.r.t. GTF175 	approx. 15 sec.	GMH175 GFTH200 ST60, ST80	
GLF 175 LE	like before but with loose cable ends		GIA20EB	
GGF 175 -70 ... +200°C Pt1000 class B	Probe for deep-frozen products to screw into deep-frozen products, etc. no predrilling required. Stainless steel (V4A) tube, 6 mm \varnothing with screw prod, flexible silicone cable, 3.5mm phono plug, gold plated 	approx. 15 sec.	GMH175 GFTH200 ST60, ST80	
GTF 2000 -50 ... +200°C Pt1000 class B	Air- / tube mounting probe Probe for diving tube. Tube of stainless steel, highly flexible silicone cable 2 x 0.25 ² , 3.5mm gold plated phono plug 		GMH175 GFTH200 ST60, ST80	
GTF 2000 LE	Customized cable lengths (1m standard), each beginning meter like before but with loose cable ends		GIA20EB	
GTF 2000 WD -20 ... +105°C Pt1000 class B	Air- / tube mounting probe - water proof type Construction like described before, but cable of PVC and tube enclosed water proof, max. 105°C!		GMH175 GFTH200 ST60, ST80	
GTF 2000 WD - LE	like before but with loose cable ends		GIA20EB	

We manufacture all types of probes according to Your special desires - low priced and fast. Please contact us.

NiCr-Ni (Type K) - Measuring Probe

class 1 = highest precision-class according to DIN

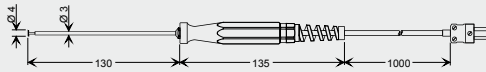
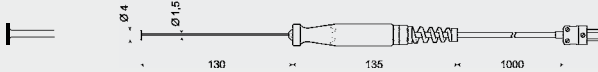
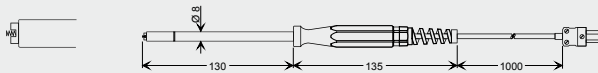
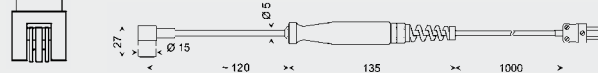
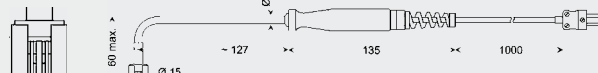
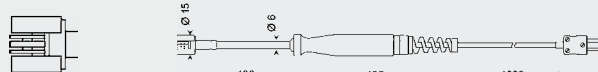
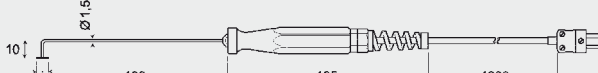
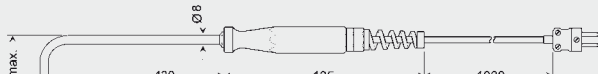
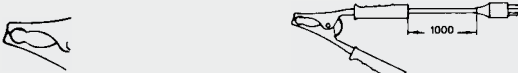

Ordering type	Range °C	Application / Dimensions (mm)	Response time T_{90}	further technical details
GOF 130CU	-65 ... +500°C	Surface probe for straight and solid metal surfaces 	approx. 3 sec.	Spring-loaded copper plate, plastic handle, silicone cable, DIN-type flat-pin plug
GOF 500	-65 ... +500°C	Surface, immersion, air, gas probe for any solid surface 	approx. 5 sec.	Solid copper plate, plastic handle, silicone cable, DIN-type flat-pin plug
GOF 130	-65 ... +900°C	Surface probe for any solid surface 	approx. 2 sec.	2 laser welded NiCr-Ni resilient springs, V4A-tube, plastic handle, silicone cable, DIN-type flat-pin plug
GOF 200HO	-65 ... +400°C	Surface probe for fastest measurements in small gaps 	approx. 2 sec.	Small elbow-type, flexible thermocouple tapes, plastic handle, silicone cable, DIN-type plug
GOF 400HO	-65 ... +400°C	Surface probe for fastest measurements 	approx. 2 sec.	Flexible thermocouple tapes, plastic handle, silicone cable, DIN-type plug
GOF 400VE	-65 ... +400°C	Surface probe for fastest measurements 	approx. 2 sec.	Flexible thermocouple tapes, plastic handle, silicone cable, DIN-type plug Accessories MH 400VE: magnet holder, heat resistant up to 100 °C
GOF 500 HO	-200 ... +500°C	Surface probe for fastest measurements Ø 1,5 MTE (K) Inconel 600 	approx. 5 sec.	Solid copper plate, plastic handle, silicone cable, DIN-type flat-pin plug
GOF 900 HO	-65 ... +900°C	Surface probe for any solid surface 	approx. 2 sec.	2 laser welded NiCr-Ni resilient springs, V4A-tube, plastic handle, silicone cable, DIN-type flat-pin plug
GTZ 300	-65 ... +150°C	Clip-on probe for temperature measurements at tube surfaces 	approx. 3 sec.	for tubes up to approx. 1" Ø, silicone cable, DIN-type flat-pin plug

NiCr-Ni Standard Measuring Probe "Type K" (ctd.)

Probes as Pt100 or Pt1000 upon request

Ordering type	Range °C	Application / Dimensions (mm)	Response time T_{90}	further technical details
GTF 400	-65 ... +550°C	Immersion probe inexpensive, fast, elastic (rigid)	approx. 3 sec.	Stainless steel tube, 1.5Ø, L=130mm, silicone cable
GTF 900	-65 ... +1000°C	Immersion probe inexpensive, elastic (rigid)	approx. 5 sec.	Stainless steel tube, 3Ø, L=130mm, silicone cable (any length against upcharge) each additional 100mm
GTF 1200	-200 ... +1150°C	Immersion probe for High-temperature flexible thermowell	approx. 3 sec.	Inconel 1.5Ø, L=150mm, silicone cable, DIN-type flat-pin plug, electrically insulated
GTF 1200/300	-200 ... +1150°C	Immersion probe flexible thermowell	approx. 5 sec.	Inconel 3Ø, L=300mm, electrically insulated
GTF 1000 AL	-200 ... +1000°C	Immersion probe for aluminium melt, non-ferrous metal, etc.	approx. 30 sec.	V4A tube Ø6x1,4 mm, L=1000mm rigid, plastic handle, 1m silicone cable, DIN-type flat-pin plug, add. internal jacket TC, high lifetime
GES 21K	-50 ... +250°C	Core temperature- / food probe big white teflon handle water- and steam-tight, stainless steel anti-buckling		1 m teflon cable, loose ends, teflon handle Use for canteen kitchen, bakeries, butcher's shops, etc.
GES 130	-65 ... +550°C	Insertion probe for soft media	approx. 3 sec.	Flexible stainless steel (V4A) needle, 1.5 mm Ø, plastic handle, silicone cable, DIN-type flat-pin plug
GES 500	-65 ... +550°C	Insertion probe for soft media	approx. 5 sec.	Flexible stainless steel (V4A) needle, 3 mm Ø, ...
GES 900	-65 ... +1000°C	Insertion probe inexpensive, elastic (rigid)	approx. 5 sec.	Stainless steel (V4A) tube, 3Ø, L=130mm, plastic handle, silicone cable, DIN-type flat-pin plug
GKF 125	-65 ... +200°C	Probe for compost, grain etc. quick response within seconds but also rigid design	approx. 6 sec.	V4A tube 8mm dia. reduced to 3 mm, plastic handle, silicone cable, DIN-type flat-pin plug
GAF 200	-65 ... +550°C	Injection or asphalt probe for liquid or soft media etc.	approx. 6 sec.	V4A tube 8mm dia. reduced to 3 mm, plastic handle, spiral cable stretchable to 1.2m, DIN-type flat-pin plug Upcharge for other probe length
GTL 130	-65 ... +600°C	Air/gas probe (room temperature, smoke gases etc.)	approx. 1,5 sec.	Stainless steel (V4A) tube, plastic handle, silicone cable, DIN-type flat-pin plug

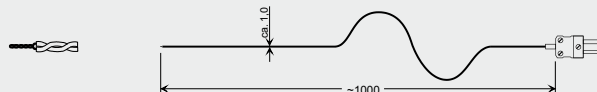
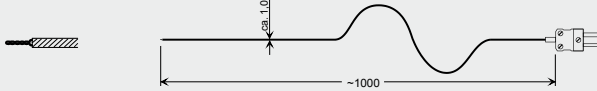
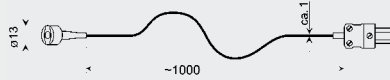
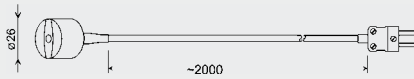
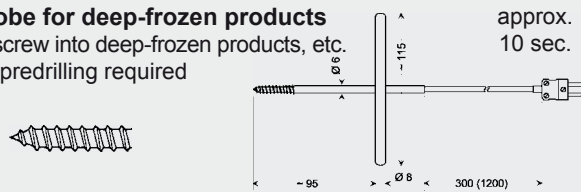
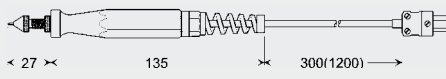
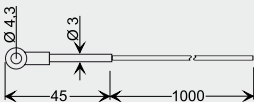
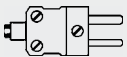
NiCr-Ni Standard Measuring Probe "Type K" (ctd.)

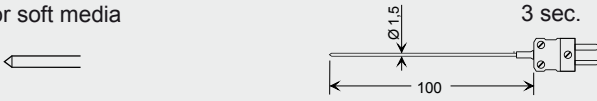
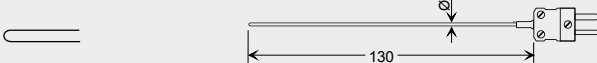
Ordering type	Range °C	Application / Dimensions (mm)	Response time T_{90}	further technical details
GTF 300	-65 ... +300°C	Quick-response measurements in air, liquids, for very small surfaces 	approx. 0,3 sec.	Twisted pair of teflon insulated thermowell wires, 0,2 mm Ø each, welded measuring prod, very flexible, DIN-type flat-pin plug. Any length (up to 50m) against upcharge.
GTF 300 GS	-65 ... +400°C	For high temperatures in gases, air and for solid surfaces (not suitable for liquids) 	approx. 0,3 sec.	Pair of glass fibre insulated thermowell wires, 0,2 mm Ø each, DIN-type flat-pin plug. Upcharge for special length of probe
GMF 250	-65 ... +250°C	Magnetic surface probe sticks at magnetic materials, resilient measuring probe with small metal plate, approx 5mm dia. 	approx. 5 sec.	approx. 1m of twisted teflon insulated wire, DIN-type flat-pin plug
GMF 200	-65 ... +200°C	Magnetic surface probe sticks at magnetic materials, resilient measuring probe with small metal plate, approx 5mm dia. 	approx. 5 sec.	extended type (higher magnetic force), rigid 2m silicone cable, DIN-type flat-pin plug
GGF 200	-65 ... +200°C	Probe for deep-frozen products to screw into deep-frozen products, etc. no predrilling required 	approx. 10 sec.	Stainless steel (V4A) tube, 6 mm Ø with screw prod, spiral cable (approx. 1.2 m drawn out), DIN-type flat-pin plug
GRF 200	-50 ... +200°C	Tire probe fast response insertion probe with stop screw (needle adjustable 0 to 14 mm). Suitable for measuring temperature of tires and other soft media. 	approx. 5 sec.	plastic handle, spiral cable (approx. 1.2m drawn out), DIN-type flat-pin plug
GKF 250	-50 ... +250°C	Cable lug probe 		1 m teflon cable, loose ends
GLS 500	-50 ... +500°C	Soldering tip probe for direct connection to instrument 	approx. 2 sec.	thermo couple springs (~5mm) with laser welded meas. point (wires 0.3 Ø), ceramic tube approx. 6 Ø, DIN-type flat-pin plug
GTO 130 OK	-65 ... +400°C	Air-/Gas probe (changeable probe without cable) limited suitable also for surfaces 		NiCr-Ni-wire 0,5 Ø, welded and grinded flat, V4A-tube, DIN-type flat-pin plug, rigid connection
GTE 130 OK	-65 ... +400°C	Insertion probe (plug-in type without cable) for soft media 	approx. 3 sec.	Flexible stainless steel (V4A) needle, 1.5 mm Ø, DIN-type flat-pin plug, rigid connection
GTT 1150 OK	-200 ... +1150°C	Immersion probe (also suitable for gases/air - use as surface probe limited) 	approx. 3 sec.	Thermowell, Inconel 1.5 mm Ø, electrically insulated , flexible, DIN-type flat-pin plug, rigid connection (other length or Ø p.r.t. p. 126)

Customized jacket thermo elements NiCr-Ni, low price standard lengths available from stock

(Delivery on short notice from stock or within 1 or 2 working days) - please do not hesitate to contact us !)

1. Jacket thermo elements NiCr-Ni (type K) complete with miniature flat-pin plug NST1200 (free from thermal e.m.f.)

Specification:

Jacket material: Inconel 600, flexible - other materials upon request

Insulation: highly compressed pure MgO

Thermo wires: NiCr-Ni, DIN IEC 584, welding insulated (volt-free)

Accuracy: optimum accuracy (Cl. 1) = $\pm 1.5^{\circ}\text{C}$ or $\pm 0,4\%$ of measuring value

(Almost double accuracy as compared to class 2. As a comparison with class 2: $\pm 2,5^{\circ}\text{C}$ or $\pm 0,75\%$ of meas. value)

Temperature application range: $-220 \dots +1150^{\circ}\text{C}$ (Probe tip and front part; wire outlet: max. 200°C)
(Accuracy class 1 applicable from $-40 \dots +1000^{\circ}\text{C}$)

Upon request:

Miniature flat-pin coupling free from thermal voltage. (Please order separately)

Type NKU 1200

Integral U-coupling (for installation in front panels)

Type NKU 1200 O

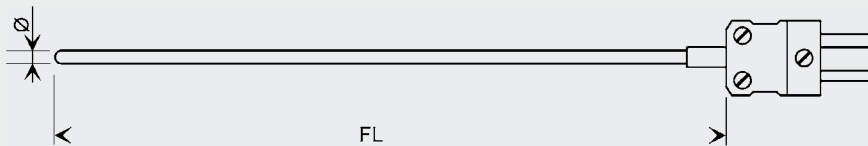

Advantages of the flat-pin plug free from thermal e.m.f.:

- Same material for contacts and thermo elements
- No incorrect temperature values due to different materials
- Polarity cannot be mixed up
- One plug size for \varnothing from 0,5 to 6,0 mm
- Any extension possible (extension cable VKA-1m or length per customers' requests)
- Sensor elements can be exchanged easily

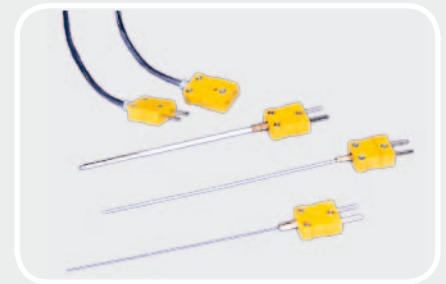

Type	\varnothing mm	FL mm $\pm 10\text{mm}$	Price	Type	\varnothing mm	FL mm $\pm 10\text{mm}$	Price
GTT05150	0,5	160		GTT30150	3,0	145	
GTT05250		260		GTT30250		245	
GTT05500		510		GTT30500		495	
GTT051000		1010		GTT301000		995	
GTT051500		1510		GTT301500		1495	
GTT10150	1,0	145		GTT60150	6,0	145	
GTT10250		245		GTT60250		245	
GTT10500		495		GTT60500		495	
GTT101000		995		GTT601000		995	
GTT101500		1495		GTT601500		1495	
GTT15150	1,5	145		Accessories:			
GTT15250		245		NKU1200	(coupling free from thermal e.m.f.)		
GTT15500		495		NKU1200O	(U-coupling free from thermal e.m.f.)		
GTT151000		995		NST1200	(plug free from thermal e.m.f.)		
GTT151500		1495		AGL1	(silicone compensation line)		
				VKA-1m	plug-in extension cable (each additional meter)		

All thermo elements accuracy class 1 (Almost double accuracy than class 2!)

2. Jacket thermo elements NiCr-Ni (type K) complete with cable sleeve and 1m silicone cable (compensation line), loose wire ends

Specification:

Jacket material: Inconel 600, flexible - other materials upon request and against upcharge

Insulation: highly compressed pure MgO

Thermo wires: NiCr-Ni, DIN IEC 584, welding insulated (volt-free)

Accuracy: optimum accuracy (Cl. 1) = $\pm 1.5^{\circ}\text{C}$ or $\pm 0,4\%$ of measuring value
(Almost double accuracy as compared to class 2. As a comparison with class 2: $\pm 2,5^{\circ}\text{C}$ or $\pm 0.75\%$ of meas. value)

Connecting cable: silicone compensation line, 1m long (max. 200°C), loose ends. (Longer line or other material against upcharge)

Temperature application range: $-220 \dots +1150^{\circ}\text{C}$ (Probe tip and front part; wire outlet: max. 200°C , for cable p.r.t. accessories)
(Accuracy class 1 applicable from $-40 \dots +1000^{\circ}\text{C}$)

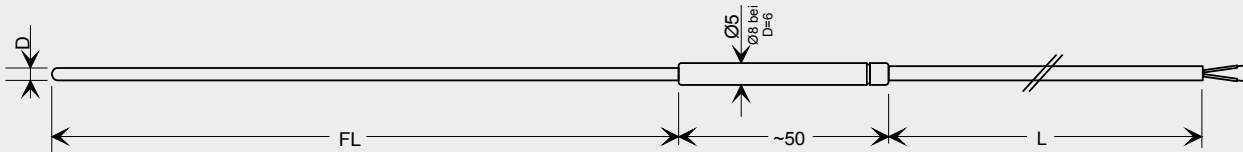

L = 1m, for other cable length or other accessories p.r.t. accessories

Advantages:

- Mechanically sound
- Can be subjected to high temperatures and pressures
- Resistant to aggressive atmospheres
- Minimum dimensions, therefore short response times
- Flexible (the smaller the diameter the smaller the bending radii)
- Optimum accuracy acc. to DIN IEC584 class 1
- Potential-free (thermoelement wires have no connection to the outer jacket)



Accessories: (against upcharge)

- Additional clamping screw-type connection for $\varnothing 1.5, 3.0$ and 6.0 (stainless steel). Design with st. steel clamping piece (for high temperatures) or with teflon clamping piece (up to $+250^{\circ}\text{C}$ - can be removed). Various thread diameters available (p.r.t. page 134-135)
- Extended or other cable (please specify upon order): silicone cable (up to 200°C) or glass silk cable (up to 400°C).
- Internal flat-pin plug (NST1200)

Type	\varnothing mm	FL mm ^{-20mm}	Price	Type	\varnothing mm	FL mm ^{-20mm}	Price
GTF101-5/05150	0,5	150		GTF101-5/30150	3,0	130	
GTF101-5/05250		250		GTF101-5/30250		230	
GTF101-5/05500		500		GTF101-5/30500		480	
GTF101-5/051000		1000		GTF101-5/301000		980	
GTF101-5/051500		1500		GTF101-5/301500		1480	
GTF101-5/10150	1,0	130		GTF101-5/60150	6,0	130	
GTF101-5/10250		230		GTF101-5/60250		230	
GTF101-5/10500		480		GTF101-5/60500		480	
GTF101-5/101000		980		GTF101-5/601000		980	
GTF101-5/101500		1480		GTF101-5/601500		1480	
GTF101-5/15150	1,5	130		Accessories:			
GTF101-5/15250		230		Clamping screw conn. $\varnothing 1.5, 3.0$ or 6.0			
GTF101-5/15500		480		Silicone cable (up to 200°C)			
GTF101-5/151000		980		Glass silk cable (up to 400°C)			
GTF101-5/151500		1480		Internal flat-pin plug (NST1200)			
				Other accessories see pages 126, 134 and 135.			

Accuracy class 1 for all thermo elements (almost double accuracy than class 2!)

Pt10Rh-Pt (Typ S) - measuring probes (class 1) for highest temperatures

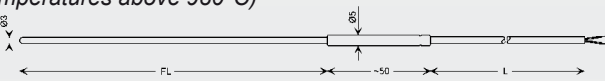

Ordering type Measuring range	Application / Dimensions (mm)	Response time T_{90}	further technical details
GTF 1500/300 +50 ... +1500°C	Probe for burning kilns or similar applications Avoid fast temperature changes. Heat up and cool down the probe slowly with kiln.		ceramic tube (type 610) (FL=300mm), stainless steel handle, silicone cable, DIN-type flat-pin plug type "S"
GTF 1500/500 +50 ... +1500°C			as above, however FL = 500mm
GBF 1550 +50 ... +1550°C	Bunsen burner probe Probe tip can be directly exposed to the flame.	approx. 2 sec.	stainless steel tube Ø8mm, with reduced ceramic tube Ø5.5mm, plastic handle, silicone cable, DIN-type flat-pin plug type "S"
GTF 103 HT-S +50 ... +1600°C	Probe for fixed installation in burning kilns and similar appl. Heat up and cool down the probe slowly with kiln.		sensor tube made of high-grade ceramic KER710, ALU-B sensor head <i>other length upon request</i>

NiCrSi-NiSi (Typ N) - meas. probes (class 1) low cost measuring of high temperatures (permanent up to 1300°C)

GTF101-N03250 -50 ... +1300°C (short-term peaks up to 1330°C)	Probe for permanent high temperatures <i>Mantle material: special steel with extraordinary resistivity against oxidation at high temperatures and excellent corrosion resistance in chlorine and ammoniacal environments (Protective layer emerges at temperatures above 980°C)</i>	approx. 5 sec.	stainless steel tube (FL=250mm), 1m silicone cable, loose cable ends upcharge for any cable length
GTF101-N03500			as above, however FL = 500mm
GTF101-N031000			as above, however FL = 1000mm

other probes (Typ N) please refer to pages 126 / 127

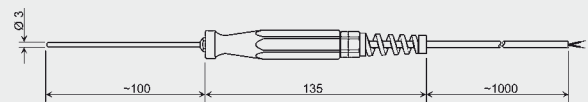
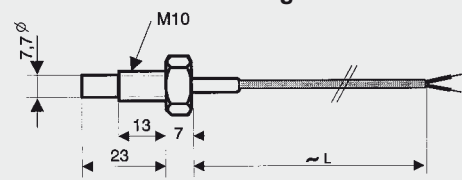
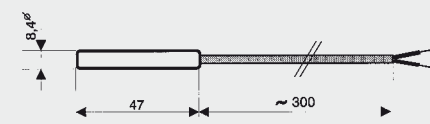
Silicium - meas. probes (sensor: KTY ...)

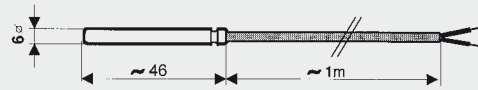
GTF 1400 B Sensor: KTY 81-210 -20 ... +110°C Replacement for KTY 11-6	Temperature probe for GPRT1400AN  OPTION: teflon covered probe tube (for use in salt water)	Sensor tube: made of V4A, with shrinkable sleeve at cable outlet Cable: approx. 1 m of highly flexible silicone cable with Ø 3.5 mm plug
GMF 11/180 Sensor: KTY 83-110 -50 ... +175°C	Screw-type sensor M10 	Sensor tube: V4A Handle: polyamide Cable: approx. 1m of highly flexible cable (2 x 0.25 ²)
GMF 15/81 Sensor: KTY 81-121 -50 ... +60°C	Immersion/touching/air sensor 	Sensor tube: V4A Cable: flexible silicone cable (2 x 0.25 ²), approx. 1m long
GMF 15/180 Sensor: KTY 83-110 -50 ... +60°C		
GMF 30/180 Sensor: KTY 83-110 -50 ... +60°C	 * Replacement for KTY 11-6 in the range -20 ... +60°C	Sensor tube: aluminium head, Ø 8.4 mm Cable: flexible silicone cable (2 x 0.25 ²), approx. 30 cm long upcharge per m of silicone cable
GMF 30/210 * Sensor: KTY 81-210 -50 ... +60°C		
GMF 30/180 V4A Sensor: KTY 83-110 -50 ... +175°C		Sensor tube: V4A-head, Ø5 mm Cable: approx. 1 m of highly flexible silicone cable.
GMF 30/81 V4A Sensor: KTY 81-121 -50 ... +150°C		Sensor tube: V4A-head, Ø 6 x 46 mm Cable: approx. 1 m of silicone cable.

Probs with Pt100, Pt1000 or KTY 84 upon request.

Accessories p.r.t. page 134-135



Industrial temperature probes (ATEX 100)

For all potentially explosive atmospheres of the equipment-group II with the protection (i) or (e)

GTF 101-Ex

-200°C ... +100°C (without neck tube)
-200°C ... +900°C (with neck tube)

Readily assembled voltage free temperature probe of stainless steel with connection cable. The sensor inset is not exchangeable. Mounting is done via separate clamping ring fittings GKV.

without neck tube, for temperatures ≤100°C



basic price

with neck tube, for temperatures >100°C



upcharges

Sensors: Pt100, Pt1000, mineral insulated element, 4-wire: meas. range: -200°C ... +100°C (600°C - with neck tube), DIN cl. B
type K or N, mineral insulated thermocouple: meas. range: -200°C ... +100°C (900°C - with neck tube), class 1

Probe length: up to 100mm (without upcharge)

upcharge per further starting 100mm

Neck tube length: without (without upcharge)

upcharge per starting 100mm

Probe diameter: 3mm, 4mm, 5mm, 6mm or 8mm

Cable: silicone cable, standard length 1m

upcharge per further starting m cable

Ambient temperature: -20...+60°C (protection type "e") resp. -20...+80°C (protection type "i")

Type of protection: "i" : intrinsic safety (without upcharge) "e": increased safety

Potentially explosive atmospheres: suitable for zone 1, zone 2, zone 21, zone 22

Clamping ring screw connection: available at M8x1, M10x1, G1/4" and G1/2" for diameter 3mm, 6mm or 8mm. Please refer to page 134

To determine exact order name ask for our type list. Download via homepage possible (Products -->Ex-Protection-->Temperature probes)

GTF 102-Ex

-200°C ... +100°C (without neck tube)
-200°C ... +900°C (with neck tube)

Readily assembled voltage free temperature probe of stainless steel with connection cable. The sensor inset is not exchangeable. Thread is welded or brazed to the probe.

without neck tube, for temp. ≤100°C



basic price

with neck tube, for temperatures >100°C

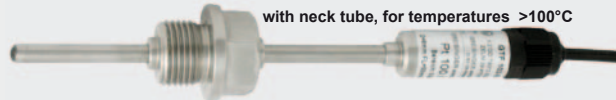

upcharges

Sensors: Pt100, Pt1000, mineral insulated element, 4-wire: meas. range: -200°C ... +100°C (600°C - with neck tube), DIN cl. B
type K or N, mineral insulated thermocouple: meas. range: -200°C ... +100°C (900°C - with neck tube), class 1

Probe length: up to 100mm (without upcharge)

upcharge per further starting 100mm

Neck tube length: without (without upcharge)

upcharge per starting 100mm

Probe diameter: 3mm, 4mm, 5mm, 6mm or 8mm

Thread: G1/2" (standard)

G1/8", G1/4", G3/8", G3/4", M8x1, M10x1

Cable: silicone cable, standard length 1m

upcharge per further starting m cable

Ambient temperature: -20...+60°C (protection type "e") resp. -20...+80°C (protection type "i")

Type of protection: "i" : intrinsic safety (without upcharge) "e": increased safety

Potentially explosive atmospheres: suitable for zone 0/1, zone 1, zone 2, zone 20/21, 21, zone 22

To determine exact order name ask for our type list. Download via homepage possible (Products -->Ex-Protection-->Temperature probes).

GTF 103-Ex

-200°C ... +100°C (without neck tube)
-200°C ... +900°C (with neck tube)

Readily assembled voltage free temperature probe of stainless steel connection head and clamping block. The sensor inset is exchangeable. Thread is welded or brazed to the probe. Mounting is done via clamping ring fitting or thread welded / brazed to the probe tube. The connection head is also suitable to carry a head transmitter.

without neck tube, for temp. ≤100°C

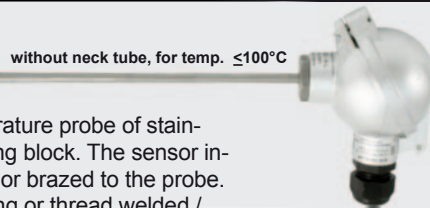

basic price

with neck tube, for temperatures >100°C

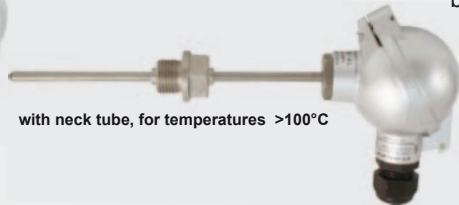

upcharges

Sensors: Pt100, Pt1000, mineral insulated element, 4-wire: meas. range: -200°C ... +100°C (600°C - with neck tube), DIN cl. B
type K or N, mineral insulated thermocouple: meas. range: -200°C ... +100°C (900°C - with neck tube), class 1

Probe length: up to 100mm (without upcharge)

upcharge per further starting 100mm

Neck tube length: without (without upcharge)

upcharge per starting 100mm

Probe diameter: 3mm (the sensor inset is **not** exchangeable)
4mm, 5mm, 6mm or 8mm (the sensor inset exchangeable)

Thread: G1/2" (standard) or without thread

G1/8", G1/4", G3/8", G3/4", M8x1, M10x1

Ambient temperature: -20...+60°C (protection type "e") resp. -20...+80°C (protection type "i")

Type of protection: "i" : intrinsic safety (without upcharge) "e": increased safety

Potentially explosive atmospheres: suitable for zone 0, zone 1, zone 2, zone 20, zone 21, zone 22

Transmitter: GITT 01-Ex (please refer to page 101), output signal 4-20mA, measuring range on customers demands
protection type "i" intrinsic safety. For suitable active Ex-barrier please refer to page 102

Clamping ring screw connection: available at M8x1, M10x1, G1/4" and G1/2" for diameter 3mm, 6mm or 8mm. Please refer to page 134

To determine exact order name ask for our type list. Download via homepage possible (Products -->Ex-Protection-->Temperature probes).

Industrial temperature probes

customized products can only be ordered written and can generally not be exchanged!

GTF 101

-200 ... +1150°C (depending on sensor)

pre-assembled according to customer specification

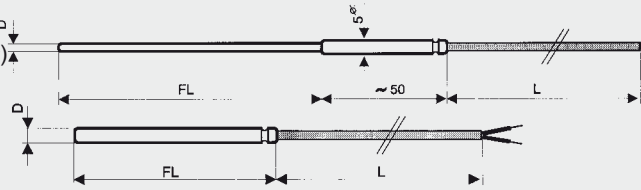

basic price
for Ø3mm, FL=100, L=1m of silicone cable
Final price can only be determined after receipt of customer specification!

Please contact us to find out which diases are available for our various sensors.

Available sensors: Pt100 (2-/ 3- or 4-wire), NiCr-Ni, Pt1000 and others - please contact us!

Measuring range: Pt100/Pt1000: -50 ... +400°C (others upon upcharge), NiCr-Ni: -200 ... +1150°C

Tube material: V4A

FL= please specify probe length upon order (in mm)

Basic price valid up to = 100mm, upcharge each started additional 100mm

D = Ø 0.5 mm to Ø 8.0 mm. - please specify Ø upon order (available Ø: 0.5, 1.0, 1.5, 2.0, 2.2, 3.0, 4.0, 5.0, 6.0, 6.7, 8.0)

At probe diameters below 4 mm an additional sleeve of Ø 5 mm and 50 mm length is mounted.

Basic price valid for D>3mm. Diases < 3mm upon request

L = desired cable length, cable screening (e.g. PVC, silicon, teflon, glass silk etc.) and wire quantity (e.g. 2-, 3- or 4-wire) to be specified on order. Basic price valid for silicone cable, 1m.

for upcharge p.r.t. page 135

Additional specification: a) temperature range

b) ambient temperature

c) plug or other cable connection

Please note: depending on tube diameter the sensor design may deviate from figure.

GTF 102

-200 ... +1150°C (depending on sensor)

pre-assembled according to customer specification

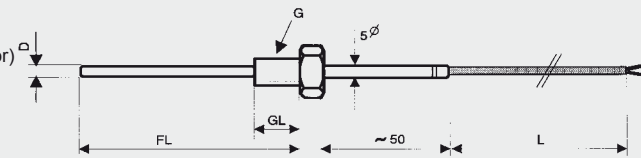

basic price

Final price can only be determined after receipt of customer specification!

Please contact us to find out which diases are available for our various sensors.

Available sensors: Pt100 (2-/ 3- or 4-wire), NiCr-Ni, Pt1000 and others - please contact us!

Measuring range: Pt100/Pt1000: -50 ... +400°C (others upon upcharge), NiCr-Ni: -200 ... +1150°C

Tube material: V4A

FL= please specify probe length upon order (in mm)

Basic price valid up to = 100mm, upcharge each started additional 100mm

D = Ø 0.5 mm to Ø 8.0 mm. - please specify Ø upon order (available Ø: 0.5, 1.0, 1.5, 2.0, 2.2, 3.0, 4.0, 5.0, 6.0, 6.7, 8.0)

Basic price valid for D>3mm. Diases < 3mm upon request

L = desired cable length, cable screening (e.g. PVC, silicon, teflon, glass silk etc.) and wire quantity (e.g. 2-, 3- or 4-wire) to be specified on order. Basic price valid for silicone cable, 1m.

for upcharge p.r.t. page 135

G = please specify thread desired: e.g. M5 or G½" etc. **Material:** stainless steel

(Available threads: M5, M6, M8, M10, M12, G1/4", G3/8", G1/2", G3/4", M10x1, M12x1.5, M14x1.5). Basic price valid for all threads

GL = specification only required if max. lengths must not be exceeded; unless this is the case glandings acc. to DIN910 are used; for smaller threads certain standard lengths are used. Basic price valid for all threads certain

Additional specification: temperature range, ambient temperature, plug or other cable connection

Ordering example:

GTF102, Pt100, -50...400°C, FL=100mm, D=3mm, KL=1m, teflon cable, 4-wire

GTF102, NiCr-Ni (type K), -50...1150°C, FL=300mm, D=3mm, KL=2m, silicone cable

GTF 200 Pt100

-50 ... +200°C, Pt100, 4-wire

Sensor: Pt100, DIN cl.B (±0,3°C at 0°C)



Sensor sleeve made of st. steel
Cable: silicone (4 x 0.14²), approx. 1m
suitable for 2-/ 3- or 4-wire probe

GTF 200 Pt100 WD

-20 ... +105°C, Pt100, 4-wire

tube enclosed water proof!

Sensor: Pt100, DIN cl.B (±0,3°C at 0°C)

Sensor sleeve made of st. steel
Cable: PVC (4 x 0.14²), approx. 1m
suitable for 2-/ 3- or 4-wire probe

GRO 200 Pt100

GRO 200 Pt1000

-50 ... +200°C, DIN cl.B, 4-wire

GRO 200 K

-50 ... +200°C, NiCr-Ni (type K)

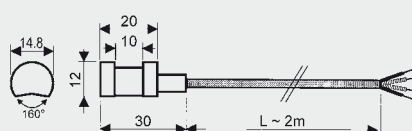

Sensor body made of aluminium
Cable: silicone, approx. 2m
Probe can be mounted with cable clamp or similar constructions to pipes
For faster heat exchange we suggest our heat-conductive paste **GWL10G**

Industrial temperature probes

customized products can only be ordered written and can generally not be exchanged!
(Del. time from stock or 1 to 2 working days)

GTF 103 (basic design)

GTF 103 OS (without sensor and terminal)

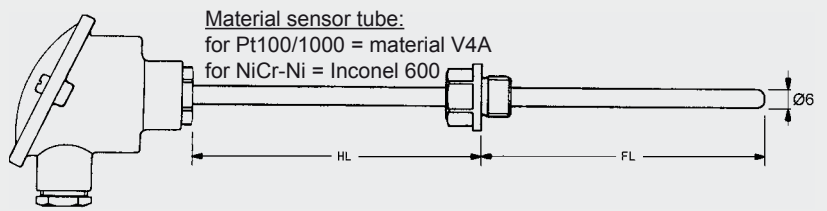
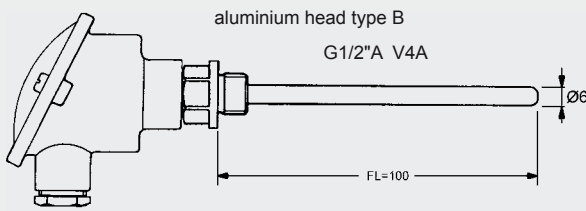

Sensor:

Pt100 / Pt1000 (2-, 3- or 4-wire)

- 50 ... + 400°C, DIN class B
- ±200°C, DIN class B
- 50 ... + 600°C, DIN cl. B, Jacket-Pt100 p.r.t. Probe Diameter

Double - Pt100 (2 x 2-wire) - others on request

- 50 ... + 400°C, DIN class B
- ±200°C, DIN class B
- Double jacket Pt100

NiCr-Ni (type K)

- 200 ... + 1150°C, class 1

Double - NiCr-Ni (type K)

- 200 ... + 1150°C, class 1

Sensor Head:

- DIN B head (Alu lacquered), max. 200°C
note: for higher temperatures order with neck tube
- plastic sensor head
- stainless steel sensor head
- small sensor head (design type DE) with PG9-cable glanding
- with exchangeable measuring insert

Thread:

*Note: other threads are not available for small series!
(For larger series on request)*

- without thread
for interchangeable sensor application in combination with immersion sleeve EST01 or with stainless steel clamping ring glanding for exact adjustment of sensor position.
- thread G $\frac{1}{2}$ " (V4A) standard
for fixed mounting or for interchangeable sensor in combination with immersion sleeve EST02.
- thread G $\frac{1}{4}$ ", G $\frac{3}{8}$ " (V4A)
- other thread

upcharges:

standard

Tube length: (Pt100/1000 and NiCr-Ni)

- Probe length "FL" up to 100mm
- Probe length per each started additional 100 mm
- Neck tube length "HL" each started 100 mm
recommended for higher temperatures, because sensor head (without transmitter) is suitable just up to 200°C or for bridging insulations.
- Insertion spike
- Teflon coat (100 mm, Ø 1,5 / 3 / 4 / 5 / 6)

upcharges:

standard

Probe diameter:

note: other diameters than stated below are not available!

Pt100 / Pt1000

- Ø 6 mm, not flexible
- Ø 3, 4, 5 or 8 mm, not flexible
- Ø reduced at the end (e.g. 8 to 3 mm)

standard

Jacket-Pt100

- Ø 6 mm, approx. 40 mm stiff, then flexible
- Ø 3 mm, approx. 30 mm stiff, then flexible

NiCr-Ni (type K), not potential-free

- Ø 6 mm, not flexible
- Ø 3 mm, not flexible

standard

NiCr-Ni (type K), jacket thermo element, potential-free

- Ø 6 mm, flexible
- Ø 1, 1.5 or 3 mm, flexible
- Ø 0.5 mm, flexible

Special design types:

... / **RT420** with transducer for Pt100,
Output signal 4-20mA, measuring ranges p.r.t. page 100
(to be stated on order!)

... / **T03 BU** with transducer for Pt100,
Output signal 0-10V, measuring ranges p.r.t. page 99
(to be stated on order!)

... / **GITT** with electrically isolated transducer
for Pt100/1000, NiCr-Ni, output signal 4-20mA, measuring range to be
stated on order! (p.r.t. page 101)

other design types upon request

upcharges:

Probe with elbow-type plug

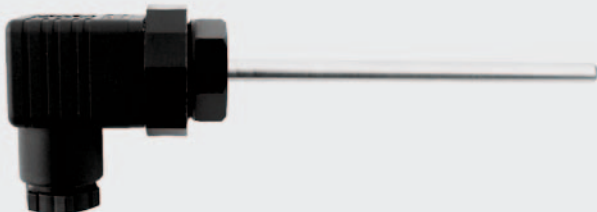

GTF 104 ...

Please state probe length (FL) at order

- protection tube made of stainless steel
- different length available
- applicable for
 - refrigeration engineering
 - heating installations / furnace construction
 - apparatus construction

GKV

Clamping ring screw connection (p.r.t.p. 134)

Specifications:

Sensor:

Pt100: 4-wire, sheath element
Measuring range: -50 ... +600 °C

NiCr-Ni: type K, class 1, sheath element
Measuring range: -50 ... +1150 °C

Pt1000:

Diameter: D = 6 mm
Probe length: FL = 50 / 100 / 200 / 400 mm
Electric connection: type plug acc. to DIN EN 175301-803

GTF 104 Pt100

FL	50 mm	100 mm	200 mm	400 mm
Price				

GTF 104 K (NiCr-Ni, type K)

FL	50 mm	100 mm	200 mm	400 mm
Price				

water proof, hermetically sealed temperature probes for use in aggressive environments and tight places

Advantages:

- highly resilient to chemicals and oils
- sealed against moisture and corrosion
- easily cleaned and sterilised
- food safe
- small size provides a fast response
- also available in custom lengths
- optionally with mechanical protection (V4A-sleeve) and with thread or clamping ring screw connection available.

Design type Pt100

TF101P-1m Pt100, cable length 1 m

TF101P-2m Pt100, cable length 2 m

TF101P-3m Pt100, cable length 3 m

- flexible sealed PFA Pt100 sensor
- 4-wire-connection (4 x 0.14 mm², nickel-plated copper)
- nominal diameter: 2.1 mm
- accuracy according to DIN class A
- temperature range: -60 ... +250 °C
- also available with Pt1000

Design type NiCr-Ni (type K)

TF101K-1m NiCr-Ni, cable length 1 m

TF101K-2m NiCr-Ni, cable length 2 m

TF101K-3m NiCr-Ni, cable length 3 m

- These PFA insulated thermocouple wire sensors are hermetically seal-welded at the sensor tip to provide continuous PFA protection over the measurement junction.
- stranded NiCr-Ni-thermocouple wire (0.14 mm²)
- nominal cross section: 1.6 mm x 2.5 mm
- rated to +250 °C
- IP68 seal-welded tip
- electrically-insulated junction
- also available with thermocouples type J, T and E

Option:

- Water proof probe with robust V4A protective tube
Ø 3 mm, FL = 50 mm

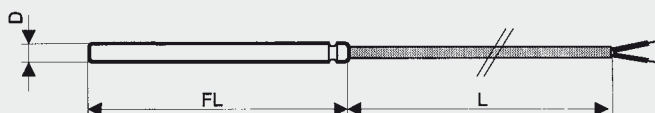

Average temperature probe

MWF 100 Pt100 (2-, 3- or 4-wire)

General description

The bendable average temperature probes are measuring the average temperature over the whole length of the probe and not like the standard probes only on the sensor tip.

There are short probe length of a little centimetres as well as length of any metres (e.g. 30 m) feasible.

Application area: Measuring of the average value at long heating or cooling elements, air ducts etc.

Tell us your requested application. We will offer you the an individual sensor construction !

Self-adhesive temperature probes

with moulded silicone design for surface measurement on curved and flat surfaces

GOF 112 Pt	Pt100, 35 x 12 mm, cable length 2m, white
GOF 112 K	NiCr-Ni, 35 x 12 mm, cable length 2m, green
GOF 115 Pt	Pt100, 15 x 50 mm, cable length 2m, white
GOF 115 K	NiCr-Ni, 15 x 50 mm, cable length 2m, green

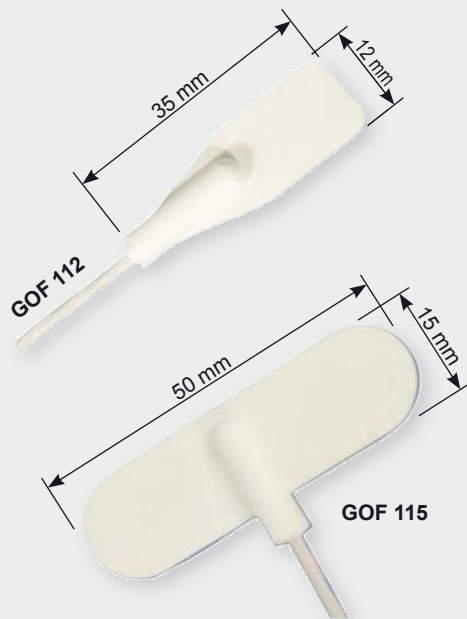

Advantages:

- sensor have adhesive back for easy mounting
- ultra-slim silicone rubber for maximum flexibility
- resistant to a variety of chemicals and oils
- PFA-insulated connection cable, 2 m long (other length up on request)
- 2 designs for flat (GOF 112) or curved (GOF 115) surfaces available

Design type Pt100

- precision Pt100-probe, DIN class A, 4-wire connection
- temperature range: -50 ... +200 °C
- also available with Pt1000

Design type NiCr-Ni (type K)

The integral thermocouple sensor is bonded onto the inner surface of the self adhesive aluminum foil strip, which is provided for fast response time

- stranded NiCr-Ni-thermocouple wire (0.14 mm²)
- temperature range: -50 ... +200 °C
- also available with thermocouples type J, T and E

"Cement-On" thermocouples

General description

The series GOF 120 are a model line of Cement-On, fast response thermocouples for fast surface temperature measurement. The model line have 3 different styles. (Please order the high temperature cement separately)

The **design styles 1 and 2** are made from 0.013 mm thermocouple alloy foil by a special process where the butt welded thermocouple junction is 0.013 mm in thickness. The thermocouples are fabricated from class 1!

These styles are flat, extremely low inertia construction and are ideal means of measuring the temperature of both flat and curved metals, plastic and ceramic surfaces where very fast response is desired.

The **design style 3** is an economy version constructed from 0.25 mm diameter bead welded standard limit of error thermocouple wire. It should be used where extremely fast response time is not essential.

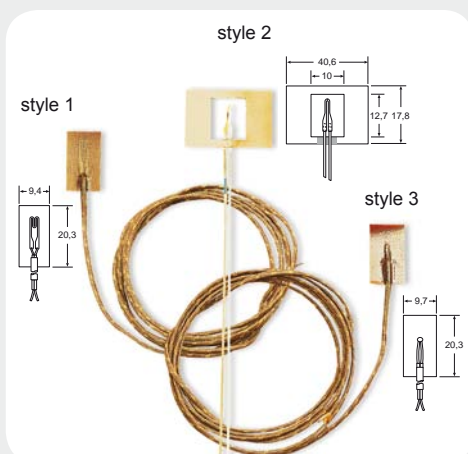

GOF 120 - K1 NiCr-Ni, cable length 90 cm, max. 260°C (short-time: 370°C)

GOF 120 - K2 NiCr-Ni, cable length 15 cm, max. 540°C (short-time: 650°C)

GOF 120 - K3 NiCr-Ni, cable length 90 cm, max. 260°C (short-time: 370°C)

OB-700 high temperature chemical set cement, 235 ml (max. 871°C)

Highlights:

- ultra fast response time
(style 1: t_{63} = approx. 20 ms, style 2: approx. 5 ms, style 3: approx. 300 ms)
- very low thermal inertia
- also available with thermocouples type J (only design 3), T and E
- style 1 and 3 optionally available with other lengths

Please note: cannot be used with high temperature cement (will break down insulation)

Industrial probes for food-, beverage- and pharma industry

In case of interest, please ask for the **GHM** Industrial probes brochure.



GTL ...

Probes according to customer specification

Measuring range:	-40 ... +200°C (depending on probe construction)
Sensor:	Pt 100
Process connection:	M12 / G1/2" / without thread
Probe head:	probe head Ø 59 mm probe head Ø 18 mm Long (with transmitter) probe head Ø 18 mm Short (without transmitter)
Material:	sensor head: V2A, protection tube and peak: V4A
Probe length:	according to customer specification (in mm)
Diameter:	Ø 6 mm without contraction Ø 4 mm without contraction Ø 6 mm with offset probe peak Ø 3 mm
Response Time:	Peak Ø 6 mm: $T_{90} \leq 8,0$ s Peak Ø 4 mm: $T_{90} \leq 6,5$ s Peak Ø 3 mm: $T_{90} \leq 1,5$ s
Protection class:	IP69K / IP67
Options:	Neck tube Electr. connection: fixed cable (PG) or M12-plug Integrated transmitter Higher accuracy (1/3 DIN Kl. B or 1/10 DIN Kl. B) Display

Accessories

1. Clamping ring screw connection GKV... st. steel (for all probes without thread)

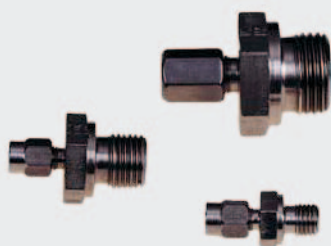

Type:	Outside thread	Clamp. ring-Ø (sensor tube-Ø)	Clamping ring	Price		
GKV1	M8 x 1	1,5 mm	Teflon			
GKV2			st. steel			
GKV3		3,0 mm	Teflon			
GKV4			st. steel			
GKV5	G1/4"	1,5 mm	Teflon			
GKV6			st. steel			
GKV7		3,0 mm	Teflon			
GKV8			st. steel			
GKV11		6,0 mm	Teflon			
GKV12			st. steel			
GKV9		G1/2"	6,0 mm		Teflon	
GKV10					st. steel	
GKV13	8,0 mm		Teflon			
GKV14			st. steel			
GKV15	14,0 mm		Teflon			
GKV16	M10x1	6,0 mm	st. steel			

2. Flat-pin connections, free from thermal e.m.f. (for type K, N and S)

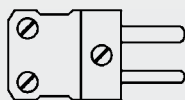

NST 1200
NST 1300
NST 1700

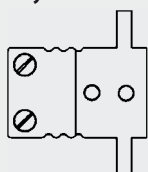

NKU 1200 O
U-coupling for installation in
front panels

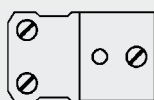

NKU 1200
NKU 1700

NST 1200 "K"
NKU 1200 "K"
NKU 1200 O "K" (max. 120°C)
NST 1300 "N"
NST 1700 "S"
NKU 1700 "S"

For higher temperatures use ceramic plug and coupling - price upon request.

3. Immersion sleeve of stainless steel

3.1. Immersion sleeve EST01 for all probes without thread .

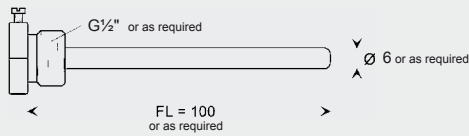

standard: G1/2", FL=100mm, outside-Ø = 6mm
for probes with 5mm Ø
customized lengths, diameters or threads are possible against upcharge - to be stated on order!

3.2. Immersion sleeve EST02 for all probes with a G1/2"-thread.

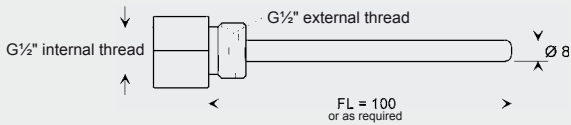

standard: G1/2" (internal/external), FL=100mm, outside-Ø = 8mm for probes with 6mm Ø
customized lengths, diameters or threads are possible against upcharge - to be stated on order!

For faster heat exchange we suggest:

GWL10G heat-conductive paste 10g

4. Cables and lines

4.1. Silicone cable (max. 200°C) with teflon screened wires

S2P: silicone cable, 2-pole (2 x 0.25 mm²), highly flexible

S4P: silicone cable, 4-pole, 4 x 0.14² cross section (insulation 2 x blue, 2 x white)
(can also used as 3-wire)

4.2. Glass silk insulated cable (max. 400°C) with stainless steel braiding

G2P: glass silk insulated cable, 2-pole (2 x 0.22 mm²)

G3P: glass silk insulated cable, 3-pole (3 x 0.22 mm²)

G4P: glass silk insulated cable, 4-pole (4 x 0.22 mm²)

4.3. Teflon insulated cable (max. 250°C) with individual teflon insulated wires

T2P: teflon insulated cable, 2-pole (2 x 0.14 mm²)

T3P: teflon insulated cable, 3-pole (3 x 0.14 mm²), with additional cable screen

T4P: teflon insulated cable, 4-pole (4 x 0.14 mm²), with additional cable screen

4.4. PVC-lines (max. 70°C)

P2P: PVC cable, 2-pole (2 x 0.14 mm²)

P3P: PVC cable, 3-pole (3 x 0.14 mm²)

P4P: PVC cable, 4-pole (4 x 0.14 mm²)

4.5. Extension cable for NiCr-Ni (Type K)

VKA 1m: 1 m Silicon-Compensation lines with DIN plug and DIN coupler

(upcharge for additional meter)

4.6. Compensation lines for NiCr-Ni (type K), 2-wire

AGL1: Silicone cable (2 x 0.22 mm²) (max. 200°C)

AGL3: Thermo wire (can also be used as thermo couple) glass silk (2 x 0.5 mm²) (max. 400°C)

AGL4: Teflon screened twisted thermo wire, wire-Ø 0,2 mm (max. 250°C)

AGL5: Thermo wire, with glass silk braiding, wire-Ø 0,2 mm (max. 400°C)

AGL6: Teflon cable, screened - can also be used as thermo couple (2 x 0.22 mm²) (max. 250°C)

4.7. Compensation lines for Pt10RH-Pt (Type S), 2-wire

AGL S2: Silicone cable (max. 200°C)

4.8. Compensation lines for NiCrSi-NiSi (Type N), 2-wire

AGL N2: Silicone cable (max. 200°C)

5. Metal flange (for GTF 1500/... and GTF 103HT-S)

GMFL: acc. DIN 43734, adjustable, to clamp to 15mm stainless steel pipes, sliding

6. Sensor elements (Pt100/1000, NTC's, PTC's) NiCr-Ni p.r.t. pages 126-127

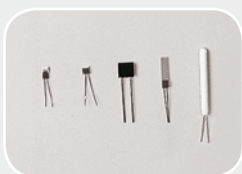

Type:	Description, dimensions	meas. range	tolerance
Pt100/1	Ceramic lamina, 2 x 2.3 x 0.6 mm	-50 ... +500°C	B
Pt100/2	Ceramic lamina, 2 x 2.3 x 0.6 mm	-50 ... +500°C	1/3 DIN
Pt100/3	Ceramic lamina, 2 x 5 x 0.9 mm	-196 ... +500°C	B
Pt100/4	Wound design, Ø2 x 20 mm	-200 ... +600°C	B
Pt100/5	TO92-housing	-50 ... +150°C	B
Pt100/6	Ceramic lamina, 1 x 3 x 0.6 mm	-50 ... +500°C	B
Pt1000/1	Ceramic lamina, 2 x 4 x 0.9 mm	-50 ... +400°C	B
Pt1000/2	TO92-housing	-50 ... +150°C	B
Pt1000/3	Ceramic lamina, 1 x 3 x 0.6 mm	-50 ... +500°C	B
KTY 81-210	Replacement for KTY 11-6	-20 ... +110°C	
KTY 81-121	1kOhm (25°C), TO92-housing	-50 ... +150°C	
KTY 83-110	1kOhm (25°C), DO-34-housing	-50 ... +175°C	
KTY 84-130	1kOhm (100°C), DO-34-housing	-40 ... +300°C	

Other sensors upon request

Alarm and Protection Devices

	Application							Description	Page
	Universal Application	Level controller	Water leak detector	Electrodes incl.	Alarm buzzer	Switching output	Water supply is switched of		

ALARM DEVICE

MINAL 182	✓		✓		✓			Miniature alarm device (Battery operation)	137
MINAL 282 BN	✓		✓		✓			Miniature alarm device (Battery / mains operation)	137

ALARM AND PROTECTION DEVICE (Home- and Handicraft)

ALSCHU 480	✓		✓		✓	✓		Alarm and protection device (switching output via SCHUKO socket)	137
ALSCHU 480 P	✓		✓		✓	✓		Alarm and protection device (potential-free switching output and SCHUKO socket is current-carrying)	137
ALSCHU 485		✓		✓	✓	✓		Electrode control device incl. two 2-pin electrodes	137
ALSCHU 485 OE		✓			✓	✓		Electrode control device with connection for two 2-pin electrodes	137
ALSCHU 485 OE / 3P		✓			✓	✓		Electrode control device with connection for two 3-pin electrodes	137
GEWAS 181 A			✓	✓	✓	✓	✓	Water leak detector with 1/2" brass solenoid valve with 3/4" connections for switch-off	138
GEWAS 183 A			✓	✓	✓	✓	✓	Water leak detector without solenoid valve, with switch-off	138
GEWAS 181 A - 1/2"			✓	✓	✓	✓	✓	Water leak detector with 1/2" brass solenoid valve and switch-off	138
GEWAS 181 A - 3/4"			✓	✓	✓	✓	✓	Water leak detector with 3/4" brass solenoid valve and switch-off	138
GEWAS 181 A - 1"			✓	✓	✓	✓	✓	Water leak detector with 1" brass solenoid valve and switch-off	138
GEWAS 191 N			✓	✓	✓		✓	Water leak detector with 3/4" solenoid valve	139
GEWAS 191 AN			✓	✓	✓	✓	✓	Water leak detector with 3/4" solenoid valve and switch-off	139

ALARM AND PROTECTION DEVICE (Industry)

GEWAS 200	✓					✓		Alarm and protection device for panel mounting	139
GEWAS 300 SG	✓					✓		Alarm and protection device for panel mounting	141
GEWAS 300 FG	✓				✓	✓		Alarm and protection device in field housing	141
ALSCHU 300 SG	✓	✓				✓		Alarm and protection device for panel mounting	137
ALSCHU 300 FG	✓	✓				✓		Alarm and protection device in field housing	137



Miniature alarm device for universal application battery or mains operation



MINIATURE ALARM DEVICE for universal application

MINAL 182

Battery operation

MINAL 282 BN

Battery/mains operation

Devices without sensors

Application: extra loud alarm (more than 100 dB at 1 m distance), hence suitable for decentralised use (eg in basement etc.). After connection of various sensors device can be used as water detector, burglar alarm, fire alarm (overheating), heating failure detector, level detector, rain detector etc..

Advantages: mobile, no power consumption unless alarm sounded; connection of any number of sensors, separately or simultaneously; loud alarm that cannot be missed.

Specification:

Device: rocker switch for tightening and alarm extinguishing, audible piezo-alarm, power consumption in case of alarm approx. 20 mA. Permanent alarm can be sounded for at least approx. 10 h.

ABS case 100 x 60 x 29 mm (H x W x D)

Operating voltage: 9 to 12 VDC, battery 9 V type IEC 6F22 included, for MINAL 282 BN additional socket for plug-in of external power supply GNG09 for permanent operation.

MINAL 182 only suitable for battery operation.

Sensors: jack for connection of any sensor type (see special accessories).

Weight: approx. 105 g (incl. battery - without sensor)

Accessories:

GNG 09 - 3.5KS power supply

GWF-1S plug-in water sensor, 2m

GWF-1S/5m plug-in water sensor, 5m

GWF-1S/10m plug-in water sensor, 10m

GAZ-1 branch adapter (required for each additional water sensor)

VEKA 2 extension cable 2m

VEKA 5 extension cable 5m

VEKA 10 extension cable 10m

Electrode controller with two signal inputs in 2 different mounting forms



ALSCHU 300 FG

Electrode controller in **field frame** for wall mounting – device without sensor

Available from the 2nd quarter of 2012

ALSCHU 300 SP

Electrode controller in **snap-on housing** for DIN rail mounting – device without sensor

Available from the 2nd quarter of 2012

Applications:

Automatic control of drainage pumps and wastewater lifting plants, overflow and low liquid level control, automatic filling and draining of tanks, level control of liquid reservoirs, aquariums, storage tanks, etc.

The ALSCHU 300 .. is especially suitable for detection of conducting media (water, etc.). It is less applicable for badly or non conducting media (oils or fatty liquids), conducting foaming liquids or media causing electrically isolating deposits on the electrodes.

Description:

The measuring method for level detection is based on the conductive principle, i.e. the electrical conductivity of the media is monitored. If the switching amplifier detects a value below the set conductivity the state "media detected" is output, otherwise "no media". Depending on number and design of the connected level sensors the device can be used for level detection (min-/max- detection) or as 2-point controller.

Specifications:

Power supply: 18 V ... 250 V AC/DC
wide-range power supply

Power consumption: < 2 VA

2 signal inputs:

Triggering level: < 100 kΩ

Response time: 2 s

1 Relay output:

Contact: change-over contact,
potential-free
Switching voltage: ≤ 250 V AC
Switching current: ≤ 5 A (ohmic load)

Protection class:

ALSCHU 300 SP: IP20

ALSCHU 300 FG: IP65

Electric connection:

ALSCHU 300 SP: connection via screw-type terminal
ALSCHU 300 FG: connection via 3 PG cable glands and screw terminals

Working temperature: -20 ... +60 °C

Storage temperature: -40 ... +80 °C

Condensation: not allowed

Housing:

ALSCHU 300 SP: snap-on housing for DIN rail mounting
22.5 x 75 x 110 mm
(W x H x D)
ALSCHU 300 FG: field frame
100 x 100 x 60 mm
(W x H x D) without PG cable glands

Functions / displays:

Red / green LED:
display for switching state of relay, switching state of sensors, status (supply) of device

Accessories:

GNS-3P (p.r.t. page 117)

3-pole level probe

GNS-3P-S.. (p.r.t. p. 117)

3-pole level probe with coating

GSS-1 level sensor, 2m cable (floating switch) for electrically non-conducting media

GNS-1 level sensor, 2-pole (stainless steel electrode)

GSAS-1 magnetic contact, plug-in and self-adhesive



Protection device for universal application with switching output for any purpose Available as plug-in



ALARM PROTECTION DEVICE with or without alarm transmitter and relay switching output (changeover contact)

ALSCHU 480

plug-in for 230V~ (with grounding contact adaptor plug)

ALSCHU 480 P

as above, but with volt-free switching output

Description:

The ALSCHU 480(P) is a versatile alarm and protection device. Its universal input (3.5mm jack bush) allows a lot of different external sensors to be connected. That includes sensors with a switching threshold <100kOhm like water sensors, float switches, level switches, magnetic contacts, safety shut-off mat etc. In case of an alarm the internal buzzer sounds and a connected device (i.e. pump, machine) is switched on or off via the Schuko adaptor plug (ALSCHU 480). The desired switching function can be set via selector switch I / II. ALSCHU 480P switches on/off external devices via a potential-free 2-pole switching output. The Schuko socket of ALSCHU 480P is always current-carrying.

Specification:

Power supply:	220/240V 50/60Hz
Power consumption:	approx. 1 VA
Sensor input:	3.5mm jack bush
Switching threshold:	input resistance <100kOhm
Switching output:	
480:	via isolated ground receptacle (Schuko)
480P:	potential-free normally open/closed contact via 2-pole cable, brought out 0.5m
Switching function:	
I:	switching out put current-carrying in alarm condition
II:	switching output currentless in alarm condition
Switching power:	
480, 480P:	250VAC, 10A (ohmic load), max. 2400VA
480P:	120VDC, 2 A (ohmic load), max. 240W

Controlling device:

dimensions: 112 x 71 x 48mm (L x W x H),
Working conditions: -20...50°C / 0...80% RH

LED for operation display, device-on/off, selector switch I / II for switching function

Accessories:

GWF-1S plug-in water sensor, 2m
GSAS-1S plug-in, self-adhesive magnetic contact

Plug-in level controller no moving parts at all



ELECTRODE CONTROL DEVICE for filling or emptying

ALSCHU 485

ALSCHU 485 OE

(as above, but without electrodes - connect. for two 2-pin. electrodes)

ALSCHU 485 OE / 3P

(as above, but without electrodes - connection for 3-pin electrode)

We manufacture electrodes of any diameter and length according to your specifications

Application:

automatic control of drain pumps and sewage removal plants, overflow and dry running protection, automatic filling and emptying of containers, basins, tanks, control of liquid level in storage tanks, aquariums, etc.

Advantages:

no installation costs, only plug-in connections, ready for use within seconds, trouble-free operation as no moveable float switches are used, any electrode distance, can be set by customer up to 2 m etc. etc..

Specification:

Control device:	housing 112 x 71 x 48 mm. Flashing LED indicating control state. Selector switch for emptying or filling. Plug-in socket for electrodes.
Power supply:	control device 230 V 50 Hz approx. 1 VA, automatic by connecting grounded adaptor plug.
Control output:	via grounded adaptor plug with earthing and socket outlet with earthing, electrode control. Direct switching capacity approx. 1200 VA at 230 V 50 Hz (approx. 5 A ohmic load). Extra high protective capacity by external triggering of a contactor or semiconductor relay.
Electrodes:	standard design: plug-in, stainless steel pins, plastic body and 2 m of PVC cable (any lengths against upcharge)

Please note: for media leaving residues (such as salt water, sewage etc.) we recommend a 3-pin electrode.

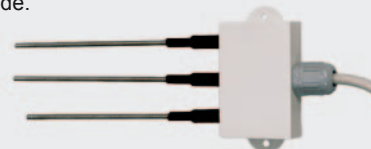

Accessories:

GNS-3P level probe 3-pin
standard length: 15 cm,
switching distance: 1cm, 2m cable
further information p.r.t. page 117

No more water damage !



GEWAS 181 A

leak-water detector with 1/2" brass solenoid valve with 3/4" connections for hand installation, water sensor, alarm buzzer and switch-off of connected units 16A, 230V~

GEWAS 183 A

leak water detector without solenoid valve, with water sensor, alarm buzzer and switchoff of connected devices 16A, 230V~

GEWAS 181 A - 1/2"

leak water detector with 1/2" brass solenoid valve (flow quantity: approx. 20 l/Min, installation length approx. 55mm) for installation in the line, water sensor, alarm buzzer and switch-off of connected devices 16A, 230V~. Device is capable to drive more valves.

Application:

Any devices or machines with water connection. For direct mounting of solenoid valve in pipelines.

Electric specification:

Solenoid:

100 V DC, approx. 2 W. Full load of approx. 8 watt available when start button is pressed at approx. 200 V DC. Hence, valve operable in permanent mode; due to energy-saving circuit valve will not run hot even without cooling agent. Valve permanently fixed to control device (approx. 1 m of connecting cable). Valve body can be removed from coil after loosening of one nut.

Water sensor:

Highly sensitive, plug-in water sensor, 2 m of cable, alarm triggered as of 1/2 mm water film. Simultaneous plug in of several water sensors via socket-outlet adaptor GAZ1. Plug-in extension cable (2 m, 5 m or 10 m long) available.

Alarm triggering:

Solenoid closing in case of alarm, buzzer sounding and machine connected will be turned off by means of a single-pole one-way switch.

Control device:

112 x 71 x 48 mm (H x W x D) with suspension hook. Operating lamps, double-pole switch, start button, alarm buzzer, approx. 1 m of connecting cable with earthing pin plug and socket. Socket (16 A 230 V~) is alarm triggered, i.e. the device plugged-in will be disconnected in case of alarm.

Power consumption:

Approx. 3 W only due to energy-saving circuit of solenoid valve.

GEWAS 181 A - 3/4"

leak water detector with 3/4" brass solenoid valve (flow quantity: approx. 91.5 l/Min, installation length approx. 80mm) for installation in the line, water sensor, alarm buzzer and switch-off of connected devices 16A, 230V~

GEWAS 181 A - 1"

leak water detector with 1" brass solenoid valve (flow quantity: approx. 141.5 l/Min, installation length approx. 95mm) for installation in the line, water sensor, alarm buzzer and switch-off of connected devices 16A, 230V~

Specification:

Solenoid valve:

Brass solenoid valve, energy-saving circuitry for hand installation (1/2" with 3/4" glanding - suitable for any 1/2" tap or 1/2" tube) or with 1/2", 3/4" or 1" internal thread on both sides for line installation. De-energised when closed, for pressure loads from 0.5 to 10 bar. Servo-controlled, i.e. free water outlet has to be provided resp. infeed pressure has to exceed outfeed pressure by 0.5 bar (solenoid not suitable for closed circuits such as heating systems).

Spare or additional solenoid valves:

- GMV-1/2" L** spare solenoid valve 1/2" for direct cable connection, approx. 1m cable, loose ends
- GMV-1/2" H** spare solenoid valve 1/2" manual mounting, approx. 1m cable, loose ends
- GMV-3/4"** spare solenoid valve 3/4" for direct cable connection, approx. 1m cable, loose ends
- GMV-1"** spare solenoid valve 1" for direct cable connection, approx. 1m cable, loose ends
- GMV-1/2" EZL** add. solenoid valve 1/2" for direct cable connection, with power saving connector, approx. 2W, for direct connection to 230VAC, suitable for GEWAS 183A or mains operation
- GMV-1/2" EZH** like before, but 3/4" valve for manual mounting
- GMV-3/4" EZ** like before, but 3/4" valve for direct cable connection
- GMV-1" EZ** like before, but 1" valve for direct cable connection

Accessories:

Plug-in water sensor, socket outlet adaptor, extension cable p.r.t. GEWAS 191

No more water damage !

24-hour supervision of your washing machine and/or dish washer or any other devices using water.



WATER LEAK DETECTOR WITH SOLENOID VALVE

GEWAS 191 N

cpl. and ready for use incl. controller, water probe, solenoid, signal buzzer

GEWAS 191 AN

cpl. as above but equipped with switch-off mechanism for supervised device in case of alarm (up to 16A, 220 V 50 Hz)

Application:

washing machine, dish washer, surgeries (eg dentists' surgeries, water-cooled devices etc.), hospitals, industry, research, laboratories, any other devices and machines with water connection (eg. hot drinks dispensers, cooling devices etc.)

Installation:

easy to install - even for unskilled persons - in two minutes without any additional parts or tools being required.

Solenoid valve:

glass-fibre reinforced polyamide (also used for washing machines). Extra low voltage for safety 12 V DC. Screw connections 3/4" for direct mounting to water tap or any other standard washing machine or dish washer connecting tube 1/2 " with 3/4" wing/union nut at valve outlet. Valve closes automatically in case of power failure. (Min. pressure difference between inlet and outlet: feed pressure min. 0.5 bar over discharge pressure)

Water sensor:

highly sensitive plug-in water probe, 2m cable. Alarm triggered as of 1/2 mm water film. Several water probes can be plugged-in and used simultaneously by means of socket outlet adaptor GAZ 1. 2 m, 5 m or 10 m plug-in extension cable available.

Alarm triggering:

in case of an alarm the valve closes, the signal buzzer is sounding and the device connected is switched off (only for GEWAS 191 AN - single pole one-way switch)

Device housing with electronics:

enclosed case (not suitable for use in humid environment), electronics, signal buzzer, plug connections for valve and water sensor. Housing with earthing pin plug connection and socket outlet with earthing contact. Looping-in socket outlet with earthing contact used for GEWAS 191 A; alarm controlled socket outlet with earthing contact used for GEWAS 191 AN, i.e. up to 16 A (ohmic load) and 220 V 50 Hz will be switched off in case of alarm.

Power consumption: approx. 3 W only using energy-saving circuitry.

Accessories and spare parts:

GMV191 spare solenoid

GWF-1S plug-in water sensor, 2m

GWF-1S/5m plug-in water sensor, 5m

GWF-1S/10m plug-in water sensor, 10m

GAZ-1 branch adaptor (required for each additional water sensor)

VEKA 2 extension cable 2m

VEKA 5 extension cable 5m

VEKA 10 extension cable 10m

Protection device for universal application with switching output for any purpose panel mounted device



GEWAS 200

Panel-mounted alarm protection device with volt-free relay output (snap-on mounting for top hat rail in special snap-on housing) Without Sensor

The GEWAS 200 is a versatile DIN rail alarm and protection device. Its universal input (screw terminals) allows a lot of different external sensors to be connected. That includes sensors with a switching threshold <100kOhm like water sensors, float switches, level switches, magnetic contacts, etc. A connected device (i.e. pump, machine) is switched on or off via potential-free change-over contact in case of an alarm. The alarm is reset by the use of an internal / external reset button.

Specification:

Power supply: 220/240V 50/60Hz

Power consumption: approx. 3 VA

Sensor input: 2-pole screw terminal

Switching threshold: input resistance <100kOhm

Switching output: potential-free change-over contact

Switching power: 250VAC, 10A (ohmic load), max 2400VA

150VDC, 2A (ohmic load), max 240W

Controlling device: dimensions: 49 x 96 x 59mm (L x W x H)

LED (green) for operation display

LED (red) for alarm condition

Mounting: universal foot base for all common DIN EN rails

Working conditions: -20...50°C and 0...80% RH

Options:

- **KL:** Screw terminal (2-pole)
to connect an external reset button

- **AL:** Automatic alarm reset

Accessories and spare parts:

GWF-1 water sensor without plug, 2m

GSS-1 level probe (plug-in float switch)

for electrically non-conductive media (normally open/normally closed function can be selected by customer)

GNS-1 plug-in level probe 2-pin (stainless steel electrodes)

GSAS-1 plug-in, self-adhesive, magnetic contact

Wasserwächter mit einem Signaleingang und einem Relaisausgang in 2 Bauformen



GEWAS 300 FG Water monitor in **field frame** for wall mounting – device without sensor
Available from the 2nd quarter of 2012

GEWAS 300 SP Water monitor in **snap-on housing** for DIN rail mounting – device without sensor
Available from the 2nd quarter of 2012

Applications:

Versatile alarm and protection device for DIN rail or surface mounting with universal input (screw-type terminals) for several external sensors. Sensors with switching threshold <100 kOhm can be connected (e.g. water probes, floating switches, level probes, magnetic contacts, etc.). In case of an alarm the connected device (e.g. pump, machine) is switched off by a change-over contact. The GEWAS 300 FG additionally provides an alarm. The internal or an external push-button resets the alarm state.

The GEWAS 300 .. is especially suitable for detection of conducting media (water, etc.). It is less applicable for badly or non conducting media (oils or fatty liquids), conducting foaming liquids or media causing electrically isolating deposits on the electrodes.

Description:

The measuring method for level detection is based on the conductive principle, i.e. the electrical conductivity of the media is monitored. If the switching amplifier detects a value below the set conductivity the state "media detected" is output, otherwise "no media".

Specifications:

Power supply: 18 V ... 250 V AC/DC
wide-range power supply
Power consumption: < 2 VA

2 signal inputs:

Triggering level: < 100 kΩ
Response time: 2 s

1 Relay output:

Contact: change-over contact,
potential-free
Switching voltage: ≤ 250 V AC
Switching current: ≤ 5 A (ohmic load)

Protection class:

ALSCHU 300 SP: IP20
ALSCHU 300 FG: IP65

Electric connection:

GEWAS 300 SP: connection via screw-type
terminal
GEWAS 300 FG: connection via 3 PG cable
glands and screw
terminals

Working temperature: -20 ... +60 °C
Storage temperature: -40 ... +80 °C
Condensation: not allowed

Housing:

GEWAS 300 SP: snap-on housing for
DIN rail mounting
22.5 x 75 x 110 mm
(W x H x D)
GEWAS 300 FG: field frame
100 x 100 x 60 mm
(W x H x D) without
PG cable glands

Functions / displays:

Red / green LED: display for switching state of relay,
switching state of sensors, status (supply) of device,
status of battery
Acoustic alarm: internal alarm buzzer with battery back-up
(only for GEWAS 300 FG)
Battery back-up: Monitoring and acoustic alarm are ensured even e.g.
during power failures (only for GEWAS 300 FG)
Alarm reset: alarm reset by
GEWAS 300 SP: connection for external push-button
GEWAS 300 FG: push-button at front side

Options:

- **2AA** (only for GEWAS 300 FG)
additional alarm output, internal alarm no longer applicable

Accessories:

GSS-1 level sensor, 2m cable
(floating switch) for electrically non-conducting media

GNS-1 level sensor 2-pole
(stainless steel electrode)

GSAS-1 magnetic contact
plug-in and self-adhesive

OEM- / customer-specific designs

You have not found a device fulfilling all your requirements completely? No problem, we can modify the devices to your specific needs.

I.) Optical customization

- Colours of housing according to your wishes

If we have the colour in stock, we can change the default cover colour to your desired one.

For larger orders it is also possible to have the housings specifically manufactured to your wishes.

- Modified label

Do you want your logo on the device or the type designation matching to your name policy?

II.) Hardware and software modifications

To a certain extent the hardware or software can be modified to your requirements.

For example this are realized modifications to customer's specifications:

- Modifying the hardware to another probe characteristic

- Creating an additional material characteristic for the GMH 38xx - series

- and many more

III.) Customer-specific developments

If there is no device in our standard product proposal fulfilling your individual requirements, there is the possibility to develop a device according to your specifications.

Please contact us, we'll do our best to fulfil your wishes ...

Synergies

The merger of the companies



results in enhanced competence, optimum service and best advice for all aspects of measurement and control technology.

We offer so a complete product portfolio for the requirements of the following segments:

Laboratory Measurement

Industrial Electronics

Process Engineering

Industrial Measurement

Test Bench Measurement

www.ghm-messtechnik.de

A subsidiary of
GHM
MESSTECHNIK

Alphabetic Index

A-10	107	GES 500	124	GMH 55 ...	32/33	GSN 24 ...	87	GZ-11	51
AAG2M	57	GES 900	124	GMI 15	22	GSOFT 40K	90	Heumesssonde	15
AGL ...	135	GEWAS 18 ...	139	GMK 38	24	GSOFT 3050	58	HLR 50 A	74
AKL 1P	93	GEWAS 191 ...	140	GMK 100	23	GSP 91...	24	IR-CT 20	103
ALSCHU 300 ...	137	GEWAS 200	140	GMK 210	23	GSS-F25	115	K31, K32	70
ALSCHU 480 / 485	138	GEWAS 300	141	GMK 3810	25	GSS-1	139	K48	71
Antenne GSM	94	GFN ...	18	GMR 100	25	GSS-1S	137	K50..	8
APG ...	74	GFTB 100 ...	20	GMS 300/91	24	GST 91	24	KCL 3 M	35
CaCl	35	GFTH 95	19	GMSD ...	42/43	GST 3810	25	KFZ 2000	61
CR 2032	79	GFTH 200 ...	19	GMTL 1826-MT4	13	GT1-CO	108	KM4P ...	112
D53 TP50D	74	GGF 175	122	GMUD	106	GT10-CO2-1R	108	KOH 100	52
D53-3P	74	GGF 200	125	GMV	138/139	GTA 0420	76	LAN 3000	94
DFM 232 SET	94	GGO 370...	51	GNG 09	57	GTD 1100	47	LC ...	119
EAK 36	65	GHE 91	24	GNG 09-3.5KS	137	GTE 130 OK	125	LF ...	29
EASYBUS.DLL	93	GHTU ...	104	GNG 10	57	GTF 35	121	LFE ...	111
EASYBus-Configurator91		GIA 010 N ...	60	GNG 10/3000	57	GTF 38	24	MINAL ...	137
EASYControl net	91	GIA 0420 N ...	60	GNG 12-LE	94	GTF 55 B	33	MINIDIN 4S	57
EASYLOG 24RFT ...	81	GIA 0420 VO ...	72	GNG 12/ ...	75	GTF 101	130	MINISOFT	79
EASYLOG 40BIN	82	GIA 0420 WKT ...	72	GNG 24/ ...	75	GTF 101 - Ex	129	MODEM ...	94
EASYLOG 40IMP ...	80	GIA 20 EB ...	62	GNG 220 ...	75	GTF 101-5/ ...	127	MP 8082	74
EASYLOG 40K ...	80	GIA 2000	65	GNG 89 ...	57	GTF 101-N03 ...	128	MSD ...	43
EASYLOG 40NS ...	81	GIA 2448 ...	61	GNR 10	75	GTF 102	130	MSK 100	53
EASYLOG 80CL	82	GIM 530 MS	13	GNS 132A	94	GTF 102 - Ex	129	MU 500 ...	102
EB 2000 MC	89	GIM 1840-ST25 XB	14	GNS-1S	139	GTF 103	131	MWF 100	132
EB 3000 ...	88	GIM 3590	14	GNS-3P ...	117	GTF 103 - Ex	129	NKU 1200...	134
EBB ... IN	93	GIR 2000 Pt ...	69	GNS-KIT	119	GTF 103 HT-S	110	NKU 1700	134
EBB ... OUT	94	GIR 230 ...	63	GNS-C ...	118	GTF 103 OS	131	NST 1...	134
EBG-CO-1R	87	GIR 2002	66	GNS-SCV ...	116	GTF 103/RT420	100	OB-700	133
EBG-CO2-1R	87	GIR 2002 NS / DIF ...	68	GNT 0520	105	GTF 104 ...	131	OXY 36 ...	109
EBHT ...	84	GIR2002 / SW	68	GNTP	98	GTF 175 ...	122	P2P, P3P, P4P	135
EBN ...	86	GIR 2002 PID	66	GOEL 370 ...	51	GTF 199	69	PHL ...	33
EBS 20M / 60M	58	GIR 2002 PID / SW	68	GOF 112 ...	133	GTF 200 Pt100 ...	130	Profilab-Expert	58, 93
EBSK ...	93	GITT 01 ...	101	GOF 115 ...	133	GTF 230 S	63	PW 25	23
EBT ...	85	GKF 125	124	GOF 120 ...	133	GTF 300 ...	125	R38	70
EBT-IF ...	86	GKF 250	125	GOF 130 ...	122	GTF 300 GS	125	RC-Glied	74
EBW ...	92	GKK ...	56	GOF 175 ...	122	GTF 400	124	rotaro3	55
ecotach	55	GKL ...	27	GOF 200 HO	123	GTF 401 ...	121	RRI ...	113
EF...	112	GKN 3600	52	GOF 400 ...	123	GTF 601 ...	121	RT 420 ...	100
EL-USB-...	78	GKS 3600	52	GOF 401 Mini	121	GTF 900	124	RW-015HKL	118
EPI	114	GKV ...	134	GOF 500 ...	123	GTF 1000 AL	124	RWI-016 ...	118
ESA 100	53	GLF 100 ...	27	GOF 900 HO	123	GTF 1200 ...	124	S2P, S4P	135
ESA 369	51	GLF 175 ...	122	GOK 91	24	GTF 1400 B	128	S-10 ..., S-11 ...	107
ESK-1	93	GLF 401 Mini	121	GOG ...	50	GTF 1500/300	128	SCX ...	76
EST...	135	GLG 1300	57	GOO 370 ...	51	GTF 1500/500	128	SET 38...	24, 25
FCM...	113	GLI 9V	57	GOX 20	52	GTF 2000 ...	122	ST 500 - Ex ...	102
FH-Messing	114	GLMU ...	111	GOX 100 ...	51	GTH 83 EG	64	ST ...	56
FKH...	114	GLP 91	24	GPAD 38	24	GTH 175/Pt ...	9	STE ...	18
FS3T	62	GLS 500	125	GPB 3300	47	GTH 1150	11	STS ...	18
G2P, G3P, G4P	135	GMDP	106	GPD ...	76	GTH 1150 EG	64	T2P, T3P, T4P	135
GAD ...	35	GMF 1...	128	GPF 100	34	GTH 1170	11	T03 BU /WE	99
GAF 200	124	GMF 3 ...	128	GPH 014 ...	36	GTH 2448/ ...	61	TA 888	54
GAK 9 V	57	GMF 2...	125	GPH ...	35	GTL	116	Testnormal	5
GAK 1400	35	GMFL	135	GPHU 014 MP ...	110	GTL 130	124	TF 101 ...	132
GAM 3000	57	GMH 175	9	GPRT 1400 AN ...	36	GTMU	97	TLK 43	71
GAS 100	53	GMH 1150	11	GPT ...	76	GTMU - IF ...	99	TFS 0100 E	18
GAS 3600	52	GMH 1170	11	GPV 220	76	GTMU-MP	96	TF1 ...	103
GAZ-1	137	GMH 1300	56	GR 10	75	GTMU-OMU	97	T-Logg 100 ...	79
GBF 1550	128	GMH 2710 ...	8	GRA 010 VO	73	GTMU-2R-OMU	97	T-Logg 120 ...	79
GBS ...	116	GMH 3000.DLL	58	GRA 0420 VO	73	GTO 130 OK	125	T-Logg 160 ...	79
GBSK 91	24	GMH 3111 ...	40	GRA 010 WK	73	GTP	98	USB 100	79
GBSL 91	24	GMH 3151 ...	41	GRA 0420 WK	73	GTP-SG	98	USB 3100 N	57
GCO 100	53	GMH 3156 ...	41	GRF 200	125	GTT...	126	USB 5100	39
GDH ... AN	48	GMH 3161 ...	44/45	GRHU ...	104	GTT 1150 OK	125	USB-Adapter	57
GDH 200 ...	46	GMH 3181 ...	44/45	GRL 100	35	GTU 300/152	76	VD 120	34
GDUSB 1000	78	GMH 32 ...	10	GRMU 2000 MP	110	GTU-2R-OMU	97	VEKA ...	137
GDZ ...	42/43	GMH 33 ...	17	GRO 200 ...	130	GTZ 300	123	VEKA 3105	57
GE 014	36	GMH 3430	30	GRP 100	35	GVA 0430	54	VISION 2008	115
GE 1...	35/36	GMH 35 ...	34	GRV 100	53	GWA 1214	43	VKA 1m	135
GEF 38	24	GMH 3610	52	GRS0 ...	93	GWA 1Z	35	VSL 2P	93
GEG 91	24	GMH 3630	52	GRS 31 ...	57	GWL 10G	135	VTH 25MS-180	115
GEH 1	56	GMH 3691 ...	50	GSA ...	57	GWF-1 ...	137	WP ...	4
GES 21K	124	GMH 3710 ...	7	GSAS-1S	137	GWH ...	93	ZOT 369	53
GES 38	24	GMH 3750 ...	7	GSE 91	24/25	GWO 3600	52		
GES 130	124	GMH 3810	25	GSF 38 ...	24	GWO 3600 MU	109		
GES 175 ...	122	GMH 3830 ...	24	GSG 91	24	GWOK 01	109		
GES 401 ...	121	GMH 3850	25	GSH 8922	54	GWZ-01	27		
		GMH 51 ...	38/39	GSKA 3600	52	GZ-0 ...	87		
		GMH 54 ...	28/29	GSMU ...	105	GZ-10	53		



Please visit our website:
www.greisinger.de

- Launch of new products
- Price information
- Direct ordering facility
- Software download
- Instruction manual
- FAQ area

Catalog prices valid as of January 01.01.2011

Catalog is subject to technical and commercial changes!

GREISINGER
 — electronic —



GREISINGER electronic GmbH

D - 93128 Regenstauf • Hans-Sachs-Straße 26

+49 (0) 94 02 / 93 83 - 0

www.greisinger.de

+49 (0) 94 02 / 93 83 - 33

info@greisinger.de