

NK, NKG

Installation and operating instructions



Original installation and operating instructions.

CONTENTS

	Page
1. Symbols used in this document	2
2. General information	2
3. Receiving the product	2
3.1 Delivery	2
3.2 Transporting the product	2
3.3 Handling	3
3.4 Storing the product	3
4. Identification	3
4.1 Nameplate	3
4.2 Type key	4
5. Applications	6
5.1 Pumped liquids	6
6. Operating conditions	7
6.1 Ambient temperature and altitude	7
6.2 Liquid temperature	7
6.3 Maximum operating pressure	7
6.4 Minimum inlet pressure	7
6.5 Maximum inlet pressure	7
6.6 Minimum flow rate	7
6.7 Maximum flow rate	7
6.8 Shaft seals	8
7. Mechanical installation	9
7.1 Pump location	9
7.2 Foundation and grouting of horizontally mounted NK, NKG pumps with base frame	9
7.3 Alignment	12
7.4 Pipework	15
7.5 Vibration damping	15
7.6 Expansion joints	16
7.7 Stuffing box piping	16
7.8 Bearing bracket	17
7.9 Bearing monitoring	18
7.10 Pressure gauge and mano-vacuum gauge	18
7.11 Ammeter	18
8. Flange forces and torques	19
9. Electrical connection	20
9.1 Motor protection	20
9.2 Frequency converter operation	20
10. Commissioning and startup	20
10.1 General information	20
10.2 Commissioning	20
10.3 Priming	21
10.4 Checking the direction of rotation	21
10.5 Startup	21
10.6 Shaft seal run-in period	22
10.7 Motor start/stop	22
10.8 Reference readings of monitoring equipment	22
11. Maintenance	22
11.1 Pump	22
11.2 Lubrication of bearings in bearing bracket	23
11.3 Monitoring equipment	25
11.4 Motor	25
12. Periods of inactivity and frost protection	25
13. Service	26
13.1 Service kits	26
14. Technical data	26
14.1 Electrical data	26
14.2 Sound pressure level	26
14.3 Belt drive	26
14.4 Operation with combustion engine	26
15. Fault finding	27
16. Disposal	28



Warning

Prior to installation, read these installation and operating instructions. Installation and operation must comply with local regulations and accepted codes of good practice.

1. Symbols used in this document



Warning

If these safety instructions are not observed, it may result in personal injury.

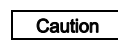

Caution

If these safety instructions are not observed, it may result in malfunction or damage to the equipment.

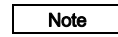

Note

Notes or instructions that make the job easier and ensure safe operation.

2. General information

NK, NKG are non-self-priming, single stage, centrifugal volute pumps with axial suction port and radial discharge port.

NK pumps comply with EN 733.

NKG pumps comply with ISO 2858.

3. Receiving the product

3.1 Delivery

The pumps are tested 100 % before leaving the factory. The test includes a function test where the pump performance is measured to ensure that the pump meets the requirements of relevant standards. Test certificates are available from Grundfos. After the installation, the alignment of pump and motor must be checked again. See section [7.3 Alignment](#).

3.2 Transporting the product

Always transport the pump in the specified position. During transport, the pump must be fastened securely to prevent damage to the shaft and shaft seal caused by excessive vibrations and knocks. The pump must not be lifted by the shaft.



Warning

Pay attention to the pump weight, and take precautions to prevent personal injury if the pump should topple or fall by accident.

3.3 Handling



Warning

Motors from 4 kW and up are supplied with lifting eyes which must not be used for lifting the entire pump unit.

Lift the pumps by means of nylon straps and shackles.

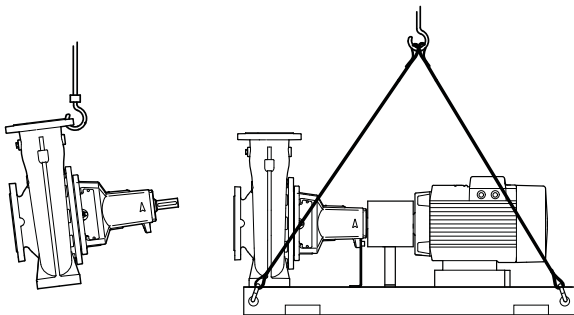

Fig. 1 Correct lifting of pump

TM03 3948 1206

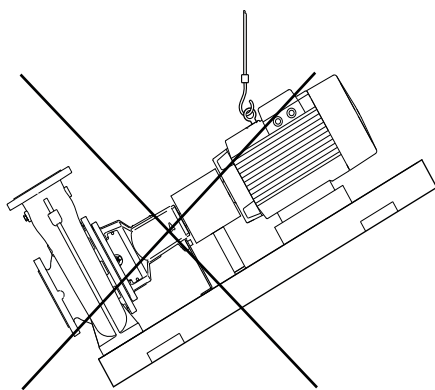

Fig. 2 Incorrect lifting of pump

TM03 3769 1006

3.4 Storing the product

The contractor must inspect the equipment on delivery and make sure that it is stored in such a way that corrosion and damage are avoided.

If more than six months will pass before the equipment is put into operation, please consider applying a suitable corrosion inhibitor to the internal pump parts.

Make sure that the corrosion inhibitor used does not affect the rubber parts with which it comes into contact.

Make sure that the corrosion inhibitor can be easily removed.

To prevent water, dust, etc. from entering the pump, all openings must be kept covered until the pipes are fitted. The cost of having to dismantle the pump during startup to remove foreign objects can be very high.

4. Identification

4.1 Nameplate

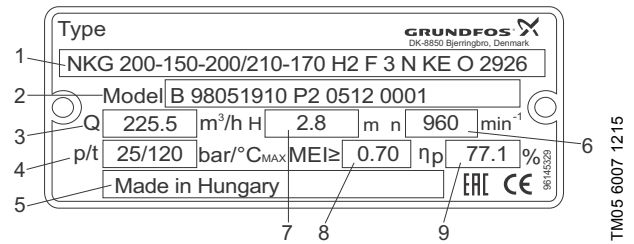

Fig. 3 Example of NKG nameplate

TM05 6007 1215

Legend

Pos.	Description
1	Type designation
2	Model
3	Rated flow
4	Pressure rating or maximum temperature
5	Country of origin
6	Rated speed
7	Pump head
8	Minimum efficiency index
9	Hydraulic pump efficiency at optimum efficiency point

4.2 Type key

Model B

Example 1, pump design according to EN 733	NK	32	-125	.1	/142	A1	F	1	A	E	S	BAQE
Example 2, pump design according to ISO 2858	NKG	200	-150	-200	/210-170	H2	F	3	N	KE	O	2926
Type range												
Nominal diameter of suction port (DN)												
Nominal diameter of discharge port (DN)												
Nominal impeller diameter [mm]												
Reduced performance: .1												
Actual impeller diameter [mm]												
Code for pump version; the codes may be combined												
A1 Basic version, grease-lubricated standard bearing design, standard coupling												
A2 Basic version, grease-lubricated standard bearing design, spacer coupling												
B Oversize motor												
E With ATEX approval, certificate or test report, the second character of the pump version code is an E												
G1 Grease-lubricated heavy-duty bearing design, standard coupling												
G2 Grease-lubricated heavy-duty bearing design, spacer coupling												
H1 Oil-lubricated heavy-duty bearing design, standard coupling												
H2 Oil-lubricated heavy-duty bearing design, spacer coupling												
I1 Pump without motor, grease-lubricated standard bearing design, standard coupling												
I2 Pump without motor, grease-lubricated standard bearing design, spacer coupling												
J1 Pump without motor, grease-lubricated heavy-duty bearing design, standard coupling												
J2 Pump without motor, grease-lubricated heavy-duty bearing design, spacer coupling												
K1 Pump without motor, oil-lubricated heavy-duty bearing design, standard coupling												
K2 Pump without motor, oil-lubricated heavy-duty bearing design, spacer coupling												
Y1 Bare shaft pump, grease-lubricated standard bearing design												
W1 Bare shaft pump, grease-lubricated heavy-duty bearing design												
Z1 Bare shaft pump, oil-lubricated heavy-duty bearing design												
X Special version; used in case of further customisation than already listed												
Pipe connection												
E Table E flange												
F DIN flange												
G ANSI flange												
J JIS flange												
Flange pressure rating (PN - rated pressure)												
1 10 bar												
2 16 bar												
3 25 bar												
4 40 bar												
5 Other pressure rating												
Materials												
	Pump housing	Impeller	Wear ring	Shaft								
A	EN-GJL-250	EN-GJL-200	Bronze/brass	1.4021/1.4034								
B	EN-GJL-250	Bronze CuSn10	Bronze/brass	1.4021/1.4034								
C	EN-GJL-250	EN-GJL-200	Bronze/brass	1.4401								
D	EN-GJL-250	Bronze CuSn10	Bronze/brass	1.4401								
E	EN-GJL-250	EN-GJL-200	EN-GJL-250	1.4021/1.4034								
F	EN-GJL-250	Bronze CuSn10	EN-GJL-250	1.4021/1.4034								
G	EN-GJL-250	EN-GJL-200	EN-GJL-250	1.4401								
H	EN-GJL-250	Bronze CuSn10	EN-GJL-250	1.4401								
I	1.4408	1.4408	1.4517	1.4462								
J	1.4408	1.4408	Carbon-graphite-filled PTFE (Graflon®)	1.4462								
K	1.4408	1.4408	1.4517	1.4401								
L	1.4517	1.4517	1.4517	1.4462								
M	1.4408	1.4517	1.4517	1.4401								
N	1.4408	1.4408	Carbon-graphite-filled PTFE (Graflon®)	1.4401								

Example 1, pump design according to EN 733				NK	32	-125	.1	/142	A1	F	1	A	E	S	BAQE
Example 2, pump design according to ISO 2858				NKG	200	-150	-200	/210-170	H2	F	3	N	KE	O	2926
P	1.4408	1.4517	Carbon-graphite-filled PTFE (Graflon®)	1.4401											
R	1.4517	1.4517	Carbon-graphite-filled PTFE (Graflon®)	1.4462											
S	EN-GJL-250	1.4408	Bronze/brass	1.4401											
T	EN-GJL-250	1.4517	Bronze/brass	1.4462											
U	1.4408	1.4517	1.4517	1.4462											
W	1.4408	1.4517	Carbon-graphite-filled PTFE (Graflon®)	1.4462											
X	Special version														
Rubber parts in pump															
The first letter indicates material of O-rings for pump cover and seal cover. O-ring for seal cover is only for double seal arrangements															
The second letter indicates material of O-ring for seal housing. O-ring for seal housing is only for double seal arrangements															
E EPDM															
F FXM (Fluoraz®)															
K FFKM (Kalrez®)															
M FEPS (PTFE-sheathed silicone O-ring)															
V FKM (Viton®)															
X HNBR															
Shaft seal arrangement															
B Stuffing box															
C Cartridge seal, single															
D Cartridge seal, double															
O Back-to-back, double seal															
P Tandem, double seal															
S Single seal															
Shaft seal(s) in pump															
Letter or digit code for mechanical shaft seal and shaft seal rubber parts															
4 letters: Single mechanical shaft seal, such as BQQE, or single cartridge seal, such as HBQV															
4 digits: Double seal solution; example 2716, where 27 is DQQV, primary seal, and 16 is BQQV, secondary seal; double cartridge seal; example 5150, where 51 is HQQU, primary seal, and 50 is HBQV, secondary seal															
The relation between letters and digits of the shaft seals is described on page 6.															

Example 1 shows an NK 32-125.1 pump with these characteristics:

- reduced performance
- 142 mm impeller
- grease-lubricated standard bearing design
- standard coupling
- DIN flange to EN 1092-2 pipework connection
- 10 bar flange pressure rating
- cast iron pump housing, EN-GJL-250
- cast iron impeller, EN-GJL-200
- bronze/brass wear ring
- stainless steel shaft, EN 1.4021/1.4034
- EPDM O-ring for pump cover
- single shaft seal arrangement
- BAQE shaft seal

Example 2 shows an NKG 200-150-200 pump with these characteristics:

- 210-170 mm conical impeller
- grease-lubricated heavy-duty bearing design
- spacer coupling
- DIN flange to EN 1092-2 pipework connection
- 25 bar flange pressure rating
- stainless steel pump housing, EN 1.4408
- stainless steel impeller, EN 1.4408
- carbon-graphite-filled PTFE (Graflon®) wear ring
- stainless steel shaft, EN 1.4401
- FFKM O-rings for pump cover and seal cover
- EPDM O-ring for seal housing
- back-to-back double shaft seal arrangement
- primary shaft seal: DQQK
- secondary shaft seal: DQQE

4.2.1 Codes for shaft seals

The digits are only used for double shaft seal solutions.

Digits	Letters	Description
10	BAQE	Single mechanical shaft seal
11	BAQV	Single mechanical shaft seal
12	BBQE	Single mechanical shaft seal
13	BBQV	Single mechanical shaft seal
14	BQBE	Single mechanical shaft seal
15	BQQE	Single mechanical shaft seal
16	BQQV	Single mechanical shaft seal
17	GQQE	Single mechanical shaft seal
18	GQQV	Single mechanical shaft seal
19	AQAE	Single mechanical shaft seal
20	AQAV	Single mechanical shaft seal
21	AQQE	Single mechanical shaft seal
22	AQQV	Single mechanical shaft seal
23	AQQX	Single mechanical shaft seal
24	AQQK	Single mechanical shaft seal
25	DAQF	Single mechanical shaft seal
26	DQQE	Single mechanical shaft seal
27	DQQV	Single mechanical shaft seal
28	DQQX	Single mechanical shaft seal
29	DQQK	Single mechanical shaft seal
50	HBQV	Cartridge seal
51	HQQU	Cartridge seal
52	HAQK	Cartridge seal
	SNEA	Stuffing box
	SNEB	Stuffing box
	SNEC	Stuffing box
	SNED	Stuffing box
	SNOA	Stuffing box
	SNOB	Stuffing box
	SNOC	Stuffing box
	SNOD	Stuffing box
	SNFA	Stuffing box
	SNFB	Stuffing box
	SNFC	Stuffing box
	SNFD	Stuffing box

4.2.2 Letter codes for shaft seals

Example: 10 is BAQE	B	A	Q	E
Shaft seal type				
A				
B				
D				
G				
H				
Material, rotating seal face				
A				
B				
Q				

Example: 10 is BAQE	B	A	Q	E
Material, stationary seat				
A				
B				
Q				
Material, secondary seal and other rubber and composite parts, except the wear ring				
E				
V				
F				
K				
X				
U				

For a thorough description of shaft seal types and materials, see the data booklet "NB, NBG, NK, NKG, NBE, NBGE, NKE, NKGE - Custom-built pumps according to EN 733 and ISO 2858".

4.2.3 Letter codes for stuffing boxes

Example:	S	N	E	A
Stuffing box type				
S				
Cooling method				
N				
Barrier liquid				
E				
F				
O				
Material				
A				
B				
C				
D				

For a thorough description of stuffing boxes and materials, see the data booklet "NB, NBG, NK, NKG, NBE, NBGE, NKE, NKGE - Custom-built pumps according to EN 733 and ISO 2858".

5. Applications

5.1 Pumped liquids

Clean, thin, non-explosive liquids without solid particles or fibres. The pumped liquid must not attack the pump materials chemically.

6. Operating conditions

6.1 Ambient temperature and altitude

The ambient temperature and the installation altitude are important factors for the motor life as they affect the life of the bearings and the insulation system.

If the ambient temperature exceeds the recommended maximum ambient temperature or the installation altitude exceeds the recommended maximum altitude above sea level, see fig. 4, the motor must not be fully loaded due to the low density and consequently low cooling effect of the air. In such cases, it may be necessary to use a motor with a higher output.

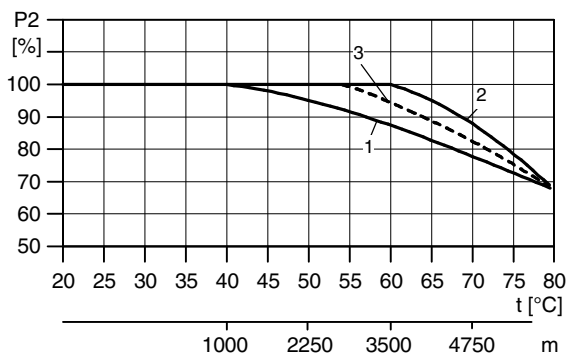

Fig. 4 The maximum motor output depends on the ambient temperature and altitude

Legend

Pos.	Description
1	0.25 - 0.55 kW MG motors
2	0.75 - 22 kW MG motors, IE2/IE3
	0.75 - 450 kW MMG-H motors, IE2
3	0.75 - 462 kW Siemens motors, IE2

Example: A pump with a 1.1 kW IE2 MG motor: If this pump is installed 4750 m above sea level, the motor must not be loaded more than 88 % of the rated output. At an ambient temperature of 75 °C, the motor must not be loaded more than 78 % of the rated output. If the pump is installed 4750 m above sea level at an ambient temperature of 75 °C, the motor must not be loaded more than 88 % x 78 % equal to 68.6 % of the rated output.

6.2 Liquid temperature

-40 - +140 °C.

The maximum liquid temperature is stated on the pump nameplate. It depends on the shaft seal chosen.

For EN-GJL-250 cast iron pump housings, local regulations may not allow liquid temperatures above +120 °C.

6.3 Maximum operating pressure

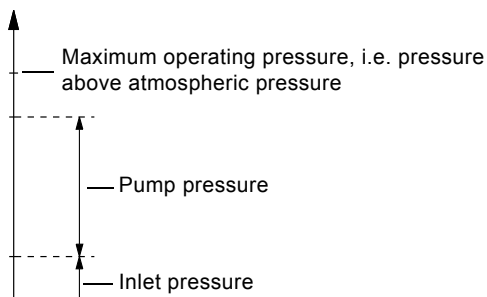

Fig. 5 Pressures in the pump

The inlet pressure + the pump pressure must be lower than the maximum operating pressure stated on the pump nameplate. Operation against a closed discharge valve gives the highest operating pressure.

6.4 Minimum inlet pressure

Pay attention to the minimum inlet pressure to avoid cavitation. The risk of cavitation is higher in the following situations:

- The liquid temperature is high.
- The flow rate is considerably higher than the pump's rated flow rate.
- The pump is operating in an open system with suction lift.
- The liquid is sucked through long pipes.
- The inlet conditions are poor.
- The operating pressure is low.

6.5 Maximum inlet pressure

The inlet pressure + the pump pressure must be lower than the maximum operating pressure stated on the pump nameplate. Operation against a closed discharge valve gives the highest operating pressure.

6.6 Minimum flow rate

The pump must not run against a closed discharge valve as this will cause an increase in temperature/formation of steam in the pump. This may cause shaft damage, impeller erosion, short life of bearings and damage to stuffing boxes or mechanical shaft seals due to stress or vibration. The continuous flow rate must be at least 10 % of the rated flow rate. The rated flow rate is stated on the pump nameplate.

6.7 Maximum flow rate

The maximum flow rate must not be exceeded as otherwise there is a risk of for instance cavitation and overload.

The minimum and maximum flow rates can be read either from the performance curve pages in the relevant data booklets or from a curve for a specific pump when selecting it in Grundfos Product Center.

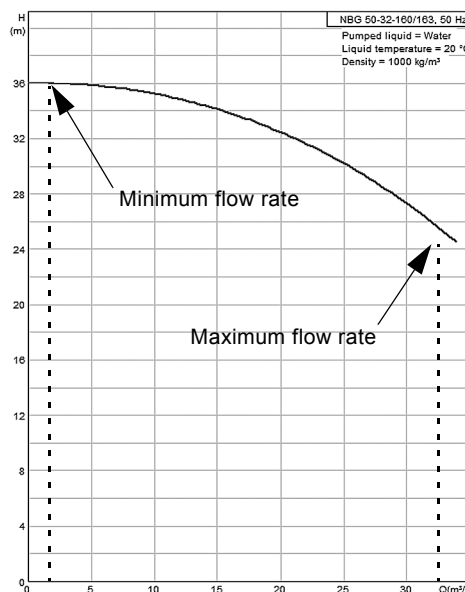

Fig. 6 Example from Grundfos Product Center showing minimum and maximum flow rate

TM04 4914 2209

TM04 0062 4907

TM05 2444 5111





6.8 Shaft seals

Mechanical shaft seals

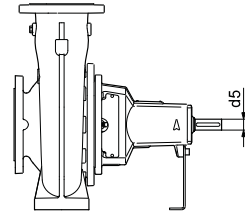
The operating range of the seals is described for two main applications: pumping of water or pumping of coolants. Seals with a temperature range of 0 °C and up are mainly used for pumping water, while seals for temperatures below 0 °C are mainly intended for coolants.

Note: We do not recommend operation at maximum temperature and maximum pressure at the same time as the seal life will be reduced and periodical noise will occur.



Shaft seal diameter [mm]		28, 38	48	55	60
d5 [mm]		24, 32	42	48	60
Shaft seal type	Seal faces	Rubber	Code	Temperature range	Max. pressure [bar]
 Bellows seal, type B, unbalanced	AQ ₁	EPDM	BAQE	0-120 °C	16 16 16 16
	AQ ₁	FKM	BAQV	0-90 °C	16 16 16 16
	BQ ₁	EPDM	BBQE	0-120 °C	16 16 16 16
	BQ ₁	FKM	BBQV	0-90 °C	16 16 16 16
	Q ₁ B	EPDM	BQBE	0-100 °C	16 - - -
	Q ₇ Q ₇	EPDM	BQQE	-25 - +120 °C	16 16 16 16
	Q ₇ Q ₇	FKM	BQQV	-10 - +90 °C	16 16 16 16
 Bellows seal, type B, unbalanced with reduced seal faces	Q ₁ Q ₁	EPDM	GQQE	-25 - +60 °C	16 16 16 16
	Q ₁ Q ₁	FKM	GQQV	-10 - +60 °C	16 16 16 16
 O-ring seal, type A, unbalanced	Q ₁ A	EPDM	AQAE	0-120 °C	16 16 16 16
	Q ₁ A	FKM	AQAV	0-90 °C	16 16 16 16
	Q ₁ Q ₁	EPDM	AQQE	-25 - +90 °C	16 16 16 16
	Q ₁ Q ₁	FKM	AQQV	-10 - +90 °C	16 16 16 16
	Q ₁ Q ₁	HNBR	AQQX	-15 - +90 °C	16 16 16 16
	Q ₁ Q ₁	FFKM	AQQK	0-90 °C	16 16 16 16
 O-ring seal, type D, balanced	AQ ₁	FXM	DAQF	0-140 °C	25 25 25 25
	Q ₆ Q ₆	EPDM	DQQE	-20 - +120 °C	25 25 25 25
	Q ₆ Q ₆	FKM	DQQV	-10 - +90 °C	25 25 25 25
	Q ₆ Q ₆	HNBR	DQQX	-15 - +120 °C	25 25 25 25
	Q ₆ Q ₆	FFKM	DQQK	0-120 °C	25 25 25 25

Stuffing box

	Code	Temperature range	Max. pressure [bar]
Stuffing box without cooling, with internal barrier liquid	SNE		
Stuffing box without cooling, without barrier liquid	SNO	-30 - +120 °C	16
Stuffing box without cooling, with external barrier liquid	SNF		

7. Mechanical installation

7.1 Pump location

The pump must be sited in a well-ventilated, but frost-free location.



Warning

When pumping hot or cold liquids, make sure that persons cannot accidentally come into contact with hot or cold surfaces.

For inspection and repair, allow suitable clearances for pump or motor removal.

- Pumps fitted with motors up to and including 4 kW require a 0.3 m clearance behind the motor.
- Pumps fitted with motors of 5.5 kW and up require a 0.3 m clearance behind the motor and at least a 1 m clearance above the motor to allow the use of lifting equipment.

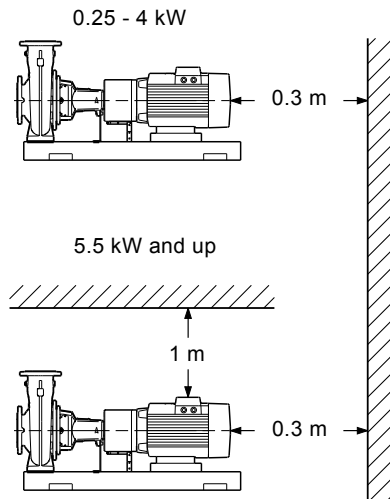

Fig. 7 Clearance behind the motor

7.2 Foundation and grouting of horizontally mounted NK, NKG pumps with base frame

We recommend that you install the pump on a plane and rigid concrete foundation which is heavy enough to provide permanent support for the entire pump. The foundation must be capable of absorbing any vibration, normal strain or shock. As a rule of thumb, the weight of the concrete foundation must be 1.5 times the weight of the pump.

The foundation must be 100 mm larger than the base frame on all four sides. See fig. 8.

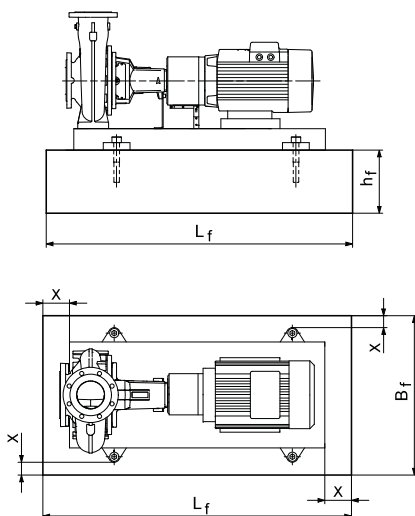

Fig. 8 Foundation, X equal to minimum 100 mm

The minimum height of the foundation, h_f , can then be calculated:

$$h_f = \frac{m_{\text{pump}} \times 1.5}{L_f \times B_f \times \delta_{\text{concrete}}}$$

The density, δ , of concrete is usually taken as 2,200 kg/m³.

Place the pump on the foundation, and fasten it. The base frame must be supported under its entire area. See fig. 9.

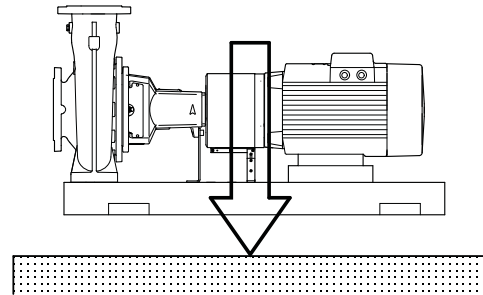

Fig. 9 Correct foundation

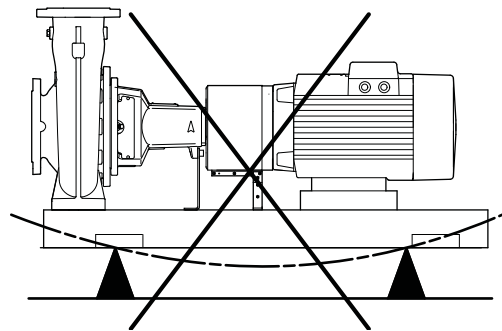

Fig. 10 Incorrect foundation

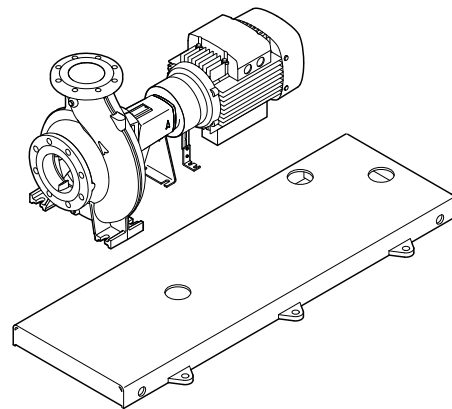

Fig. 11 Base frame with pouring holes

It is important to prepare a good foundation prior to the installation of the pump.

NK, NKG pumps with base frame are always prepared for grouting.

For NK, NKG pumps with 2-pole motors equal to or bigger than 55 kW, grouting of the base frame is mandatory in order to prevent vibration energy from the rotating motor and liquid flow to evolve.

	P2 lower than or equal to 45 kW	P2 equal to or higher than 55 kW
2-pole	Grouting optional	Grouting mandatory
4-pole	Grouting optional	
6-pole	Grouting optional	

TM03 3950 1206

TM03 4324 1206

TM03 4587 2206

TM05 3727 1612

TM03 3771 1206

7.2.1 Procedure

1. Preparing the foundation
2. Levelling of the base frame
3. Preliminary alignment
4. Grouting
5. Final alignment according to section [7.3 Alignment](#).

1: Preparing the foundation

We recommend the following procedure to ensure a good foundation.

Step	Action	Illustration
1	Use an approved, non-shrinking concrete. Contact your concrete supplier for advice if any doubts. Pour the foundation without interruptions to within 19 to 32 mm of the final level. Use vibrators to ensure that the concrete is evenly distributed. The top surface must be well scored and grooved before the concrete sets. This provides a bonding surface for the grout.	
2	Embed foundation bolts in the concrete. Allow enough bolt length to reach through grout, shims, lower base frame, nuts and washers.	
3	Let the foundation cure for several days before the base frame is levelled and grouted.	

TM03 0190 4707

2: Levelling of the base frame

Step	Action	Illustration
1	Lift/jack up the base frame to the final level 19-32 mm above the concrete foundation, and support the base frame by means of blocks and shims both at the foundation bolts and midway between bolts.	
2	Level the base frame by adding or removing shims under the base frame.	
3	Tighten the foundation bolt nuts against the base frame. Make sure the piping can be aligned to the pump flanges without putting strain on pipes or flanges.	

TM04 0488 0706

TM04 0489 0708

3: Preliminary alignment



Warning

Before starting work on the pump, make sure that the power supply has been switched off and cannot be accidentally switched on again.

The pump and motor are pre-aligned on the base frame from the factory. Some deformation of the base frame may occur during transport and it is therefore essential to check the alignment at the installation site prior to final grouting.

A flexible coupling will only compensate for minor misalignments and must not be used to compensate for excessive misalignment of the pump and motor shafts. Inaccurate alignment results in vibration and excessive wear on the bearings, shaft or wear rings.



Warning

Carry out alignment of the motor only, as pipe strain will occur if the pump is shifted.

Carry out alignment of the motor by placing shims of different thickness under the motor. If possible, replace several thin shims with one thick shim.

See section [7.3 Alignment](#).

4: Grouting

Grouting compensates for an uneven foundation, distributes the weight of the unit, dampens vibrations and prevents shifting. Use an approved, non-shrinking grout. If you have questions or doubts about the grouting, please contact an expert on grouting.

Step	Action	Illustration
1	<p>Embed reinforcing steel bars into the foundation by means of 2K anchor adhesive glue.</p> <p>The number of steel bars depends on the size of the base frame, but it is advisable to distribute a minimum of 20 bars evenly over the whole area of the base frame. The free end of the steel bar must be $\frac{2}{3}$ the height of the base frame to ensure a proper grouting.</p>	
2	<p>Soak top of concrete foundation thoroughly, then remove surface water.</p>	
3	<p>Ensure proper shuttering at both ends of the base frame.</p>	
4	<p>If necessary, check the levelling of the base frame again before grouting. Pour non-shrinking grout through the openings of the base frame until the space underneath the base frame has been filled completely.</p> <p>Fill the formwork with grout up to the base frame top level. Allow the grout to dry thoroughly before attaching piping to the pump. 24 hours is sufficient time with approved grouting procedure.</p> <p>When the grout has thoroughly hardened, check the foundation bolt nuts, and tighten, if necessary.</p> <p>Approximately two weeks after the grout has been poured, or when the grout has thoroughly dried, apply an oil-based paint to the exposed edges of the grout to prevent the grout from getting into contact with air and moisture.</p>	

TM04-0490 0708 - TM04-0491 0708

TM03-4590 2206

TM03-2946 4707

7.3 Alignment

7.3.1 General information

When a complete unit is supplied assembled from the factory, the coupling halves have been accurately aligned by means of foil inserted under the pump and motor mounting surfaces as required.

As the pump/motor alignment may be affected during transport and installation, it must always be checked again before starting the pump.

It is important to check the final alignment when the pump has obtained its operating temperature under normal operating conditions.

7.3.2 How to align the unit

It is very important that the pump/motor alignment is carried out correctly. Follow the procedure below.

The values for \varnothing and S2 can be found in the following table. The value for S1 is 0.2 mm.

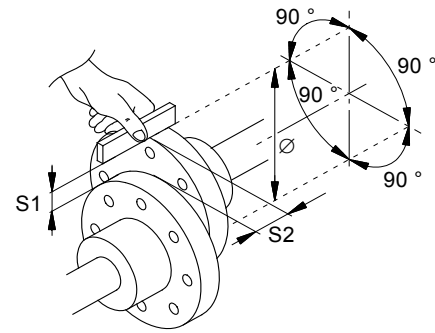

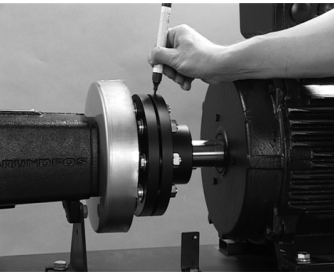
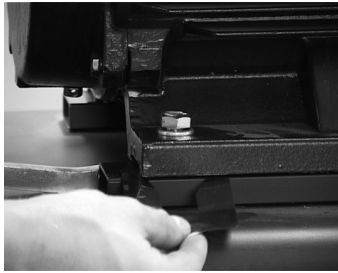
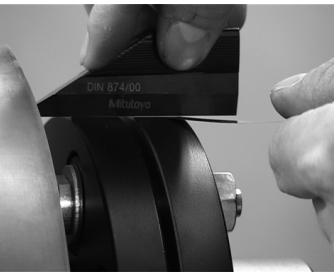
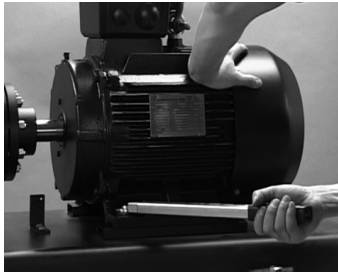
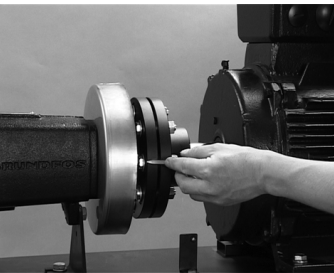
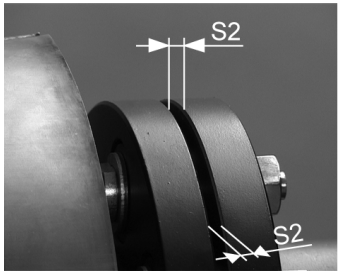



Fig. 12 Alignment

TM01 8753 0800

Aligning the pump and motor with a straight-edge ruler

Step	Action	Step	Action
1	 <p>Make a rough alignment of pump and motor, and tighten the screws in the base frame to the correct torque. See the table Tightening torques on page 15.</p> <p>TM03 8340 1007</p>	5	 <p>Adjust the position of the motor. Loosen the screws that hold the motor in place.</p> <p>TM03 8321 1007</p>
2	 <p>Make a mark on the coupling, for instance with a marker pen.</p> <p>TM03 8301 1007</p>	6	 <p>Insert shims with the required thickness.</p> <p>TM03 8322 1007</p>
3	 <p>Hold a straight-edge ruler against the coupling, and determine the inaccuracy, if any, with a feeler gauge.</p> <p>TM03 8300 1007</p>	7	 <p>Tighten the screws to the correct torque. Go to step 3, and check the alignment once more.</p> <p>TM03 8324 1007</p>
4	 <p>Turn the coupling 90°, and repeat the measurement with straight-edge and feeler gauge. If the measured values are less than 0.2 mm, the alignment is complete. Go to step 8.</p> <p>TM03 8302 1007</p>	8	 <p>Check the gap S2 both vertically and horizontally. See the table Air-gap width S2 on page 15. If the air-gap width is within the tolerances, the alignment is complete. If not, go to step 6.</p> <p>TM03 8325 1007</p>

Aligning the pump and motor with laser equipment

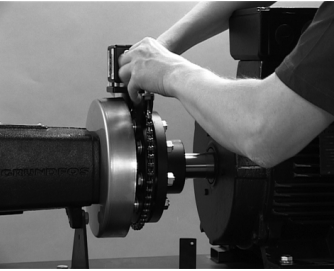
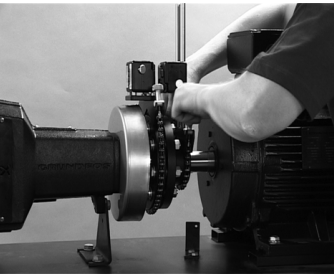
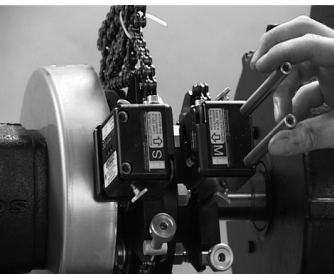
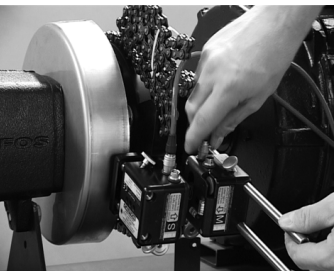
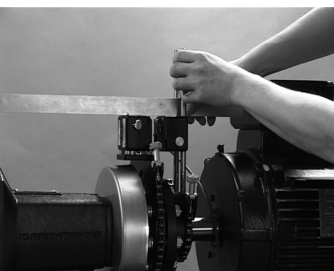
Step	Action
9	 <p>Make a rough alignment of pump and motor, and tighten the screws in the base frame to the correct torque. See the table Tightening torques on page 15.</p> <p>TM03 8340 1007</p>
10	 <p>Fasten one laser bracket to the pump coupling.</p> <p>TM03 8303 1007</p>
11	 <p>Fasten the other laser bracket to the motor coupling.</p> <p>TM03 8304 1007</p>
12	 <p>Place laser unit S, stationary, on the stationary part and laser unit M, movable, on the movable part.</p> <p>TM03 8305 1007</p>
13	 <p>Interconnect the laser units, and connect one laser unit to the control box.</p> <p>TM03 8306 1007</p>
14	 <p>Make sure that the laser units are at the same height.</p> <p>TM03 8307 1007</p>

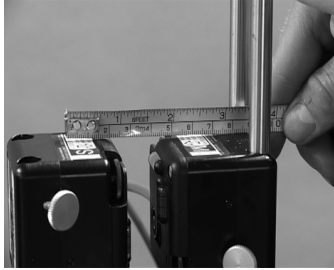
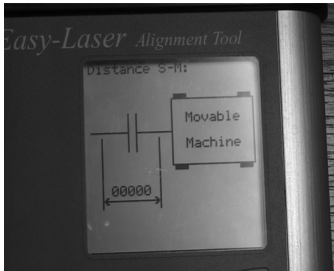
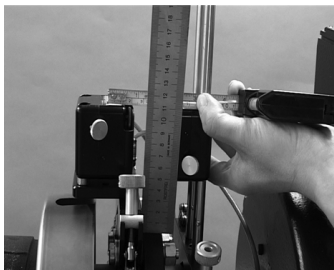
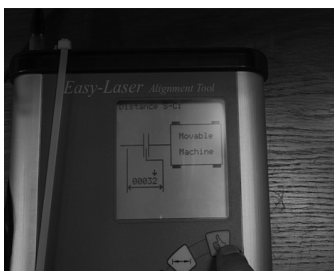
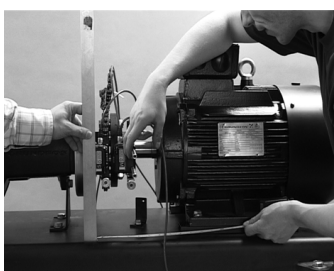
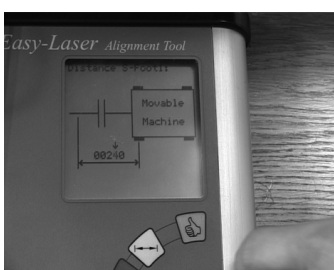
Step	Action
15	 <p>Measure the distance between the white lines on the laser units.</p> <p>TM03 8309 1007</p>
16	 <p>Enter the distance.</p> <p>TM03 8308 1007</p>
17	 <p>Measure the distance between the S unit and the centre of the gap between the couplings.</p> <p>TM03 8310 1007</p>
18	 <p>Enter the distance.</p> <p>TM03 8311 1007</p>
19	 <p>Measure the distance from the S unit to the first screw on the motor.</p> <p>TM03 8312 1007</p>
20	 <p>Enter the distance.</p> <p>TM03 8313 1007</p>

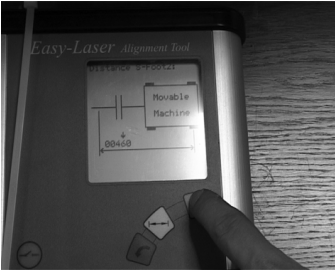
Step	Action
21	 <p>Measure the distance from the S unit to the rear screw on the motor.</p> <p>TM03 8314 1007</p>

22	 <p>The control box shows that the laser units must be turned to position 9 o'clock.</p> <p>TM03 8315 1007</p>
----	---

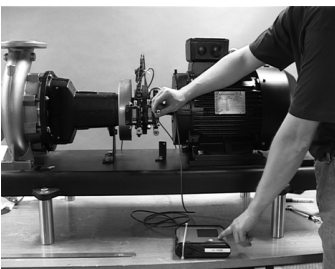
23	 <p>Turn the laser units to position 9 o'clock.</p> <p>TM03 8316 1007</p>
----	---

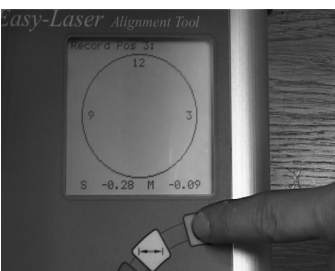
24	 <p>Confirm on the control box.</p> <p>TM03 8319 1007</p>
----	--

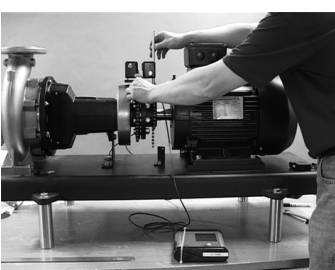
25	 <p>Turn the laser units to position 12 o'clock. Confirm on the control box.</p> <p>TM03 8317 1007</p>
----	---

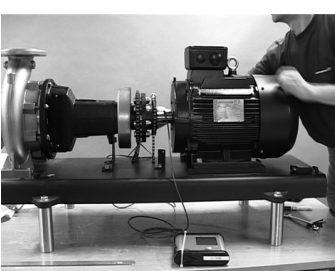
26	 <p>Turn the laser units to position 3 o'clock. Confirm on the control box.</p> <p>TM03 8318 1007</p>
----	--

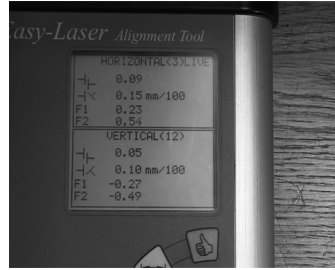
Step	Action
27	 <p>If the measured values are less than 0.1 mm, the alignment is complete. Go to step 32.</p> <p>TM03 8320 1007</p>

28	 <p>Adjust the position of the motor. Loosen the screws that hold the motor in place.</p> <p>TM03 8321 1007</p>
----	---

29	 <p>Insert shims with the required thickness.</p> <p>TM03 8322 1007</p>
----	--

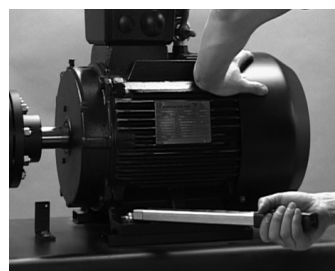
30	 <p>Tighten the screws to the correct torque again.</p> <p>TM03 8324 1007</p>
----	---

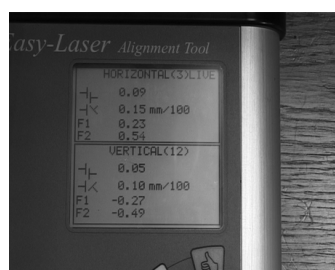
31	 <p>Repeat the alignment until the values are within the tolerances. Go to step 22.</p> <p>TM03 8320 1007</p>
----	---

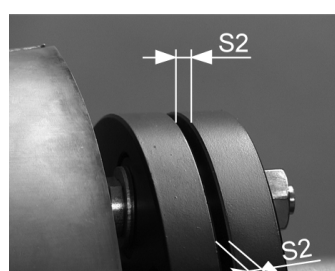
32	 <p>Check the gap S2. See the table <i>Air-gap width S2</i> on page 15.</p> <p>TM03 8325 1007</p>
----	---

Tightening torques

Description	Dimensions	Tightening torque [Nm]
Hexagon head screw	M6	10 ± 2
	M8	12 ± 2.4
	M10	23 ± 4.6
	M12	40 ± 8
	M16	80 ± 16
	M20	120 ± 24
	M24	120 ± 24

Air-gap width S2

Outside coupling diameter [mm]	Air-gap width S2 [mm]			
	Standard coupling		Spacer coupling	
	Nominal	Tolerance	Nominal	Tolerance
80	-	-	4	0/-1
95	-	-	4	0/-1
110	-	-	4	0/-1
125	4	0/-1	4	0/-1
140	4	0/-1	4	0/-1
160	4	0/-1	4	0/-1
200	4	0/-1	6	0/-1
225	4	0/-1	6	0/-1
250	4	0/-1	8	0/-1

Note

Measure S2 all the way around the coupling. The maximum permissible deviation between the largest and the smallest measurement is 0.2 mm.

If the coupling and motor are not supplied by Grundfos, make sure to follow the coupling manufacturer's instructions.



Warning

The coupling guard must always be fitted during operation.

7.4 Pipework

7.4.1 Piping

When installing the pipes, make sure that the pump housing is not stressed by the pipework.

The suction and discharge pipes must be of an adequate size, taking the pump inlet pressure into account.

Install the pipes so that air locks are avoided, especially on the suction side of the pump.

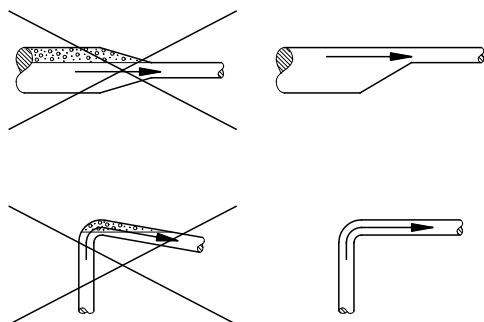

Fig. 13 Pipelines

TM00 2263 3393

Fit isolating valves on either side of the pump to avoid having to drain the system if the pump needs to be cleaned or repaired. Make sure the pipes are adequately supported as close to the pump as possible, both on the suction and the discharge side. The counter-flanges must lie true against the pump flanges without being stressed as stress would cause damage to the pump.

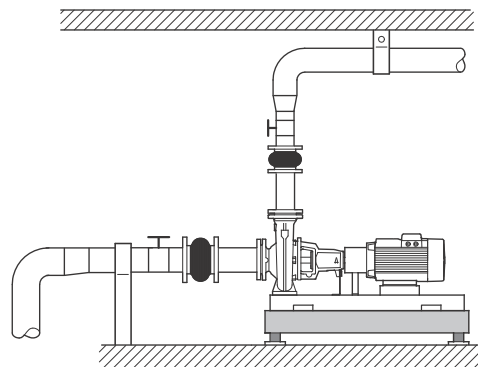

Fig. 14 Pipeline mounting

TM05 3488 1412

7.4.2 Bypass



Warning

The pump is not allowed to run against a closed valve as this will cause an increase in temperature/formation of steam in the pump which may cause damage to the pump.

If there is any danger of the pump running against a closed discharge valve, ensure a minimum liquid flow through the pump by connecting a bypass or drain to the discharge pipe. The minimum flow rate must be at least 10 % of the maximum flow rate. The flow rate and head are stated on the pump nameplate.

7.5 Vibration damping

7.5.1 Elimination of noise and vibrations

In order to achieve optimum operation and minimum noise and vibration, consider vibration damping of the pump. Generally, always consider this for pumps with motors of 11 kW and up. Vibration damping is mandatory for motors of 90 kW and up. Smaller motor sizes, however, may also cause undesirable noise and vibration.

Noise and vibration are generated by the revolutions of the motor and pump and by the flow in pipes and fittings. The effect on the environment is subjective and depends on correct installation and the state of the rest of the system.

Elimination of noise and vibrations is best achieved by means of a concrete foundation, vibration dampers and expansion joints. See fig. 14.

7.5.2 Vibration dampers

To prevent the transmission of vibrations to buildings, we recommend isolating the pump foundation from building parts by means of vibration dampers.

The selection of the right vibration damper requires the following data:

- forces transmitted through the damper
- motor speed, taking speed control, if any, into consideration
- required damping in % - suggested value is 70 %.

The selection of vibration damper differs from installation to installation. In certain cases, a wrong damper may increase the vibration level. Vibration dampers must therefore be sized by the supplier of the vibration dampers.

If you install the pump on a foundation with vibration dampers, always fit expansion joints on the pump flanges. This is important to prevent the pump from "hanging" in the flanges.

7.6 Expansion joints

Expansion joints provide these advantages:

- absorption of thermal expansion and contraction of pipework caused by variations in liquid temperature
- reduction of mechanical influences in connection with pressure surges in the pipework
- isolation of structure-borne noise in the pipework; this applies only to rubber bellows expansion joints.

Note Do not install expansion joints to make up for inaccuracies in the pipework, such as centre displacement or misalignment of flanges.

The expansion joints must be fitted at a minimum distance of 1 to 1 1/2 pipe diameters away from the pump on the suction and the discharge side. This prevents turbulence in the joints, thus ensuring optimum suction conditions and minimum pressure loss on the discharge side. At flow velocities greater than 5 m/s, we recommend fitting larger expansion joints matching the pipework.

Figures 15 and 16 show examples of rubber bellows expansion joints with or without limiting rods.



Fig. 15 Rubber bellows expansion joint with limiting rods

TM02 4979 1902



Fig. 16 Rubber bellows expansion joint without limiting rods

TM02 4981 1902

Expansion joints with limiting rods can be used to reduce the effects of the expansion/contraction forces on the pipework. We always recommend expansion joints with limiting rods for flanges larger than DN 100.

Anchor the pipes in such a way that they do not stress the expansion joints and the pump. Follow the supplier's instructions and pass them on to advisers or pipe installers.

Figure 17 shows an example of a metal bellows expansion joint with limiting rods.

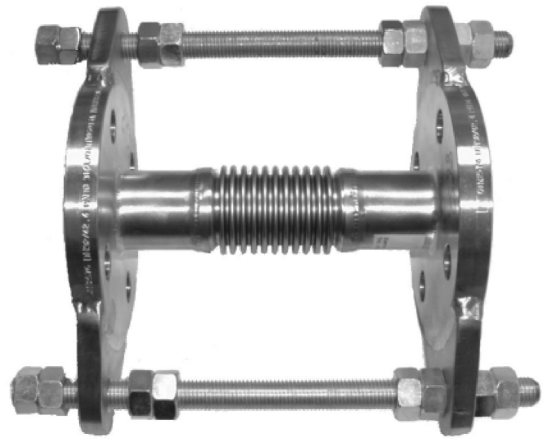

TM02 4980 1902

Fig. 17 Metal bellows expansion joint with limiting rods

Due to the risk of rupture of the rubber bellows, metal bellows expansion joints may be preferred at temperatures above +100 °C combined with high pressure.

7.7 Stuffing box piping

Pumps with stuffing box will always have a continuous leakage during normal operation. We recommend to connect a drainage pipe to the drain hole of the bearing bracket, pos. A, G1/2, to collect the leaking liquid.

For pumps with stuffing box, type SNF, and external barrier liquid, connect the drain pipe to the hole, pos. B, G1/8, before starting the pump. The outlet hole for the external flushing pipe, pos. C, is Ø10.

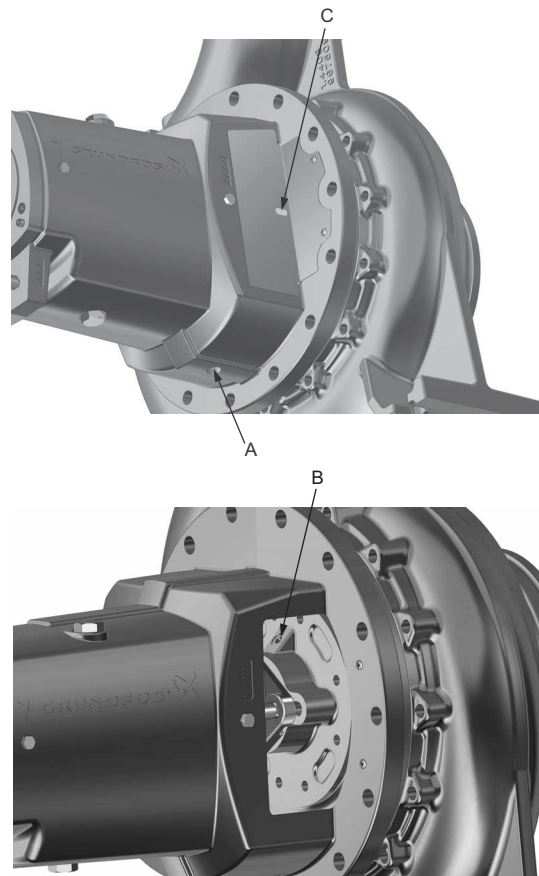

Fig. 18 Pipe connections for stuffing box operation

TM06 3413 0315 - TM06 3414 0315

7.8 Bearing bracket

7.8.1 Bearing bracket with grease lubrication

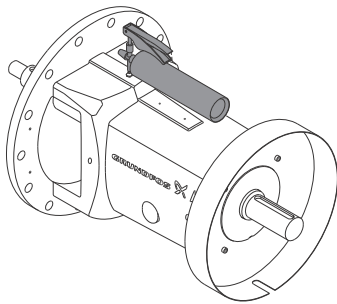

Fig. 19 Bearing bracket with grease nipples

Relubricate the bearings by means of a grease gun. See section [11.2.1 Grease-lubricated bearings](#) to get recommended re-lubricating intervals.

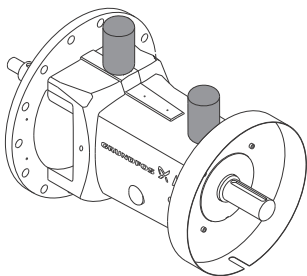

Fig. 20 Bearing bracket with automatic grease lubricators

The lubricators are supplied separately. Remove the grease nipples, fit the grease lubricators on top of the bearing bracket and set them to empty within 12 months according to the instructions supplied with the lubricators.

7.8.2 Bearing bracket with constant-level oiler

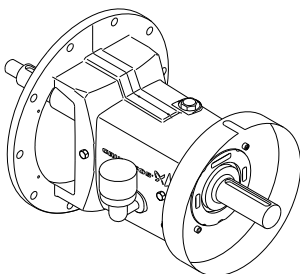

Fig. 21 Bearing bracket with constant-level oiler

Caution There is no oil in bearing bracket when it is delivered.

Note Fit the constant-level oiler on the bearing bracket before filling oil into the bearing bracket. See instructions on the label on the reservoir.

Filling of oil

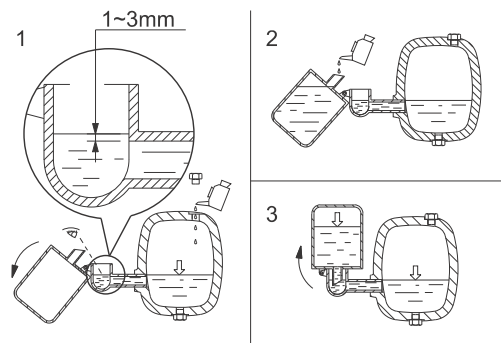

Fig. 22 Filling of oil

Step	Action
1	Remove the filling plug. Hinge down the constant-level oiler, and pour the oil through the filling hole until the oil reaches level in the connection elbow. See 1 in fig. 22.
2	Fill the reservoir of the constant-level oiler with oil, and snap it back into operating position. Now oil will be filled into the bearing bracket. Air bubbles can be seen in the reservoir during this process. Continue until the correct oil level is reached. See 2 in fig. 22.
3	When no bubbles appear in the reservoir, refill the reservoir, and snap it back into operating position. See 3 in fig. 22.
4	Fit the filling plug.

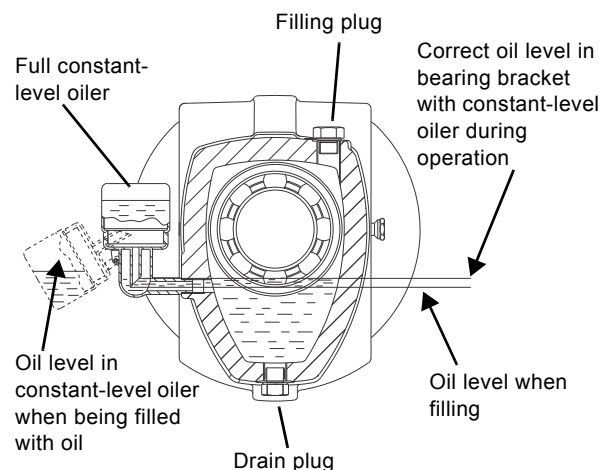

Fig. 23 Filling of oil

The oil level in the bearing bracket must always be as shown in fig. 23.

Caution Check the oil level regularly during operation, and add oil, if necessary. The oil level must always be visible in the sight glass.

Checking the oil level

The oil level in the bearing bracket will be correct as long as the function of the constant-level oiler is correct. To check the function of the constant-level oiler, slowly drain oil through the drain plug until the constant-level oiler starts to operate, i.e. until air bubbles can be seen in the reservoir.

7.9 Bearing monitoring

7.9.1 Vibration level

The vibration level gives an indication of the condition of the bearings.

Bearing brackets with constant-level oiler are prepared for vibration measurement by means of the shock pulse method (SPM). See fig. 24.

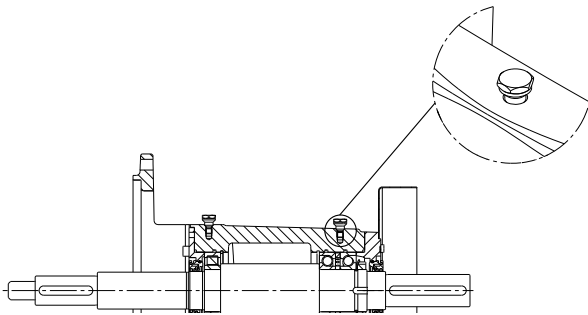

Fig. 24 Bearing bracket with SPM measuring points

TM04 4925 4309

Bearing brackets with automatic grease lubricators or grease nipples are prepared for retrofitting of SPM fittings. Holes are plugged from factory. See fig. 25.

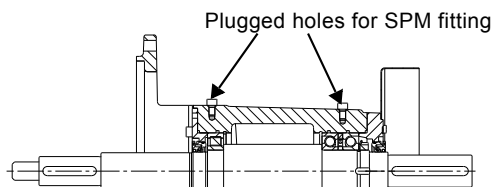

Fig. 25 Bearing bracket for retrofitting of SPM measuring equipment

TM06 3500 0415

7.9.2 Temperature

Bearing brackets with automatic grease lubricators, grease nipples or constant-level oiler have tappings for Pt100 sensors for monitoring the temperature of the bearings.

These sensors can be factory-fitted, but can also be retrofitted. A Grundfos sensor is available.

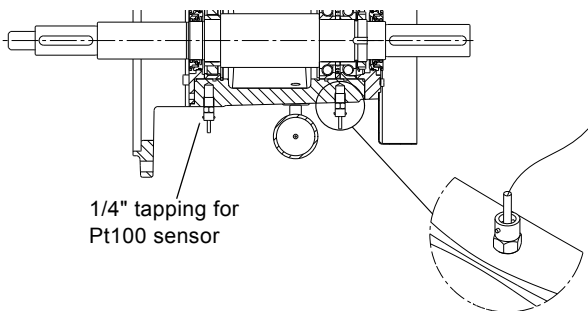

Fig. 26 Pt100 sensors fitted in bearing bracket

TM04 4925 4309

7.10 Pressure gauge and mano-vacuum gauge

To ensure continuous monitoring of the operation, we recommend installing a pressure gauge on the discharge side and a mano-vacuum gauge on the suction side. Open the pressure gauge tappings only for test purposes. The measuring range of the gauges must be 20 % above the maximum pump discharge pressure.

When measuring with pressure gauges on the pump flanges, it must be noted that a pressure gauge does not register dynamic pressure. On all NK and NKG pumps, the diameters of the suction and discharge flanges are different which results in different flow velocities at the two flanges. Consequently, the pressure gauge on the discharge flange will not show the pressure stated in the technical documentation, but a value which may be up to 1.5 bar or approx. 15 m lower.

7.11 Ammeter

To check the motor load, we recommend connecting an ammeter.

8. Flange forces and torques

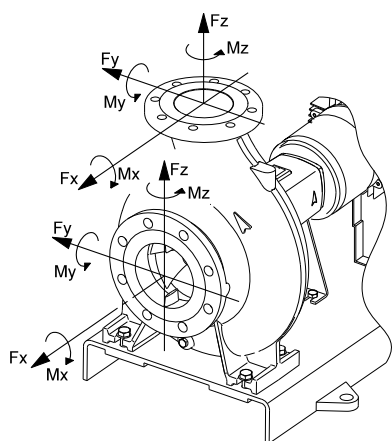

TM04 5621 3609

Fig. 27 Flange forces and torques

Grey cast iron	Diameter DN	Force [N]				Torque [Nm]					
		Fy	Fz	Fx	ΣF*	My	Mz	Mx	ΣM*		
Horizontal pump, z-axis, discharge port	32	298	368	315	578	263	298	385	560		
	40	350	438	385	683	315	368	455	665		
	50	473	578	525	910	350	403	490	718		
	65	595	735	648	1155	385	420	525	770		
	80	718	875	788	1383	403	455	560	823		
	100	945	1173	1050	1838	438	508	613	910		
	125	1120	1383	1243	2170	525	665	735	1068		
	150	1418	1750	1575	2748	613	718	875	1278		
	200	2600	2100	2095	4055	805	928	1138	1680		
	250	3340	2980	2700	5220	1260	1460	1780	2620		
Horizontal pump, x-axis, suction port	50	525	473	578	910	350	403	490	718		
	65	648	595	735	1155	385	420	525	770		
	80	788	718	875	1383	403	455	560	823		
	100	1050	945	1173	1838	438	508	613	910		
	125	1243	1120	1383	2170	525	665	735	1068		
	150	1575	1418	1750	2748	613	718	875	1278		
	200	2100	1890	2345	3658	805	928	1138	1680		
	250	2700	3340	2980	5220	1260	1460	1780	2620		
	300	3220	4000	3580	6260	1720	1980	2420	3560		
Stainless steel	Diameter DN	Force [N]				Torque [Nm]					
		Fy	Fz	Fx	ΣF*	My	Mz	Mx	ΣM*		
		32	595	735	630	1155	525	595	770	1120	
		40	700	875	770	1365	630	735	910	1330	
		50	945	1155	1050	1820	700	805	980	1435	
		Horizontal pump, z-axis, discharge port	65	1190	1470	1295	2310	770	840	1050	1540
		80	1435	1750	1575	2765	805	910	1120	1645	
		100	1890	2345	2100	3675	875	1015	1225	1820	
		125	2240	2765	2485	4340	1050	1330	1470	2135	
		150	2835	3500	3150	5495	1225	1435	1750	2555	
Horizontal pump, x-axis, suction port	50	1050	945	1155	1820	700	805	980	1435		
	65	1295	1190	1470	2310	770	840	1050	1540		
	80	1575	1435	1750	2765	805	910	1120	1645		
	100	2100	1890	2345	3675	875	1015	1225	1820		
	125	2485	2240	2765	4340	1050	1330	1470	2135		
	150	3150	2835	3500	5495	1225	1435	1750	2555		
	200	4200	3780	4690	7315	1610	1855	2275	3360		

* ΣF and ΣM are the vector sums of the forces and torques.

If not all loads reach the maximum permissible value, one of the values is allowed to exceed the normal limit. Contact Grundfos for further information.

9. Electrical connection

The electrical connection must be carried out by a qualified electrician in accordance with local regulations.



Warning

Before removing the terminal box cover and before removing/dismantling the pump, make sure that the power supply has been switched off and that it cannot be accidentally switched on again.

The pump must be connected to an external mains switch.

The operating voltage and frequency are stated on the nameplate. Make sure that the motor is suitable for the power supply of the installation site.

The electrical connection must be carried out as shown in the wiring diagram inside the terminal box cover.



Warning

Whenever powered equipment is used in explosive surroundings, the rules and regulations generally or specifically imposed by the relevant responsible authorities or trade organisations must be observed.

9.1 Motor protection

Three-phase motors must be connected to a motor-protective circuit breaker.

All three-phase Grundfos MG and MMG motors of 3 kW and up incorporate a thermistor. See the instructions in the motor terminal box.

Carry out the electrical connection as shown in the wiring diagram on the back side of the terminal box cover.



Warning

Before starting any repair work on motors incorporating a thermal switch or thermistors, make sure that the motor cannot restart automatically after cooling.

9.2 Frequency converter operation

All three-phase motors can be connected to a frequency converter.

Frequency converter operation will often expose the motor insulation system to a heavier load and cause the motor to be more noisy than usual due to eddy currents caused by voltage peaks.

A large motor driven via a frequency converter will be loaded by bearing currents.

Check these operating conditions if the pump is driven via a frequency converter:

Operating conditions	Action
2-, 4- and 6-pole motors, frame size 225 and larger	Check that one of the motor bearings is electrically isolated. Contact Grundfos.
Noise critical applications	Fit an output filter between the motor and the frequency converter; this reduces the voltage peaks and thus the noise.
Particularly noise critical applications	Fit a sinusoidal filter.
Cable length	Fit a cable that meets the specifications laid down by the frequency converter supplier. The length of the cable between motor and frequency converter affects the motor load.
Supply voltage up to 500 V	Check that the motor is suitable for frequency converter operation.
Supply voltage between 500 V and 690 V	Fit a sinusoidal filter between the motor and the frequency converter which reduces the voltage peaks and thus the noise, or check that the motor has reinforced insulation.
Supply voltage of 690 V and higher	Fit a sinusoidal filter and check that the motor has reinforced insulation.

10. Commissioning and startup

Note

Do not start the pump until it has been filled with liquid and vented.

10.1 General information



Warning

When pumping drinking water, the pump must be flushed through with clean water before startup in order to remove any foreign matters such as preservatives, test liquid or grease.

10.1.1 Pumps with stuffing box

In the case of pumps with stuffing box, check that the stuffing box gland is correctly fitted. It must be possible to turn the pump shaft manually. If the pump has been inactive for a long period, turn it manually to make sure it has not got stuck. Loosen the stuffing box or remove the packing.

10.2 Commissioning

10.2.1 Flushing the pipe system

The pump is not designed to pump liquids containing solid particles such as pipe debris and welding slag. Before starting up the pump, the pipe system must be thoroughly cleaned, flushed and filled with clean water.

Caution

The warranty does not cover any damage caused by flushing the pipe system by means of the pump.

10.3 Priming

Closed systems or open systems where the liquid level is above the pump inlet

1. Close the discharge isolating valve and slowly open the isolating valve in the suction pipe. Both the pump and the suction pipe must be completely filled with liquid.
2. Loosen the priming plug in order to vent the pump. Once liquid runs out, tighten the priming plug.

Warning

Pay attention to the orientation of the priming hole to ensure that the escaping water does not cause personal injury or damage to the motor or other components.



In hot-liquid installations, pay special attention to the risk of personal injury caused by scalding hot liquid.

In cold-liquid installations, pay special attention to the risk of personal injury caused by cold liquid.

Suction operation with non-return valve

The suction pipe and the pump must be filled with liquid and vented before the pump is started.

1. Close the discharge isolating valve and slowly open the isolating valve in the suction pipe.
2. Remove the priming plug, M.
3. Pour liquid through the hole until the suction pipe and the pump are completely filled with liquid.
4. Fit the priming plug, M.

The suction pipe may be filled and vented via the priming plug. See fig. 28. Alternatively a priming device with funnel can be installed before the pump.

Open systems where the liquid level is below the pump inlet

1. If an isolating valve is fitted on the suction side of the pump, the valve must be fully open.
2. Close the discharge isolating valve and tighten the priming and drain plugs.
3. Connect a manual venting pump instead of a priming device with funnel.
4. Install a slide valve between the venting pump and the centrifugal pump in order to protect the venting pump against excessive pressure.
5. Once the slide valve at the manual venting pump has been opened, vent the suction pipe using short, rapid pump strokes until the liquid runs out on the discharge side.
6. Close the valve at the venting pump.

E Drain plug
M Priming plug

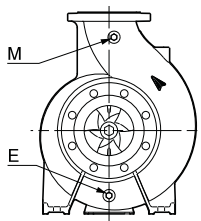

TM03 3935 1206

Fig. 28 Drain and priming plug

10.4 Checking the direction of rotation



Warning

The pump must be filled with liquid when checking the direction of rotation.

The correct direction of rotation is shown by arrows on the pump housing. Seen from the pump end, the direction of rotation must be counter-clockwise. See fig. 28.

10.5 Startup

Before starting the pump, completely open the isolating valve on the suction side of the pump and leave the isolating valve on the discharge side almost closed.

Start the pump.

Vent the pump during startup by loosening the air vent screw in the pump head/cover until a steady stream of liquid runs out of the vent hole.

Warning

Pay attention to the orientation of the vent hole to ensure that the escaping water does not cause personal injury or damage to the motor or other components.



In hot-liquid installations, pay special attention to the risk of personal injury caused by scalding hot liquid.

In cold-liquid installations, pay special attention to the risk of personal injury caused by cold liquid.

When the pipework has been filled with liquid, slowly open the isolating valve on the discharge side until it is completely open.

Caution

If the pump is fitted with a motor with an output selected on the basis of a specific maximum flow rate, the motor may be overloaded if the differential pressure is lower than anticipated.

Check for overload by measuring the motor current consumption and comparing the value with the rated current stated on the motor nameplate. In case of overload, throttle the valve on the discharge side until the motor is no longer overloaded.

Always measure the motor current consumption during startup.

Note

At the moment of start, the input current of the pump motor is up to six times higher than the full-load current stated on the motor nameplate.

10.6 Shaft seal run-in period

The seal faces are lubricated by the pumped liquid, meaning that there may be a certain amount of leakage from the shaft seal. When the pump is started for the first time, or when a new shaft seal is installed, a certain run-in period is required before the leakage is reduced to an acceptable level. The time required for this depends on the operating conditions, i.e. every time the operating conditions change, a new run-in period will be started. Under normal conditions, the leaking liquid will evaporate. As a result, no leakage will be detected.

Liquids such as kerosene will not evaporate, and drops will be visible, but this is not a shaft seal failure.

Mechanical shaft seals

Mechanical shaft seals are precision components. If the mechanical shaft seal of a recently installed pump fails, this will normally happen within the first few hours of operation. The main cause of such failures is improper installation of the shaft seal or the pipe for barrier liquid and/or mishandling of the pump during installation.

Stuffing box

The stuffing box gland must not be too tight during startup in order to let sufficient liquid lubricate the shaft and the packing rings. Once the stuffing box housing and the stuffing box gland have reached approximately the same temperature as the pump parts, the running-in of the stuffing box gland is complete. If the stuffing box leaks too much, retighten the gland slightly and evenly while the pump is running. To ensure continuous lubrication, a few drops should always drop from the stuffing box to protect the packing rings or shaft sleeve. We recommend 40 to 60 drops/minute.

10.7 Motor start/stop

Frame size	Max. number of motor starts per hour		
	Number of poles		
	2	4	6
56-71	100	250	350
80-100	60	140	160
112-132	30	60	80
160-180	15	30	50
200-225	8	15	30
250-315	4	8	12

10.8 Reference readings of monitoring equipment

We recommend taking initial readings of these parameters:

- vibration level - use SPM measuring points
- bearing temperature - if sensors have been fitted
- inlet and outlet pressure - use pressure gauges.

The readings can be used as reference in case of abnormal operation.

11. Maintenance



Warning

Before starting work on the product, switch off the power supply. Make sure that the power supply cannot be accidentally switched on.

11.1 Pump

The pump is maintenance-free.

11.1.1 Mechanical shaft seals

Mechanical shaft seals are maintenance-free, working almost without any leakages. If any considerable and increasing seepage occurs, the mechanical shaft seal must be checked immediately. If the sliding surfaces are damaged, the entire shaft seal must be replaced. Mechanical shaft seals must be treated with the greatest care.

11.1.2 Stuffing box

If the stuffing box leaks too much and cannot be further tightened, the stuffing box must be repacked. After removal, clean and check the shaft sleeve, chamber and stuffing box gland. For further information, see the service instructions for NK.

11.1.3 Replacement of packing rings

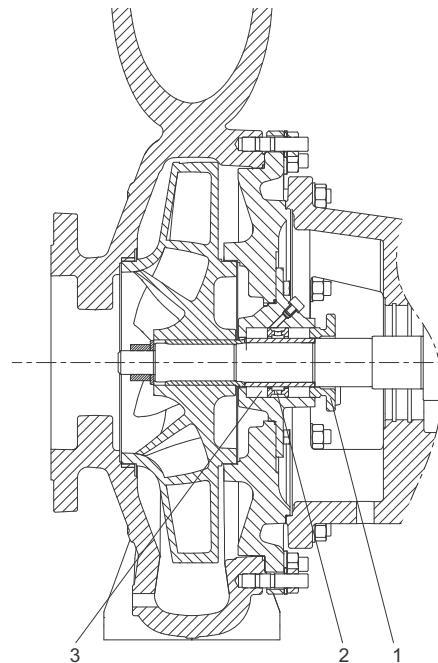

Fig. 29 Sectional view of a stuffing box

Pos.	Description
1	Stuffing box gland
2	Packing ring
3	Distribution ring

Follow these steps when replacing the packing rings:

1. Loosen stuffing box gland and remove it.
2. Remove old packing ring, distribution ring, if any, and packing rings behind the distribution ring, using a packing ring hook.
3. Insert two new packing rings one at a time. Push them firmly into position, staggering the joints 120 degrees.
4. Insert distribution ring, if any.
5. For D24/D32, insert one, and for D42/D48/D60, insert two more packing rings, staggering the joints 120 degrees. If no distribution ring is used, two extra packing rings will be required.
6. Reinstall stuffing box gland.

Starting the pump with new packing rings

Packing rings require lubrication. Therefore, the stuffing box must always be allowed to leak 40 to 60 drops per minute. Never overtighten the stuffing box gland.

For suction lift applications, it can be necessary to slightly overtighten the gland while starting the pump to avoid air from entering the pump. Air in the pump in this situation will result in the pump being unable to draw the liquid to the pump.

Loosen the gland immediately when the pump delivers liquid allowing a leakage of 40 to 60 drops per minute. Readjust after a few hours of operation if leakage increases.

11.1.4 Shaft sleeve replacement

The shaft sleeve can be worn out as the sleeve life depends on the application. When the leakage is too high even with new packing rings in combination with a slight overtightening, the shaft sleeve needs to be replaced.

11.2 Lubrication of bearings in bearing bracket

11.2.1 Grease-lubricated bearings

Pump with greased-for-life bearings

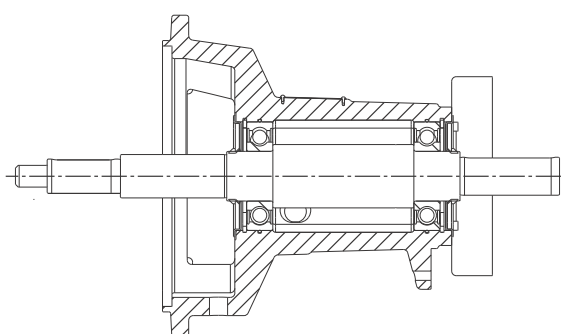

Fig. 30 Bearing bracket with closed, greased-for-life bearings

The bearing bracket with closed, greased-for-life bearings is maintenance-free. Under optimum operating conditions, the bearing life will be approx. 17,500 operating hours. After that period, it is advisable to replace the bearings. See section [13.1 Service kits](#).

Note

To check the bearings, regularly listen to them by means of a solid rod. There are no SPM measuring points for this type of bearing bracket.

Pump with lubrication nipples or automatic grease lubricators

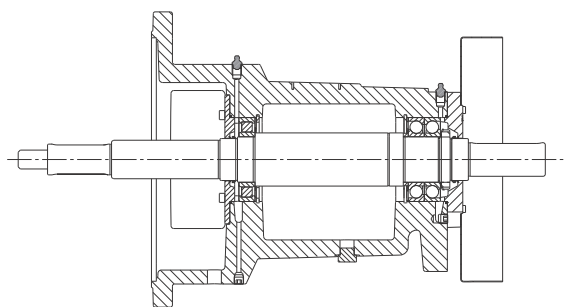

Fig. 31 Bearing bracket with open roller bearing and double angular contact bearing lubricated via grease nipples

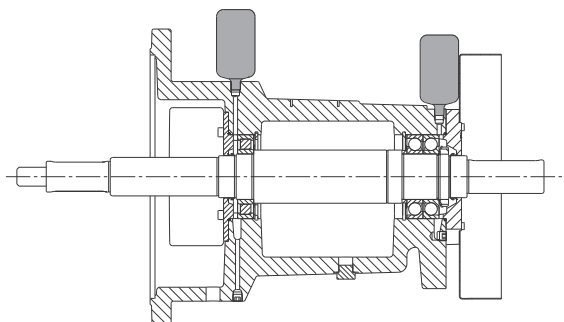

Fig. 32 Bearing bracket with open roller bearing and double angular contact bearing lubricated via automatic grease lubricators

If the pump has grease nipples or automatic grease lubricators, the grease in the bearings must be renewed during the whole life time.

Under optimum operating conditions, the bearing life will be approx. 100,000 operating hours. After that period, it is advisable to replace the bearings. See section [13.1 Service kits](#). New bearings must be filled with grease according to Grundfos specifications. Clean up all the used grease in the bearing bracket before replacing the new bearing.

Automatic grease lubricators

Replace lubricators every 12 months. When replacing the lubricators, follow this procedure:

1. Remove the main drain plug, see [fig. 33](#), in the bottom of the bearing bracket for one hour during operation to remove old and excess grease.
2. Fit the new lubricators on top of the bearing bracket and set them to empty within 12 months according to the instruction supplied with the lubricators.
3. Refit the main drain plug in the bottom of the bearing bracket.

Grundfos recommends SKF SYSTEM 24 lubricators, type LAGD 125/HP2 or LAGD 60/HP2.

Quantity	Product number
2 x LAGD 125/HP2	96887371
2 x LAGD 60/HP2	97776374

Relubrication via grease nipples

Grundfos recommends the following relubricating intervals and grease quantities:

Diameter of shaft [mm]	Relubricating interval [operating hours]	Grease quantity [g]	
		Roller bearing	Angular contact bearing
24	7500	11	15
32	4500	13	20
42	4500	22	30
48	3500	27	38
60	3500	30	41

The relubricating interval is an estimated value, valid for an operating temperature up to 70 °C. We recommend to halve the intervals for every 15 °C increase in operating temperature above 70 °C.

Caution

How to renew grease

Follow this procedure to renew grease:

1. Place a suitable container under the bearing bracket to collect used grease.
2. Remove the grease drain plugs. See fig. 33.
3. Fill the bearing bracket with the recommended quantity of grease by means of a grease gun.
4. Refit the drain plugs.

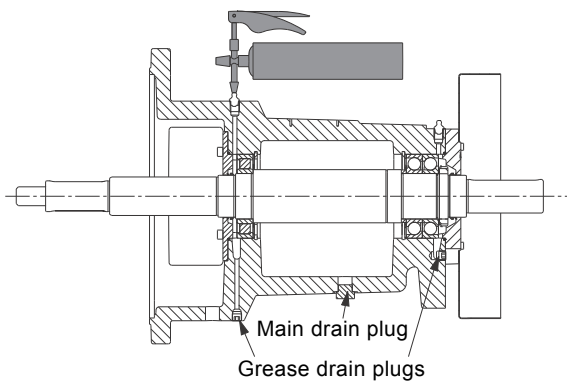

Fig. 33 Renewing the grease

TM06 1829 3014

Grundfos recommends SKF LGHP2 grease for relubrication. See the table below.

Basic characteristics	
Code, DIN 51825	K2N-40
Consistency class, NLGI	2-3
Thickener	Polyurea (di-urea)
Base oil	Mineral
Operating temperature	-40 - +150 °C, -40 - +302 °F
Dropping point, ISO 2176	240 °C, 464 °F
Density, DIN 5175	At 20 °C, 68 °F: 0.85 - 0.95 g/cm ³
Base oil viscosity	
40 °C, 104 °F	96 mm ² /s
100 °C, 212 °F	10.5 mm ² /s

Note If there is visible grease leakage, we advise you to open the bearing bracket cover and replace the V ring. See section 13.1 *Service kits*.

Caution If the pump has been stored or out of operation for more than six months, we recommend you to replace the grease before it is put into operation.

Caution In case of ingress of contamination, more frequent relubrication than indicated by the relubricating interval will reduce the negative effects of foreign particles. This will reduce the damaging effects caused by overrolling the particles. Liquid contaminants, such as water or process liquids, also call for shorter relubricating intervals. In case of severe contamination, consider continuous relubrication.

Caution Never mix greases with different thickeners, such as a lithium-based grease with a sodium-based grease, before checking with the suppliers.

Caution Never mix a mineral oil with a synthetic oil. Some lubricants are compatible, but assessing the compatibility of two lubricants can be difficult. As a general rule, always relubricate a bearing with the same lubricant as was used originally.

11.2.2 Oil-lubricated bearings

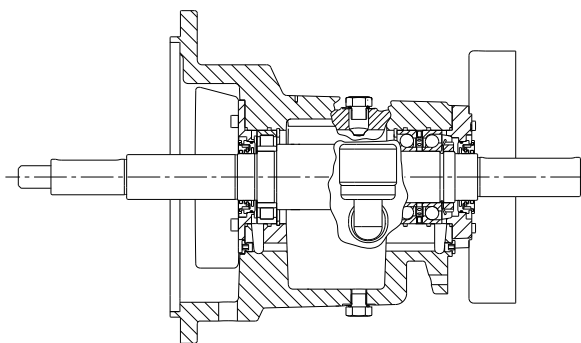

Fig. 34 Bearing bracket with oil-lubricated roller and double angular contact bearings

Under optimum operating conditions, the life of the roller and double angular contact bearings will be approx. 100,000 operating hours. After that period, it is advisable to replace the bearings. See section [13.1 Service kits](#).

Note To monitor the bearing condition, regularly measure vibration levels using the SPM measuring points on the bearing bracket. See section [7.9.1 Vibration level](#).

The bearings are lubricated with mineral oil. Intervals for oil change as well as the required quantities are specified below.

Bearing temperature	Initial oil change	Subsequent oil changes
Up to 70 °C	After 400 hours	Every 4400 hours
70-90 °C		Every 2200 hours

Bearing type	Diameter of coupling shaft [mm]	Approximate oil quantity [ml]
Roller and angular contact bearings	42	850
	48	1700
	60	1350

Changing of oil

Step	Action
1	Place a suitable container under the bearing bracket to collect used oil.
2	Remove the vent/filling plug and the drain plug.
3	After drainage of the bearing bracket, fit the drain plug, and fill the bearing bracket with new oil. See section 7.8.2 Bearing bracket with constant-level oiler .

Note Check the oil level regularly during operation, and add oil, if necessary. The level must always be visible in the sight glass.

Basic characteristics Shell Omala 68	Test method	
Viscosity grade	ISO	68
AGMA EP Gear Oil Grade		68
Old AGMA Grade		2 EP
Viscosity:		
At 40 °C, 104 °F	D 445	68 mm ² /s
At 100 °C, 212 °F	D 445	8.8 mm ² /s
Flash point, COC, °F	D 92	405
Pour point, °F	D 97	-15

11.3 Monitoring equipment

It is advisable to take weekly readings of these parameters:

- vibration level - use SPM measuring points
- bearing temperature - if sensors have been fitted
- inlet and outlet pressure - use pressure gauges.

Alternatively, follow the maintenance plan laid out for your application.

11.4 Motor

Check the motor at regular intervals. It is important to keep the motor clean in order to ensure adequate ventilation. If the pump is installed in a dusty environment, it must be cleaned and checked regularly.

11.4.1 Lubrication

Motors up to and including frame size 132 have maintenance-free, greased-for-life bearings.

Motors of frame sizes larger than 132 must be greased according to the indications on the motor nameplate. Grease spills from the motor may occur.

Grease specifications: See section [11.4.2 Bearing grease](#).

11.4.2 Bearing grease

Lithium-based grease according to the following specifications must be used:

- NLGI class 2 or 3
- viscosity of basic oil: 70-150 cSt at +40 °C
- temperature range: -30 - +140 °C during continuous operation.

12. Periods of inactivity and frost protection

Pumps which are not being used during periods of frost must be drained to avoid damage.

Drain the pump by removing the drain plug. See fig. [28](#).

Do not tighten the priming plug or replace the drain plug until the pump is to be used again.

Warning



Care must be taken to ensure that the escaping liquid does not cause personal injury or damage to the motor or other components.

In hot-liquid installations, pay special attention to the risk of personal injury caused by scalding hot liquid.

In cold-liquid installations, pay special attention to the risk of personal injury caused by cold liquid.

If the pump is to be drained prior to a long period of inactivity, inject a few drops of silicone oil on the shaft at the bearing bracket. This will prevent the shaft seal faces from seizing up.

13. Service



Warning

If a pump has been used for a liquid which is injurious to health or toxic, the pump will be classified as contaminated.

If Grundfos is requested to service such a pump, Grundfos must be contacted with details about the pumped liquid, etc. before the pump is returned for service. Otherwise Grundfos can refuse to accept the pump for service.

Possible costs of returning the pump are paid by the customer.

13.1 Service kits

Service kits for NK, NKG, see Grundfos Product Center or Service Kit Catalogue.

14. Technical data

14.1 Electrical data

See the motor nameplate.

14.2 Sound pressure level

See table on page 29.

14.3 Belt drive

If the unit is belt-driven, the following data must not be exceeded:

Max. motor power [kW] for shaft end					
Speed n [min ⁻¹]	Ø24	Ø32	Ø42	Ø48	Ø60
1000	4	7	11	18	22
1500	5	10	25	32	38
2000	6	14	25	-	-
2500	7	17.5	-	-	-
3000	10	20	-	-	-

For higher power outputs, mount an intermediate shaft with pedestal bearings.

14.4 Operation with combustion engine

Warning

When operating with petrol or diesel engines, the engine manufacturer's installation and operating instructions must be strictly observed. Particularly the direction of rotation is very important. Viewed from the drive shaft end, the pump rotates to the right, clockwise. Viewed from the drive shaft end, the motor must therefore rotate to the left, counter-clockwise. The correct direction of rotation is indicated by the arrow on the pump housing.

If the engine is installed in a closed area, the combustion air data as well as data for exhaust gases must be particularly noted.

When draining the tank, make sure to have containers of adequate size ready for this purpose.



15. Fault finding



Warning

Before removing the terminal box cover and before removing/dismantling the pump, make sure that the power supply has been switched off and that it cannot be accidentally switched on again.

Fault	Cause	Remedy
1. Pump delivers no or too little liquid.	a) Wrong electrical connection, for instance two phases.	Check the electrical connection and remedy, if necessary.
	b) Wrong direction of rotation.	Interchange two phases of the power supply.
	c) Air in suction pipe.	Vent and fill the suction pipe and pump.
	d) Counter-pressure too high.	Set the duty point in accordance with the data sheet. Check the system for impurities.
	e) Inlet pressure too low.	Increase the liquid level on the suction side. Open the isolating valve in the suction pipe. Make sure that all the conditions in section 7.4 Pipework are complied with.
	f) Suction pipe or impeller blocked by impurities.	Clean the suction pipe or pump.
	g) Pump draws in air due to defective seal.	Check the pipeline seals, pump housing gaskets and shaft seals, and replace, if necessary.
	h) Pump draws in air due to low liquid level.	Increase the liquid level on the suction side and keep it as constant as possible.
2. Motor-protective circuit breaker has tripped because the motor is overloaded.	a) Pump blocked by impurities.	Clean the pump.
	b) Pump running above rated duty point.	Set the duty point in accordance with the data sheet.
	c) Density or viscosity of liquid higher than specified when ordering.	If less flow is sufficient, reduce the flow on the discharge side. Or fit a more powerful motor.
	d) Motor-protective circuit breaker overload setting incorrect.	Check the setting of the motor-protective circuit breaker and replace, if necessary.
	e) Motor runs on two phases.	Check the electrical connection. Replace the fuse, if defective.
3. Pump makes too much noise. Pump runs unevenly and vibrates.	a) Inlet pressure too low, i.e. pump cavitates.	Increase the liquid level on the suction side. Open the isolating valve in the suction pipe. Make sure that all the conditions in section 7.4 Pipework are complied with.
	b) Air in suction pipe or pump.	Vent and fill the suction pipe or pump.
	c) Counter-pressure lower than specified.	Set the duty point in accordance with the data sheet.
	d) Pump draws in air due to low liquid level.	Increase the liquid level on the suction side and keep it as constant as possible.
	e) Impeller out of balance or clogged impeller blades.	Clean and check the impeller.
	f) Inner parts worn.	Replace the defective parts.
	g) Pump stressed by pipework thus causing starting noise.	Mount the pump so that it is not stressed. Support the pipes.
	h) Defective bearings.	Replace the bearings.
	i) Defective motor fan.	Replace the fan.
	j) Defective coupling.	Replace the coupling. Align the coupling. See section 7.3.2 How to align the unit .
	k) Foreign bodies in pump.	Clean the pump.
l) Frequency converter operation	See section 9.2 Frequency converter operation .	
4. Leaking pump, connections, shaft seal or stuffing box.	a) Pump stressed by pipework thus causing leaks in pump housing or connections.	Mount the pump so that it is not stressed. Support the pipes.
	b) Pump housing gaskets and gaskets at connections defective.	Replace pump housing gaskets or gaskets at connections.
	c) Mechanical shaft seal dirty or stuck together.	Check and clean the mechanical shaft seal.
	d) Mechanical shaft seal defective.	Replace the mechanical shaft seal.
	e) Stuffing box defective.	Retighten the stuffing box. Repair or replace the stuffing box.
	f) Shaft surface or shaft sleeve defective.	Replace the shaft or the shaft sleeve. Replace the packing rings in the stuffing box.

Fault	Cause	Remedy
5. Too high temperature in pump or motor.	a) Air in suction pipe or pump.	Vent the suction pipe or the pump and replenish.
	b) Inlet pressure too low.	Increase the liquid level on the suction side. Open the isolating valve in the suction pipe. Make sure that all the conditions in section 7.4 Pipework are complied with.
	c) Bearings lubricated with too little, too much or unsuitable lubricant.	Replenish, reduce or replace the lubricant.
	d) Pump with bearing seat stressed by pipework.	Mount the pump so that it is not stressed. Support the pipes. Check the alignment of the coupling. See section 7.3.2 How to align the unit .
	e) Axial pressure too high.	Check the relief holes of the impeller and the lock rings on the suction side.
	f) Motor-protective circuit breaker defective or setting incorrect.	Check the setting of the motor-protective circuit breaker and replace, if necessary.
	g) Motor overloaded.	Reduce the flow rate.
6. Oil leaking from bearing bracket.	a) Bearing bracket has been filled with too much oil through the filling hole, resulting in an oil level above the bottom of the shaft.	Drain off oil until the constant-level oiler starts to operate, i.e. when air bubbles can be seen in the reservoir.
	b) Oil seals defective.	Replace the oil seals.
7. Oil leaking from reservoir.	a) Threads on reservoir damaged.	Replace the reservoir.

16. Disposal

This product or parts of it must be disposed of in an environmentally sound way:

1. Use the public or private waste collection service.
2. If this is not possible, contact the nearest Grundfos company or service workshop.

Subject to alterations.

Appendix

Sound pressure levels

The data in this table applies for pump including motor, (MG, MMG, Siemens and TECO motors).

The values stated are maximum sound pressure levels. Tolerances are according to ISO 4871.

50 Hz

2-pole: $n = 2900 \text{ min}^{-1}$

4-pole: $n = 1450 \text{ min}^{-1}$

6-pole: $n = 970 \text{ min}^{-1}$

Motor [kW]	Maximum sound pressure level [dB(A)] - ISO 3743		
	Three-phase motors		
	2-pole	4-pole	6-pole
0.25	56	41	-
0.37	56	45	-
0.55	57	42	40
0.75	56	42	43
1.1	59	50	43
1.5	58	50	47
2.2	60	52	52
3	59	52	63
4	63	54	63
5.5	63	57	63
7.5	60	58	66
11	60	60	66
15	60	60	66
18.5	60	63	66
22	66	63	66
30	71	65	59
37	71	66	60
45	71	66	58
55	71	67	58
75	73	70	61
90	73	70	61
110	76	70	61
132	76	70	61
160	76	70	65
200	76	70	-
250	82	73	-
315	82	73	-
355	77	75	-
400	-	75	-

60 Hz

2-pole: $n = 3500 \text{ min}^{-1}$

4-pole: $n = 1750 \text{ min}^{-1}$

6-pole: $n = 1170 \text{ min}^{-1}$

Motor [kW]	Maximum sound pressure level [dB(A)] - ISO 3743		
	Three-phase motor		
	2-pole	4-pole	6-pole
0.25	-	-	-
0.37	-	-	-
0.55	-	-	-
0.75	-	-	-
1.1	64	51	43
1.5	64	52	47
2.2	65	55	52
3	54	57	63
4	68	56	63
5.5	68	62	63
7.5	73	62	66
11	70	66	66
15	70	66	66
18.5	70	63	66
22	70	63	66
30	71	65	62
37	71	65	63
45	75	65	62
55	75	68	62
75	77	71	66
90	77	71	66
110	81	75	66
132	81	75	66
160	81	75	69
200	81	75	-
280	86	-	-
288	-	77	-
353	86	-	-
362	-	77	-
398	81	-	-
408	-	79	-
460	-	79	-

Argentina

Bombas GRUNDFOS de Argentina S.A.
Ruta Panamericana km. 37.500 Centro
Industrial Garin
1619 Garin Pcia. de B.A.
Phone: +54-3327 414 444
Telefax: +54-3327 45 3190

Australia

GRUNDFOS Pumps Pty. Ltd.
P.O. Box 2040
Regency Park
South Australia 5942
Phone: +61-8-8461-4611
Telefax: +61-8-8340 0155

Austria

GRUNDFOS Pumpen Vertrieb Ges.m.b.H.
Grundfosstraße 2
A-5082 Grödig/Salzburg
Tel.: +43-6246-883-0
Telefax: +43-6246-883-30

Belgium

N.V. GRUNDFOS Bellux S.A.
Boomssesteenweg 81-83
B-2630 Aartselaar
Tél.: +32-3-870 7300
Télécopie: +32-3-870 7301

Belarus

Представительство ГРУНДФОС в
Минске
220125, Минск
ул. Шафарьянская, 11, оф. 56, БЦ
«Порт»
Тел.: +7 (375 17) 286 39 72/73
Факс: +7 (375 17) 286 39 71
E-mail: minska@grundfos.com

Bosna and Herzegovina

GRUNDFOS Sarajevo
Zmaja od Bosne 7-7A,
BH-71000 Sarajevo
Phone: +387 33 592 480
Telefax: +387 33 590 465
www.ba.grundfos.com
e-mail: grundfos@bih.net.ba

Brazil

BOMBAS GRUNDFOS DO BRASIL
Av. Humberto de Alencar Castelo Branco,
630
CEP 09850 - 300
São Bernardo do Campo - SP
Phone: +55-11 4393 5533
Telefax: +55-11 4343 5015

Bulgaria

Grundfos Bulgaria EOOD
Slatina District
Iztocna Tangenta street no. 100
BG - 1592 Sofia
Tel. +359 2 49 22 200
Fax. +359 2 49 22 201
email: bulgaria@grundfos.bg

Canada

GRUNDFOS Canada Inc.
2941 Brighton Road
Oakville, Ontario
L6H 6C9
Phone: +1-905 829 9533
Telefax: +1-905 829 9512

China

GRUNDFOS Pumps (Shanghai) Co. Ltd.
10F The Hub, No. 33 Suhong Road
Minhang District
Shanghai 201106
PRC
Phone: +86 21 612 252 22
Telefax: +86 21 612 253 33

Croatia

GRUNDFOS CROATIA d.o.o.
Buzinski prilaz 38, Buzin
HR-10010 Zagreb
Phone: +385 1 6595 400
Telefax: +385 1 6595 499
www.hr.grundfos.com

Czech Republic

GRUNDFOS s.r.o.
Čajkovského 21
779 00 Olomouc
Phone: +420-585-716 111
Telefax: +420-585-716 299

Denmark

GRUNDFOS DK A/S
Martin Bachs Vej 3
DK-8850 Bjerringbro
Tlf.: +45-87 50 50 50
Telefax: +45-87 50 51 51
E-mail: info_GDK@grundfos.com
www.grundfos.com/DK

Estonia

GRUNDFOS Pumps Eesti OÜ
Peterburi tee 92G
11415 Tallinn
Tel: + 372 606 1690
Fax: + 372 606 1691

Finland

OY GRUNDFOS Pumput AB
Trukkikuja 1
FI-01360 Vantaa
Phone: +358-(0) 207 889 500
Telefax: +358-(0) 207 889 550

France

Pompes GRUNDFOS Distribution S.A.
Parc d'Activités de Chesnes
57, rue de Malacombes
F-38290 St. Quentin Fallavier (Lyon)
Tél.: +33-4 74 82 15 15
Télécopie: +33-4 74 94 10 51

Germany

GRUNDFOS GMBH
Schlüterstr. 33
40699 Erkrath
Tel.: +49-(0) 211 929 69-0
Telefax: +49-(0) 211 929 69-3799
e-mail: infoservice@grundfos.de
Service in Deutschland:
e-mail: kundendienst@grundfos.de

Greece

GRUNDFOS Hellas A.E.B.E.
20th km. Athinon-Markopoulou Av.
P.O. Box 71
GR-19002 Peania
Phone: +0030-210-66 83 400
Telefax: +0030-210-66 46 273

Hong Kong

GRUNDFOS Pumps (Hong Kong) Ltd.
Unit 1, Ground floor
Siu Wai Industrial Centre
29-33 Wing Hong Street &
68 King Lam Street, Cheung Sha Wan
Kowloon
Phone: +852-27861706 / 27861741
Telefax: +852-27858664

Hungary

GRUNDFOS Hungária Kft.
Park u. 8
H-2045 Törökbálint,
Phone: +36-23 511 110
Telefax: +36-23 511 111

India

GRUNDFOS Pumps India Private Limited
118 Old Mahabalipuram Road
Thoraiakkam
Chennai 600 096
Phone: +91-44 2496 6800

Indonesia

PT. GRUNDFOS POMPA
Graha Intirub Lt. 2 & 3
Jln. Cililitan Besar No.454. Makassar,
Jakarta Timur
ID-Jakarta 13650
Phone: +62 21-469-51900
Telefax: +62 21-460 6910 / 460 6901

Ireland

GRUNDFOS (Ireland) Ltd.
Unit A, Merrywell Business Park
Ballymount Road Lower
Dublin 12
Phone: +353-1-4089 800
Telefax: +353-1-4089 830

Italy

GRUNDFOS Pompe Italia S.r.l.
Via Gran Sasso 4
I-20060 Truccazzano (Milano)
Tel.: +39-02-95838112
Telefax: +39-02-95309290 / 95838461

Japan

GRUNDFOS Pumps K.K.
Gotanda Metalion Bldg., 5F,
5-21-15, Higashi-gotanda
Shiagawa-ku, Tokyo
141-0022 Japan
Phone: +81 35 448 1391
Telefax: +81 35 448 9619

Korea

GRUNDFOS Pumps Korea Ltd.
6th Floor, Aju Building 679-5
Yeoksam-dong, Kangnam-ku, 135-916
Seoul, Korea
Phone: +82-2-5317 600
Telefax: +82-2-5633 725

Latvia

SIA GRUNDFOS Pumps Latvia
Deglava biznesa centrs
Augusta Deglava ielā 60, LV-1035, Rīga,
Tālr.: + 371 714 9640, 7 149 641
Fakss: + 371 914 9646

Lithuania

GRUNDFOS Pumps UAB
Smolensko g. 6
LT-03201 Vilnius
Tel: + 370 52 395 430
Fax: + 370 52 395 431

Malaysia

GRUNDFOS Pumps Sdn. Bhd.
7 Jalan Peguam U1/25
Glenmarie Industrial Park
40150 Shah Alam
Selangor
Phone: +60-3-5569 2922
Telefax: +60-3-5569 2866

Mexico

Bombas GRUNDFOS de México S.A. de
C.V.
Boulevard TLC No. 15
Parque Industrial Stiva Aeropuerto
Apodaca, N.L. 66600
Phone: +52-81-8144 4000
Telefax: +52-81-8144 4010

Netherlands

GRUNDFOS Netherlands
Veluwezoom 35
1326 AE Almere
Postbus 22015
1302 CA ALMERE
Tel.: +31-88-478 6336
Telefax: +31-88-478 6332
E-mail: info_gnl@grundfos.com

New Zealand

GRUNDFOS Pumps NZ Ltd.
17 Beatrice Tinsley Crescent
North Harbour Industrial Estate
Albany, Auckland
Phone: +64-9-415 3240
Telefax: +64-9-415 3250

Norway

GRUNDFOS Pumper A/S
Stråmsveien 344
Postboks 235, Leirdal
N-1011 Oslo
Tlf.: +47-22 90 47 00
Telefax: +47-22 32 21 50

Poland

GRUNDFOS Pompy Sp. z o.o.
ul. Klonowa 23
Baranowo k. Poznania
PL-62-081 Przeźmierowo
Tel: (+48-61) 650 13 00
Fax: (+48-61) 650 13 50

Portugal

Bombas GRUNDFOS Portugal, S.A.
Rua Calvet de Magalhães, 241
Apartado 1079
P-2770-153 Paço de Arcos
Tel.: +351-21-440 76 00
Telefax: +351-21-440 76 90

Romania

GRUNDFOS Pompe România SRL
Bd. Biruintei, nr 103
Pantelimon county Ilfov
Phone: +40 21 200 4100
Telefax: +40 21 200 4101
E-mail: romania@grundfos.ro

Russia

ООО Грундфос Россия
109544, г. Москва, ул. Школьная, 39-41,
стр. 1
Тел. (+7) 495 564-88-00 (495) 737-30-00
Факс (+7) 495 564 88 11
E-mail grundfos.moscow@grundfos.com

Serbia

Grundfos Srbija d.o.o.
Omladinskih brigada 90b
11070 Novi Beograd
Phone: +381 11 2258 740
Telefax: +381 11 2281 769
www.rs.grundfos.com

Singapore

GRUNDFOS (Singapore) Pte. Ltd.
25 Jalan Tukang
Singapore 619264
Phone: +65-6681 9688
Telefax: +65-6681 9689

Slovakia

GRUNDFOS s.r.o.
Prievozská 4D
821 09 BRATISLAVA
Phona: +421 2 5020 1426
sk.grundfos.com

Slovenia

GRUNDFOS d.o.o.
Štandrova 8b, SI-1231 Ljubljana-Črnuče
Phone: +386 31 718 808
Telefax: +386 (0)1 5680 619
E-mail: slovenia@grundfos.si

South Africa

GRUNDFOS (PTY) LTD
Corner Mountjoy and George Allen Roads
Wilbart Ext. 2
Bedfordview 2008
Phone: (+27) 11 579 4800
Fax: (+27) 11 455 6066
E-mail: lsmart@grundfos.com

Spain

Bombas GRUNDFOS España S.A.
Camino de la Fuentesilla, s/n
E-28110 Algete (Madrid)
Tel.: +34-91-848 8800
Telefax: +34-91-628 0465

Sweden

GRUNDFOS AB
Box 333 (Lunnagårdsgatan 6)
431 24 Mölndal
Tel.: +46 31 332 23 000
Telefax: +46 31 331 94 60

Switzerland

GRUNDFOS Pumpen AG
Bruggacherstrasse 10
CH-8117 Fällanden/ZH
Tel.: +41-44-806 8111
Telefax: +41-44-806 8115

Taiwan

GRUNDFOS Pumps (Taiwan) Ltd.
7 Floor, 219 Min-Chuan Road
Taichung, Taiwan, R.O.C.
Phone: +886-4-2305 0868
Telefax: +886-4-2305 0878

Thailand

GRUNDFOS (Thailand) Ltd.
92 Chaloem Phrakiat Rama 9 Road,
Dokmai, Pravej, Bangkok 10250
Phone: +66-2-725 8999
Telefax: +66-2-725 8998

Turkey

GRUNDFOS POMPA San. ve Tic. Ltd. Sti.
Gebze Organize Sanayi Bölgesi
Ihsan dede Caddesi,
2. yol 200. Sokak No. 204
41490 Gebze/ Kocaeli
Phone: +90 - 262-679 7979
Telefax: +90 - 262-679 7905
E-mail: satis@grundfos.com

Ukraine

Бізнес Центр Європа
Столичне шосе, 103
м. Київ, 03131, Україна
Телефон: (+38 044) 237 04 00
Факс: (+38 044) 237 04 01
E-mail: ukraine@grundfos.com

United Arab Emirates

GRUNDFOS Gulf Distribution
P.O. Box 16768
Jebel Ali Free Zone
Dubai
Phone: +971 4 8815 166
Telefax: +971 4 8815 136

United Kingdom

GRUNDFOS Pumps Ltd.
Grovebury Road
Leighton Buzzard/Beds. LU7 4TL
Phone: +44-1525-850000
Telefax: +44-1525-850011

U.S.A.

GRUNDFOS Pumps Corporation
17100 West 118th Terrace
Olathe, Kansas 66061
Phone: +1-913-227-3400
Telefax: +1-913-227-3500

Uzbekistan

Grundfos Tashkent, Uzbekistan The
Representative Office of Grundfos
Kazakhstan in Uzbekistan
38a, Oybek street, Tashkent
Телефон: (+998) 71 150 3290 / 71 150
3291
Факс: (+998) 71 150 3292

Addresses Revised 29.09.2015

96646512 1115

ECM: 1163899
