

MiniCODER

Speed and position sensor
with sin/cos- or square-wave output

GEL 2432

Technical information

Version 01-2019

Description

- Integrated MR sensors for contactless scanning of a measuring scale (target wheel or measuring rod)
- Output as square-wave or sinusoidal signals
- Sensor signals are internally enhanced and temperature-compensated
- High resolution by internal interpolation of square-wave signal output (interpolation factor selectable ex works)
- Sin/cos output with amplitude regulation
- Power supply is reverse-polarity protected
- Outputs are short-circuit proof
- Target wheels available separately

Output signals

- Two 90° phase-offset square-wave signals with inverse signals 5 V TTL / RS422
- Sin/cos-signals 1 V_{pp} with inverse signals

Properties

- Frequency range 0 to 200 kHz
- Contactless measurement of rotational motion on target wheels with modules 0.5 and 1.0
- Contactless measurement of linear motion on measuring rods with pitches of 1.0 / 1.6 or 2.0 mm
- Useable under the most severe conditions
- Degree of protection IP 67, sensor side chemically resistant
- Fully encapsulated electronics

Fields of application

- Registering the movement of piston rods on diecasting machines
- Contactless measurement of speeds and positions on machines and motors



Right to technical changes and errors reserved.

Internet: www.lenord.com
E-Mail: info@lenord.de
Phone: +49 208 9963-0

Lenord, Bauer & Co. GmbH
Dohlenstraße 32
46145 Oberhausen, Germany

 **LENORD
+BAUER**

Technical data

Signal pattern	K	T
Electrical Data		
Supply voltage V_S (reverse battery protected)	5 V DC \pm 5%	5 V DC \pm 10%
Power consumption without load	\leq 0.6 W	
Measuring frequency	0 to 200 kHz at a line capacity of 5 nF	
Max. permissible cable length	100 m, depending on the frequency and cable capacity (test the voltage drop on the power line!)	
Output signals	Two 90° phase-shifted push-pull signals, short-circuit proof Sin/cos	Square-wave
Output level	1 V_{pp} +0.1/-0.2 V_{pp} differential signal	5 V TTL
Offset (static)	< 60 mV	—
Amplitude ratio V_{tr1} / V_{tr2}	0.9 to 1.1	
Electromagnetic compatibility	EN/IEC 61000-6-1: 2007-10 EN/IEC 61000-6-2: 2006-03 EN/IEC 61000-6-3: 2007-08 EN/IEC 61000-6-4: 2007-09	
Insulation stability	500 V, according to EN/IEC 60439-1: 2012-06	
Mechanical Data		
Measuring scale	Target wheel or measuring rod made of ferromagnetic steel	
Width of the target wheel	\geq 3 mm	
Diameter of the measuring rod	\geq 12 mm	
Admissible air gap	See the mounting sketches	
Working temperature	-20 °C to +85 °C	
Operating temperature	-20 °C to +85 °C	
Storage temperature	-30 °C to +100 °C	
Degree of Protection	IP 67 (with plug being mounted)	
Vibration resistance	200 m/s ² , according to EN/IEC 60068-2-6: 2008-10	
Shock resistance	2000 m/s ² , according to EN/IEC 60068-2-27: 2010-02	
Weight	20 g	
Housing	Sensor tube: stainless steel 1.4305 Cap: PPS, oil-resistant	

Dimensional drawings

All dimensions in mm; General tolerance DIN ISO 2768 -mK

Dimensional drawing GEL 2432

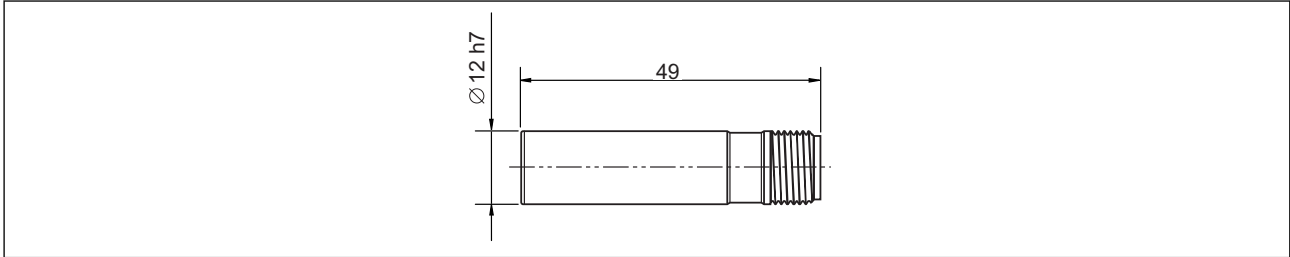

Dimensional drawing GG 600 (Cable with moulded plug, straight outlet)

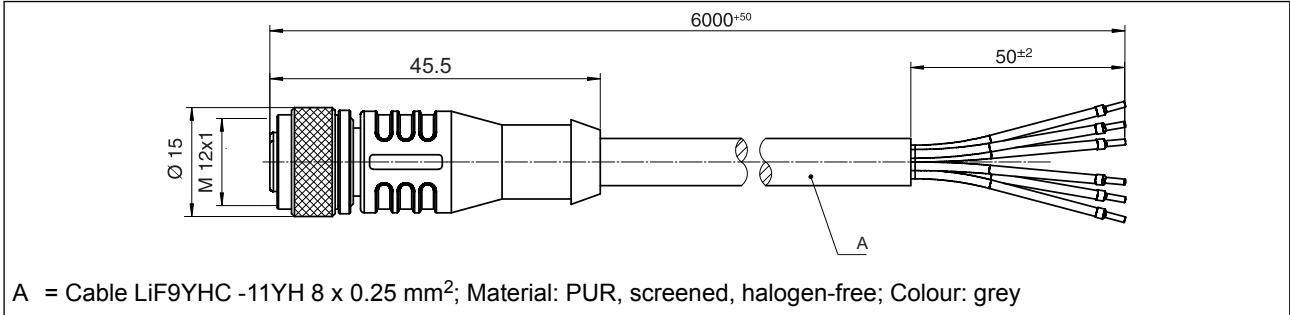

Dimensional drawings GW 600 (Cable with moulded plug, side outlet)

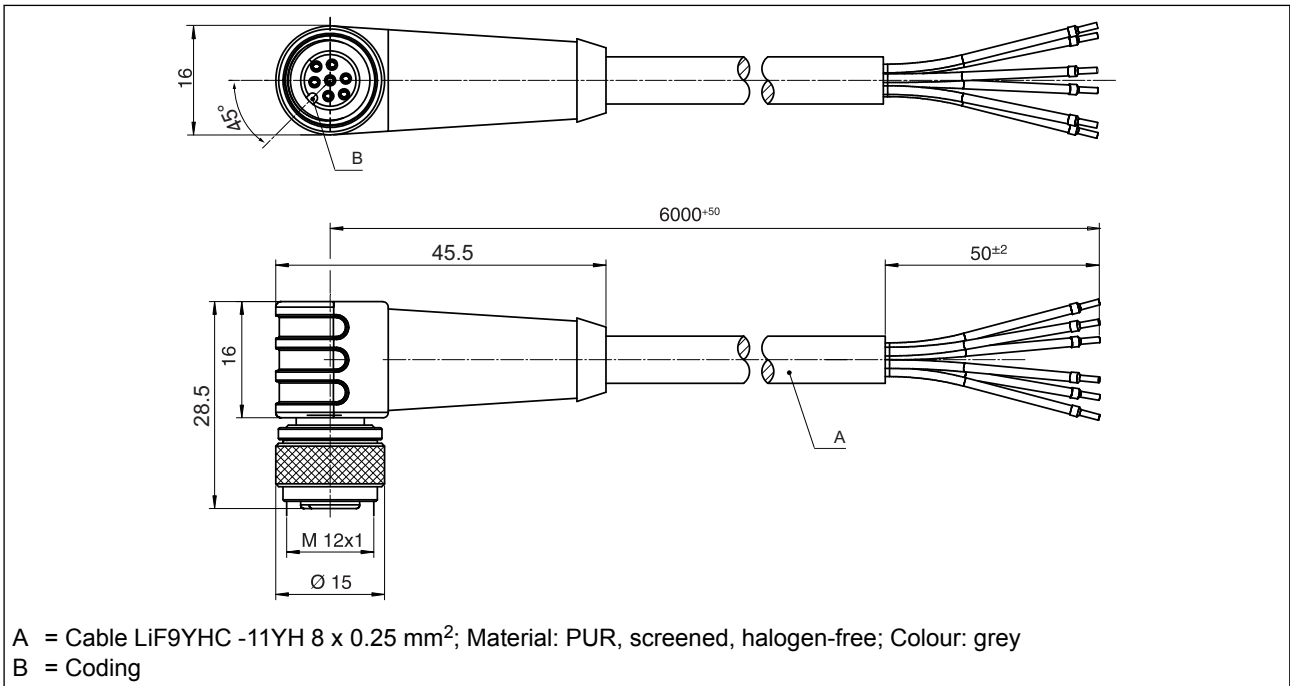

Measuring scales

Measuring rods

Fields of application

- Length measurements
 - Scanning measuring rods with pitch 1, 1.6 oder 2 mm
- GEL 2432 series MiniCODERs can be used in combination with measuring scales to determine positions of linear movements. The measuring scale used is a graduated surface structure that can be applied to any desired ferromagnetic machine elements.

For longitudinal measurements, ferromagnetic toothed or piston rods may be used with hard chrome plating as protection against contamination (the pitch structure may be filled up with copper, for instance).

Measuring rod

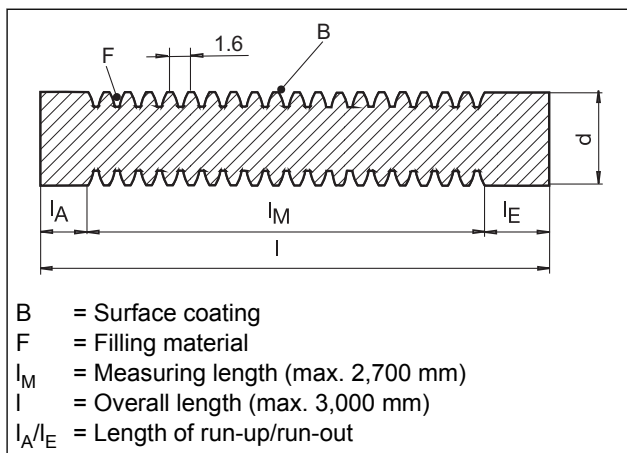

Target wheels

Fields of application

- Measurement of speeds and positions with target wheels
 - Scanning target wheels with module 0.5 or module 1
- The type of MiniCODER that is used to detect rotational motion forms a unit with its target wheel. The size of the target wheel, and hence the diameter of the unit thus depend directly on its module and number of teeth. The following formulae are used:

$$z = (d_a / m) - 2$$

$$d_a = m \cdot (z+2)$$

d_a = external diameter

m = module

z = number of teeth

Customer-specific target wheel

Target wheels can be specially manufactured for individual customers' requirements. Please send us a construction drawing of the desired target wheel (if possible in the form of a DXF file).

- 1) Distance tolerance applies to sin/cos signals with internal regulation and square-wave signals with interpolation factor 1. Higher interpolation factors have a longer distance tolerance.

Instructions, EMC notes and connection assignment

Mounting instructions

- Align the MiniCODER symmetrically with respect to the measuring scale. Asymmetries lead to measuring errors.
- Avoid mechanical contact between the measuring scale and the 0.1 mm thick protective layer of the sensor system. Scratching this protective layer can cause complete failure of the MiniCODER.
- Do not damage the surface of the toothing. Do not permit any mechanical components to run on this surface.

The MiniCODER must be mounted in such a way that the three collinear pins are aligned in the direction of movement of the measuring rod. Observe the position of the plug key in order to establish the counting direction (see connection assignment).

Assembly with measuring rod

Module [mm]	Pitch [mm]	Air gap L preset measure	Distance tolerance ⁽¹⁾
-	1.0	0.15 mm	± 0.05 mm
-	1.6	0.25 mm	± 0.05 mm
-	2.0	0.30 mm	± 0.05 mm

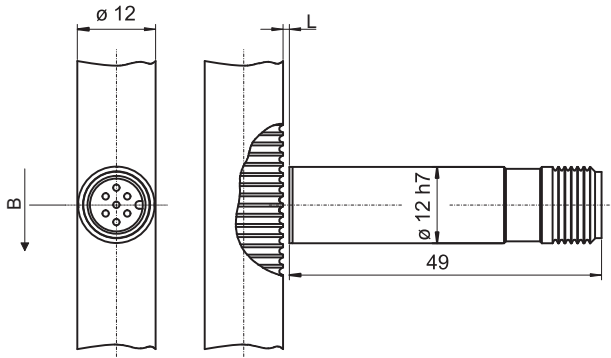

B = Direction of movement
L = Air gap

Assembly with target wheel

Module [mm]	Pitch [mm]	Air gap L preset measure	Distance tolerance ⁽¹⁾
0.5	-	0.25 mm	± 0.05 mm
1.0	-	0.50 mm	± 0.10 mm

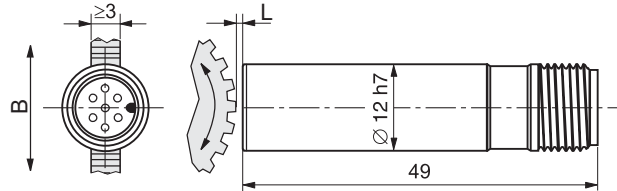

B = Direction of movement
L = Air gap

Notes on electromagnetic compatibility

To improve the electromagnetic environment please observe the following instructions:

- Connect the screens using large surface area connections.
- Keep all unscreened cables as short as possible.
- Design the earth connections with a large cross-section (e.g. using a low inductance earth strap or flat conductor) and keep them short.
- If there are potential differences between machine earth connections and electronic earth connections, ensure no equalising currents can flow over the cable screen. For this purpose, e.g. lay an equipotential bonding cable with a large cross-section or use cable with separate double screening. In case of cables with separate double screening, only connect the screens at one end.
- Lay the signal cables and control lines separate from the power cables. If this is not possible, use screened twisted pair cables and/or lay the encoder cable in a steel conduit.
- Make sure that surge protective measures have been carried out externally (EN 61000-4-5).

Connection assignment

Lead colour	Pin	Signal/ function		Waveform		Probe
Green	1	U_{1+}	Track 1			
Yellow	2	U_{1-}	/Track 1			
White	3	0 V	GND	Ground		
Brown	5	$+U_B$	+ 5 V DC	Supply voltage		
Grey	6	U_{2+}	Track 2			
Rose	7	U_{2-}	/Track 2			
Screen	—	Connected to the sensor tube through the plug.				

⁽¹⁾ Distance tolerance applies to sin/cos signals with internal regulation and square-wave signals with interpolation factor 1. Higher interpolation factors have a longer distance tolerance.

Type code, accessories

Type code

2432	Signal pattern K Sin/Cos signals 1 V _{PP} T Square-wave signals 5 V TTL / RS 422
	Interpolation factor / amplitude control Signal pattern T only: 1 Multiplier 1 2 Multiplier 2 4 Multiplier 4 8 Multiplier 8 A Multiplier 10 B Multiplier 12 C Multiplier 16 D Multiplier 20 Signal pattern K only: R with internal amplitude control (mandatory)
	Module / pitch 1 Module m = 1.0, diametric pitch D.P = 25.4 (target wheel) 5 Module m = 0.5, diametric pitch D.P = 50.8 (target wheel) A Pitch p = 1.6 (measuring rod) B Pitch p = 2.0 (measuring rod) C Pitch p = 1.0 (measuring rod)
	Connection type 0000 No connecting cable C600 Connecting cable with extruded straight plug (L = 600 cm) D600 Connecting cable with extruded angulate plug (L = 600 cm)

Interpolation factor

An electronic module enables the sin/cos signals generated by the GEL 2432 to be interpolated directly.

For example, users can obtain 5000 square-wave signals from a precision 250-tooth target wheel with the selected interpolation factor D = 20 (higher factors are available on request).

The interpolation is carried out directly at the sensor. The four-flank evaluation facility in the control electronics can deliver an even higher resolution, in the above example 20,000 steps.

Accessories

Item no.	Description
Type code ⁽¹⁾	GEL 214 External interpolation electronics to convert sinusoidal signals to square-wave signals. For further information, see separate technical information.
BK1080	GG 600 Cable with moulded plug, straight, length 600 cm
BK1081	GW 600 Cable with moulded plug, angled, length 600 cm

⁽¹⁾ see separate technical information

Notes:



Lenord, Bauer & Co. GmbH
Dohlenstraße 32
46145 Oberhausen, Germany
Phone: +49 208 9963-0
Fax: +49 208 676292
Internet: www.lenord.com
E-Mail: info@lenord.de

Right to technical changes and errors reserved.