

POWER TRANSMISSION SOLUTIONS

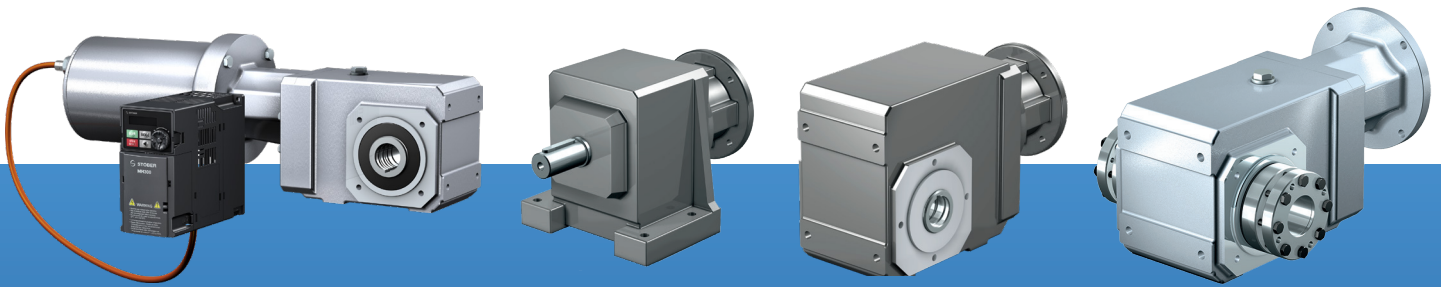

*Geared to a
higher standard™*

POWER TRANSMISSION SOLUTIONS



Welcome to STOBER!

And thank you for your interest in the cLEAN System offered by STOBER Drives, Inc.!

In 1934, the Stöber brothers founded a small shop in Pforzheim, Germany that made machines and repaired engines. Today, STOBER is an international organization with offices in eleven countries.

This 80 year heritage has given us expertise in gearing that makes STOBER the “gold standard.” STOBER products are of the highest quality and use only the best components.

This catalog covers our helical bevel gearboxes, as well as our new cLEAN System, featuring our KSS gearbox, cLEAN Motor, cLEAN Cable, and cLEAN Drive. STOBER is recognized across the United States for its solution design, product durability, and service support. We look forward to the opportunity to work with you, and to help with your cLEAN System needs.

Peter Feil, General Manager, STOBER Drives, Inc.



STOBER Drives Inc. was founded in 1991. Our Maysville, Kentucky campus includes 85,000 square feet of sales and service offices, assembly, manufacturing, and warehousing space for German-engineered STOBER products for 1 day shipment nationwide.

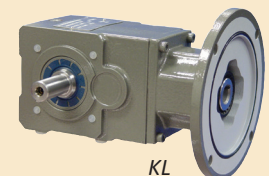
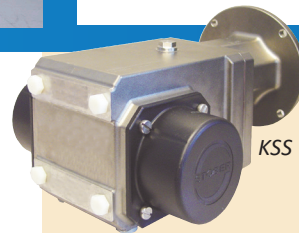

Contents

About STÖBER Drives			2
Special Features			4
Overview At-a-Glance			8
Sizing/Selection			10
KSS with cLEAN Motor			12
Stainless Steel IP69K Certified	KSS	Right-Angle	50
Standard Duty Coating	K/KL	Right-Angle	68
Food & Corrosion Resistant Coatings:			
• 316SS Epoxy	C	Inline	114
• Anti-Microbial			
• IP69K Certified*	F	Offset Inline	148
*Not available on S Series			
Technical Reference			168
Terms & Conditions of Sale			174
Other STÖBER Drive Products			175

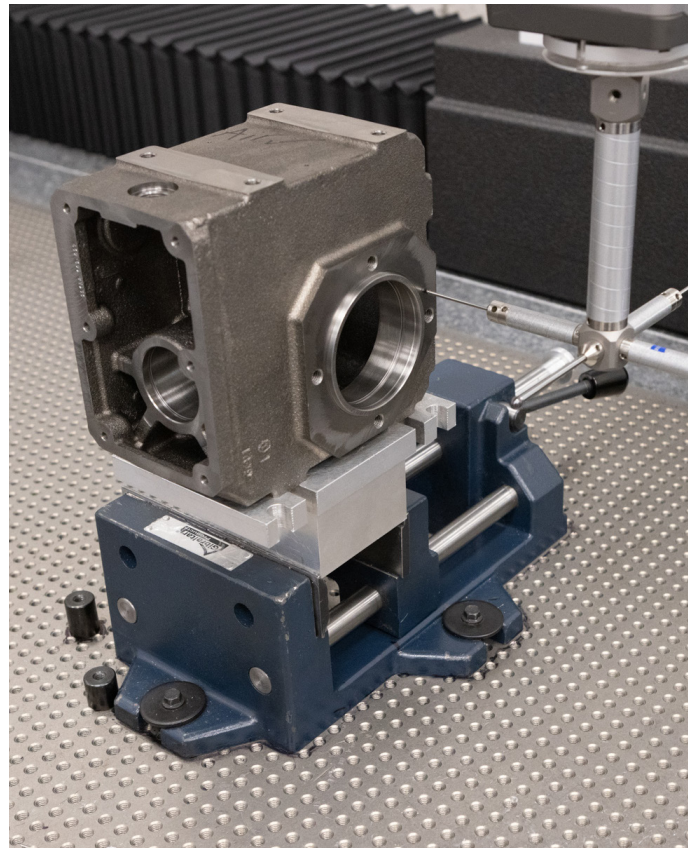

All manufactured components are inspected before being released to assembly. Our quality inspection team ensures every part meets tolerances and is in spec.

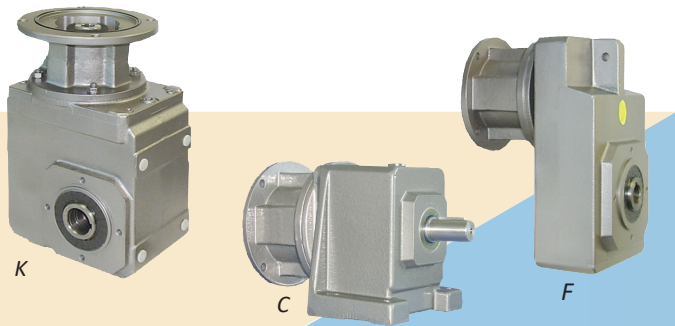

Unsurpassed:

STÖBER products are designed and built to perform for the toughest applications. Reliability, adaptability and maintainability are our focus, and durability is truly our trademark.

Solution Designs that build quality around every requirement.

Product Durability that enhances the reliability and life of every application.

Service Support that is empowered to meet and exceed client expectations.

STÖBER Serviced Industries:

- Material Handling and Conveyors
- Food & Beverage
- Meat processing and packing
- Poultry
- Dairy
- Baking
- Shingles
- Tires
- and many others...



POWER TRANSMISSION SOLUTIONS

The Best you Can Buy...

At STÖBER, offering the best is not a buzz word — it is our passion and way of life. We offer the best product, provided by the best people and processes, and backed by the best service.

Why is STÖBER considered the industry Gold Standard? Our products are backed with superior service, outstanding quality, and the STÖBER guarantee.

The STÖBER Gold Standard: “Total Cost of Ownership” Savings

- STÖBER speed reducers survive in the toughest environments, providing long life under extreme conditions. Their high reliability and durability saves downtime and cost.
- Our product reliability is backed by one of the best warranties in the industry.
- We build and ship in 1 day saving you inventory hassle and cost.
- Our gearboxes adapt to standard NEMA C-face motors size 56C to 356TC.



Key STÖBER Numbers

IE5 Energy Efficiency

1 day shipping

15 minutes - program to 1 hour quoting

100% inspection and testing

24/7 customer service



The MGS® Difference

STÖBER MGS® Speed Reducers are the most efficient units on the market (97% efficiency). This saves money on energy costs and helps optimize and maintain your total operational performance with highly effective equipment:

- Smoother running, better efficiency
- Leakage free, maintenance free
- Runs cool – a difference you can feel
- Runs measurably quieter
- Lower backlash
- Long, maintenance-free life design advantages:
 - Magnetic drain plugs to capture internal particles
 - Flexible coupling eliminates misalignment
 - Gears supported with dual bearings in one piece housing for structural rigidity
 - High quality gears and housings
 - Superior parts including SKF bearings, Simrit seals, Mobil food grade oil



Purpose: Deliver peace of mind in the demanding world of motion.

Vision: The gold standard for perfect motion.

Mission: STÖBER puts things into motion...
...intergrally and precisely
...as a team with personality
...responsibly and in a forward-looking manner.



Striving Harder to Deliver the Best Gear Solutions

STÖBER Drives has been assembling products at our Maysville, Kentucky facility for over twenty years. Our expertise in the production and assembly of low-backlash gear units produces products that comply with the highest quality standards.

But, we don't remain satisfied with the status quo. We are continuously enhancing our modern machining production center including numerous recent acquisitions to improve our manufacture time and to ensure maximum quality levels.

Service Support for a Lifetime

We stand behind every drive we sell, which is why our service support is also the gold standard in the industry:

STÖBER takes pride in offering knowledgeable, factory-trained USA-based service support for our customers. When you call, you won't get a call center on the other side of the globe. Your call is answered in 3 rings or less, letting you know you've found a support system that values your time.

Application Support Programs

- For support during normal business hours: call 800-711-3588 or email sales@stober.com
- 24/7 emergency customer service hotline: 606.563.6035
- Consultative product support team available via phone or live chat on our website
- Application Sizing Software
- Online web tools: CAD and configurator
- On-site training available
- Emergency shipments available 24/7

The cLEAN System

Geared to a higher standard™

The World's Toughest System

STOBER has been innovating and optimizing gearbox solutions for the food and beverage industry since 1997. Designed with decades of knowledge and experience, STOBER's new cLEAN system was created to provide a durable system that improves your plant's reliability.

The STOBER cLEAN System features our KSS stainless steel gearbox, cLEAN Motor, cLEAN Drive, and cLEAN Cable. Not only can it withstand the harshest washdowns, it's highly efficient, easy to install, and everything is backed with a 3 year warranty.

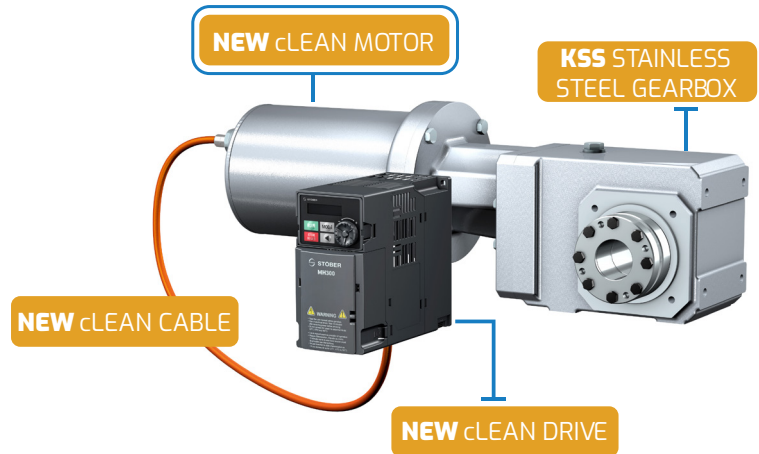

How We Stop Ingress:

- Zero weep holes
- Double seals on motor covers and all connection points
- O-ring and gland in the cable connection
- Designed to EHEDG Standards and is P69K Certified

Available with resolver encoder option for motor feedback!

Available with brake!

The Ultimate Energy Efficiency to Future-Proof Your Production – IE5

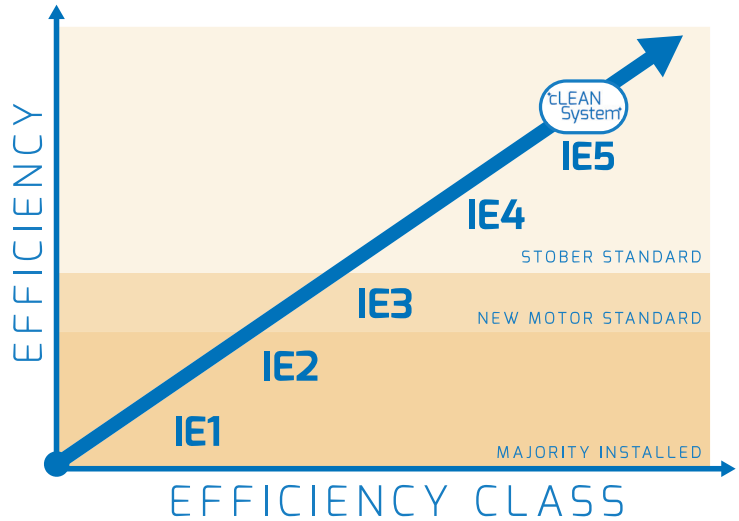

RUNS COOLER - OPERATES 86°F COOLER

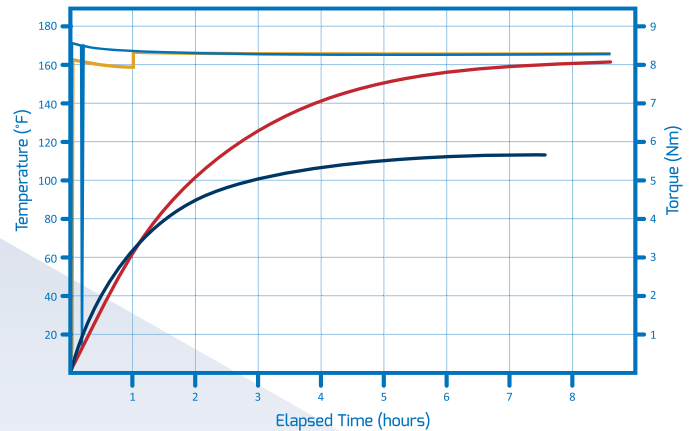

Weep holes on typical NEMA Motor

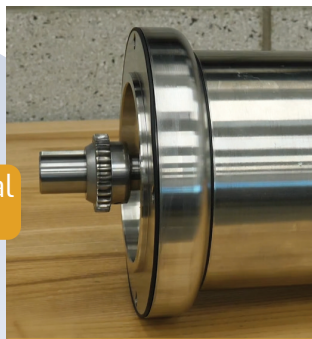

No weep holes on the cLEAN Motor



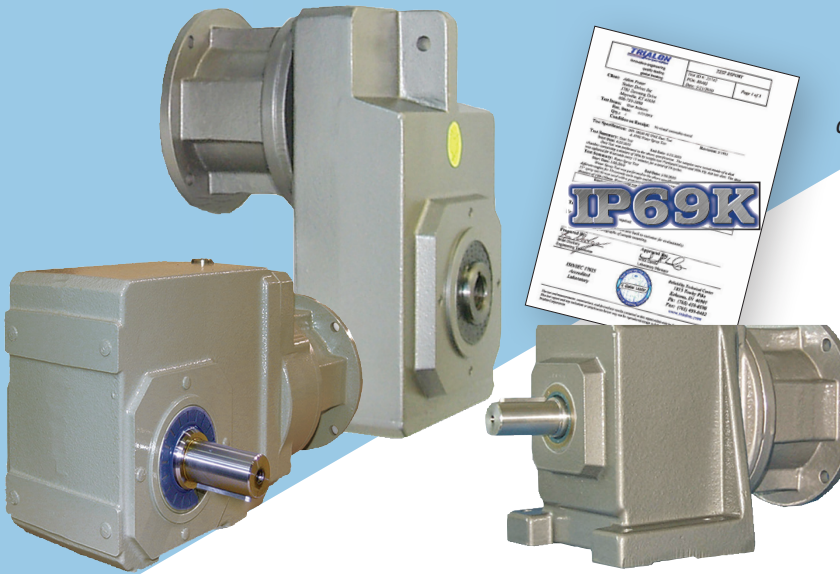

The KSS Series (inset box below) features an IP69K certified 304 stainless steel housing ideal for frequent pressure cleaning operations typical in the food industry and elsewhere.

K, KL, C and F Series are optionally available with 316 stainless steel epoxy coating for IP69K certified protection (K, F and C Series shown left to right).



Coatings

K KL C F

These speed reducers are available with 1 day turnaround on a choice of application-specific coatings:

Food Duty

- Primer
- Industrial 316 Stainless Steel Epoxy
- Silver Bullet Anti-Microbial® Epoxy (Silver Bullet AM® is a registered trademark of Burke Industrial Coating)

Corrosion Resistant Duty

- Primer
- Industrial 316 Stainless Steel Epoxy

Corrosion Resistant

KSS K KL C F

These units have several features and options for no maintenance operation in harsh washdown, wet, or dry environments.

- Maintenance free design: lifetime lubrication and double output seals (where possible)
- Stainless output bushing, shaft, or bore
- 3 year standard warranty
- Multilayer Industrial 316 stainless steel epoxy coating

- Finish is USDA accepted for food processing and handling; heat cured; IP69K sprayed at 1,450 PSI (100 bar)
- Lubricated for life with Mobil SHC CIBUS 220 for food duty, or Mobil 600XP220 for beverage duty or standard duty applications
- Totally enclosed – no breather to allow contaminants in or oil out and double output seals (dual lip outer seal and a single lip inner seal)
- The high quality helical gearing (and spiral bevel gearing in the “K” Series) is case hardened to 58-62 Rockwell C and precision finished for low noise and long service life. With an efficiency of 97%, these reliable drives provide cost savings in energy and maintenance.
- NEMA C-face input – with an O-ring between the motor and reducer and an easy mount maintenance free coupling
- Mounts in ANY horizontal output position (dependent on size and ratio) without changing oil levels (other positions are optional or warranty specific)
- ALL stainless steel hardware and stainless steel nameplate

IP69K Certified Speed Reducers: The Ultimate Solution for Extreme Duty High-Pressure Wash Downs!

IP69K Certified MGS Speed Reducers are sealed against dust and water ingress.

To prove the point, we tested all our IP69K rated products (KSS, K, C, F) with an absolute worst case situation to make sure they can handle your washdown needs — spraying the gear reducer with 176° water at 1,450 PSI from a distance of just 10-15 cm from the reducer.

None of the STÖBER units were damaged and continued to run both during and after the test.

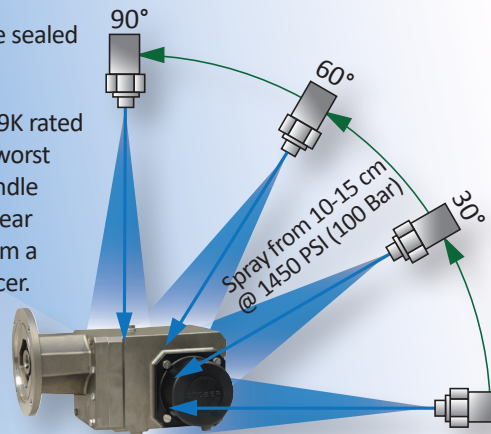

Unique STÖBER Quality and Design Features

Wobble Free Bushing Design

KSS F K KL

The STÖBER “Wobble Free” bushing is a patented double side wobble free bushing system that mounts easily onto standard cold finished, ground, or stainless shafting. This unique design allows the unit to be mounted on the shaft from either side of the reducer by reversing the clamp side and support side bushings. The clamp side is the accessible outside bushing.

The double sided bushing is not installed into the unit at assembly, but with quick, easy-to-follow instructions when the unit and bushing are mounted on the machine installation.

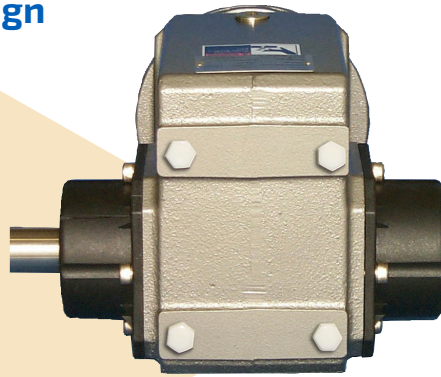

- Can be supplied with output covers on one or both sides which protect the seals and also cover the rotating bushing
- A variety of bushing bore sizes are provided for each reducer size. The reducer output bore can be changed any time by changing the bushing kit
- The quill, all bushing parts, and hardware can be supplied stainless steel to provide corrosion resistance for wash down applications

Interchangeable Support Side and Clamp Side

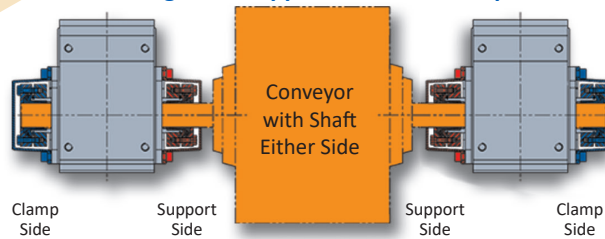

The distinct support side and a clamp side are interchangeable. The dual tapered cones are designed to overcome a wide range of tolerances normally found with standard shaft materials. No shaft key necessary.

The Tools to Help You



Download drawings, dimensional sheets, tech specifications, or request a quote!



Access all your product information (lubrication quantity, installation instructions, and more) through the serial number or QR code.

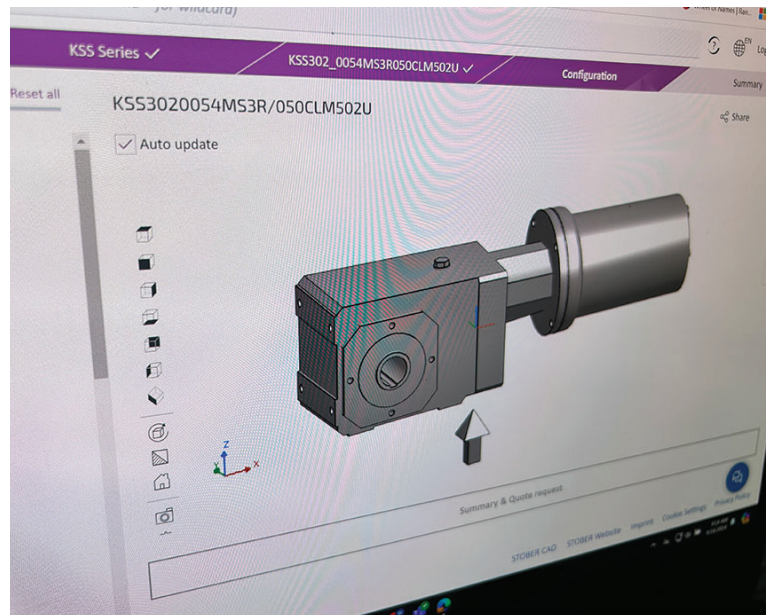

MGS® Speed Reducers At-a-Glance

Versatility

STOBER MGS® speed reducers offer the diversity and range to meet virtually any performance and environmental challenge

If you don't see exactly what you need, call your STOBER representative or STOBER customer service for assistance.

STAINLESS STEEL

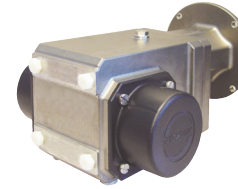

Configurations and Options

KSS

page 60

General	Input-Output Orientation	Right-Angle
	Gearing	Helical/Bevel
	Housing	Cast 304 SS
	Configurations	4 sizes; 2 or 3 stages
	Envelope Size (Min/Max L" x W"x H")	6.7 x 4.2 x 5.0 12.6 x 6.8 x 7.9
Performance	Input HP (Max)	1/8 to 5
	Output Torque – in-lbs (Max)	364 to 4872
	Output Speed RPM	6 to 435
NEMA C-Face Motor Compatibility (1750 RPM)	56C	•
	143/145TC	•
	182/184TC	•
	213/215TC	
	254/256TC	
	284/286TC	
	324/326TC	
	364/365TC	
Output	Solid Shaft	•
	Hollow Bore	•
	Wobble Free Bushing	•
Housing/Mounting	Round Flange	•
	Torque Arm Bracket	•
	Foot Mount	•
	Tapped Holes	•
	USDA Accepted Equipment	•
Protection	IP69K Certified	•
	IP69 Compliant	
	Housing	Totally enclosed – no breather
Hardware	Standard 3 year warranty	•
	Non-Plated	
	Plated	
Paint/Coatings	Stainless Steel	•
	Standard Gray	
	316SS Epoxy	
	Anti-Microbial Clear Coat	

Overview Selection At-a-Glance

IRON

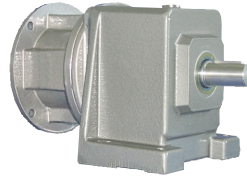
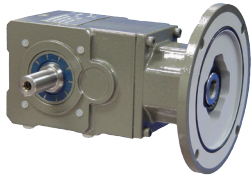

KL page 78	K page 78	C page 124	F page 158
Right-Angle	Right-Angle	Inline	Inline (Offset)
Helical/Bevel	Helical/Bevel	Concentric Helical	Offset Helical
Cast Iron	Cast Iron	Cast Iron	Cast Iron
1 size, 2 stages	10 sizes; 2, 3 or 4 stages	10 sizes; 2 or 3 stages	5 sizes; 2 or 3 stages
5.6 x 4.2 x 4.3	7.4 x 4.2 x 6.3 26.6 x 15.6 x 23.3	6.2 x 5.2 x 5.7 22.6 x 20.1 x 20.9	4.3 x 5.7 x 9.4 9.2 x 10.4 x 17.6
1/2 to 2	1/8 to 100	1/8 to 105.2	1/8 to 33
291 to 443	364 to 92,250	182 to 53,148	392 to 9,744
55 to 435	5* to 437	2.5* to 190	3* to 406
•	•	•	•
	•	•	•
	•	•	•
	•	•	•
	•	•	•
	•	•	•
	•	•	•
	•	•	•
•	•	•	•
•	•	•	•
•	•	•	•
• (Square)	•	• (Round or Square)	•
•	•	•	•
•	•	•	•
•	•	•	•
•	•	•	•
Opt	Opt	Opt	Opt
Totally Enclosed – no breather	**	**	**
•	•	•	•
•	•	•	•
Opt	Opt	Opt	Opt
Opt	Opt	Opt	Opt
•	•	•	•
Opt	Opt	Opt	Opt
Opt	Opt	Opt	Opt

*If a slower speed is needed, units can be combined to match application requirements. Contact STÖBER Drives Inc.
 •• Totally enclosed - no breather housing is optionally available on popular sizes.

Speed Reducer Sizing/Selection Requirements

To size an MGS speed reducer for any application, the following information is required:

1. Motor speed (all MGS selection data charts assume a 1750 rpm motor)
2. Desired output speed of the reducer (rpm) to meet the application requirement (refer to selection data charts within each product section, see the following example)
3. Input HP or output torque (lb-in) rating requirement of the application (use calculation below)
4. Overhung load limitations of application (use calculation at right)
5. Application Service Factor requirement (use tables on the facing page)

If you have any questions or need assistance selecting the best speed reducer for your application, please contact your STÖBER representative or STÖBER Technical Support.

Once the appropriate MGS speed reducer has been determined use the selection data tables (see sample below), to make the appropriate model selection for the application:

- 1 Use RPM Output (Approximate) nearest the application requirement.
- 2A Determine Input HP rating that is greater than or equal to the application required HP, or;
- 2B If selection is based on Torque instead of HP, find an Output Torque that is equal to or greater than required.
- 3 Confirm acceptable overhung load
- 4 Select Base Module and Motor Adapter part number

Complete the part number by selecting the appropriate options from the table located at the beginning of each product section.

Calculating Overhung Load

Pulling forces or overhung load of pulleys, sheaves, sprockets, etc. on the reducer input and output shaft must not exceed the allowable overhung load limits shown in the Selection Data tables within each product section.

The overhung load is measured at the center of the shaft extension. Hollow output units are not intended to support overhung loads. If an overhung load rating is required, use 50% of the published overhung load from the Selection Data. Contact STÖBER Technical Support, if assistance is needed.

The following formula can be used to determine actual overhung load for a given drive:

$$OHL = \frac{126,000 \times HP \times K}{D \times RPM}$$

Where:

OHL	Overhung Load (lbs)
HP	Horsepower
D	Pitch Dia. of Sprocket, Gear, Sheave, Pulley, etc.
RPM	Maximum Speed
	1.00 Chain Drives
	1.25 Gear Drives
K	1.25 Gearbelt Drives
	1.50 V-Belt Drives
	2.50 Flat Belt Drives

Selection Data

1750 RPM Input		Nominal Ratio	3 Overhung Load Output Shaft ¹⁾ (lbs)	4 Part Number Codes		Compatible NEMA C-Frame ² with Designated Motor Adapter
2A Input HP	2B Output Torque (lb-in)			Base Module	Motor Adapter Adder	
1 435 RPM Output (Approximate)						
2.61	364	4.000	402	KSS102_0040	MS1R050	56C
7.00*	979	4.000	483	KSS202_0040	MS2R050	56C
					MS2R140	143/145TC
9.22*	1,289	4.000	563	KSS302_0040	MS3R050	56C
					MS3R140	143/145TC
					MS3R180	182/184TC

Calculating Input HP or Output Torque

MGS speed reducers can be selected by either HP or Output Torque. The following formulas can be used to convert horsepower to torque or torque to horsepower.

$$HP = \frac{\text{Torque (in/lbs)} \times \text{Output Speed (RPM)}}{63,025}$$

$$\text{Torque (in/lbs)} = \frac{HP \times 63,025}{\text{Output Speed (RPM)}}$$

No overhung load is encountered when an MGS reducer is flange mounted and/or coupling connected to another unit. However, the shafts of all components must be accurately aligned and secured to prevent pre-loading of the bearings and premature bearing failure.

Determining Service Factor

Use one of the following two methods to determine the service factor of the speed reducer application.

Note: Service Factor should be determined for conditions such as non-uniform load, hours of service, and elevated ambient temperature. (For applications powered by an AC motor, a Service Factor of 2.0 is normally sufficient.)

Method 1.

Establish a Service Factor (SF) when the driven equipment and service class are known, use Table 1.

Method 2.

Establish a Service Factor (SF) when conditions are known, but the service class is NOT Known, use the information in Tables 2 – 6 below applied to the following equation:

$$SF = f_B \times f_T \times f_L \times f_V$$

Once the service factor has been determined, be sure to choose an MGS speed reducer that will meet or exceed:

$$HP \times SF \text{ or } \text{Torque (in/lbs)} \times SF$$

NOTE: Do not Service Factor the motor.

Table 1. Service Class I, II, III

Operating Conditions – not all inclusive. Each application should be checked to determine if any unusual conditions are present. See also Tables 3-5.

Service Class	Service Factor	
I	1.25	Moderate Shock – not more than 15 minutes in 2 hours
		Uniform Load – not more than 10 hours per day.
II	1.40	Moderate Shock – not more than 10 hours per day.
		Uniform Load – more than 10 hours per day.
III	1.75	Heavy Shock – not more than 15 minutes in 2 hours.
		Moderate Shock – more than 10 hours per day.
III	2.00	Heavy Shock – not more than 10 hours per day.
		Heavy Shock – more than 10 hours per day.

Type of Equipment	Hrs/Day	
	3-10	>10
Agitators		
Pure Liquids	I	II
Semi-Liquids, variable density	II	III
Solids	III	III
Brewing and Distilling		
Bottling Machinery	I	II
Brew Kettles (continuous duty)		II
Cookers (continuous duty)		II
Mash Tubs (continuous duty)		II
Scale Hopper (frequent starts)	II	II
Can Filling Machines	I	II
Car Dumpers	III	III
Clarifiers	I	II
Classifiers	II	II
Conveyors (uniform load and fed)		
Apron	II	II
Assembly Belt (bucket or pan)	II	II
Chain - Flight	II	II
Oven - Live Roll - Screw	I	II
Conveyors (non-uniform load and fed)		
Apron	II	III
Assembly Belt (bucket or pan)	II	II
Chain - Flight	II	II
Live Roll	*	*
Oven - Screw	II	II
Reciprocating - Shaker	III	III

* Contact STOBBER Drives

Type of Equipment	Hrs/Day	
	3-10	>10
Elevators		
Bucket (uniform load)	I	II
Bucket (nonuniform load - heavy duty)	II	III
Centrifugal Discharge	I	II
Freight	II	II
Gravity Discharge	I	II
Food Industry		
Slicer	II	III
Bottling, Can Filling Machines	I	II
Cereal Cooker	I	II
Mixer, Grinder	III	III
Line Shafts		
Uniform load	I	II
Nonuniform, Heavy Duty	II	III
Machine Tools		
Auxiliary Drive	I	II
Main Drive - uniform load	II	II
Main Drive - nonuniform Load	III	III
Table Conveyors (non reversing)		
Group Drives	II	III
Individual Drives	III	III
Wire Drawing, Flattening, Winding	II	III
Mixers		
Concrete - Continuous	II	III
Concrete - Intermittent	III	III
Constant Density	II	III
Semi-Liquid	III	III
Sewage Disposal Equipment		
Bar Screens	I	II
Chemical Feeders	I	II
Collectors	I	II
Dewatering Screws	II	II
Scum Breakers	II	III
Slow or Rapid Mixers	III	III
Thickeners	II	II
Vacuum Filters	II	II
Screens		
Air Washing	I	II
Rotary - Stone or Gravel	II	II
Traveling Water Intake	I	II
Skip Hoists	II	III
Slab Pushers	II	III
Stokers	II	II
Textile Industry		
Batchers or Calenders	II	II
Cards	I	II
Card Machines	III	III
Dry Cans and Dryers	II	II
Dyeing Machines	*	III
Looms	*	*
Mangles, Nappers and Pads	II	II
Soapers, Tenner Frames	II	II
Sinners, Washers, Winders	II	II
Tumbling Barrels	III	III
Windlass	II	III

Table 2. Load Factor (f_B)

Uniform Load.....	1.0	Medium Shock..	1.4
Non-uniform Load	1.25	Severe Shock	1.6

Contact STOBBER Technical Support for selection assistance on applications requiring frequent starts and stops.

Table 3. Ambient Temperature Factor (f_T)

f _T	Ambient Temperature (°F)					
	32	50	70	85	100	120
f _T	1.15	1.15	1.0	1.0	1.15	1.3

For temperatures less than 32° or greater than 120°, contact STOBBER Technical Support.

Table 4. Hours of Service Factor (f_L)

f _L	Hours of Service						
	2	4	6	8	12	16	24
f _L	0.75	0.85	0.95	1.0	1.10	1.15	1.20

Table 5. Torque Characteristics (f_V)

Use for Frequency Convertor Only

Constant torque over entire speed variation	1.0
Increasing output torque from 87 – 50 Hz	1.7

cLEAN System: GEARBOX & MOTOR

Features

- All stainless steel hardware
- Output bore diameters up to 1-1/2"
- Gearbox Housing style options: feet, flange, torque arm bracket, or tapped holes
- High frequency injection technology
- Speeds from 0 - 3000 RPM
- IE5 Efficiency
- Double seals on all ingress points

The KSS and cLEAN Motor are both IP68 and IP69K Certified, capable of handling the harshest washdowns. They are totally enclosed preventing water ingress and eliminating premature failure.

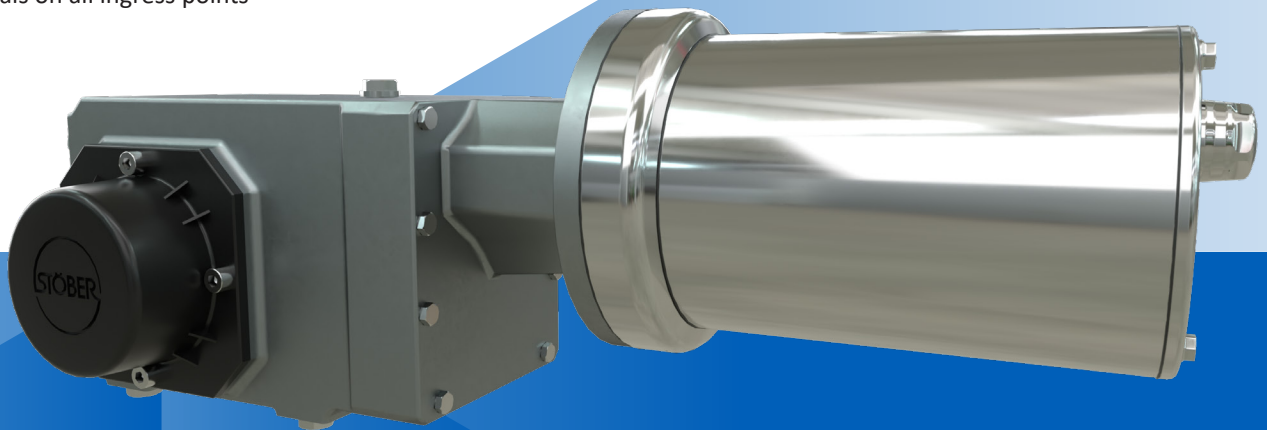

Benefits

- 3 year warranty
- Compact - 1/3 smaller than competitor motors
- Runs cooler - 86°F cooler than competitor motors
- No maintenance - totally enclosed with no breather to prevent contaminants in or oil out
- Lubricated for life with Mobil SHC CIBUS 220 food grade oil
- No harborage point for bacteria
- Simple motor mounting and removal with Bowex coupling system
- Energy savings - up to 92% efficiency
- IP68 and IP69K Certified to prevent water and dust ingress
- Designed to EHEDG Standards
- Assembled in USA
- 1 day lead time
- UL Certified
- Available with Resolver encoder option for motor feedback
- Available with brake

Overview

IP68 and IP69K CERTIFIED



Ordering Options At-a-Glance

Use the appropriate order codes below to build a part number for the complete assembly.

Part Number Example: 1 2 3 4 5 6 7 8 9 0*

Part Number Example: KSS 1 0 2 W G 0040 MS1R 050 E1256

Design Option	Part Number Code	Description
1 Series	KSS	Stainless steel housing; right angle helical/bevel
2 Size	1 2 3 4	4 sizes of speed reducers
3 Generation	0	Version of speed reducers
4 # of Stages	2 3	Two stage or three stage
5 Output	A	Hollow bore output
	V	Solid shaft output (specify side 3, 4 or double sided)
	W	Double wobble-free bushing
6 Housing	F	Round output flange (specify side 3 or 4)
	G	Pilot Circle Diameter (PCD) tapped holes
	GD	Torque arm bracket
	NG	Foot mounting (specify side 1 or 5)
7 Ratio	0040	Ratios range from 4:1 to 272:1 (refer to Selection Data tables)
8 Motor Adapter	MS1R	For KSS1
	MS2R	For KSS2
	MS3R	For KSS3
	MS4R	For KSS4
9 NEMA Frame Size	050	56C
	140	143/145TC
	180	182/184TC
0 Mounting Position* <i>Refer to page 62 illustrations</i>	EL1256	Mounting positions for 3 year warranty
	E34	

*Note: Mounting position is added to "notes" section of order.

Part Number Example: 1 2 3 4 5 6 7 8 9 10 11 12

Part Number Example: CLM 5 0 2 U S HF RO P 201 S /140

Design Option	Part Number Code	Description
1 Series	CLM	cLEAN motor - all stainless steel
2 Size	5	1 size
3 Generation	0	Version of motor
4 Length	2 3 5	Number of motor magnet stacks (2 is 1HP, 3 is 2HP, 5 is 3HP)
5 Cooling	U	Convection cooling
6 Design	S	Standard
7 Drive Controller	HF HG	HF - Delta MH300 HG - 3rd Party Drive
8 Encoder	00 RO	00 - No feedback RO - Resolver
9 Brake	O P	O - Without P - Permanent Magnet Brake
10 Voltage Constant	201	201 V/1000 rpm
11 Connection Method	S R	S - Straight R - Right Angle
	S R	
12 NEMA Frame Size	050	56C
	140	143/145TC
	180	182/184TC

CLEAN System

cLEAN System: GEARBOX & MOTOR

KSS Series Orientation

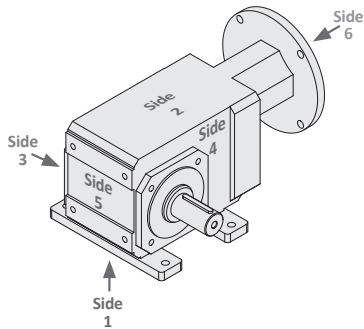

KSS Series Direction of Rotation

Output available on side 3, 4 or both. Note: With a double output, the shaft rotation of Side 3 will be the OPPOSITE direction of Side 4 when viewed from Side 5.

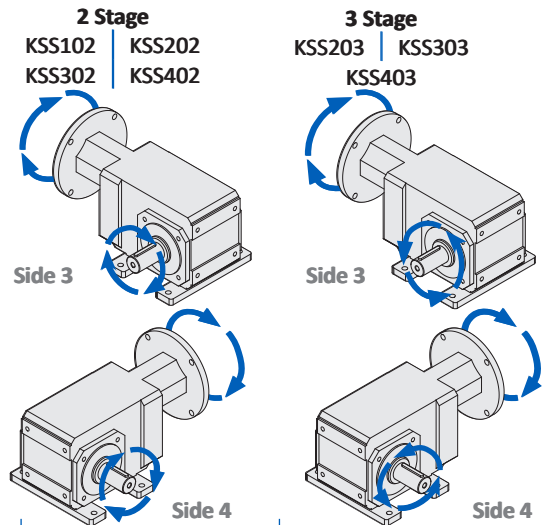

KSS Series Output Options

BLUE: standard output diameters in stock
BLACK: optional diameters in stock

All Outputs Stainless Steel (Inches)		KSS1	KSS2	KSS3	KSS4
"V" Solid Shaft	Inches	1	1-1/4	1-1/4	1-3/8
"A" Hollow Bore	Inches	1	1-1/4	1-3/8	1-1/2
"W" Wobble Free Bushing	Inches	1	1 1-3/16 1-1/4 1-3/8 1-7/16 1-1/2	1 1-3/16 1-1/4 1-3/8 1-7/16 1-1/2	1-3/16 1-1/4 1-3/8 1-7/16 1-1/2
	Metric	25	30 35	30 35	40

KSS Mounting Position Options

When ordering any KSS unit, the mounting position must be specified. Use one of the mounting position order codes illustrated below that corresponds to the intended application. KSS units are equipped with specialized seals, higher oil level, and additional features that enables all horizontal output positions to be used interchangeably.

Note that KSS units are equipped with specialized seals, higher oil level, and additional features that enables all horizontal output positions to be used interchangeably.

These four mounting positions are all interchangeable.

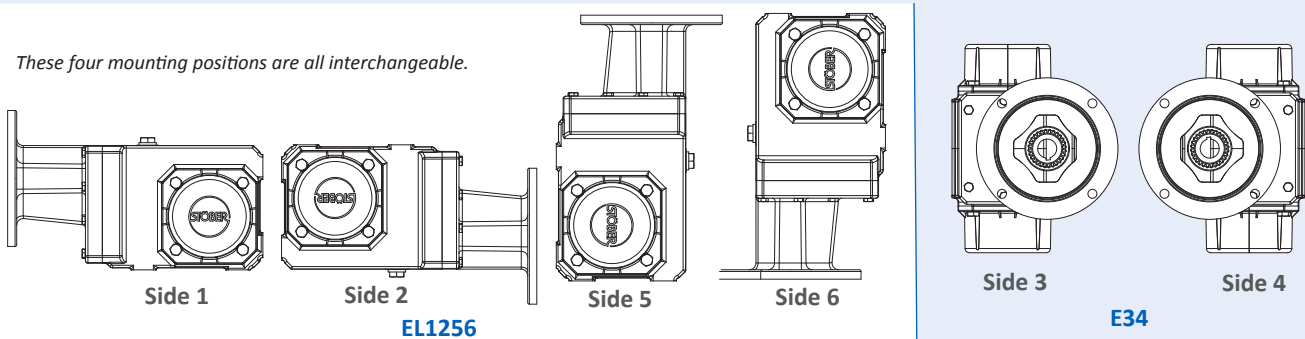

Output and Housing Configurations

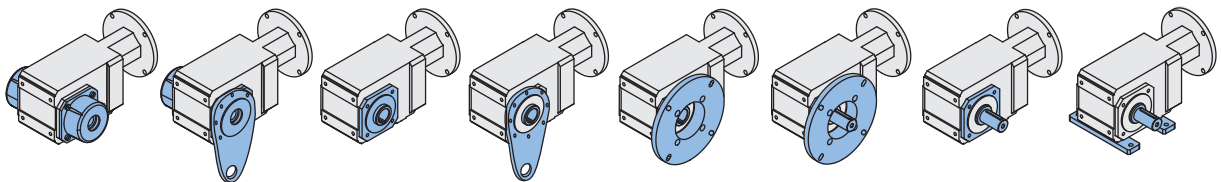

See Page	page 70	page 71	page 72	page 73	page 74	page 75	page 76	page 77
Output	W Double Bushing	W Double Bushing	A Hollow Bore	A Hollow Bore	A Hollow Bore	V Solid Shaft	V Solid Shaft	V Solid Shaft
Housing	G Tapped Holes	GD Torque Arm Bracket	G Tapped Holes	GD Torque Arm Bracket	F Round Flange	F Round Flange	G Tapped Holes	NG Foot Mount



cLEAN Sizing/Selection:

1. Find the **RPM Output (Approximate)** nearest to the application requirement. (If the exact Output RPM is required, divide the Input RPM [1800] by the value listed in the Nominal Ratio column.)
- 2a. In the **Input HP** column, locate the rating that is greater than or equal to the required HP, or;
- 2b. If selection is based on Torque instead of HP, find an **Output Torque** that is equal to or greater than required.
3. Confirm that the **Overhung Load** is acceptable for the application.

Part Number Codes	Compatible NEMA C-Frame ²⁾ with Designated Motor Adapter	Voltage	RPM Output	Ratio	Output Torque In. Lbs.	OHL (lbs)	Service Factor
1 HP Motor, 13 - 39 RPM Output (Approximate), 1800 RPM Input							
KSS403_1340 MS4R050 CLM502U	56C	230	13	134.399	4,538	2,518	1.1
		460					
KSS403_1070 MS4R050 CLM502U	56C	230	17	107.381	3,625	2,518	1.3
		460					
KSS303_0900 MS3R050 CLM502U	56C	230	20	90.061	3,041	1,574	1.0
		460					
KSS303_0780 MS3R050 CLM502U	56C	230	23	78.41	2,647	1,503	1.2
		460					
KSS403_0780 MS4R050 CLM502U	56C	230	23	78.095	2,637	2,402	1.8
		460					
KSS303_0670 MS3R050 CLM502U	56C	230	27	66.868	2,258	1,425	1.4
		460					
KSS303_0650 MS3R050 CLM502U	56C	230	27	65.499	2,211	1,416	1.4
		460					
KSS302_0560 MS3R050 CLM502U	56C	230	32	55.705	1,908	1,341	1.2
		460					
KSS402_0560 MS4R050 CLM502U	56C	230	32	55.705	1,908	2,146	2.0
		460					
KSS203_0540 MS2R050 CLM502U	56C	230	33	54.25	1,832	1,139	1.0
		460					
KSS303_0540 MS3R050 CLM502U	56C	230	33	53.883	1,819	1,326	1.7
		460					
KSS403_0540 MS4R050 CLM502U	56C	230	34	53.69	1,813	2,120	2.7
		460					
KSS203_0500 MS2R050 CLM502U	56C	230	36	49.759	1,680	1,107	1.1
		460					
KSS303_0490 MS3R050 CLM502U	56C	230	37	48.631	1,642	1,282	1.9
		460					
KSS403_0490 MS4R050 CLM502U	56C	230	37	48.944	1,652	2,055	2.9
		460					
KSS402_0460 MS4R050 CLM502U	56C	230	39	46.308	1,586	2,018	3.0
		460					

cLEAN System: GEARBOX & MOTOR

Part Number Codes	Compatible NEMA C-Frame ²⁾ with Designated Motor Adapter	Voltage	RPM Output	Ratio	Output Torque In. Lbs.	OHL (lbs)	Service Factor
1 HP Motor, 13 - 39 RPM Output (Approximate), 1800 RPM Input Continued							
KSS202_0460 MS2R050 CLM502U	56C	230	39	46.225	1,583	1,080	1.1
		460					
KSS302_0460 MS3R050 CLM502U	56C	230	39	46.225	1,583	1,260	1.9
		460					

1 HP Motor, 40 - 60 RPM Output (Approximate), 1800 RPM Input

KSS303_0450 MS3R050 CLM502U	56C	230	40	44.892	1,516	1,248	2.0
		460					
KSS403_0450 MS4R050 CLM502U	56C	230	40	44.536	1,504	1,992	3.2
		460					
KSS302_0410 MS3R050 CLM502U	56C	230	44	40.512	1,388	1,206	1.2
		460					
KSS402_0410 MS4R050 CLM502U	56C	230	44	40.512	1,388	1,930	2.0
		460					
KSS203_0390 MS2R050 CLM502U	56C	230	46	39.454	1,332	1,025	1.3
		460					
KSS303_0390 MS3R050 CLM502U	56C	230	46	39.187	1,323	1,193	2.3
		460					
KSS403_0390 MS4R050 CLM502U	56C	230	46	39.047	1,318	1,906	3.7
		460					
KSS402_0350 MS4R050 CLM502U	56C	230	52	34.758	1,191	1,834	4.1
		460					
KSS302_0350 MS3R050 CLM502U	56C	230	52	34.731	1,190	1,146	2.6
		460					
KSS202_0350 MS2R050 CLM502U	56C	230	52	34.554	1,184	980	1.5
		460					
KSS402_0340 MS4R050 CLM502U	56C	230	53	33.678	1,154	1,814	3.0
		460					
KSS202_0340 MS2R050 CLM502U	56C	230	54	33.618	1,152	971	1.2
		460					
KSS302_0340 MS3R050 CLM502U	56C	230	54	33.618	1,152	1,133	1.9
		460					
KSS303_0330 MS3R050 CLM502U	56C	230	55	32.649	1,102	1,122	2.8
		460					
KSS403_0320 MS4R050 CLM502U	56C	230	56	32.39	1,094	1,791	3.7
		460					
KSS403_0490 MS4R050 CLM502U	56C	460	61	48.944	990	1,733	4.9

Selection Data

IP68 and IP69K CERTIFIED



CLEAN System

Part Number Codes	Compatible NEMA C-Frame ²⁾ with Designated Motor Adapter	Voltage	RPM Output	Ratio	Output Torque In. Lbs.	OHL (lbs)	Service Factor
-------------------	---	---------	------------	-------	------------------------	-----------	----------------

1 HP Motor, 65 RPM Output (Approximate), 1800 RPM Input

KSS102_0280 MS1R050 CLM502U	56C	230	64	28.048	961	762	1.1
		460					
KSS202_0280 MS2R050 CLM502U	56C	230	64	27.95	957	913	1.8
		460					
KSS302_0280 MS3R050 CLM502U	56C	230	65	27.883	955	1,065	3.2
		460					
KSS402_0280 MS4R050 CLM502U	56C	230	65	27.771	951	1,701	5.1
		460					

1 HP Motor, 70 - 80 RPM Output (Approximate), 1800 RPM Input

KSS402_0250 MS4R050 CLM502U	56C	230	71	25.279	866	1,649	5.1
		460					
KSS302_0250 MS3R050 CLM502U	56C	230	71	25.259	865	1,030	3.5
		460					
KSS102_0250 MS1R050 CLM502U	56C	230	71	25.22	864	736	1.0
		460					
KSS202_0250 MS2R050 CLM502U	56C	230	72	25.13	861	882	2.1
		460					
KSS302_0230 MS3R050 CLM502U	56C	230	77	23.292	798	1,003	3.9
		460					
KSS102_0230 MS1R050 CLM502U	56C	230	77	23.265	797	716	1.3
		460					

1 HP Motor, 90 RPM Output (Approximate), 1800 RPM Input

KSS202_0200 MS2R050 CLM502U	56C	230	89	20.327	696	821	2.5
		460					
KSS302_0200 MS3R050 CLM502U	56C	230	89	20.278	695	958	4.5
		460					
KSS402_0200 MS4R050 CLM502U	56C	230	89	20.197	692	1,530	6.7
		460					
KSS102_0200 MS1R050 CLM502U	56C	230	89	20.15	690	683	1.4
		460					

1 HP Motor, 100 - 110 RPM Output (Approximate), 1800 RPM Input

KSS202_0175 MS2R050 CLM502U	56C	230	103	17.469	598	781	2.8
		460					
KSS402_0175 MS4R050 CLM502U	56C	230	103	17.405	596	1,456	7.4
		460					
KSS302_0175 MS3R050 CLM502U	56C	230	104	17.293	592	908	5.0
		460					

cLEAN System: GEARBOX & MOTOR

Part Number Codes	Compatible NEMA C-Frame ²⁾ with Designated Motor Adapter	Voltage	RPM Output	Ratio	Output Torque In. Lbs.	OHL (lbs)	Service Factor
-------------------	---	---------	------------	-------	------------------------	-----------	----------------

1 HP Motor, 100 - 110 RPM Output (Approximate), 1800 RPM Input Continued

KSS302_0170 MS3R050 CLM502U	56C	230	106	16.939	580	902	5.0
		460					
KSS102_0165 MS1R050 CLM502U	56C	230	108	16.714	573	641	1.6
		460					

1 HP Motor, 130 RPM Output (Approximate), 1800 RPM Input

KSS102_0140 MS1R050 CLM502U	56C	230	128	14.114	483	606	1.8
		460					
KSS302_0140 MS3R050 CLM502U	56C	230	129	13.935	477	845	5.7
		460					
KSS402_0140 MS4R050 CLM502U	56C	230	130	13.885	476	1,350	8.6
		460					
KSS202_0140 MS2R050 CLM502U	56C	230	130	13.851	474	723	3.3
		460					

1 HP Motor, 140 RPM Output (Approximate), 1800 RPM Input

KSS202_0125 MS2R050 CLM502U	56C	230	142	12.705	435	702	3.5
		460					
KSS402_0125 MS4R050 CLM502U	56C	230	142	12.658	434	1,309	9.2
		460					
KSS302_0125 MS3R050 CLM502U	56C	230	143	12.577	431	817	6.1
		460					

1 HP Motor, 155 RPM Output (Approximate), 1800 RPM Input

KSS302_0115 MS3R050 CLM502U	56C	230	155	11.61	398	795	6.5
		460					
KSS202_0115 MS2R050 CLM502U	56C	230	156	11.546	396	680	3.7
		460					
KSS402_0115 MS4R050 CLM502U	56C	230	156	11.518	395	1,269	9.4
		460					

1 HP Motor, 180 RPM Output (Approximate), 1800 RPM Input

KSS102_0100 MS1R050 CLM502U	56C	230	178	10.14	347	543	2.3
		460					
KSS302_0100 MS3R050 CLM502U	56C	230	178	10.135	347	760	7.1
		460					
KSS402_0100 MS4R050 CLM502U	56C	230	178	10.098	346	1,214	10.7
		460					
KSS202_0100 MS2R050 CLM502U	56C	230	179	10.073	345	650	4.1
		460					

Selection Data

IP68 and IP69K CERTIFIED



CLEAN System

Part Number Codes	Compatible NEMA C-Frame ²⁾ with Designated Motor Adapter	Voltage	RPM Output	Ratio	Output Torque In. Lbs.	OHL (lbs)	Service Factor
1 HP Motor, 195 RPM Output (Approximate), 1800 RPM Input							
KSS102_0092 MS1R050 CLM502U	56C	230	195	9.249	317	527	2.4
		460					
1 HP Motor, 215 RPM Output (Approximate), 1800 RPM Input							
KSS302_0084 MS3R050 CLM502U	56C	230	213	8.444	289	715	8.0
		460					
KSS202_0084 MS2R050 CLM502U	56C	230	214	8.397	288	612	4.6
		460					
KSS402_0084 MS4R050 CLM502U	56C	230	215	8.377	287	1,141	12.1
		460					
1 HP Motor, 245 - 275 RPM Output (Approximate), 1800 RPM Input							
KSS302_0074 MS3R050 CLM502U	56C	230	244	7.391	253	684	8.7
		460					
KSS202_0071 MS2R050 CLM502U	56C	230	253	7.118	244	579	5.1
		460					
KSS102_0066 MS1R050 CLM502U	56C	230	271	6.644	228	472	2.7
		460					
1 HP Motor, 320 - 450 RPM Output (Approximate), 1800 RPM Input							
KSS102_0056 MS1R050 CLM502U	56C	230	323	5.568	191	445	2.7
		460					
KSS302_0054 MS3R050 CLM502U	56C	230	335	5.375	184	615	10.8
		460					
KSS202_0052 MS2R050 CLM502U	56C	230	348	5.177	177	521	6.3
		460					
KSS102_0040 MS1R050 CLM502U	56C	230	450	4.000	137	398	2.7
		460					
KSS202_0040 MS2R050 CLM502U	56C	230	450	4.000	137	478	7.5
		460					
1 HP Motor, 13 - 40 RPM Output (Approximate), 3,000 RPM Input							
KSS403_1790 MS4R050 CLM502U	56C	460	17	179.056	3,621	2,518	1.3
KSS403_1340 MS4R050 CLM502U	56C	460	22	134.399	2,718	2,427	1.8
KSS303_1080 MS3R050 CLM502U	56C	460	28	107.814	2,180	1,410	1.4
KSS403_1070 MS4R050 CLM502U	56C	460	28	107.381	2,172	2,252	2.2
KSS303_0900 MS3R050 CLM502U	56C	460	33	90.061	1,821	1,328	1.7
KSS203_0800 MS2R050 CLM502U	56C	460	38	79.615	1,610	1,092	1.1
KSS303_0780 MS3R050 CLM502U	56C	460	38	78.41	1,586	1,268	2.0
KSS403_0780 MS4R050 CLM502U	56C	460	38	78.095	1,579	2,026	3.1

cLEAN System: GEARBOX & MOTOR

Part Number Codes	Compatible NEMA C-Frame ²⁾ with Designated Motor Adapter	Voltage	RPM Output	Ratio	Output Torque In. Lbs.	OHL (lbs)	Service Factor
1 HP Motor, 40 - 70 RPM Output (Approximate), 3,000 RPM Input							
KSS203_0680 MS2R050 CLM502U	56C	460	44	68.419	1,384	1,038	1.3
KSS303_0650 MS3R050 CLM502U	56C	460	46	65.499	1,325	1,194	2.3
KSS302_0560 MS3R050 CLM502U	56C	460	54	55.705	1,143	1,131	2.1
KSS402_0560 MS4R050 CLM502U	56C	460	54	55.705	1,143	1,810	3.3
KSS203_0540 MS2R050 CLM502U	56C	460	55	54.25	1,097	961	1.6
KSS303_0540 MS3R050 CLM502U	56C	460	56	53.883	1,090	1,119	2.8
KSS403_0540 MS4R050 CLM502U	56C	460	56	53.69	1,086	1,788	4.5
KSS402_0460 MS4R050 CLM502U	56C	460	65	46.308	950	1,702	5.0
KSS303_0450 MS3R050 CLM502U	56C	460	67	44.892	908	1,053	3.4
KSS403_0450 MS4R050 CLM502U	56C	460	67	44.536	901	1,680	5.4

1 HP Motor, 75 - 95 RPM Output (Approximate), 3,000 RPM Input

KSS302_0410 MS3R050 CLM502U	56C	460	74	40.512	831	1,017	2.1
KSS402_0410 MS4R050 CLM502U	56C	460	74	40.512	831	1,628	3.3
KSS203_0390 MS2R050 CLM502U	56C	460	76	39.454	798	864	2.2
KSS303_0390 MS3R050 CLM502U	56C	460	77	39.187	792	1,006	3.9
KSS403_0390 MS4R050 CLM502U	56C	460	77	39.047	790	1,608	6.2
KSS102_0350 MS1R050 CLM502U	56C	460	85	35.105	720	693	1.5
KSS402_0350 MS4R050 CLM502U	56C	460	86	34.758	713	1,547	6.8
KSS402_0340 MS4R050 CLM502U	56C	460	89	33.678	691	1,530	5.0
KSS303_0330 MS3R050 CLM502U	56C	460	92	32.649	660	947	4.7
KSS403_0320 MS4R050 CLM502U	56C	460	93	32.39	655	1,511	6.2

1 HP Motor, 100 - 300 RPM Output (Approximate), 3,000 RPM Input Continued Next Page

KSS102_0280 MS1R050 CLM502U	56C	460	107	28.048	576	643	1.8
KSS202_0280 MS2R050 CLM502U	56C	460	107	27.95	574	770	3.1
KSS302_0280 MS3R050 CLM502U	56C	460	108	27.883	572	898	5.4
KSS402_0250 MS4R050 CLM502U	56C	460	119	25.279	519	1,391	8.5
KSS302_0230 MS3R050 CLM502U	56C	460	129	23.292	478	846	6.5
KSS202_0200 MS2R050 CLM502U	56C	460	148	20.327	417	693	4.2
KSS302_0200 MS3R050 CLM502U	56C	460	148	20.278	416	808	7.4
KSS202_0175 MS2R050 CLM502U	56C	460	172	17.469	358	659	4.7
KSS402_0175 MS4R050 CLM502U	56C	460	172	17.405	357	1,228	12.4
KSS302_0170 MS3R050 CLM502U	56C	460	177	16.939	348	761	8.4
KSS102_0165 MS1R050 CLM502U	56C	460	179	16.714	343	541	2.7
KSS102_0140 MS1R050 CLM502U	56C	460	213	14.114	290	511	3.0
KSS302_0140 MS3R050 CLM502U	56C	460	215	13.935	286	713	9.6
KSS202_0125 MS2R050 CLM502U	56C	460	236	12.705	261	592	5.8

Selection Data

IP68 and IP69K CERTIFIED



CLEAN System

Part Number Codes	Compatible NEMA C-Frame ²⁾ with Designated Motor Adapter	Voltage	RPM Output	Ratio	Output Torque In. Lbs.	OHL (lbs)	Service Factor
-------------------	---	---------	------------	-------	------------------------	-----------	----------------

1 HP Motor, 100 - 300 RPM Output (Approximate), 3,000 RPM Input Continued

KSS302_0115 MS3R050 CLM502U*	56C	460	258	11.61	238	671	10.8
KSS102_0100 MS1R050 CLM502U	56C	460	296	10.14	208	458	3.8
KSS302_0100 MS3R050 CLM502U	56C	460	296	10.135	208	641	11.8

1 HP Motor, 325 - 750 RPM Output (Approximate), 3,000 RPM Input

KSS102_0092 MS1R050 CLM502U	56C	460	324	9.249	190	444	4.0
KSS302_0084 MS3R050 CLM502U*	56C	460	355	8.444	173	603	13.4
KSS202_0071 MS2R050 CLM502U*	56C	460	421	7.118	146	488	8.5
KSS102_0066 MS1R050 CLM502U	56C	460	452	6.644	136	398	4.4
KSS102_0056 MS1R050 CLM502U*	56C	460	539	5.568	114	375	4.4
KSS202_0052 MS2R050 CLM502U*	56C	460	579	5.177	106	439	10.6
KSS102_0040 MS1R050 CLM502U*	56C	460	750	4.000	82	336	4.4
KSS202_0040 MS2R050 CLM502U*	56C	460	750	4.000	82	403	12.5

2 HP Motor, 20 - 40 RPM Output (Approximate), 1,800 RPM Input

KSS402_0560 MS4R140 CLM503U	143/145TC	230	32	55.705	3,812	2,146	1.0
		460					
KSS403_0540 MS4R140 CLM503U	143/145TC	230	34	53.69	3,621	2,120	1.3
		460					
KSS403_0490 MS4R140 CLM503U	143/145TC	230	37	48.944	3,300	2,055	1.4
		460					
KSS402_0460 MS4R140 CLM503U	143/145TC	230	39	46.308	3,169	2,018	1.5
		460					
KSS302_0460 MS3R140 CLM503U	143/145TC	230	39	46.225	3,163	1,260	1.0
		460					
KSS303_0450 MS3R140 CLM503U	143/145TC	230	40	44.892	3,027	1,248	1.0
		460					
KSS403_0450 MS4R140 CLM503U	143/145TC	230	40	44.536	3,003	1,992	1.6
		460					

2 HP Motor, 45 - 60 RPM Output (Approximate), 1,800 RPM Input

KSS402_0410 MS4R140 CLM503U	143/145TC	230	44	40.512	2,772	1,930	1.0
		460					
KSS303_0390 MS3R140 CLM503U	143/145TC	230	46	39.187	2,643	1,193	1.2
		460					
KSS403_0390 MS4R140 CLM503U	143/145TC	230	46	39.047	2,633	1,906	1.8
		460					
KSS402_0350 MS4R140 CLM503U	143/145TC	230	52	34.758	2,378	1,834	2.0
		460					

*Max continuous speed is less than 3,000RPM. Contact STÖBER about max operating speeds.

cLEAN System: GEARBOX & MOTOR

Part Number Codes	Compatible NEMA C-Frame ²⁾ with Designated Motor Adapter	Voltage	RPM Output	Ratio	Output Torque In. Lbs.	OHL (lbs)	Service Factor
2 HP Motor, 45 - 60 RPM Output (Approximate), 1,800 RPM Input Continued							
KSS302_0350 MS3R140 CLM503U	143/145TC	230	52	34.731	2,377	1,146	1.3
		460					
KSS402_0340 MS4R140 CLM503U	143/145TC	230	53	33.678	2,304	1,814	1.5
		460					
KSS302_0340 MS3R140 CLM503U	143/145TC	230	54	33.618	2,300	1,133	1.0
		460					
KSS303_0330 MS3R140 CLM503U	143/145TC	230	55	32.649	2,202	1,122	1.4
		460					
KSS403_0320 MS4R140 CLM503U	143/145TC	230	56	32.39	2,184	1,791	1.9
		460					
KSS403_0490 MS4R140 CLM503U	143/145TC	460	61	48.944	1,979	1,733	2.4
2 HP Motor, 65 - 90 RPM Output (Approximate), 1,800 RPM Input							
KSS302_0280 MS3R140 CLM503U	143/145TC	230	65	27.883	1,908	1,065	1.6
		460					
KSS402_0280 MS4R140 CLM503U	143/145TC	230	65	27.771	1,900	1,701	2.6
		460					
KSS402_0250 MS4R140 CLM503U	143/145TC	230	71	25.279	1,730	1,649	2.6
		460					
KSS302_0250 MS3R140 CLM503U	143/145TC	230	71	25.259	1,728	1,030	1.8
		460					
KSS202_0250 MS2R140 CLM503U	143/145TC	230	72	25.13	1,720	882	1.0
		460					
KSS302_0230 MS3R140 CLM503U	143/145TC	230	77	23.292	1,594	1,003	1.9
		460					
KSS202_0200 MS2R140 CLM503U	143/145TC	230	89	20.327	1,391	821	1.3
		460					
KSS302_0200 MS3R140 CLM503U	143/145TC	230	89	20.278	1,388	958	2.2
		460					
KSS402_0200 MS4R140 CLM503U	143/145TC	230	89	20.197	1,382	1,530	3.4
		460					
2 HP Motor, 100 - 110 RPM Output (Approximate), 1,800 RPM Input							
KSS202_0175 MS2R140 CLM503U	143/145TC	230	103	17.469	1,195	781	1.4
		460					
KSS402_0175 MS4R140 CLM503U	143/145TC	230	103	17.405	1,191	1,456	3.7
		460					
KSS302_0175 MS3R140 CLM503U	143/145TC	230	104	17.293	1,183	908	2.5
		460					

IP68 and IP69K CERTIFIED



CLEAN System

Part Number Codes	Compatible NEMA C-Frame ²⁾ with Designated Motor Adapter	Voltage	RPM Output	Ratio	Output Torque In. Lbs.	OHL (lbs)	Service Factor
2 HP Motor, 100 - 110 RPM Output (Approximate), 1,800 RPM Input Continued							
KSS302_0170 MS3R140 CLM503U	143/145TC	230	106	16.939	1,159	902	2.5
		460					
2 HP Motor, 130 - 150 RPM Output (Approximate), 1,800 RPM Input							
KSS302_0140 MS3R140 CLM503U	143/145TC	230	129	13.935	954	845	2.9
		460					
KSS402_0140 MS4R140 CLM503U	143/145TC	230	130	13.885	950	1,350	4.3
		460					
KSS202_0140 MS2R140 CLM503U	143/145TC	230	130	13.851	948	723	1.6
		460					
KSS202_0125 MS2R140 CLM503U	143/145TC	230	142	12.705	869	702	1.7
		460					
KSS402_0125 MS4R140 CLM503U	143/145TC	230	142	12.658	866	1,309	4.6
		460					
KSS302_0125 MS3R140 CLM503U	143/145TC	230	143	12.577	861	817	3.1
		460					
2 HP Motor, 155 - 180 RPM Output (Approximate), 1,800 RPM Input							
KSS302_0115 MS3R140 CLM503U	143/145TC	230	155	11.61	794	795	3.2
		460					
KSS202_0115 MS2R140 CLM503U	143/145TC	230	156	11.546	790	680	1.9
		460					
KSS402_0115 MS4R140 CLM503U	143/145TC	230	156	11.518	788	1,269	4.7
		460					4.9
KSS302_0100 MS3R140 CLM503U	143/145TC	230	178	10.135	694	760	3.5
		460					
KSS402_0100 MS4R140 CLM503U	143/145TC	230	178	10.098	691	1,214	4.7
		460					5.3
KSS202_0100 MS2R140 CLM503U	143/145TC	230	179	10.073	689	650	2.0
		460					

cLEAN System: GEARBOX & MOTOR

Part Number Codes	Compatible NEMA C-Frame ²⁾ with Designated Motor Adapter	Voltage	RPM Output	Ratio	Output Torque In. Lbs.	OHL (lbs)	Service Factor
2 HP Motor, 210 - 260 RPM Output (Approximate), 1,800 RPM Input							
KSS302_0084 MS3R140 CLM503U	143/145TC	230	213	8.444	578	715	4.0
		460					
KSS202_0084 MS2R140 CLM503U	143/145TC	230	214	8.397	575	612	2.3
		460					
KSS402_0084 MS4R140 CLM503U	143/145TC	230	215	8.377	573	1,141	6.0
		460					4.7
KSS302_0074 MS3R140 CLM503U	143/145TC	230	244	7.391	506	684	6.0
		460					4.4
KSS202_0071 MS2R140 CLM503U	143/145TC	230	253	7.118	487	579	2.6
		460					
2 HP Motor, 330 - 450 RPM Output (Approximate), 1,800 RPM Input							
KSS302_0054 MS3R140 CLM503U	143/145TC	230	335	5.375	368	615	5.4
		460					
KSS202_0052 MS2R140 CLM503U	143/145TC	230	348	5.177	354	521	3.2
		460					
KSS202_0040 MS2R140 CLM503U	143/145TC	230	450	4.000	274	478	3.8
		460					
KSS302_0040 MS3R140 CLM503U	143/145TC	230	450	4.000	274	557	6.6
		460					
2 HP Motor, 20 - 40 RPM Output (Approximate), 3,000 RPM Input							
KSS403_1070 MS4R140 CLM503U	143/145TC	460	28	107.381	4,343	2,252	1.1
KSS303_0780 MS3R140 CLM503U	143/145TC	460	38	78.41	3,171	1,268	1.0
KSS403_0780 MS4R140 CLM503U	143/145TC	460	38	78.095	3,159	2,026	1.5
2 HP Motor, 45 - 80 RPM Output (Approximate), 3,000 RPM Input							
KSS303_0650 MS3R140 CLM503U	143/145TC	460	46	65.499	2,649	1,194	1.2
KSS302_0560 MS3R140 CLM503U	143/145TC	460	54	55.705	2,286	1,131	1.0
KSS402_0560 MS4R140 CLM503U	143/145TC	460	54	55.705	2,286	1,810	1.6
KSS303_0540 MS3R140 CLM503U	143/145TC	460	56	53.883	2,179	1,119	1.4
KSS403_0540 MS4R140 CLM503U	143/145TC	460	56	53.69	2,172	1,788	2.2
KSS402_0460 MS4R140 CLM503U	143/145TC	460	65	46.308	1,900	1,702	2.5
KSS303_0450 MS3R140 CLM503U	143/145TC	460	67	44.892	1,816	1,053	1.7
KSS403_0450 MS4R140 CLM503U	143/145TC	460	67	44.536	1,801	1,680	2.7
KSS302_0410 MS3R140 CLM503U	143/145TC	460	74	40.512	1,663	1,017	1.0

IP68 and IP69K CERTIFIED



CLEAN System

Part Number Codes	Compatible NEMA C-Frame ²⁾ with Designated Motor Adapter	Voltage	RPM Output	Ratio	Output Torque In. Lbs.	OHL (lbs)	Service Factor
-------------------	---	---------	------------	-------	------------------------	-----------	----------------

2 HP Motor, 45 - 80 RPM Output (Approximate), 3,000 RPM Input Continued

KSS402_0410 MS4R140 CLM503U	143/145TC	460	74	40.512	1,663	1,628	1.6
KSS303_0390 MS3R140 CLM503U	143/145TC	460	77	39.187	1,585	1,006	2.0
KSS403_0390 MS4R140 CLM503U	143/145TC	460	77	39.047	1,579	1,608	3.1

2 HP Motor, 85 - 180 RPM Output (Approximate), 3,000 RPM Input

KSS402_0350 MS4R140 CLM503U	143/145TC	460	86	34.758	1,426	1,547	3.4
KSS402_0340 MS4R140 CLM503U	143/145TC	460	89	33.678	1,382	1,530	2.5
KSS303_0330 MS3R140 CLM503U	143/145TC	460	92	32.649	1,321	947	2.3
KSS403_0320 MS4R140 CLM503U	143/145TC	460	93	32.39	1,310	1,511	3.1
KSS202_0280 MS2R140 CLM503U	143/145TC	460	107	27.95	1,147	770	1.5
KSS302_0280 MS3R140 CLM503U	143/145TC	460	108	27.883	1,144	898	2.7
KSS402_0280 MS4R140 CLM503U	143/145TC	460	108	27.771	1,140	1,435	4.3
KSS402_0250 MS4R140 CLM503U	143/145TC	460	119	25.279	1,037	1,391	4.3
KSS302_0230 MS3R140 CLM503U	143/145TC	460	129	23.292	956	846	3.2
KSS202_0200 MS2R140 CLM503U	143/145TC	460	148	20.327	834	693	2.1
KSS302_0200 MS3R140 CLM503U	143/145TC	460	148	20.278	832	808	3.7
KSS402_0200 MS4R140 CLM503U	143/145TC	460	149	20.197	829	1,291	5.6
KSS202_0175 MS2R140 CLM503U	143/145TC	460	172	17.469	717	659	2.3
KSS402_0175 MS4R140 CLM503U	143/145TC	460	172	17.405	714	1,228	6.2
KSS302_0170 MS3R140 CLM503U	143/145TC	460	177	16.939	695	761	4.2

2 HP Motor, 215 - 580 RPM Output (Approximate), 3,000 RPM Input

KSS302_0140 MS3R140 CLM503U	143/145TC	460	215	13.935	572	713	4.8
KSS402_0140 MS4R140 CLM503U	143/145TC	460	216	13.885	570	1,139	7.2
KSS202_0125 MS2R140 CLM503U	143/145TC	460	236	12.705	521	592	2.9
KSS402_0125 MS4R140 CLM503U	143/145TC	460	237	12.658	519	1,104	7.6
KSS302_0115 MS3R140 CLM503U*	143/145TC	460	258	11.61	476	671	5.4
KSS302_0100 MS3R140 CLM503U	143/145TC	460	296	10.135	416	641	5.9
KSS302_0084 MS3R140 CLM503U*	143/145TC	460	355	8.444	347	603	6.7
KSS202_0071 MS2R140 CLM503U*	143/145TC	460	421	7.118	292	488	4.3
KSS202_0052 MS2R140 CLM503U*	143/145TC	460	579	5.177	212	439	5.3
KSS202_0040 MS2R140 CLM503U*	143/145TC	460	750	4.000	164	403	6.3

*Max continuous speed is less than 3,000RPM. Contact STÖBER about max operating speeds.

cLEAN System: GEARBOX & MOTOR

Part Number Codes	Compatible NEMA C-Frame ²⁾ with Designated Motor Adapter	Voltage	RPM Output	Ratio	Output Torque In. Lbs.	OHL (lbs)	Service Factor
-------------------	---	---------	------------	-------	------------------------	-----------	----------------

3 HP Motor, 40 - 70 RPM Output (Approximate), 1800 RPM

KSS402_0460 MS4R180 CLM505U	182/184TC	230	39	46.308	4683	2018	1.0
		460					
KSS402_0350 MS4R180 CLM505U	182/184TC	230	52	34.758	3515	1834	1.4
		460					
KSS402_0340 MS4R180 CLM505U	182/184TC	230	53	33.678	3406	1814	1.0
		460					
KSS302_0280 MS3R180 CLM505U	182/184TC	230	65	27.883	2820	1065	1.1
		460					
KSS402_0280 MS4R180 CLM505U	182/184TC	230	65	27.771	2808	1701	1.7
		460					

3 HP Motor, 70 - 80 RPM Output (Approximate), 1800 RPM

KSS402_0250 MS4R180 CLM505U	182/184TC	230	71	25.279	2556	1649	1.7
		460					
KSS302_0250 MS3R180 CLM505U	182/184TC	230	71	25.259	2554	1030	1.2
		460					
KSS302_0230 MS3R180 CLM505U	182/184TC	230	77	23.292	2355	1003	1.3
		460					

3 HP Motor, 90 - 110 RPM Output (Approximate), 1800 RPM

KSS402_0200 MS4R180 CLM505U	182/184TC	230	89	20.197	2042	1530	2.2
		460					
KSS302_0200 MS3R180 CLM505U	182/184TC	230	89	20.278	2051	958	1.4
		460					
KSS402_0175 MS4R180 CLM505U	182/184TC	230	103	17.405	1760	1456	2.4
		460					
KSS302_0175 MS3R180 CLM505U	182/184TC	230	104	17.293	1749	908	1.6
		460					
KSS302_0170 MS3R180 CLM505U	182/184TC	230	106	16.939	1713	902	1.6
		460					

IP68 and IP69K CERTIFIED

CLEAN System

Part Number Codes	Compatible NEMA C-Frame ²⁾ with Designated Motor Adapter	Voltage	RPM Output	Ratio	Output Torque In. Lbs.	OHL (lbs)	Service Factor
-------------------	---	---------	------------	-------	------------------------	-----------	----------------

3 HP Motor, 130 - 145 RPM Output (Approximate), 1800 RPM

KSS402_0140 MS4R180 CLM505U	182/184TC	230	130	13.885	1404	1350	2.8
		460					
KSS302_0140 MS3R180 CLM505U	182/184TC	230	129	13.935	1409	845	1.8
		460					
KSS202_0140 MS2R140 CLM505U	143/145TC	230	130	13.851	1401	723	1.1
		460					
KSS402_0125 MS4R180 CLM505U	182/184TC	230	142	12.658	1280	1309	2.9
		460					
KSS302_0125 MS3R180 CLM505U	182/184TC	230	143	12.577	1272	817	2.0
		460					
KSS202_0125 MS2R140 CLM505U	143/145TC	230	142	12.705	1285	702	1.1
		460					

3 HP Motor, 155 - 160 RPM Output (Approximate), 1800 RPM

KSS402_0115 MS4R180 CLM505U	182/184TC	230	156	11.518	1165	1269	3.1
		460					
KSS302_0115 MS3R180 CLM505U	182/184TC	230	155	11.61	1174	795	2.1
		460					
KSS202_0115 MS2R140 CLM505U	143/145TC	230	156	11.546	1168	680	1.2
		460					

3 HP Motor, 178 RPM Output (Approximate), 1800 RPM

KSS402_0100 MS4R180 CLM505U	182/184TC	230	178	10.098	1021	1214	3.2
		460					
KSS302_0100 MS3R180 CLM505U	182/184TC	230	178	10.135	1025	760	2.3
		460					
KSS202_0100 MS2R140 CLM505U	143/145TC	230	179	10.073	1019	650	1.3
		460					

3 HP Motor, 210 - 215 RPM Output (Approximate), 1800 RPM

KSS302_0084 MS3R180 CLM505U	182/184TC	230	213	8.444	854	715	2.6
		460					
KSS202_0084 MS2R140 CLM505U	143/145TC	230	214	8.397	849	612	1.5
		460					
KSS402_0084 MS4R180 CLM505U	182/184TC	230	215	8.377	847	1141	3.2
		460					

cLEAN System: GEARBOX & MOTOR

Part Number Codes	Compatible NEMA C-Frame ²⁾ with Designated Motor Adapter	Voltage	RPM Output	Ratio	Output Torque In. Lbs.	OHL (lbs)	Service Factor
-------------------	---	---------	------------	-------	------------------------	-----------	----------------

3 HP Motor, 240 - 255 RPM Output (Approximate), 1800 RPM

KSS402_0075 MS4R180 CLM505U	182/184TC	230	241	7.456	754	1098	3.2
		460					
KSS302_0074 MS3R180 CLM505U	182/184TC	230	244	7.391	747	684	2.8
		460					
KSS202_0071 MS2R140 CLM505U	143/145TC	230	253	7.118	720	579	1.6
		460					

3 HP Motor, 330 - 350 RPM Output (Approximate), 1800 RPM

KSS402_0054 MS4R180 CLM505U	182/184TC	230	332	5.422	548	987	3.2
		460					
KSS302_0054 MS3R180 CLM505U	182/184TC	230	335	5.375	544	615	3.5
		460					
KSS202_0052 MS2R140 CLM505U	143/145TC	230	348	5.177	524	521	2.0
		460					

3 HP Motor, 450 RPM Output (Approximate), 1800 RPM

KSS402_0040 MS4R180 CLM505U	182/184TC	230	450	4	404	892	3.2
		460					
KSS302_0040 MS3R180 CLM505U	182/184TC	230	450	4	404	557	4.2
		460					
KSS202_0040 MS2R140 CLM505U	143/145TC	230	450	4	404	478	2.4
		460					

3 HP Motor, 50 - 70 RPM Output (Approximately), 3000 RPM Input

KSS402_0560 MS4R180 CLM505U	182/184TC	460	54	55.705	3438	1810	1.1
KSS402_0460 MS4R180 CLM505U	182/184TC	460	65	46.308	2858	1702	1.7
KSS302_0460 MS3R180 CLM505U	182/184TC	460	65	46.225	2853	1063	1.1

3 HP Motor, 70 - 90 RPM Output (Approximately), 3000 RPM Input

KSS402_0410 MS4R180 CLM505U	182/184TC	460	74	40.512	2501	1628	1.1
KSS402_0350 MS4R180 CLM505U	182/184TC	460	86	34.758	2145	1547	2.1
KSS302_0350 MS3R180 CLM505U	182/184TC	460	86	34.731	2144	966	1.4
KSS402_0340 MS4R180 CLM505U	182/184TC	460	89	33.678	2079	1530	1.7
KSS302_0340 MS3R180 CLM505U	182/184TC	460	89	33.618	2075	956	1.1

3 HP Motor, 90 - 130 RPM Output (Approximately), 3000 RPM Input

KSS302_0280 MS3R180 CLM505U	182/184TC	460	108	27.883	1721	898	1.6
KSS402_0280 MS4R180 CLM505U	182/184TC	460	108	27.771	1714	1435	2.4
KSS402_0250 MS4R180 CLM505U	182/184TC	460	119	25.279	1560	1391	2.5
KSS302_0250 MS3R180 CLM505U	182/184TC	460	119	25.259	1559	869	1.7
KSS302_0230 MS3R180 CLM505U	182/184TC	460	129	23.292	1438	846	1.8

IP68 and IP69K CERTIFIED

CLEAN System

Part Number Codes	Compatible NEMA C-Frame ²⁾ with Designated Motor Adapter	Voltage	RPM Output	Ratio	Output Torque In. Lbs.	OHL (lbs)	Service Factor
-------------------	---	---------	------------	-------	------------------------	-----------	----------------

3 HP Motor, 150 RPM Output (Approxiamately), 3000 RPM Input

KSS202_0200 MS2R140 CLM505U	143/145TC	460	148	20.327	1255	693	1.1
KSS302_0200 MS3R180 CLM505U	182/184TC	460	148	20.278	1252	808	2.0
KSS402_0200 MS4R180 CLM505U	182/184TC	460	149	20.197	1247	1291	3.0

3 HP Motor, 170 - 180 RPM Output (Approxiamately), 3000 RPM Input

KSS202_0175 MS2R140 CLM505U	143/145TC	460	172	17.469	1078	659	1.2
KSS402_0175 MS4R180 CLM505U	182/184TC	460	172	17.405	1074	1228	3.3
KSS302_0175 MS3R180 CLM505U	182/184TC	460	173	17.293	1067	766	2.2
KSS302_0170 MS3R180 CLM505U	182/184TC	460	177	16.939	1046	761	2.2

3 HP Motor, 215 - 240 RPM Output (Approxiamately), 3000 RPM Input

KSS302_0140 MS3R180 CLM505U	182/184TC	460	215	13.935	860	713	2.5
KSS402_0140 MS4R180 CLM505U	182/184TC	460	216	13.885	857	1139	3.8
KSS202_0140 MS2R140 CLM505U	143/145TC	460	217	13.851	855	610	1.4
KSS202_0125 MS2R140 CLM505U	143/145TC	460	236	12.705	784	592	1.5
KSS402_0125 MS4R180 CLM505U	182/184TC	460	237	12.658	781	1104	4.0
KSS302_0125 MS3R180 CLM505U	182/184TC	460	239	12.577	776	689	2.7

3 HP Motor, 260 - 300 RPM Output (Approxiamately), 3000 RPM Input

KSS202_0115 MS2R140 CLM505U	143/145TC	460	260	11.546	713	574	1.6
KSS302_0100 MS3R180 CLM505U	182/184TC	460	296	10.135	626	641	3.1
KSS402_0100 MS4R180 CLM505U	182/184TC	460	297	10.098	623	1024	4.7
KSS202_0100 MS2R140 CLM505U	143/145TC	460	298	10.073	622	548	1.8

3 HP Motor, 360 RPM Output (Approxiamately), 3000 RPM Input

KSS202_0084 MS2R140 CLM505U	143/145TC	460	357	8.397	518	516	2.0
-----------------------------	-----------	-----	-----	-------	-----	-----	-----

“W” Double Bushing Output with “G” Pilot Circle Diameter (PCD) Tapped Holes

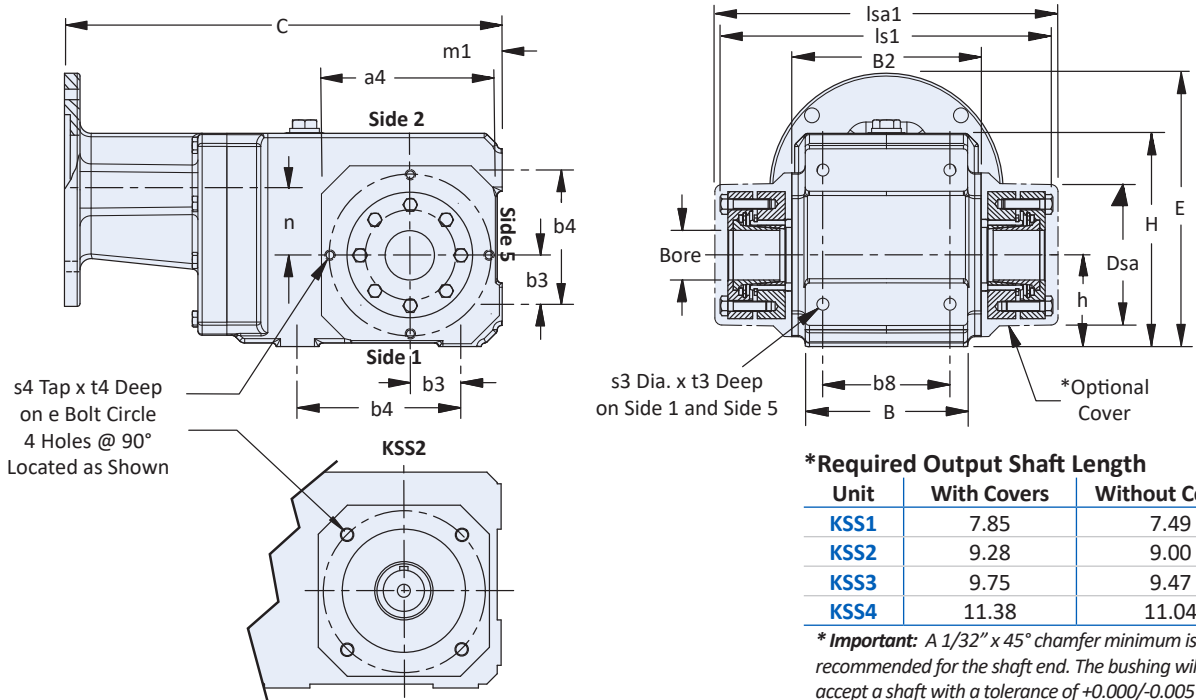

Table 1 KSS Series – “W” Double Wobble-Free Bushing Output with “G” Pilot Circle Diameter (PCD) Tapped Holes – Dimensions (in)

Base Module	a4	B2	b3	b4	b7	b8	Dsa	e	H	h	ls1	lsa1	m1	s3	s4	t3	t4
KSS1	4.53	4.17	1.18	3.54	2.95	2.76	3.07	3.54	4.96	2.36	7.64	7.80	2.36	M8x1.25	M8x1.25	0.51	0.51
KSS2	4.57	5.28	1.38	4.53	3.74	3.54	3.92	4.53	5.94	2.56	8.90	9.36	2.56	M10x1.50	M8x1.25	0.63	0.51
KSS3	5.20	5.75	1.38	5.12	4.13	4.13	3.78	4.53	6.56	2.95	9.41	9.95	2.95	M10x1.50	M8x1.25	0.63	0.55
KSS4	5.99	6.81	1.97	6.10	5.00	4.72	4.33	5.12	7.89	3.54	11.06	11.60	3.54	M12x1.75	M10x1.5	0.75	0.63

Table 2 KSS Series – “WG” Style Motor Adapter Dimensions (in)

Base Module	NEMA C-Face	B	C	E	n	Wt. lbs
KSS102WG_MS1R050	56C	3.54	10.55	7.03	1.42	29
KSS202WG_MS2R050	56C	4.41	12.20	7.62	1.81	40
KSS202WG_MS2R140	143/145TC					
KSS203WG_MS2R050	56C	4.53	13.07	6.64	0.83	53
KSS302WG_MS3R050	56C		13.23		2.09	55
KSS302WG_MS3R140	143/145TC	5.51	13.23	8.29	2.09	55
KSS302WG_MS3R180	182/184TC		14.57		2.07	67
KSS303WG_MS3R050	56C	5.51	15.22	6.83	0.63	55
KSS303WG_MS3R140	143/145TC					
KSS402WG_MS4R050	56C		14.76	9.96		84
KSS402WG_MS4R140	143/145TC	5.71	14.76	9.96	2.36	84
KSS402WG_MS4R180	182/184TC		15.79	10.91		89
KSS403WG_MS4R050	56C	5.71	16.46	8.39	0.98	94
KSS403WG_MS4R140	143/145TC					

Table 3 “WFBSS” Double Side Bushings Stock Bore Sizes

Base Module	Inches						Metric – mm
	1	1-3/16	1-1/4	1-3/8	1-7/16	1-1/2	40
KSS1	WFBSS1-100	—	—	—	—	—	—
KSS2	WFBSS2-100	WFBSS2-103	WFBSS2-104	WFBSS2-106	WFBSS2-107	WFBSS2-108	—
KSS3	WFBSS3-100	WFBSS3-103	WFBSS3-104	WFBSS3-106	WFBSS3-107	WFBSS3-108	—
KSS4	—	—	WFBSS4-104	—	WFBSS4-107	WFBSS4-108	—



“W” Double Bushing Output with “GD” Torque Arm Bracket

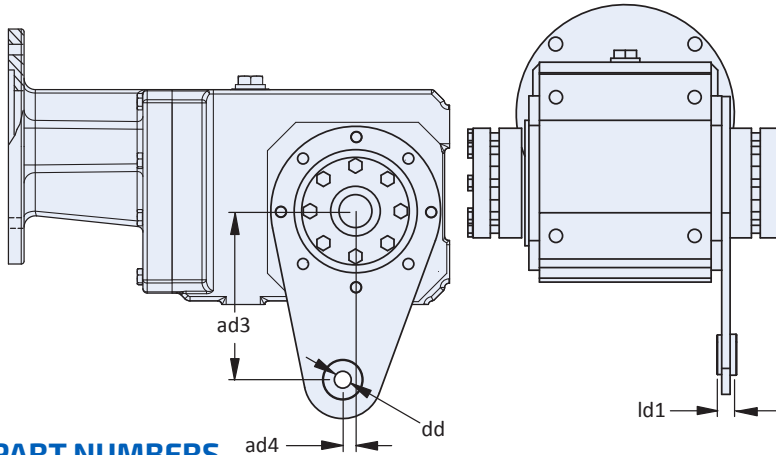

Table 4 “GD” Torque Arm

Base Module	Kit Number	mm			
		ad3	ad4	dd	ld1
KSS1	CS213227	130	10	13	15
KSS2	CS129573	130	10	13	15
KSS3	CS129573	130	10	13	15
KSS4	CS139679	130	10	13	15

Note: a bushing output plastic cover cannot be used on the Torque Arm side of speed reducer. A plastic cover can only be used on the side opposite the torque arm.

KIT PART NUMBERS

- CS137450 (205/206 Flanged Bearing)
- CS137367 (207/208 Flanged Bearing)

Required Shaft Lengths Wobble Free Bushing Length

Unit/Flange Bearing	205/206	207/208
KSS1	10.20	-
KSS2	11.4	11.94
KSS3	10.87	12.42
KSS4	13.19	13.73

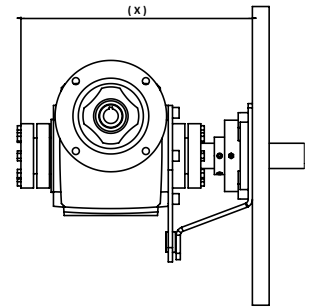

For the N-W CLM503 145TC, please change the 1.98 to 2.25.
Also please put a space between the CLM505 145TC.

cLEAN Motor Straight or Right Angle Cable Gland Option

Table 5 cLEAN Motor Dimensions (in)

Base Module	AG	AG1	AJ	BE	BF Tap Size	ES	N-W	P	U
CLM502 050	9.08	10.53	5.875	1.19	3/8-16	1.5	1.875	5.5	5/8
CLM503 050	10.38	11.84	5.875	1.19	3/8-16	1.5	1.875	5.5	5/8
CLM503 140	10.58	11.84	5.875	1.19	3/8-16	2.0	2.25	5.5	7/8
CLM505 140	13.14	14.59	5.875	1.19	3/8-16	2.0	2.25	5.5	7/8
CLM505 180	13.38	14.83	7.25	1.41	1/2-13	2.0	2.75	5.5	1-1/8

*AG is overall length of motor housing for straight options.
*AG1 is overall length of motor housing for right angle options.

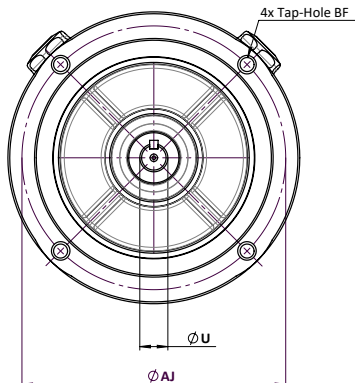
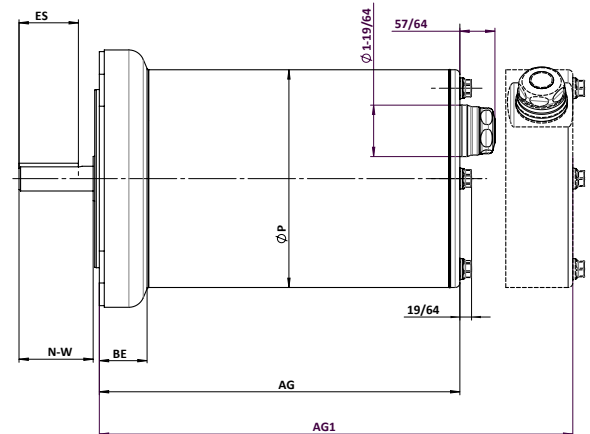

cLEAN Motor Straight Cable Gland

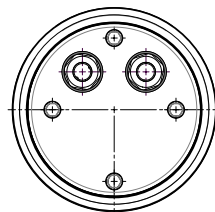

Resolver option has two cables.

cLEAN Motor Right Angle Cable Gland

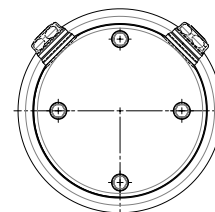

Resolver option has two cables.

Brake is only available in right angle cable gland configuration.

"A" Hollow Bore Output with "G" Pilot Circle Diameter (PCD) Tapped Holes

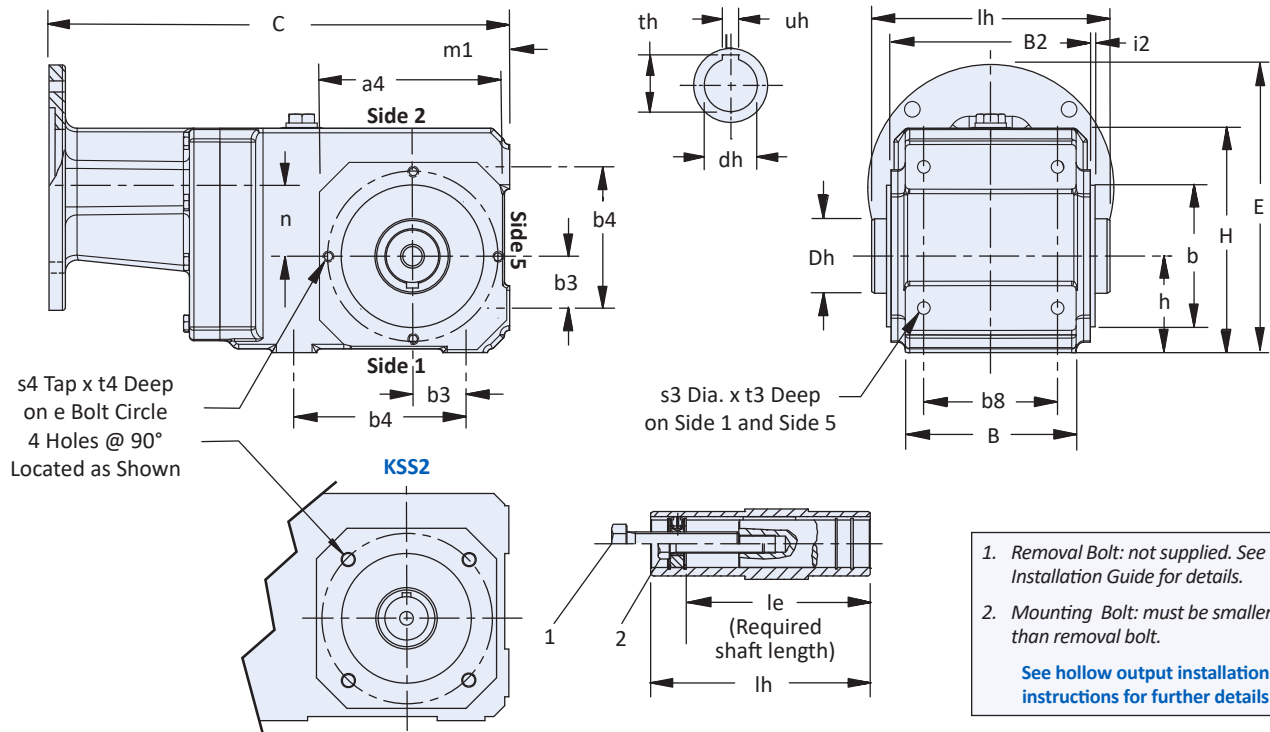

Table 1 KSS Series – "A" Hollow Output with "G" Pilot Circle Diameter (PCD) Tapped Holes – Dimensions (in)

Base Module	a4	b	B2	b4	b7	b8	e	H	h	i2	lh	m1	s3	s4	t3	t4
KSS1	4.53	2.95	4.17	3.54	2.95	2.76	3.54	4.96	2.36	0.12	4.72	2.36	M8x1.25	M8x1.25	0.51	0.51
KSS2	4.57	3.74	5.28	4.53	3.74	3.54	4.53	5.94	2.56	0.12	5.83	2.56	M10x1.50	M8x1.25	0.63	0.51
KSS3	5.20	3.74	5.75	5.12	4.13	4.13	4.53	6.56	2.95	0.12	6.30	2.95	M10x1.50	M8x1.25	0.63	0.55
KSS4	5.99	4.33	6.81	6.10	5.00	4.72	5.12	7.89	3.54	0.14	7.40	3.54	M12x1.75	M10x1.5	0.75	0.63

Table 2 KSS Series – "AG" Style Motor Adapter Dimensions (in)

Base Module	NEMA C-Face	B	b3	C	E	n	Wt. lbs
KSS102AG_MS1R050	56C	3.54	1.18	10.55	7.03	1.42	29
KSS202AG_MS2R050	56C	4.41	1.38	12.20	7.62	1.81	40
KSS202AG_MS2R140	143/145TC						
KSS203AG_MS2R050	56C	4.53	1.54	13.07	6.64	0.83	53
KSS302AG_MS3R050	56C			13.23	8.29	2.09	55
KSS302AG_MS3R140	143/145TC	5.51	1.38	13.23	8.29	2.09	55
KSS302AG_MS3R180	182/184TC			14.57	9.52	2.07	67
KSS303AG_MS3R050	56C	5.51	1.38	15.22	6.83	0.63	55
KSS303AG_MS3R140	143/145TC						
KSS402AG_MS4R050	56C			14.76	9.66		84
KSS402AG_MS4R140	143/145TC	5.71	1.97	14.76	9.66	2.36	84
KSS402AG_MS4R180	182/184TC			15.79	10.91		89
KSS403AG_MS4R050	56C	5.71	1.97	16.46	8.39	0.98	94
KSS403AG_MS4R140	143/145TC						

Table 3 "A" Hollow Bore Output — Standard Sizes (see page 14 for other available output options)

Base Module	Inches					
	Dh	dh	le	th	uh	Removal Bolt 1
KSS1	1.57	1	3.86	1.11	1/4	1/2 – 13
KSS2	1.97	1-1/4	4.78	1.37	1/4	1/2 – 13
KSS3	1.97	1-3/8	4.92	1.52	5/16	5/8 – 11
KSS4	2.17	1-1/2	6.18	1.67	3/8	3/4 – 10

Dimensional Data

IP68 and IP69K CERTIFIED



"W" Double Bushing Output with "GD" Torque Arm Bracket

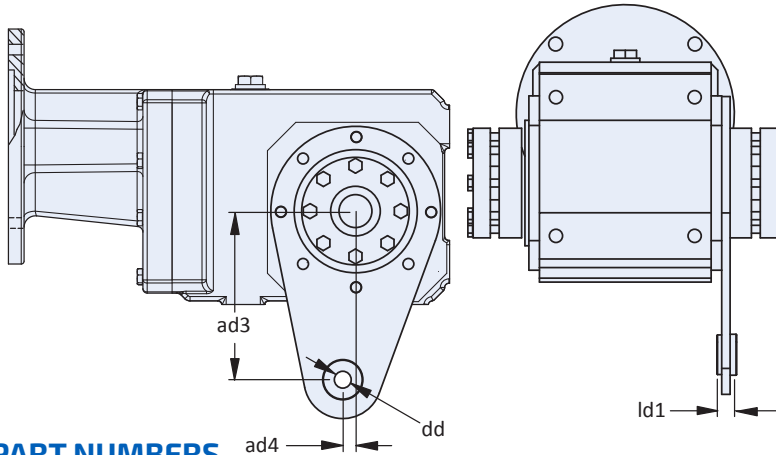

Table 4 "GD" Torque Arm

Base Module	Kit Number	mm			
		ad3	ad4	dd	ld1
KSS1	CS213227	130	10	13	15
KSS2	CS129573	130	10	13	15
KSS3	CS129573	130	10	13	15
KSS4	CS139679	130	10	13	15

Note: a bushing output plastic cover cannot be used on the Torque Arm side of speed reducer. A plastic cover can only be used on the side opposite the torque arm.

KIT PART NUMBERS

- CS137450 (205/206 Flanged Bearing)
- CS137367 (207/208 Flanged Bearing)

Required Shaft Lengths Wobble Free Bushing Length

Unit/Flange Bearing	205/206	207/208
KSS1	10.20	-
KSS2	11.4	11.94
KSS3	10.87	12.42
KSS4	13.19	13.73

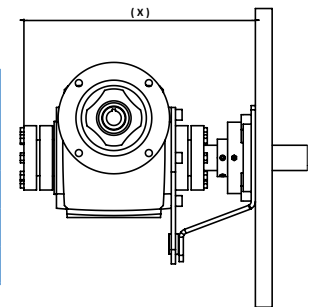

cLEAN Motor Straight or Right Angle Cable Gland Option

Table 5 cLEAN Motor Dimensions (in)

Base Module	AG	AG1	AJ	BE	BF Tap Size	ES	N-W	P	U
CLM502 050	9.08	10.53	5.875	1.19	3/8-16	1.5	1.875	5.5	5/8
CLM503 050	10.38	11.84	5.875	1.19	3/8-16	1.5	1.875	5.5	5/8
CLM503 140	10.58	11.84	5.875	1.19	3/8-16	2.0	2.25	5.5	7/8
CLM505 140	13.14	14.59	5.875	1.19	3/8-16	2.0	2.25	5.5	7/8
CLM505 180	13.38	14.83	7.25	1.41	1/2-13	2.0	2.75	5.5	1-1/8

*AG is overall length of motor housing for straight options.
*AG1 is overall length of motor housing for right angle options.

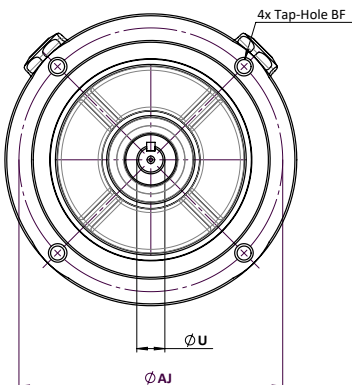
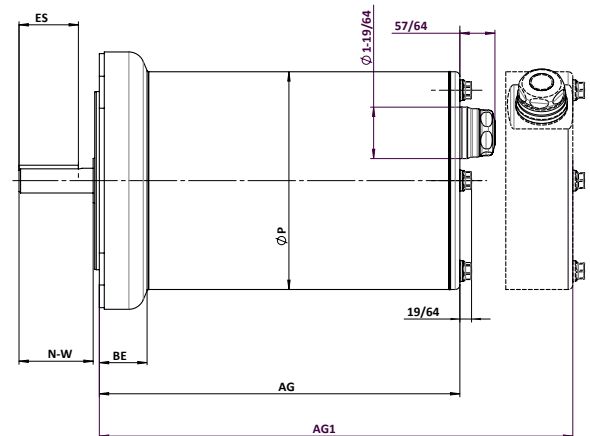

cLEAN Motor Straight Cable Gland

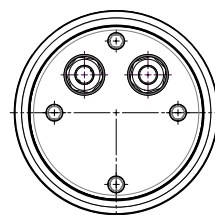

Resolver option has two cables.

cLEAN Motor Right Angle Cable Gland

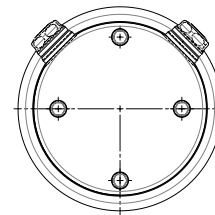

Resolver option has two cables.

Brake is only available in right angle cable gland configuration.

CLEAN System

"A" Hollow Bore Output with "F" Round Flange Housing

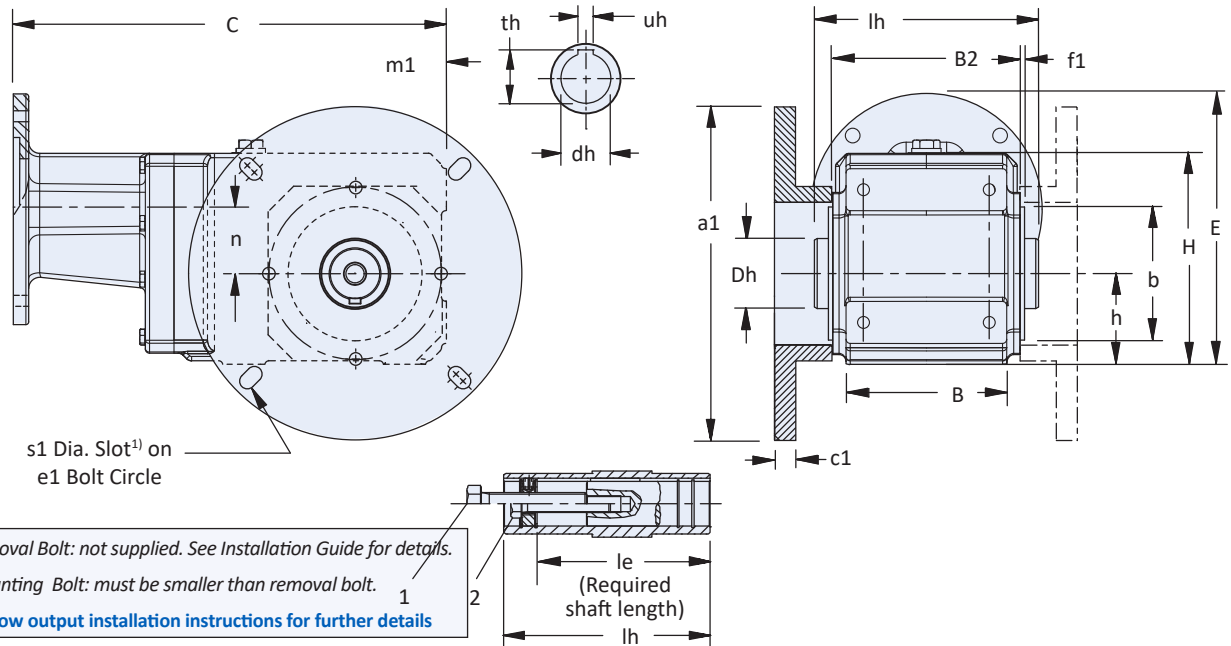

Table 1 KSS Series – "A" Hollow Output with "F" Round Flange Housing – Dimensions (in)

Base Module	a1	b	B2	c1	c2	e1		f1	H	h	lh	m1	s1 ¹⁾
						Min.	Max. ¹⁾						
KSS1	6.75	2.95	4.17	0.55	1.50	5.87	—	0.12	4.96	2.36	4.72	2.36	0.33
KSS2	8.74	3.74	5.28	0.55	1.50	7.48	8.00	0.12	5.94	2.56	5.28	2.56	0.41
KSS3	8.74	3.74	5.75	0.55	1.50	7.48	8.00	0.12	6.56	2.95	6.30	2.95	0.41
KSS4	9.84	4.33	6.81	0.55	1.50	8.46	—	0.14	7.89	3.54	7.40	3.54	0.53

1) KSS1 & KSS4 mounting bolt hole is not a slot.

Table 2 KSS Series – "AF" Style Motor Adapter Dimensions (in)

Base Module	NEMA C-Face	B	C	E	n	Wt. lbs
KSS102AF_MS1R050	56C	3.54	10.09	7.03	1.42	29
KSS202AF_MS2R050	56C	4.41	12.20	7.62	1.81	40
KSS202AF_MS2R140	143/145TC	4.41	12.20	7.62	1.81	40
KSS203AF_MS2R050	56C	4.53	13.07	6.64	1.81	53
KSS302AF_MS3R050	56C	5.51	13.23	8.29	2.09	55
KSS302AF_MS3R140	143/145TC	5.51	13.23	8.29	2.09	55
KSS302AF_MS3R180	182/184TC	5.51	14.57	9.52	2.07	67
KSS303AF_MS3R050	56C	5.51	15.22	6.83	0.63	55
KSS303AF_MS3R140	143/145TC	5.51	15.22	6.83	0.63	55
KSS402AF_MS4R050	56C	5.71	14.76	9.96	2.36	84
KSS402AF_MS4R140	143/145TC	5.71	14.76	9.96	2.36	84
KSS402AF_MS4R180	182/184TC	5.71	15.79	10.91	2.36	89
KSS403AF_MS4R050	56C	5.71	16.46	8.39	0.98	94
KSS403AF_MS4R140	143/145TC	5.71	16.46	8.39	0.98	94

Table 3 "A" Hollow Bore Output — Standard Sizes (see page 14 for other available output options)

Base Module	Inches					
	Dh	dh	le	th	uh	Removal Bolt 1
KSS1	1.57	1	3.86	1.11	1/4	1/2 – 13
KSS2	1.97	1-1/4	4.78	1.37	1/4	1/2 – 13
KSS3	1.97	1-3/8	4.92	1.52	5/16	5/8 – 11
KSS4	2.17	1-1/2	6.18	1.67	3/8	3/4 – 10



cLEAN Motor Straight or Right Angle Cable Gland Option

Table 5 cLEAN Motor Dimensions (in)

Base Module	AG	AG1	AJ	BE	BF Tap Size	ES	N-W	P	U
CLM502 050	9.08	10.53	5.875	1.19	3/8-16	1.5	1.875	5.5	5/8
CLM503 050	10.38	11.84	5.875	1.19	3/8-16	1.5	1.875	5.5	5/8
CLM503 140	10.58	11.84	5.875	1.19	3/8-16	2.0	2.25	5.5	7/8
CLM505 140	13.14	14.59	5.875	1.19	3/8-16	2.0	2.25	5.5	7/8
CLM505 180	13.38	14.83	7.25	1.41	1/2-13	2.0	2.75	5.5	1-1/8

*AG is overall length of motor housing for straight options.

*AG1 is overall length of motor housing for right angle options.

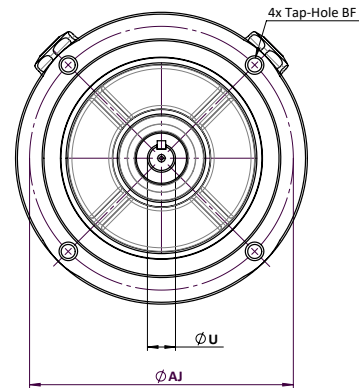
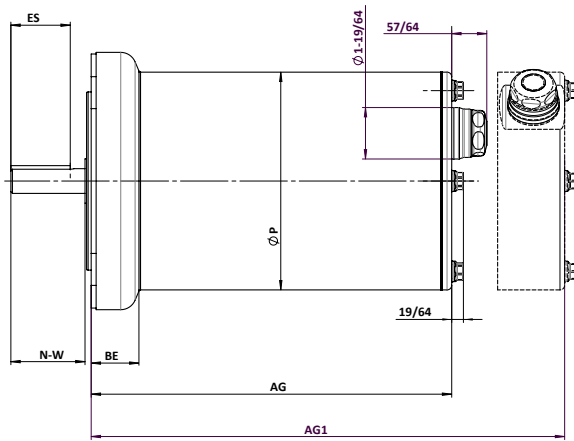

cLEAN Motor Straight Cable Gland

Resolver option has two cables.

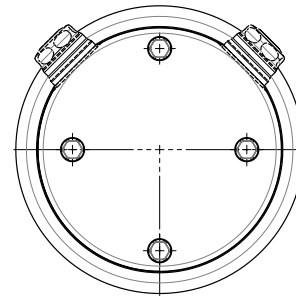

cLEAN Motor Right Angle Cable Gland

Resolver option has two cables.

Brake is only available in right angle cable gland configuration.

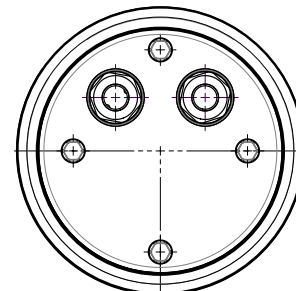

Dimensional Data

cLEAN System: GEARBOX & MOTOR

“V” Solid Shaft Output with “F” Round Flange Housing

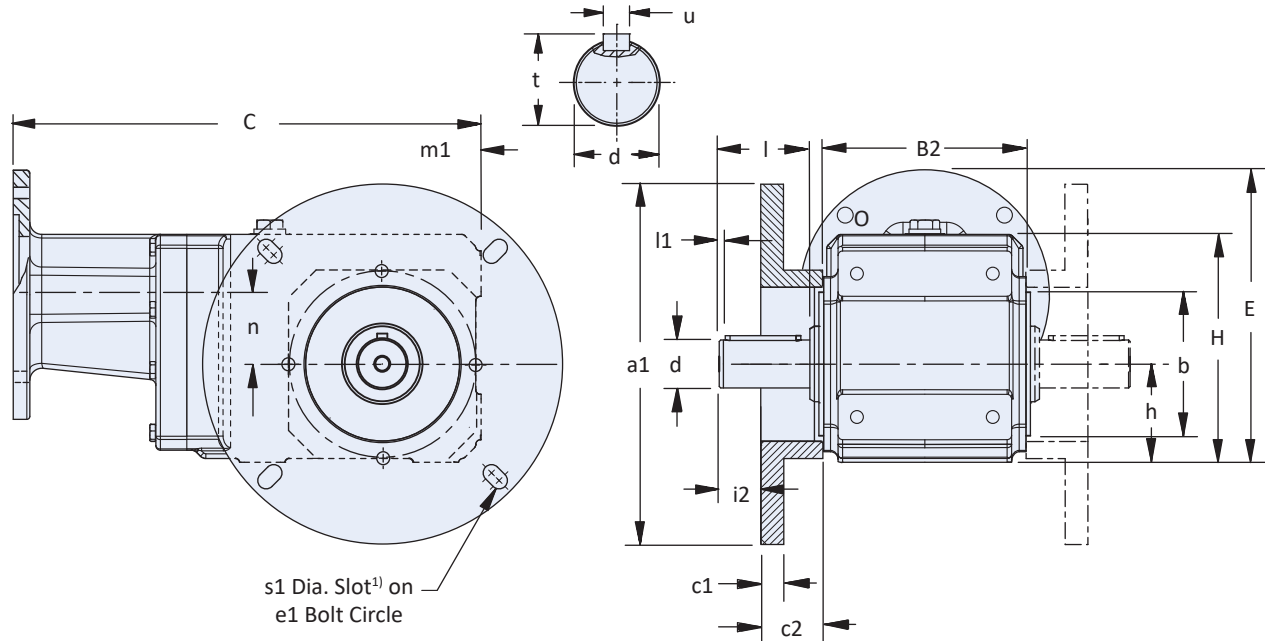

Table 1 KSS Series – “V” Solid Shaft Output with “F” Round Flange Housing Dimensions (in)

Base Module	a1	b	B2	c1	c2	e1		H	h	i2	l	l1	m1	s1 ¹⁾
						Min.	Max. ¹⁾							
KSS1	6.75	2.95	4.17	0.55	1.50	5.87	—	4.96	2.36	0.94	1.97	0.16	2.36	0.33
KSS2	8.74	3.74	5.28	0.55	1.50	7.48	8.00	5.94	2.56	1.21	2.36	0.16	2.56	0.41
KSS3	8.74	3.74	5.75	0.55	1.50	7.48	8.00	6.56	2.95	1.21	2.36	0.16	2.95	0.41
KSS4	9.84	4.33	6.81	0.55	1.50	8.46	—	7.89	3.54	1.63	2.76	0.16	3.54	0.53

1) KSS1 & KSS4 mounting bolt hole is not a slot.

Table 2 KSS Series – “VF” Style Motor Adapter Dimensions (in)

Base Module	NEMA C-Face	C	E	n	Wt. lbs
KSS102VF_MS1R050	56C	10.55	7.03	1.42	29
KSS202VF_MS2R050	56C	12.20	7.62	1.81	40
KSS202VF_MS2R140	143/145TC				
KSS203VF_MS2R050	56C	13.07	6.64	0.83	53
KSS302VF_MS3R050	56C	13.23	8.29	2.09	55
KSS302VF_MS3R140	143/145TC	13.23	8.29	2.09	55
KSS302VF_MS3R180	182/184TC	14.57	9.52	2.07	67
KSS303VF_MS3R050	56C	15.22	6.83	0.63	55
KSS303VF_MS3R140	143/145TC				
KSS402VF_MS4R050	56C	14.76	9.96	2.36	84
KSS402VF_MS4R140	143/145TC	14.76	9.96		84
KSS402VF_MS4R180	182/184TC	15.79	10.91		89
KSS403VF_MS4R050	56C	16.46	8.39	0.98	94
KSS403VF_MS4R140	143/145TC				

Table 3 “V” Solid Shaft Output — Standard Sizes

Base Module	Inches		
	d	t	u— Key
KSS1	1	1.11	1/4 x 1/4 x 1-9/16
KSS2	1-1/4	1.36	1/4 x 1/4 x 1-15/16
KSS3	1-1/4	1.36	1/4 x 1/4 x 1-15/16
KSS4	1-3/8	1.51	5/16 x 5/16 x 2-5/16



cLEAN Motor Straight or Right Angle Cable Gland Option

Table 5 cLEAN Motor Dimensions (in)

Base Module	AG	AG1	AJ	BE	BF Tap Size	ES	N-W	P	U
CLM502 050	9.08	10.53	5.875	1.19	3/8-16	1.5	1.875	5.5	5/8
CLM503 050	10.38	11.84	5.875	1.19	3/8-16	1.5	1.875	5.5	5/8
CLM503 140	10.58	11.84	5.875	1.19	3/8-16	2.0	2.25	5.5	7/8
CLM505 140	13.14	14.59	5.875	1.19	3/8-16	2.0	2.25	5.5	7/8
CLM505 180	13.38	14.83	7.25	1.41	1/2-13	2.0	2.75	5.5	1-1/8

*AG is overall length of motor housing for straight options.

*AG1 is overall length of motor housing for right angle options.

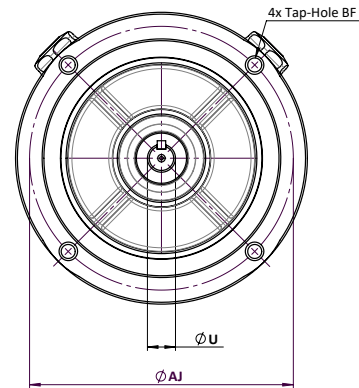
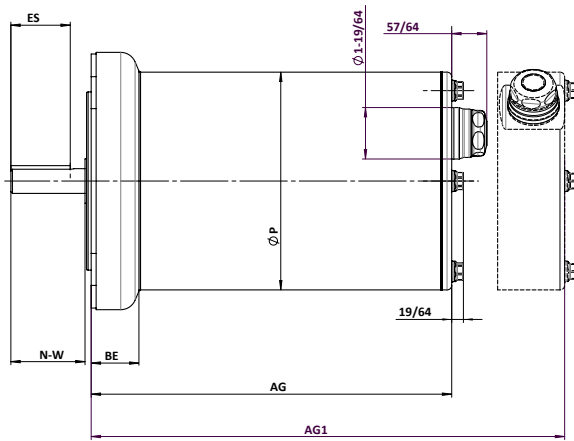

cLEAN Motor Straight Cable Gland

Resolver option has two cables.

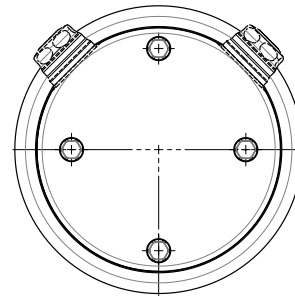

cLEAN Motor Right Angle Cable Gland

Resolver option has two cables.

Brake is only available in right angle cable gland configuration.

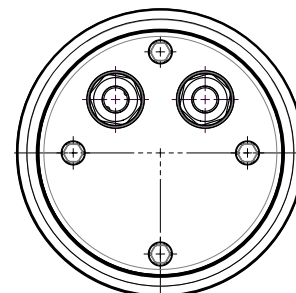

"V" Solid Shaft Output with "G" Pilot Circle Diameter (PCD) Tapped Holes

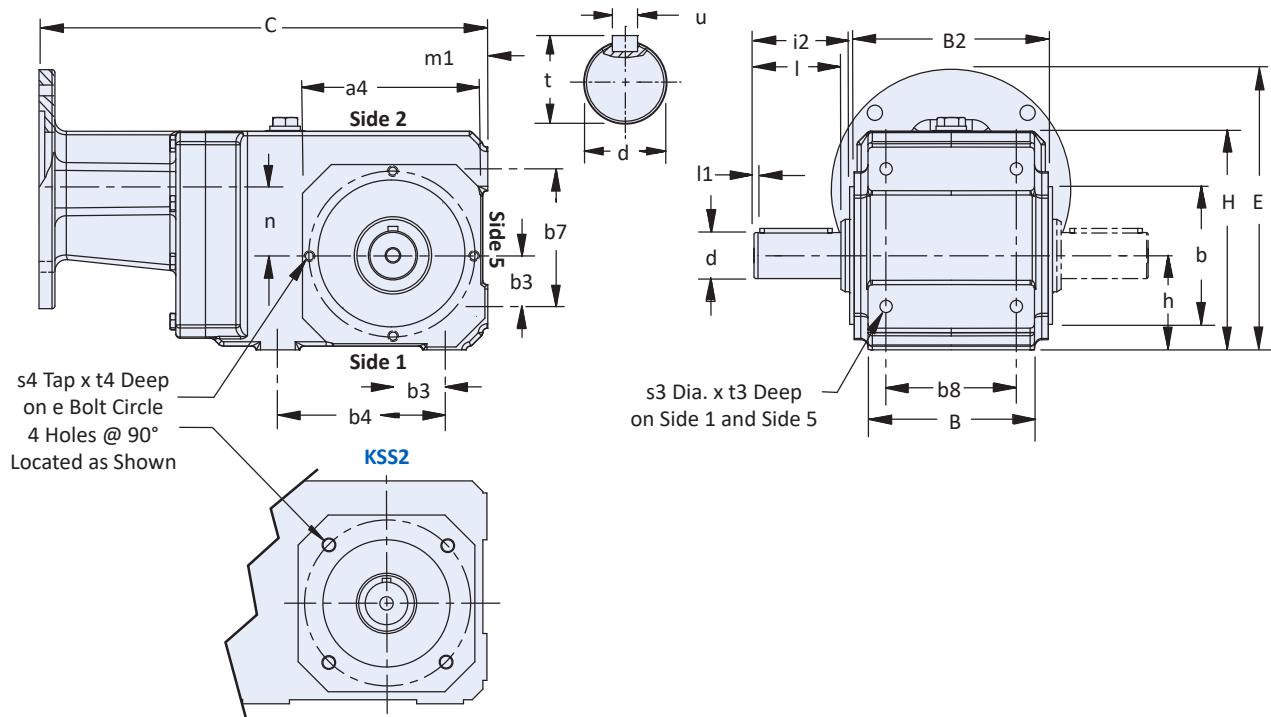

Table 1 KSS Series – "V" Solid Shaft Output with "G" Pilot Circle Diameter (PCD) Tapped Holes – Dimensions (in)

Base Module	a4	b	B2	b3	b4	b7	b8	e	H	h	i2	l	l1	m1	s3	s4	t3	t4
KSS1	4.53	2.95	4.17	1.18	3.54	2.95	2.76	3.54	4.96	2.36	2.32	1.97	0.16	2.36	M8x1.25	M8x1.25	0.51	0.51
KSS2	4.57	3.74	5.28	1.38	4.53	3.74	3.54	4.53	5.94	2.56	2.60	2.36	0.16	2.56	M10x1.50	M8x1.25	0.63	0.51
KSS3	5.20	3.74	5.75	1.38	5.12	4.13	4.13	4.53	6.56	2.95	2.60	2.36	0.16	2.95	M10x1.50	M8x1.25	0.63	0.55
KSS4	5.99	4.33	6.81	1.97	6.10	5.00	4.72	5.12	7.89	3.54	3.39	2.76	0.16	3.54	M12x1.75	M10x1.5	0.75	0.63

Table 2 KSS Series – "VG" Style Motor Adapter Dimensions (in)

Base Module	NEMA C-Face	a6	B	b6	C	c6	E	e6	m	n	s6	Wt. lbs
KSS102VG_MS1R050	56C	6.50	3.54	4.500	10.55	3.81	7.03	5.87	4.38	1.42	0.41	29
KSS202VG_MS2R050	56C	6.50	4.41	4.500	12.20	4.53	7.62	5.87	5.11	1.81	0.41	40
KSS202VG_MS2R140	143/145TC	6.50	4.53	4.500	13.07	3.31	6.64	5.87	7.20	0.83	0.41	53
KSS203VG_MS2R050	56C	6.50	4.53	4.500	13.23	4.37	8.29	5.87	5.91	2.09	0.41	55
KSS302VG_MS3R050	56C	6.50	5.51	4.500	13.23	4.37	8.29	5.87	5.91	2.09	0.41	55
KSS302VG_MS3R140	143/145TC	6.50	5.51	4.500	13.23	4.37	8.29	5.87	5.91	2.09	0.41	55
KSS302VG_MS3R180	182/184TC	9.00	5.51	4.500	14.57	6.59	9.52	7.25	5.03	2.07	0.55	67
KSS303VG_MS3R050	56C	6.50	5.51	4.500	15.22	4.00	6.83	5.87	8.27	0.63	0.41	55
KSS303VG_MS3R140	143/145TC	6.50	5.51	4.500	15.22	4.00	6.83	5.87	8.27	0.63	0.41	55
KSS402VG_MS4R050	56C	6.50	5.71	4.500	14.76	4.53	9.96	5.87			0.41	84
KSS402VG_MS4R140	143/145TC	6.50	5.71	4.500	14.76	4.53	9.96	5.87	6.69	2.36	0.41	84
KSS402VG_MS4R180	182/184TC	9.00	5.71	4.500	15.79	5.55	10.91	7.25			0.55	89
KSS403VG_MS4R050	56C	6.50	5.71	4.500	16.46	3.86	8.39	5.87	9.06	0.98	0.41	94
KSS403VG_MS4R140	143/145TC	6.50	5.71	4.500	16.46	3.86	8.39	5.87	9.06	0.98	0.41	94

Table 3 "V" Solid Shaft Output — Standard Sizes

Base Module	Inches		
	d	t	u— Key
KSS1	1	1.11	1/4 x 1/4 x 1-9/16
KSS2	1-1/4	1.36	1/4 x 1/4 x 1-15/16
KSS3	1-1/4	1.36	1/4 x 1/4 x 1-15/16
KSS4	1-3/8	1.51	5/16 x 5/16 x 2-5/16

IP68 and IP69K CERTIFIED

"W" Double Bushing Output with "GD" Torque Arm Bracket

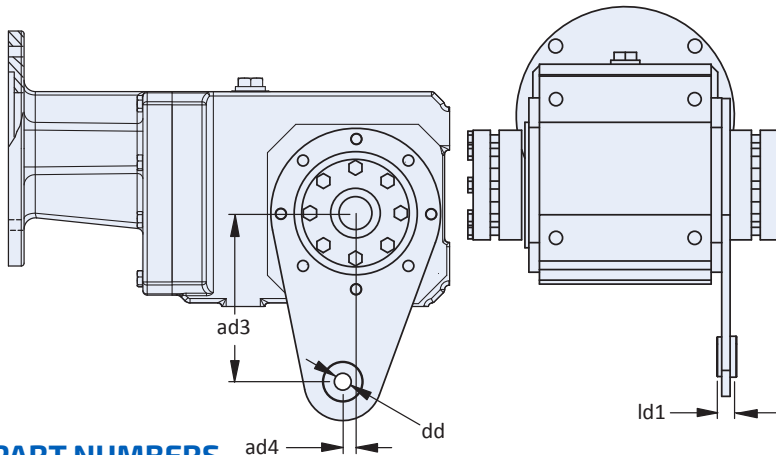

Table 4 "GD" Torque Arm

Base Module	Kit Number	mm			
		ad3	ad4	dd	ld1
KSS1	CS213227	130	10	13	15
KSS2	CS129573	130	10	13	15
KSS3	CS129573	130	10	13	15
KSS4	CS139679	130	10	13	15

Note: a bushing output plastic cover cannot be used on the Torque Arm side of speed reducer. A plastic cover can only be used on the side opposite the torque arm.

KIT PART NUMBERS

CS137450 (205/206 Flanged Bearing)
CS137367 (207/208 Flanged Bearing)

Required Shaft Lengths Wobble Free Bushing Length

Unit/Flange Bearing	205/206	207/208
KSS1	10.20	-
KSS2	11.4	11.94
KSS3	10.87	12.42
KSS4	13.19	13.73

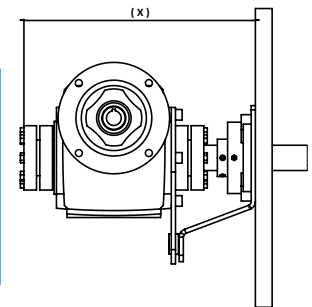

cLEAN Motor Straight or Right Angle Cable Gland Option

Table 5 cLEAN Motor Dimensions (in)

Base Module	AG	AG1	AJ	BE	BF Tap Size	ES	N-W	P	U
CLM502 050	9.08	10.53	5.875	1.19	3/8-16	1.5	1.875	5.5	5/8
CLM503 050	10.38	11.84	5.875	1.19	3/8-16	1.5	1.875	5.5	5/8
CLM503 140	10.58	11.84	5.875	1.19	3/8-16	2.0	2.25	5.5	7/8
CLM505 140	13.14	14.59	5.875	1.19	3/8-16	2.0	2.25	5.5	7/8
CLM505 180	13.38	14.83	7.25	1.41	1/2-13	2.0	2.75	5.5	1-1/8

*AG is overall length of motor housing for straight options.
*AG1 is overall length of motor housing for right angle options.

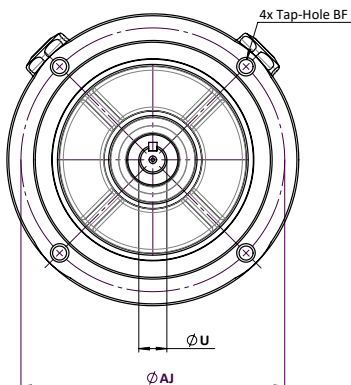
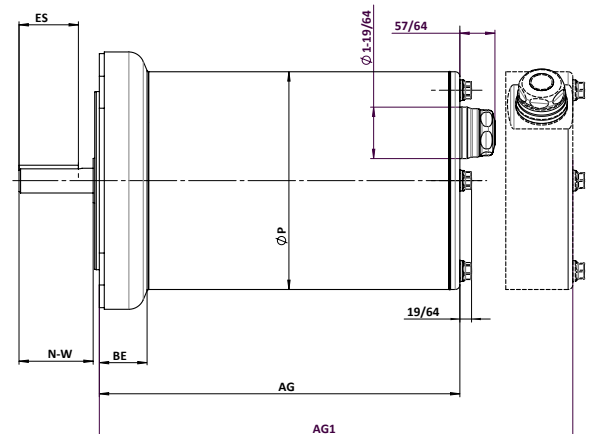

cLEAN Motor Straight Cable Gland

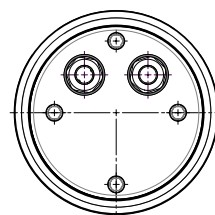

Resolver option has two cables.

cLEAN Motor Right Angle Cable Gland

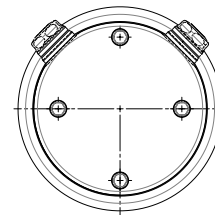

Resolver option has two cables.

Brake is only available in right angle cable gland configuration.

cLEAN System



“V” Solid Shaft Output with “NG” Foot Mount Housing

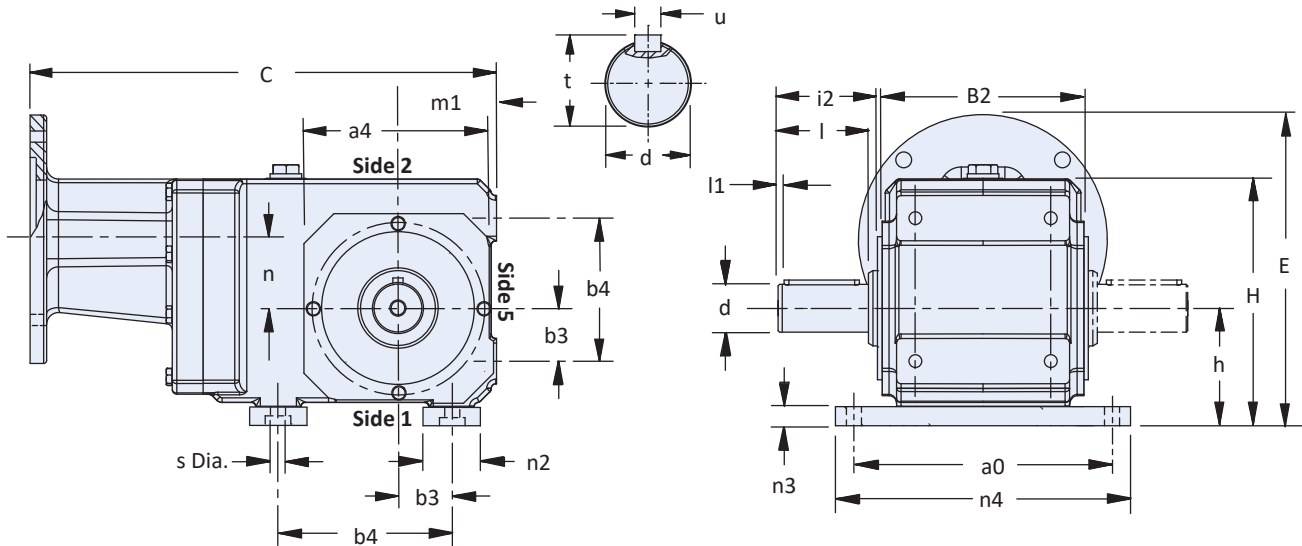

Table 1 KSS Series – “V” Solid Shaft Output with “NG” Foot Mount – Dimensions (in)

Base Module	a0	a4	B2	b3	b4	b7	e	H	h	i2	l	l1	m1	n2	n3	n4	s
KSS1	4.53	4.53	4.17	1.18	3.54	2.95	3.54	5.46	2.36	2.32	1.97	0.16	2.36	1.50	0.50	5.51	0.35
KSS2	6.73	4.57	5.28	1.38	4.53	3.74	4.53	6.44	3.07	2.60	2.36	0.16	2.56	1.50	0.50	7.72	0.39
KSS3	6.73	5.20	5.75	1.38	5.12	4.13	4.53	7.06	3.44	2.60	2.36	0.16	2.95	1.50	0.50	7.72	0.39
KSS4	7.87	5.99	6.81	1.97	6.10	5.00	5.12	8.64	3.54	3.39	2.76	0.16	3.54	1.50	0.75	9.06	0.55

Table 2 KSS Series – “VNG” Style Motor Adapter Dimensions (in)

Base Module	NEMA C-Face	a4	C	E	n	Wt. lbs
KSS102VNG_MS1R050	56C	4.53	10.55	7.53	1.42	29
KSS202VNG_MS2R050	56C	4.57	12.20	8.12	1.81	40
KSS202VNG_MS2R140	143/145TC					
KSS203VNG_MS2R050	56C	4.57	13.07	7.14	0.83	53
KSS302VNG_MS3R050	56C		13.23	8.79	2.09	55
KSS302VNG_MS3R140	143/145TC	5.20	13.23	8.79	2.09	55
KSS302VNG_MS3R180	182/184TC		14.57	10.02	2.07	67
KSS303VNG_MS3R050	56C	5.20	15.22	7.33	0.63	55
KSS303VNG_MS3R140	143/145TC					
KSS402VNG_MS4R050	56C		14.76	10.41		84
KSS402VNG_MS4R140	143/145TC	5.99	14.76	10.41	2.36	84
KSS402VNG_MS4R180	182/184TC		15.79	11.66		89
KSS403VNG_MS4R050	56C	5.99	16.46	9.14	0.98	94
KSS403VNG_MS4R140	143/145TC					

Table 3 “V” Solid Shaft Output — Standard Sizes

Base Module	Inches		
	d	t	u- Key
KSS1	1	1.11	1/4 x 1/4 x 1-9/16
KSS2	1-1/4	1.36	1/4 x 1/4 x 1-15/16
KSS3	1-1/4	1.36	1/4 x 1/4 x 1-15/16
KSS4	1-3/8	1.51	5/16 x 5/16 x 2-5/16

IP68 and IP69K CERTIFIED

"W" Double Bushing Output with "GD" Torque Arm Bracket

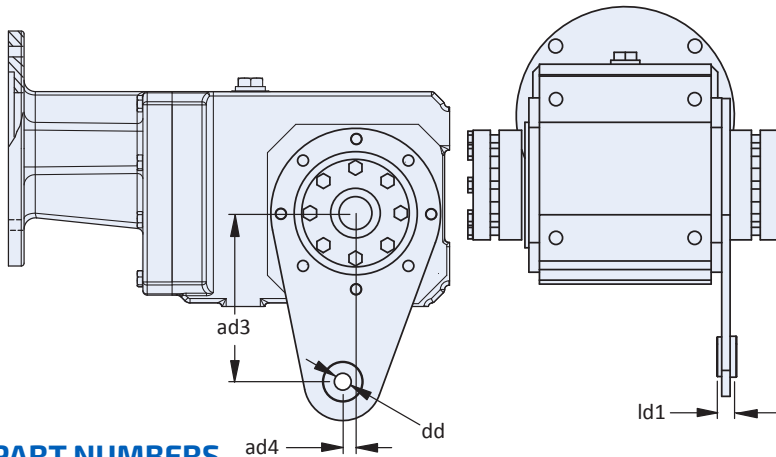

Table 4 "GD" Torque Arm

Base Module	Kit Number	mm			
		ad3	ad4	dd	ld1
KSS1	CS213227	130	10	13	15
KSS2	CS129573	130	10	13	15
KSS3	CS129573	130	10	13	15
KSS4	CS139679	130	10	13	15

Note: a bushing output plastic cover cannot be used on the Torque Arm side of speed reducer. A plastic cover can only be used on the side opposite the torque arm.

KIT PART NUMBERS

CS137450 (205/206 Flanged Bearing)
CS137367 (207/208 Flanged Bearing)

Required Shaft Lengths Wobble Free Bushing Length

Unit/Flange Bearing	205/206	207/208
KSS1	10.20	-
KSS2	11.4	11.94
KSS3	10.87	12.42
KSS4	13.19	13.73

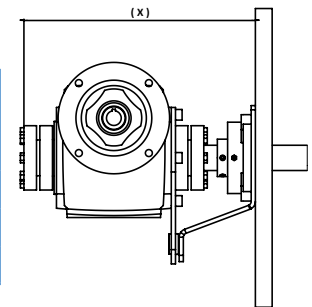

cLEAN Motor Straight or Right Angle Cable Gland Option

Table 5 cLEAN Motor Dimensions (in)

Base Module	AG	AG1	AJ	BE	BF Tap Size	ES	N-W	P	U
CLM502 050	9.08	10.53	5.875	1.19	3/8-16	1.5	1.875	5.5	5/8
CLM503 050	10.38	11.84	5.875	1.19	3/8-16	1.5	1.875	5.5	5/8
CLM503 140	10.58	11.84	5.875	1.19	3/8-16	2.0	2.25	5.5	7/8
CLM505 140	13.14	14.59	5.875	1.19	3/8-16	2.0	2.25	5.5	7/8
CLM505 180	13.38	14.83	7.25	1.41	1/2-13	2.0	2.75	5.5	1-1/8

*AG is overall length of motor housing for straight options.
*AG1 is overall length of motor housing for right angle options.

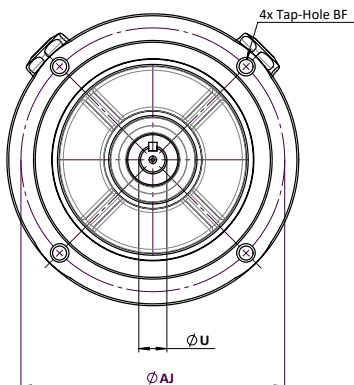
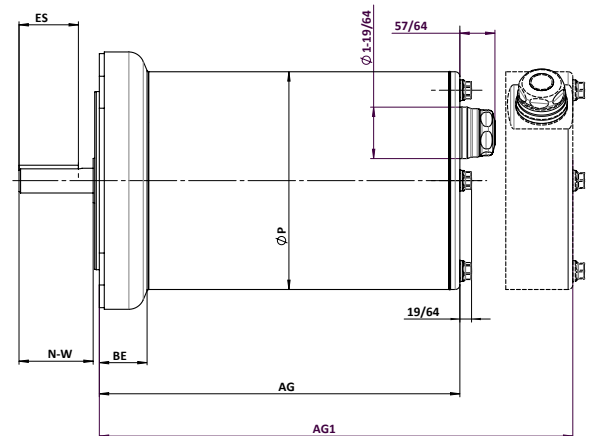

cLEAN Motor Straight Cable Gland

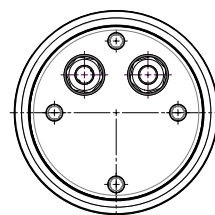

Resolver option has two cables.

cLEAN Motor Right Angle Cable Gland

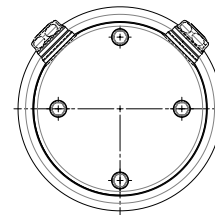

Resolver option has two cables.

Brake is only available in right angle cable gland configuration.

cLEAN System

Torque Speed Curves for CLM502 (1HP)

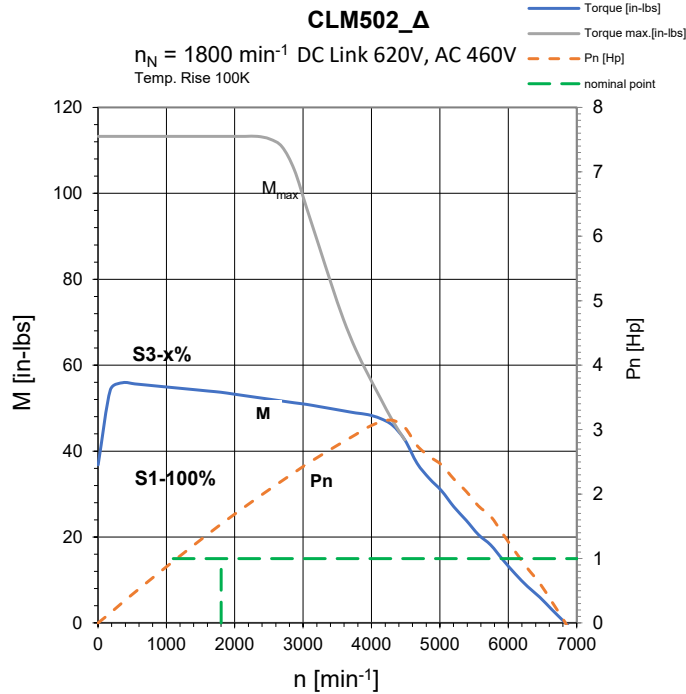
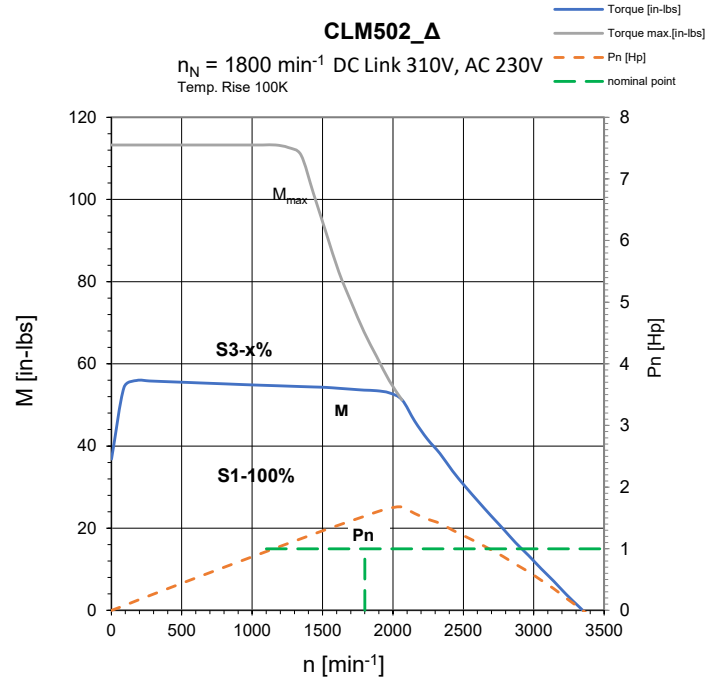
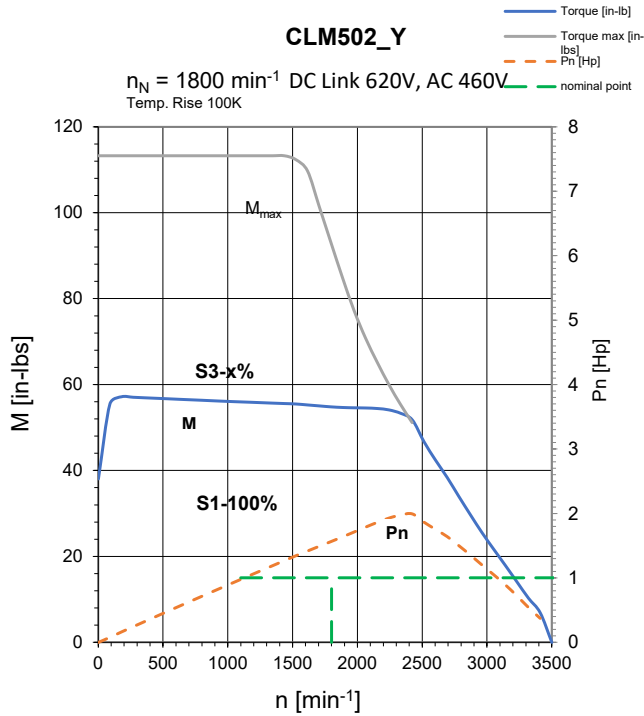



Torque Speed Curves for CLM503 (2HP)

CLEAN System

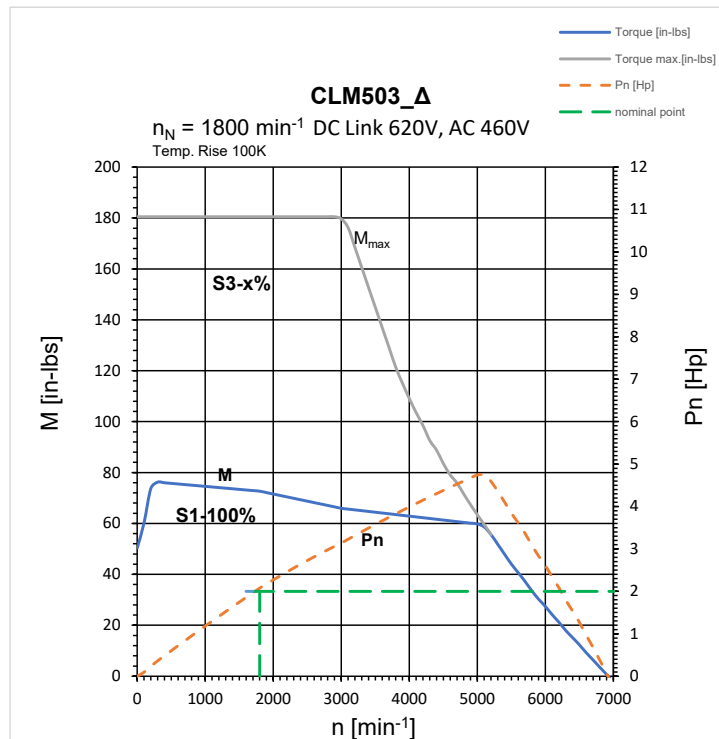
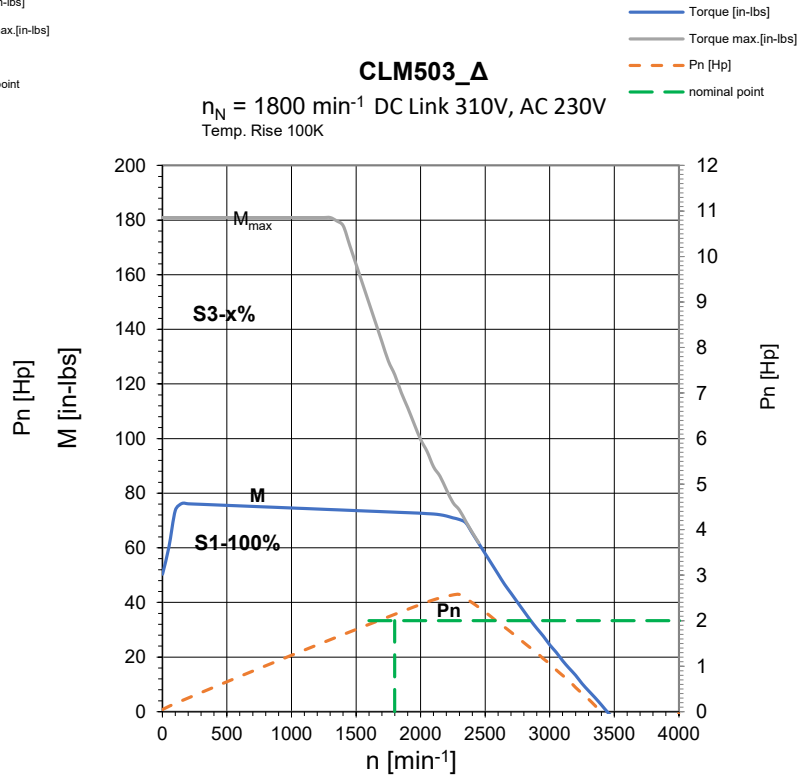
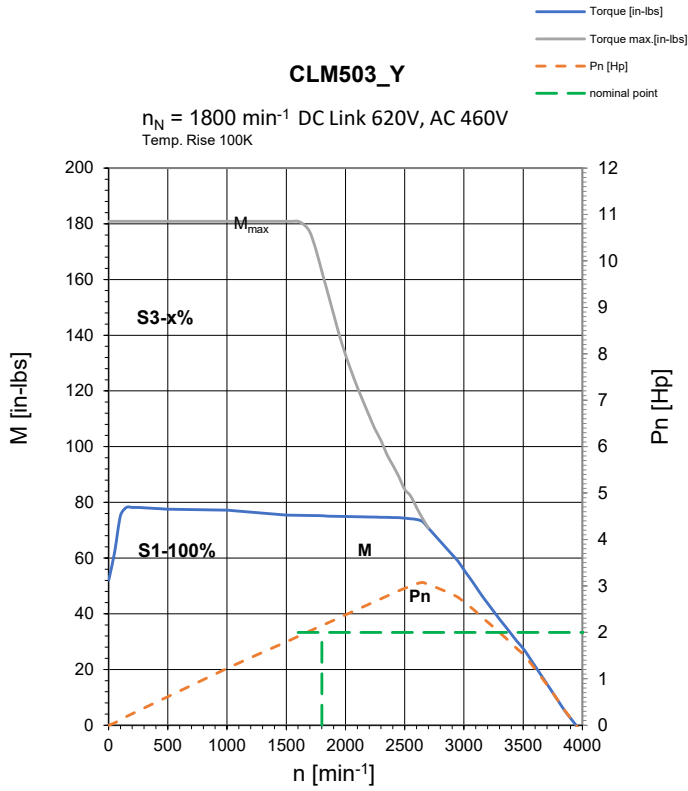

Torque Speed Curves for CLM505 (3HP)

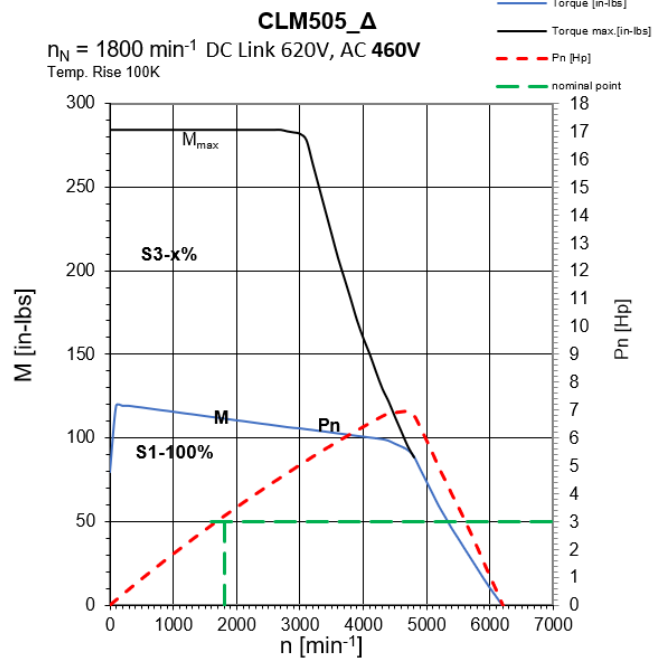
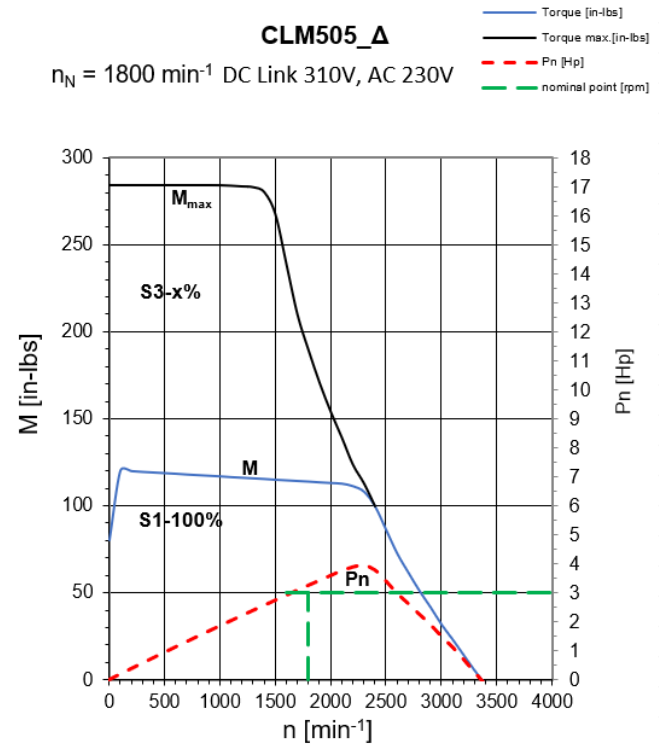
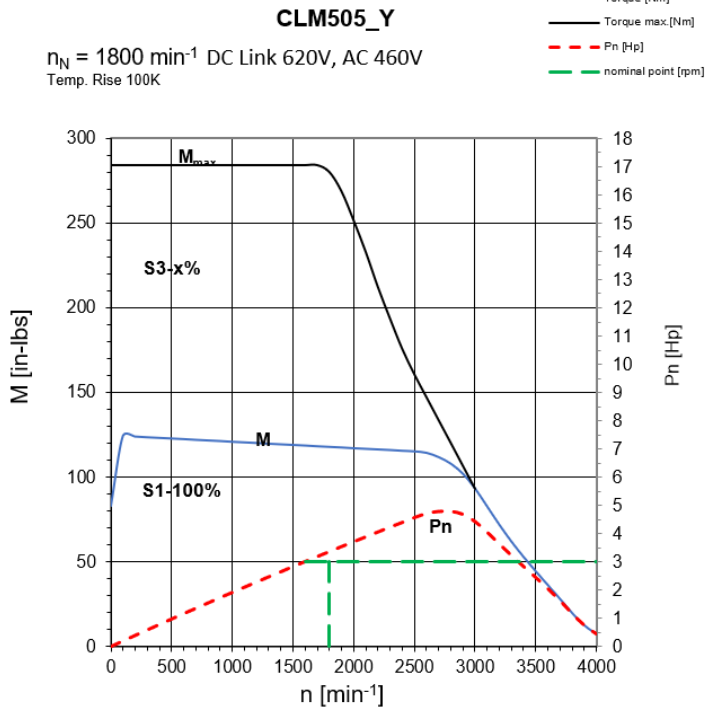

IP68 and IP69K CERTIFIED

CLEAN System



cLEAN System: MOTOR

Features

- All stainless steel hardware
- High frequency injection technology
- Speeds from 0 - 3000 RPM
- IE5 Efficiency
- Double seals on all ingress points

The cLEAN Motor is available as a standalone motor if you are already using a KSS gearbox. It is IP68 and IP69K Certified, capable of handling the harshest washdowns. It is totally enclosed preventing water ingress and eliminating premature failure.

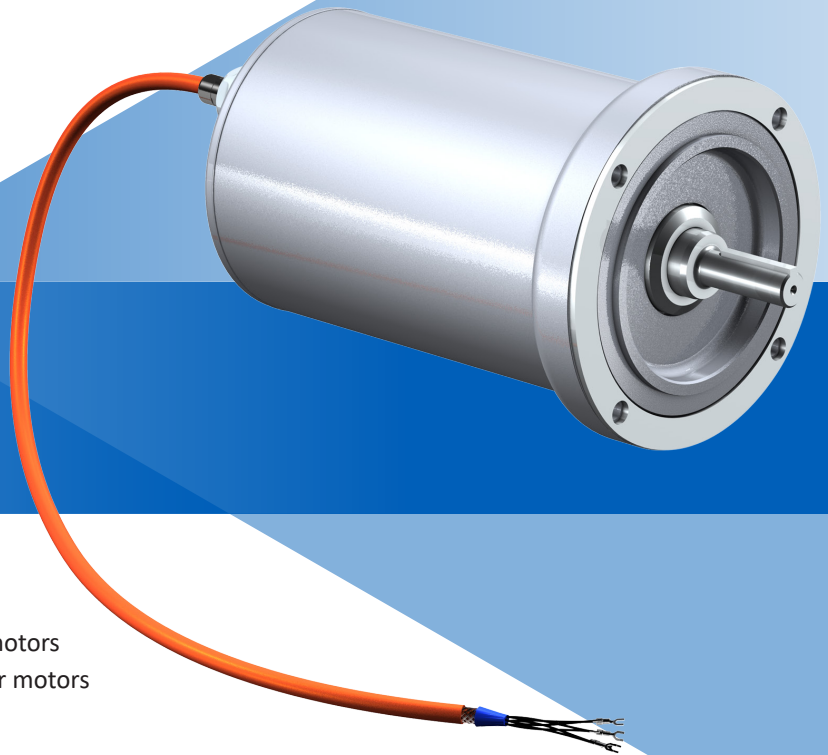

Benefits

- 3 year warranty
- Compact - 1/3 smaller than competitor motors
- Runs cooler - 86°F cooler than competitor motors
- No maintenance - totally enclosed
- No harborage point for bacteria
- Energy savings - up to 92% efficiency
- IP68 and IP69K Certified to prevent water and dust ingress
- Designed to EHEDG Standards
- Assembled in USA
- 1 day lead time
- UL Certified
- Available with Resolver encoder option for motor feedback
- Available with brake

Overview

IP68 and IP69K CERTIFIED



Ordering Options At-a-Glance

Use the appropriate order codes below to build a part number for the complete assembly.

Part Number Example: **1** **2** **3** **4** **5** **6** **7** **8** **9** **10** **11** **12**
CLM **5** **0** **2** **U** **S** **HF** **RO** **P** **201** **S** **/140**

Design Option	Part Number Code	Description
1 Series	CLM	cLEAN motor - all stainless steel
2 Size	5	1 size
3 Generation	0	Version of motor
4 Length	2 3 5	Number of motor magnet stacks (2 is 1HP, 3 is 2HP, 5 is 3HP)
5 Cooling	U	Convection cooling
6 Design	S	Standard
7 Drive Controller	HF HG	HF - Delta MH300 HG - 3rd Party Drive
8 Encoder	00 RO	00 - No feedback RO - Resolver
9 Brake	O P	O - Without P - Permanent Magnet Brake
10 Voltage Constant	201	201 V/1000 rpm
11 Connection Method	S R	S - Straight R - Right Angle
12 NEMA Frame Size	050 140 180	56C 143/145TC 182/184TC

CLEAN System

cLEAN System: MOTOR

Part Number Codes	Nom. Power (P _N)	AC Voltage (U _{AC})	Rated Speed (n _N)	Nom. Torque (M _N)	Nom. Current (I _N)	Torque Constant (K _{MN})	Nom. Power (P _N)	Motor Eff. (η _{mot})	Max Torque (M _{max})	Max Current (I _{max})	Weight (m)	Voltage Constant (K _{EM})	Temperature Rise @ Rated Load in Winding
	HP	V	RPM	In. Lbs.	A	In. Lbs/A	kW	%	In. Lbs.	A	Lbs.	V/1000 RPM	F
CLM502U	1	460Y	1800	35.30	1.60	22.07	0.75	90.77	113.29	4.86	35.00	94/84	83.0
		230Δ	1800	35.30	2.73	12.94	0.75	88.18	113.29	8.42	35.00	54/49	102.5
		460Δ	3000	21.15	1.74	12.16	0.75	90.62	113.29	8.42	35.00	54/49	76.0
CLM503U	2	460Y	1800	70.54	3.25	21.70	1.50	91.00	180.56	7.76	44.75	92/82	153.0
		230Δ	1800	70.63	5.67	12.66	1.50	88.90	180.56	13.44	44.75	53/48	160.0
		460Δ	3000	42.31	3.57	11.85	1.50	90.94	180.56	13.44	44.75	53/48	112.0
CLM505U	3	460Y	1800	104.16	4.43	23.52	2.2	92.25	284.11	17.8	58.17	97/87	124.7
		230Δ	1800	104.25	7.65	13.63	2.2	91.37	284.11	30.83	58.17	56/46	160.7
		460Δ	3000	63.63	5.06	12.58	2.2	92.1	284.11	30.83	58.17	56/46	124.7



cLEAN Motor Straight or Right Angle Cable Gland Option

Table 5 cLEAN Motor Dimensions (in)

Base Module	AG	AG1	AJ	BE	BF Tap Size	ES	N-W	P	U
CLM502 050	9.08	10.53	5.875	1.19	3/8-16	1.5	1.875	5.5	5/8
CLM503 050	10.38	11.84	5.875	1.19	3/8-16	1.5	1.875	5.5	5/8
CLM503 140	10.58	11.84	5.875	1.19	3/8-16	2.0	2.25	5.5	7/8
CLM505 140	13.14	14.59	5.875	1.19	3/8-16	2.0	2.25	5.5	7/8
CLM505 180	13.38	14.83	7.25	1.41	1/2-13	2.0	2.75	5.5	1-1/8

*AG is overall length of motor housing for straight options.

*AG1 is overall length of motor housing for right angle options.

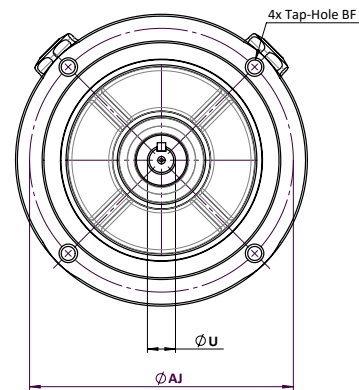
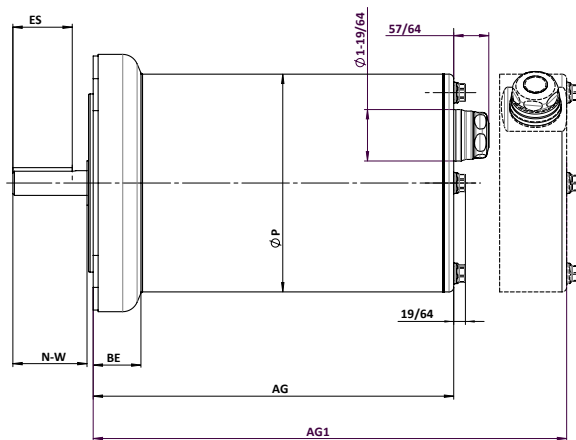

cLEAN Motor Straight Cable Gland

Resolver option has two cables.

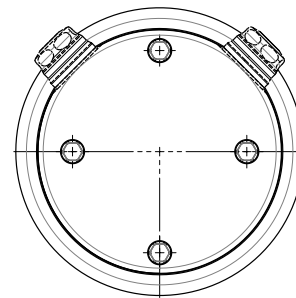

cLEAN Motor Right Angle Cable Gland

Resolver option has two cables.

Brake is only available in right angle cable gland configuration.

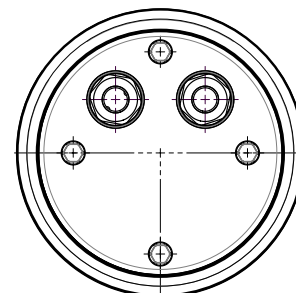

Torque Speed Curves for CLM502 (1HP)

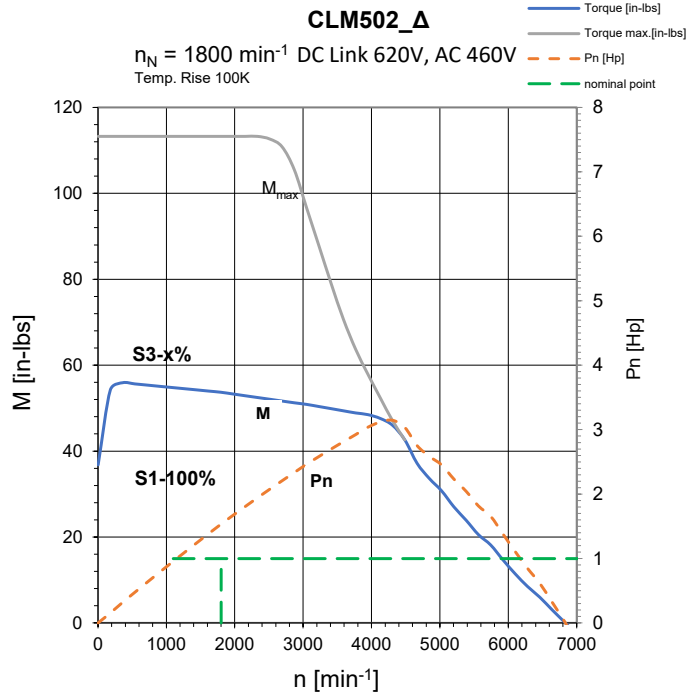
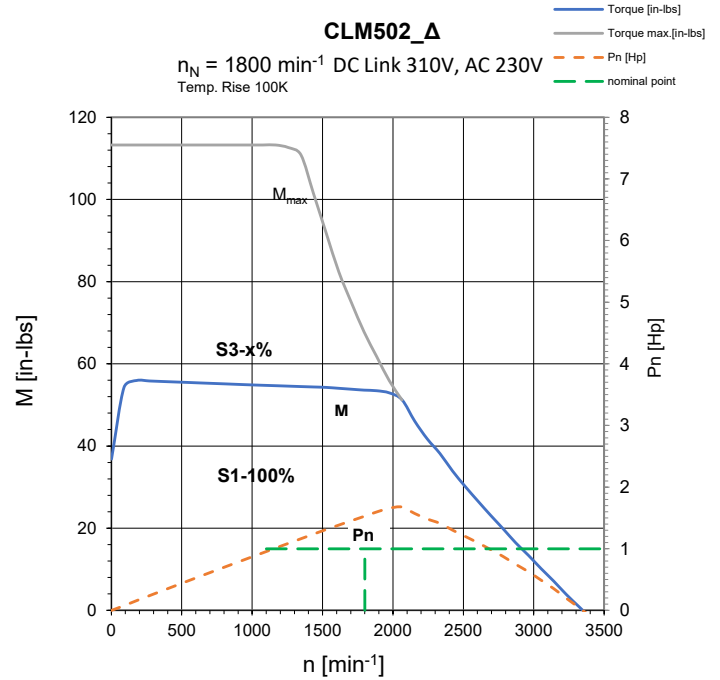
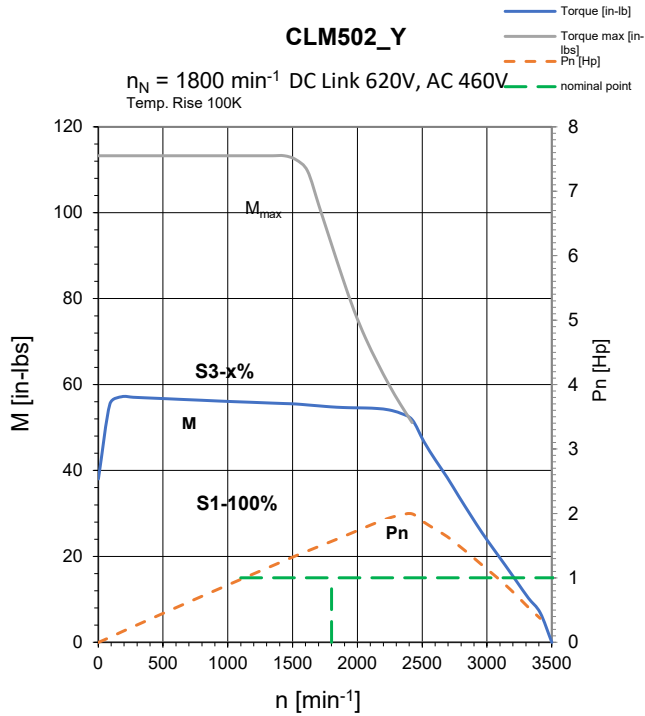



Torque Speed Curves for CLM503 (2HP)

CLEAN System

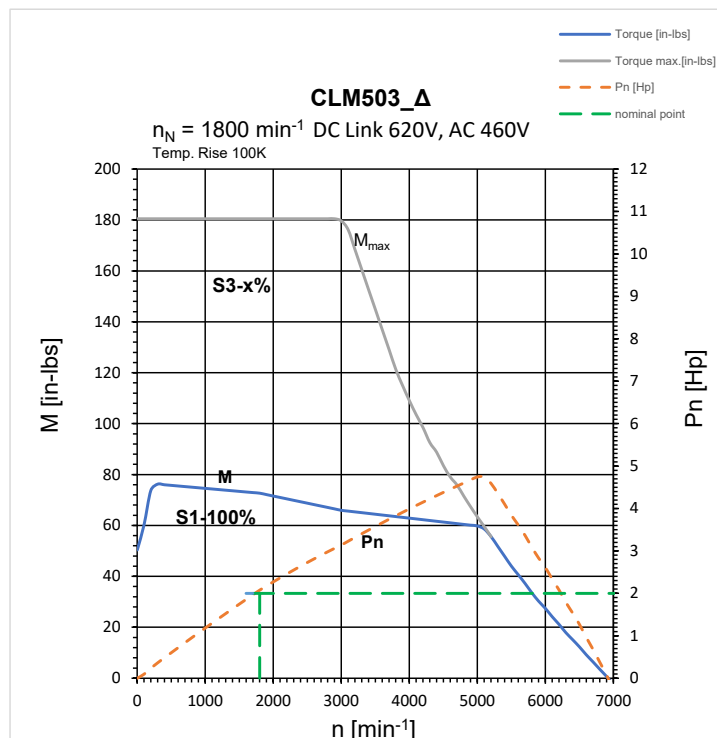
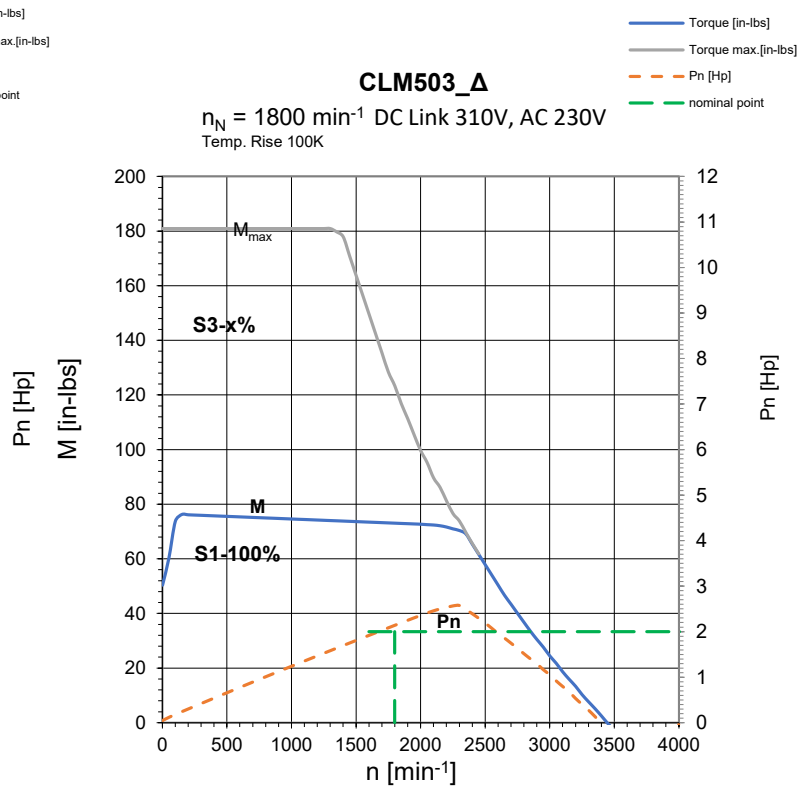
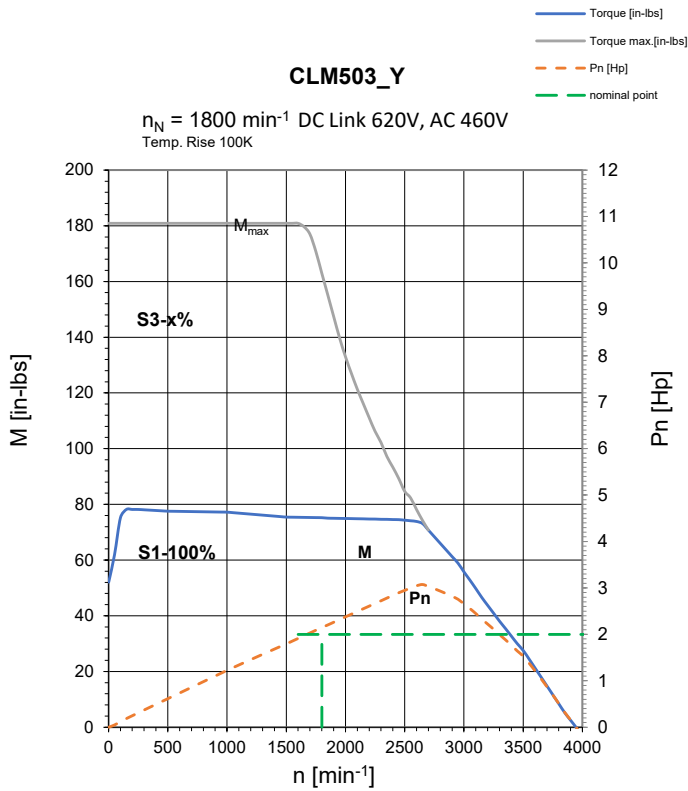

Torque Speed Curves for CLM505 (3HP)

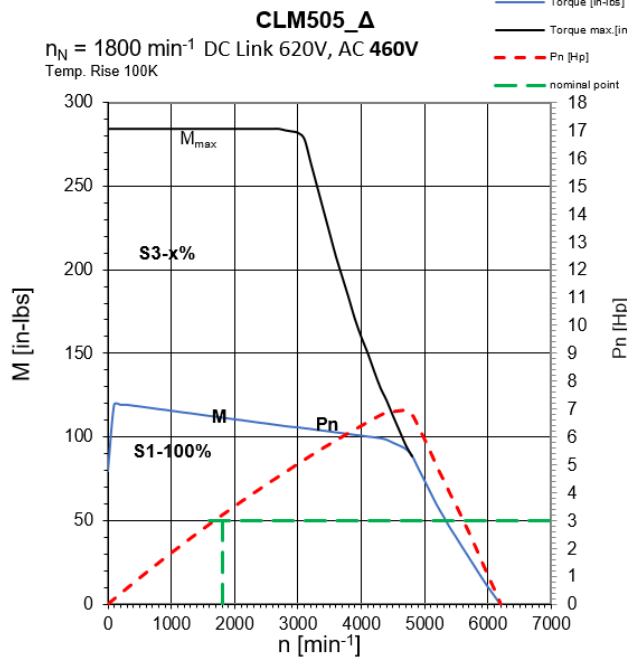
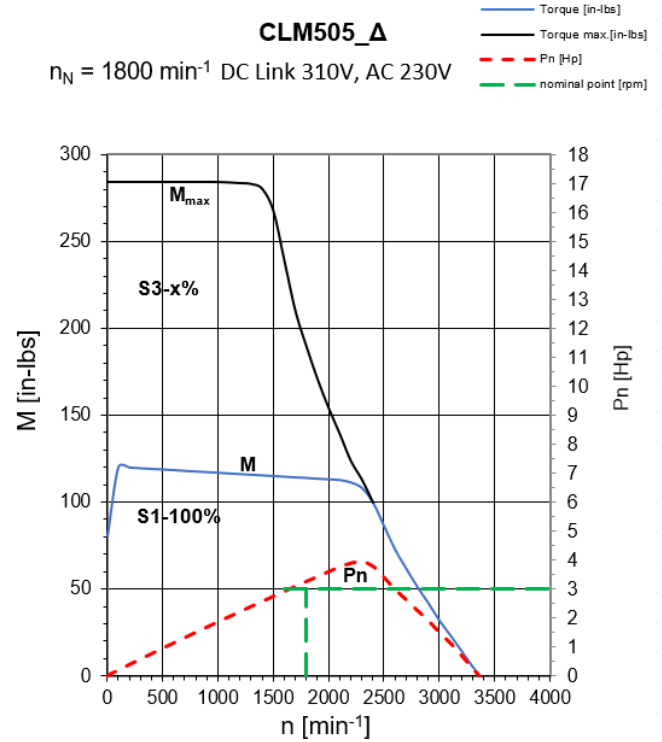
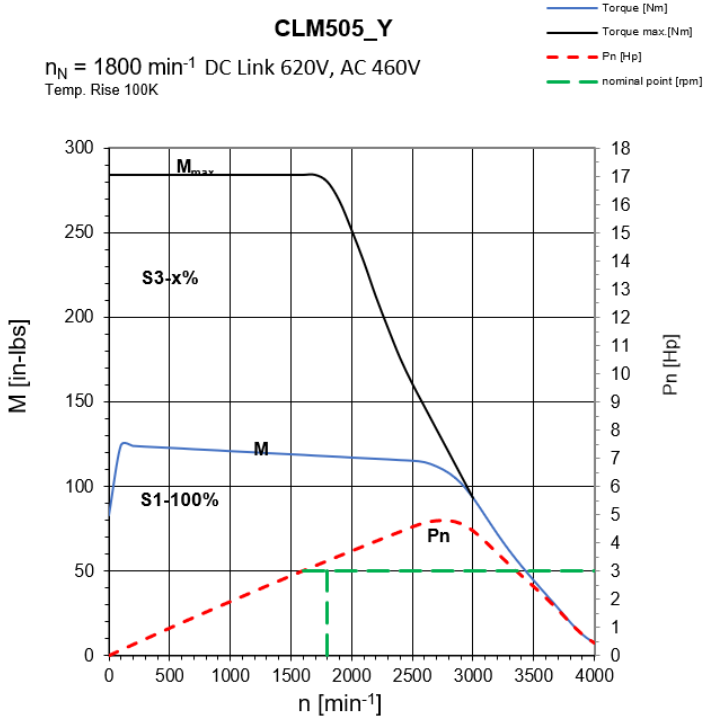

IP68 and IP69K CERTIFIED

cLEAN Motor Feet Option

cLEAN System

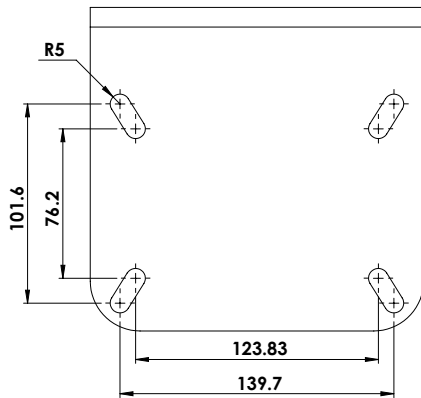
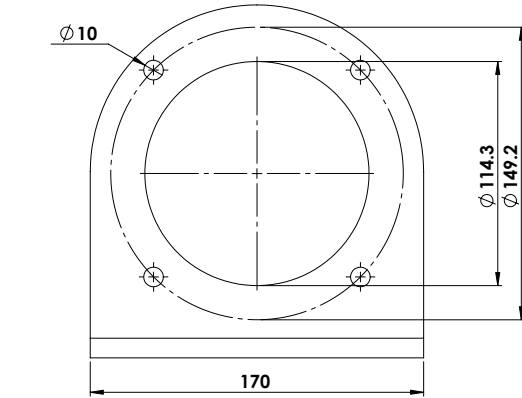

216266 - Frame Size 56C/143TC

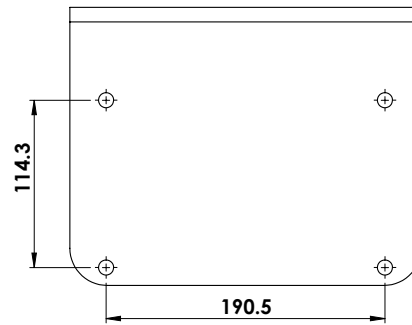
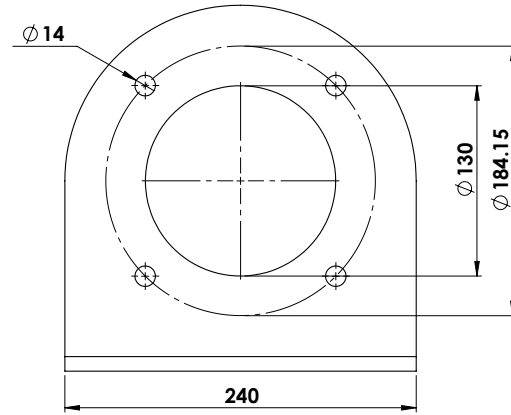

216269 - Frame Size 180

cLEAN Motor Feet Options

Kit Part Number	Parts included	Foot Plate	NEMA Frame Sizes
CS137636	4 x (3/8 – 16x7/8 UNC 18-8)	CLM50X	050 140
CS137637	4 x (1/2 – 13x1 UNC 18-8)	CLM50X	180

cLEAN System: CABLE

Features

- 4 power wires 14AWG size and 1 twisted pair of 16AWG size
- Braided Shielding > 85%
- Stainless Steel connector for quick disconnects

The cLEAN Cable is designed to withstand harsh environments. It is ECOLAB Certified, washdown environment rated, and contains braided shielding. Utilizing a stainless steel connector for quick disconnect, the motor will be up and running in no time.

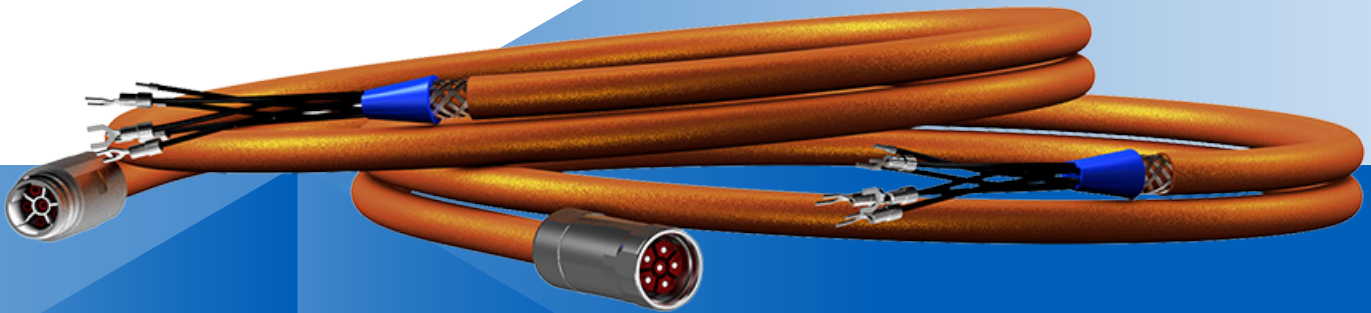

Benefits

- 3 year warranty
- Twisted pair shielded to maintain signal integrity
- Low-impedance signal return path prevents common-mode currents
- Flexible - suitable for drag chains
- Braided Shielding > 85%
- Excellent EMI/RFI noise reduction
- Washdown environment rated and tested
- DESINA Standard - Orange, RAL 2003
- ECOLAB Certified against various cleaning/disinfecting agents
- IP69k Certified when mated to prevent water and dust ingress
- Assembled in USA

Overview



Ordering Options At-a-Glance

Use the appropriate order codes below to build a part number for the complete assembly.

Part Number Example: **1** CP | **2** CMP1 | **3** 002.5M

	Design Option	Part Number Code	Description
1	Series	CP	Cable
2	Configuration	CMP1	2 options - 1 for flying leads or 23 for coupling with extension
3	Cable Length	002.5	Length of cable

CLEAN System

Cable Configuration Options

When ordering the cLEAN cable, you must select a connection configuration.

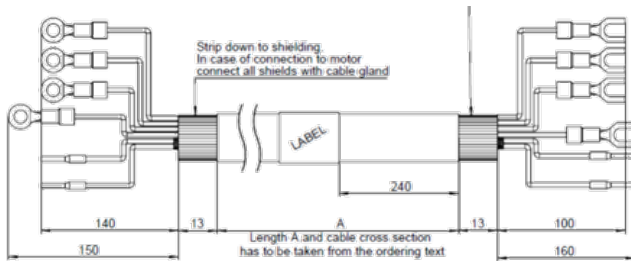

CMP1 - Flying Leads

the cable from the motor to the disconnect/drive

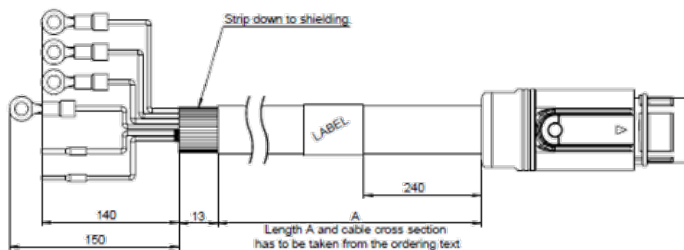

CMP2 - Coupling

works with CMP3 cable and runs from the motor

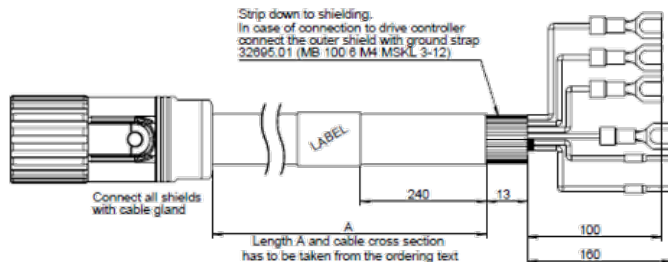

CMP3 - Extension

works with CMP2 cable and runs from the drive.

Table 1 Cable Length Options

Meters	Part Number
2.5	002.5
5.0	005.0
7.5	007.5
10.0	010.0
12.5	012.5
15	015.0
18	018.0
20	020.0
25	025.0
30	030.0
35	035.0
40	040.0
50	050.0
60	060.0
70	070.0
80	080.0
90	090.0
100	100.0

cLEAN System: DRIVE

Features

- Works with numerous communications protocols, including MODBUS, PROFIBUS, EtherCAT, and EtherNET/IP
- Removable keypad for remote operation away from the drive
- Removable RFI jumper for different application methods
- Built in Safe Torque Off (STO) Compliant with:
 - EN ISO 13849-1 Cat3/PLd
 - EN 60204-1 Category 0
 - EN 61508 SIL2
 - EN 62061 SIL CL 2
- 16 segment display and quick settings wheel for ease of navigation
- Removable fan for ease of service/replacement

The cLEAN Drive can be installed in minutes. Working with a variety of communication protocols, the cLEAN Drive is easy to program and service.



Benefits

- Protection against overcurrent, overvoltage, over-temperature, and phase failure
- Compact - saves valuable space in cabinet with no air gap
- Removable drive card for easy programming of new drive - no recommissioning
- Simple to program - less than 15 minutes
- 4 save slots for storing parameter sets on the removable keypad for reading/writing to the drive
- Built in USB port for fast and easy programming and real-time monitoring
- 5K built in PLC steps for distributed and independent operation
- Spring clamp terminals for control wires, saving time when wiring
- Assembled in USA



Overview

Ordering Options At-a-Glance

Use the appropriate order codes below to build a part number for the complete assembly.

Part Number Example: **1** **2** **3** **4** **5** **6** **7** **8** **9** **0**
VFD **5A0** **MH** **23** **A** **N** **S** **A** **A** **1**

Design Option	Part Number Code	Description
1 Product Category	VFD	Variable Frequency Drive
2 Rated Output Current	5A0	Rated output current (Ex: under heav duty mode, 150%, 60 seconds)
3 Series	MH	Version of speed drive (Ex: MH300)
4 Input Voltage	23	Options are 23 (230V 3-phase) or 43 (460V 3-phase)
5 Protection Level	A	IP20
	E	IP40
6 EMC Function	N	No function
	F	Built-in EMC filter
7 Safety Function	S	Built-in STO
8 Model Type	A	Standard
	N	Available for 3-phase 230V and 480V, 1HP drive without cooling fan
9 Generation	A	Version Type
0 Drive Horsepower*	1	1 HP
	2	2HP
	3	3HP

*Note: Drive Horsepower is added to "notes" section of order.

CLEAN System

cLEAN Drive

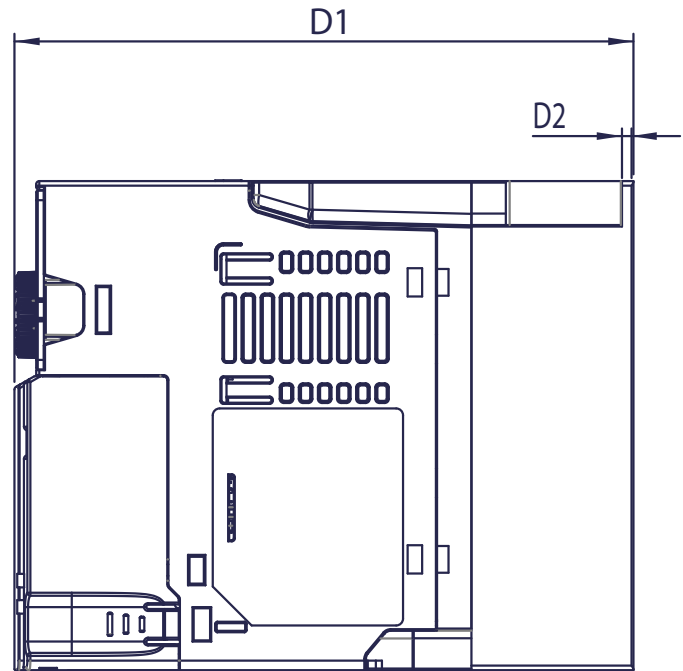
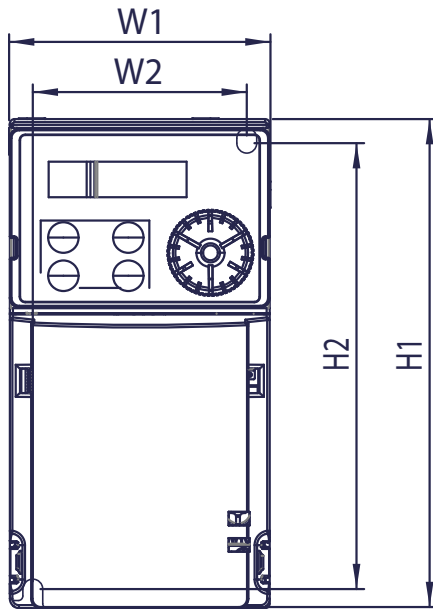

Table 1 cLEAN Drive – Dimensions (in)*

Base Module	W1	W2	H1	H2	D1	D2	S1
CLM502	2.68	2.2	5.04	4.65	5.91	0.12	0.2
CLM503	2.83	2.36	5.59	5.12	6.22	0.25	0.2
CLM505	3.43	2.87	6.18	5.69	6.57	0.2	0.22

*Dimensions for cLEAN Drive are the same for all communication protocols.

H2 are all dimensions with optional accessories

S1 dimension for mounting

KSS Series: RIGHT ANGLE — Solid Shaft/Hollow Output

KSS Series Features

- Input rating up to 5 HP
- Ratio options 4:1 – 272:1
- Output torque capability up to 4872 lb-in
- NEMA input capabilities of 56C, 143/145TC, 182/184TC
- All stainless steel hardware
- Output bore diameters up to 1-1/2"
- Housing style options: feet, flange, torque arm bracket, or tapped holes

The KSS Series utilizes our quality-proven, high-efficiency K Series helical/bevel speed reducer mechanics. Enclosed within a sealed, stainless steel housing, the KSS provides superior performance for food duty and severe wash down applications.

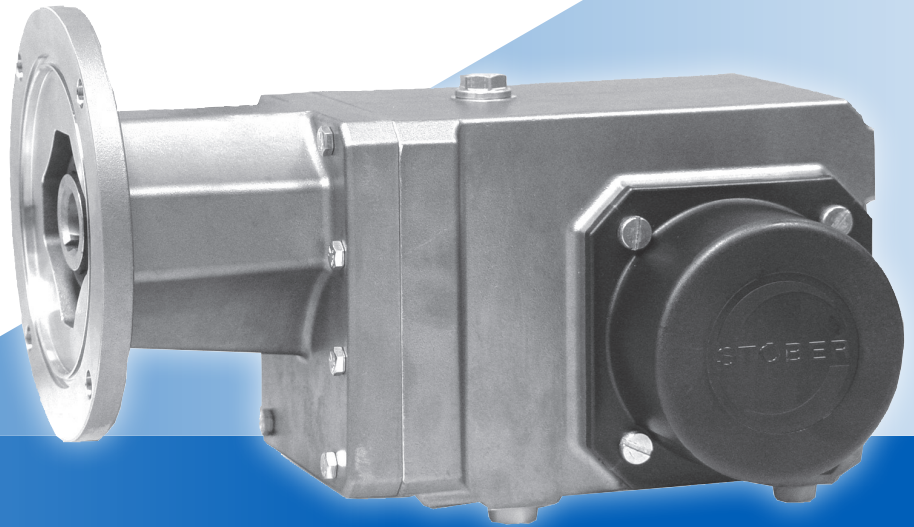

**SHIPS in
1 DAY!**
NO EXPEDITE FEE FOR 24
HOUR SERVICE

KSS Series Benefits

- No maintenance - totally enclosed with no breather to allow contaminants in or oil out
- Lubricated for life with Mobil SHC CIBUS 220 food grade oil
- No harborage point for bacteria because of our laser etched nameplate data
- Simple motor mounting and removal with Bowex coupling system
- Energy savings - up to 97% efficiency
- Easy installation and removal with our patented bushing system and any horizontal mounting position
- Reliability guaranteed with 3 year warranty
- Adaptability - mounting gear reducer from either machine side means stocking fewer options
- Durability - IP69K Certified to prevent water and dust ingress
- Assembled in USA

The Optimum Food & Beverage Solution!

- Cast stainless steel housing outside; all stainless steel hardware inside
- Mobil SHC CIBUS 220 food grade oil
- Suitable for the most extreme wash down applications
- USDA Accepted Equipment/FDA compliant
- IP69K certified to prevent water and dust ingress (see page 6 for full details)

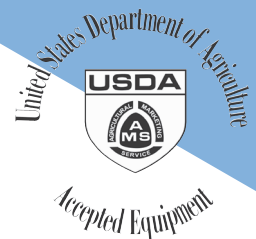

Overview

IP69K/STAINLESS STEEL

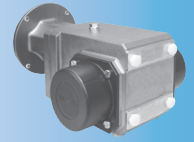

KSS Ordering Options At-a-Glance

KSS Series are available in a wide range of user-selected design options that tailor the speed reducer to your motor and exact application requirements. Use the appropriate order codes below to build a part number for the complete assembly.

Part Number Example: 1 2 3 4 5 6 7 8 9 0*

Part Number Example: KSS 1 0 2 W G 0040 MS1R 050 E1256

	Part Number		
Design Option	Code		Description
1 Series	KSS		Stainless steel housing; right angle helical/bevel
2 Size	1 2 3 4		4 sizes of speed reducers
3 Generation	0		Version of speed reducers
4 # of Stages	2 3		Two stage or three stage
5 Output	A		Hollow bore output
	V		Solid shaft output (specify side 3, 4 or double sided)
	W		Double wobble-free bushing
6 Housing	F		Round output flange (specify side 3 or 4)
	G		Pilot Circle Diameter (PCD) tapped holes
	GD		Torque arm bracket
	NG		Foot mounting (specify side 1 or 5)
7 Ratio	0040		Ratios range from 4:1 to 272:1 (refer to Selection Data tables)
	MS1R		For KSS1
8 Motor Adapter	MS2R		For KSS2
	MS3R		For KSS3
	MS4R		For KSS4
	050		56C
9 NEMA Frame Size	140		143/145TC
	180		182/184TC
	0		
Mounting Position* <i>Refer to page 62 illustrations</i>	EL1256		Mounting positions for 3 year warranty
	E34		

*Note: Mounting position is added to "notes" section of order.

Output and Housing Configurations

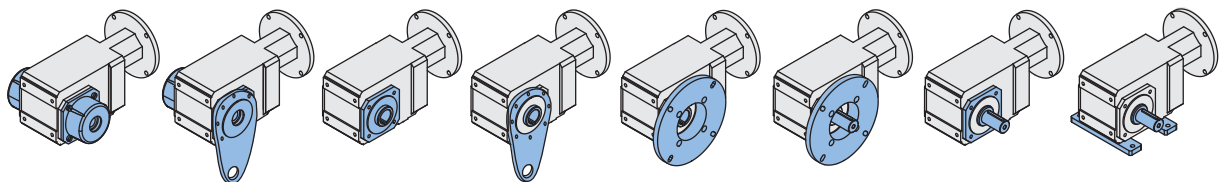

See Page	page 70	page 71	page 72	page 73	page 74	page 75	page 76	page 77
Output	W Double Bushing	W Double Bushing	A Hollow Bore	A Hollow Bore	A Hollow Bore	V Solid Shaft	V Solid Shaft	V Solid Shaft
Housing	G Tapped Holes	GD Torque Arm Bracket	G Tapped Holes	GD Torque Arm Bracket	F Round Flange	F Round Flange	G Tapped Holes	NG Foot Mount

KSS Series: RIGHT ANGLE — Solid Shaft / Hollow Output

KSS Series: RIGHT ANGLE — Solid Shaft/Hollow Output

KSS Series Orientation

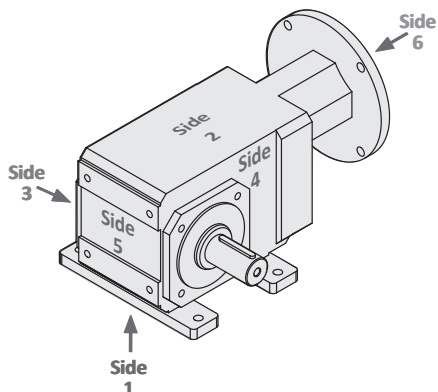

KSS Series Direction of Rotation

Output available on side 3, 4 or both.
 Note: With a double output, the shaft rotation of Side 3 will be the OPPOSITE direction of Side 4 when viewed from Side 5.

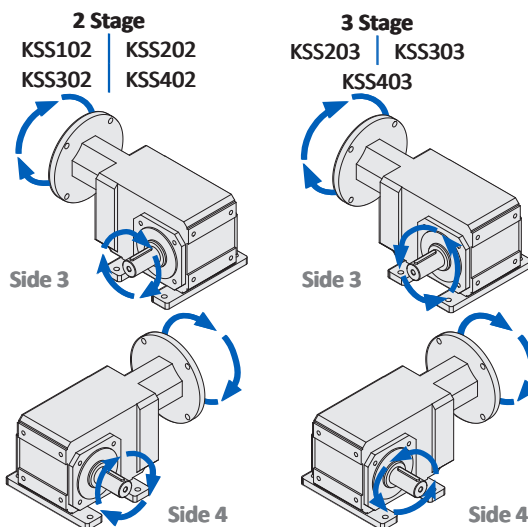

KSS Series Output Options

BLUE: standard output diameters in stock
 BLACK: optional diameters in stock

All Outputs Stainless Steel (Inches)		KSS1	KSS2	KSS3	KSS4
"V" Solid Shaft	Inches	1	1-1/4	1-1/4	1-3/8
"A" Hollow Bore	Inches	1	1-1/4	1-3/8	1-1/2
"W" Wobble Free Bushing	Inches	1	1 1-3/16 1-1/4 1-3/8 1-7/16 1-1/2	1 1-3/16 1-1/4 1-3/8 1-7/16 1-1/2	1-3/16 1-1/4 1-3/8 1-7/16 1-1/2
	Metric	25	30 35	30 35	40

KSS Mounting Position Options

When ordering any KSS unit, the mounting position must be specified. Use one of the mounting position order codes illustrated below that corresponds to the intended application.

Note that KSS units are equipped with specialized seals, higher oil level, and additional features that enables all horizontal output positions to be used interchangeably.

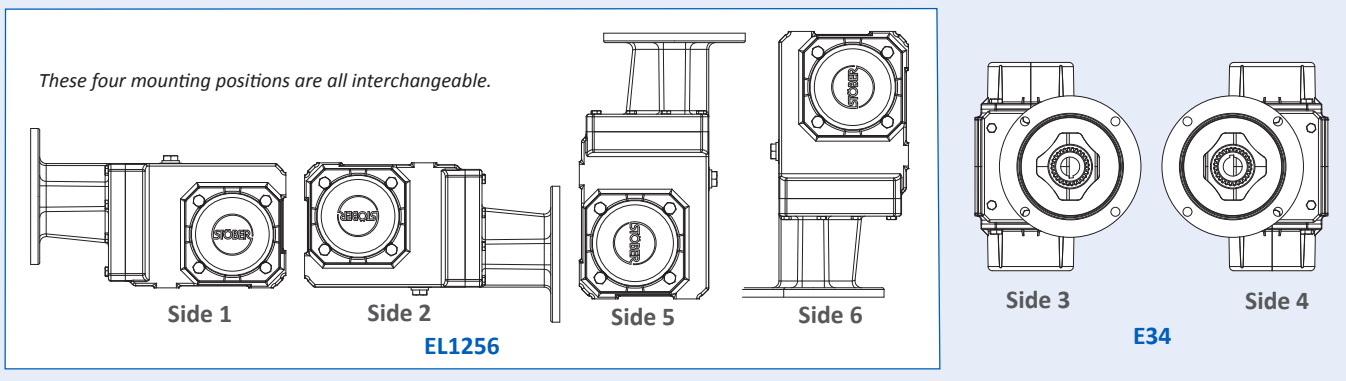

Permissible Motor Tilting Torque

The permissible tilting torque of the motor attached to the gear unit is a result of the static and dynamic load "F" from the motor weight, mass acceleration, and vibration multiplied by the distance from the center of gravity "I_s" of the motor.

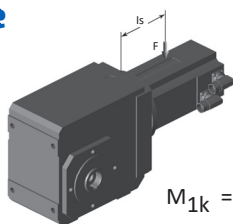

$$M_{1k} = F \times I_s \leq M_{1K}$$

M _{1K}	MS1R	MS2R	MS3R	MS4R
in.lbs	221	531	1106	2212

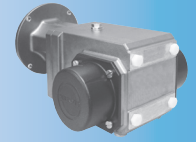

Selection Data

IP69K/STAINLESS STEEL

KSS Series: RIGHT ANGLE — Solid Shaft / Hollow Output

KSS Sizing/Selection:

1. Find the **RPM Output (Approximate)** nearest the application requirement. (If the exact Output RPM is required, divide the Input RPM [1750] by the value listed in the Nominal Ratio column.)
- 2a. In the **Input HP** column, locate the rating that is greater than or equal to the required HP, or;
- 2b. If selection is based on Torque instead of HP, find an **Output Torque** that is equal to or greater than required.
3. Confirm that the **Overhung Load** is acceptable for the application.
4. Choose the appropriate **Base Module** and **Motor Adapter** part number code (see page 61 for complete ordering information).

1750 RPM Input		Nominal Ratio	Overhung Load Output Shaft ¹⁾ (lbs)	Part Number Codes (in blue)		Compatible NEMA C-Frame ²⁾ with Designated Motor Adapter
Input HP	Output Torque (lb-in)			Base Module	Motor Adapter	
435 RPM Output (Approximate)						
2.61	364	4.000	402	KSS102_0040	MS1R050	56C
7.00*	979	4.000	483	KSS202_0040	MS2R050	56C
					MS2R140	143/145TC
9.22*	1,289	4.000	563	KSS302_0040	MS3R050	56C
					MS3R140	143/145TC
					MS3R180	182/184TC
9.22	1,289	4.000	901	KSS402_0040	MS4R050	56C
					MS4R140	143/145TC
18.40*	2,572	4.000	901	KSS402_0040	MS4R180	182/184TC
340 RPM Output (Approximate)						
5.89*	1,067	5.177	526	KSS202_0052	MS2R050	56C
					MS2R140	143/145TC
325 RPM Output (Approximate)						
8.73*	1,640	5.375	621	KSS302_0054	MS3R050	56C
					MS3R140	143/145TC
10.07*	1,892	5.375	621	KSS302_0054	MS3R180	182/184TC
9.22	1,747	5.422	997	KSS402_0054	MS4R050	56C
					MS4R140	143/145TC
15.02*	2,847	5.422	997	KSS402_0054	MS4R180	182/184TC
315 RPM Output (Approximate)						
2.61	507	5.568	449	KSS102_0056	MS1R050	56C
260 RPM Output (Approximate)						
2.61	605	6.644	476	KSS102_0066	MS1R050	56C
245 RPM Output (Approximate)						
4.77	1,186	7.118	585	KSS202_0071	MS2R050	56C
					MS2R140	143/145TC

1) Overhung Load is measured at the center of the shaft extension. Hollow output units are not intended to support overhung loads. If a load rating is required, use 50% of the published overhung load.

2) Motor HP for TEFC NEMA C-Frame @ 1750 RPM

C-Frame	56C	143/145TC	182/184
HP	1/4 to 1-1/2	1 to 2	3 to 5

* Thermal HP Limit

Base Module Size	KSS102	KSS202	KSS302	KSS402
HP Limit	2.95	5.36	7.38	12.34

KSS Series: RIGHT ANGLE — Solid Shaft/Hollow Output

1750 RPM Input		Nominal Ratio	Overhung Load Output Shaft ¹⁾ (lbs)	Part Number Codes (in blue)		Compatible NEMA C-Frame ²⁾ with Designated Motor Adapter
Input HP	Output Torque (lb-in)			Base Module	Motor Adapter	
235 RPM Output (Approximate)						
8.14*	2,104	7.391	691	KSS302_0074	MS3R050	56C
					MS3R140	143/145TC
					MS3R180	182/184TC
9.22	2,402	7.456	1,109	KSS402_0075	MS4R050	56C
					MS4R140	143/145TC
12.04	3,166	7.456	1,109	KSS402_0075	MS4R180	182/184TC
210 RPM Output (Approximate)						
4.27	1,253	8.397	618	KSS202_0084	MS2R050	56C
					MS2R140	143/145TC
6.87	2,029	8.444	722	KSS302_0084	MS3R050	56C
					MS3R140	143/145TC
7.45	2,199	8.444	722	KSS302_0084	MS3R180	182/184TC
7.70	2,256	8.377	1,153	KSS402_0084	MS4R050	56C
					MS4R140	143/145TC
11.24	3,291	8.377	1,153	KSS402_0084	MS4R180	182/184TC
190 RPM Output (Approximate)						
2.24	725	9.249	532	KSS102_0092	MS1R050	56C
170 RPM Output (Approximate)						
2.11	747	10.140	548	KSS102_0100	MS1R050	56C
3.78	1,332	10.073	657	KSS202_0100	MS2R050	56C
					MS2R140	143/145TC
5.98	2,117	10.135	768	KSS302_0100	MS3R050	56C
					MS3R140	143/145TC
6.60	2,337	10.135	768	KSS302_0100	MS3R180	182/184TC
6.66	2,351	10.098	1,227	KSS402_0100	MS4R050	56C
					MS4R140	143/145TC
9.62	3,503	10.098	1,227	KSS402_0100	MS4R180	182/184TC

1) Overhung Load is measured at the center of the shaft extension. Hollow output units are not intended to support overhung loads. If a load rating is required, use 50% of the published overhung load.

2) Motor HP for TEFC NEMA C-Frame @ 1750 RPM

C-Frame	56C	143/145TC	182/184
HP	1/4 to 1-1/2	1 to 2	3 to 5

* Thermal HP Limit

Base Module Size	KSS102	KSS202	KSS302	KSS402
HP Limit	2.95	5.36	7.38	12.34

Selection Data

IP69K/STAINLESS STEEL

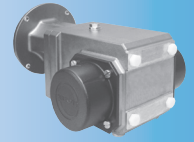

1750 RPM Input		Nominal Ratio	Overhung Load Output Shaft ¹⁾ (lbs)	Part Number Codes (in blue)		Compatible NEMA C-Frame ²⁾ with Designated Motor Adapter
Input HP	Output Torque (lb-in)			Base Module	Motor Adapter	

150 RPM Output (Approximate)

3.45	1,394	11.546	687	KSS202_0115	MS2R050	56C
					MS2R140	143/145TC
6.02	2,445	11.610	803	KSS302_0115	MS3R050	56C
					MS3R140	143/145TC
					MS3R180	182/184TC
7.70	3,102	11.518	1,282	KSS402_0115	MS4R050	56C
					MS4R140	143/145TC
9.09	3,660	11.518	1,282	KSS402_0115	MS4R180	182/184TC

140 RPM Output (Approximate)

3.24	1,439	12.705	710	KSS202_0125	MS2R050	56C
					MS2R140	143/145TC
5.12	2,251	12.577	825	KSS302_0125	MS3R050	56C
					MS3R140	143/145TC
5.71	2,511	12.577	825	KSS302_0125	MS3R180	182/184TC
					MS4R050	56C
5.86	2,594	12.658	1,323	KSS402_0125	MS4R140	143/145TC
					MS4R180	182/184TC
8.53	3,777	12.658	1,323	KSS402_0125	MS4R180	182/184TC

125 RPM Output (Approximate)

1.69	835	14.114	612	KSS102_0140	MS1R050	56C
3.06	1,481	13.851	730	KSS202_0140	MS2R050	56C
					MS2R140	143/145TC
5.33	2,599	13.935	854	KSS302_0140	MS3R050	56C
					MS3R140	143/145TC
					MS3R180	182/184TC
6.66	3,232	13.885	1,364	KSS402_0140	MS4R050	56C
					MS4R140	143/145TC
8.02	3,895	13.885	1,364	KSS402_0140	MS4R180	182/184TC

105 RPM Output (Approximate)

1.51	883	16.714	648	KSS102_0165	MS1R050	56C
4.03	2,389	16.939	911	KSS302_0170	MS3R050	56C
					MS3R140	143/145TC
4.68	2,774	16.939	911	KSS302_0170	MS3R180	182/184TC

1) Overhung Load is measured at the center of the shaft extension. Hollow output units are not intended to support overhung loads. If a load rating is required, use 50% of the published overhung load.

2) Motor HP for TEFC NEMA C-Frame @ 1750 RPM

C-Frame	56C	143/145TC	182/184
HP	1/4 to 1-1/2	1 to 2	3 to 5

KSS Series: RIGHT ANGLE — Solid Shaft / Hollow Output

KSS Series: RIGHT ANGLE — Solid Shaft/Hollow Output

1750 RPM Input		Nominal Ratio	Overhung Load Output Shaft ¹⁾ (lbs)	Part Number Codes (in blue)		Compatible NEMA C-Frame ²⁾ with Designated Motor Adapter
Input HP	Output Torque (lb-in)			Base Module	Motor Adapter	
100 RPM Output (Approximate)						
2.62	1,600	17.469	789	KSS202_0175	MS2R050	56C
					MS2R140	143/145TC
4.62	2,793	17.293	917	KSS302_0175	MS3R050	56C
					MS3R140	143/145TC
					MS3R180	182/184TC
5.86	3,567	17.405	1,471	KSS402_0175	MS4R050	56C
					MS4R140	143/145TC
6.90	4,200	17.405	1,471	KSS402_0175	MS4R180	182/184TC

85 RPM Output (Approximate)

1.33	940	20.150	690	KSS102_0200	MS1R050	56C
2.37	1,683	20.327	830	KSS202_0200	MS2R050	56C
					MS2R140	143/145TC
3.56	2,526	20.278	967	KSS302_0200	MS3R050	56C
					MS3R140	143/145TC
4.15	2,945	20.278	967	KSS302_0200	MS3R180	182/184TC
4.03	2,849	20.197	1,546	KSS402_0200	MS4R050	56C
					MS4R140	143/145TC
6.25	4,413	20.197	1,546	KSS402_0200	MS4R180	182/184TC

75 RPM Output (Approximate)

1.21	986	23.265	723	KSS102_0230	MS1R050	56C
3.79	3,084	23.292	1,013	KSS302_0230	MS3R050	56C
					MS3R140	143/145TC
					MS3R180	182/184TC

70 RPM Output (Approximate)

0.96	851	25.220	743	KSS102_0250	MS1R050	56C
2.02	1,772	25.130	891	KSS202_0250	MS2R050	56C
					MS2R140	143/145TC
2.91	2,566	25.259	1,041	KSS302_0250	MS3R050	56C
					MS3R140	143/145TC
3.48	3,070	25.259	1,041	KSS302_0250	MS3R180	182/184TC
3.34	2,956	25.279	1,666	KSS402_0250	MS4R050	56C
					MS4R140	143/145TC
5.02	4,434	25.279	1,666	KSS402_0250	MS4R180	182/184TC

1) Overhung Load is measured at the center of the shaft extension. Hollow output units are not intended to support overhung loads. If a load rating is required, use 50% of the published overhung load.

2) Motor HP for TEFC NEMA C-Frame @ 1750 RPM

C-Frame	56C	143/145TC	182/184
HP	1/4 to 1-1/2	1 to 2	3 to 5

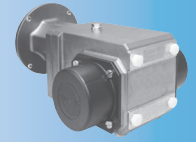

Selection Data

IP69K/STAINLESS STEEL

1750 RPM Input		Nominal Ratio	Overhung Load Output Shaft ¹⁾ (lbs)	Part Number Codes (in blue)		Compatible NEMA C-Frame ²⁾ with Designated Motor Adapter
Input HP	Output Torque (lb-in)			Base Module	Motor Adapter	

60 RPM Output (Approximate)

1.07	1,049	28.048	770	KSS102_0280	MS1R050	56C
1.81	1,772	27.950	923	KSS202_0280	MS2R050	56C
					MS2R140	143/145TC
3.18	3,100	27.883	1,076	KSS302_0280	MS3R050	56C
					MS3R140	143/145TC
					MS3R180	182/184TC
4.03	3,917	27.771	1,719	KSS402_0280	MS4R050	56C
					MS4R140	143/145TC
5.02	4,872	27.771	1,719	KSS402_0280	MS4R180	182/184TC

55 RPM Output (Approximate)

2.76	3,100	32.649	1,134	KSS303_0330	MS3R050	56C
					MS3R140	143/145TC
3.34	3,733	32.390	1,809	KSS403_0320	MS4R050	56C
					MS4R140	143/145TC

52 RPM Output (Approximate)

0.55	647	33.707	886	KSS102_0340	MS1R050	56C
1.16	1,364	33.618	1,063	KSS202_0340	MS2R050	56C
					MS2R140	143/145TC
1.89	2,217	33.618	1,240	KSS302_0340	MS3R050	56C
					MS3R140	143/145TC
					MS4R050	56C
2.62	3,084	33.678	1,833	KSS402_0340	MS4R140	143/145TC
					MS4R180	182/184TC
2.93	3,445	33.678	1,833	KSS402_0340	MS4R180	182/184TC

50 RPM Output (Approximate)

0.87	1,063	35.105	895	KSS102_0350	MS1R050	56C
1.47	1,772	34.554	1,070	KSS202_0350	MS2R050	56C
					MS2R140	143/145TC
2.55	3,100	34.731	1,250	KSS302_0350	MS3R050	56C
					MS3R140	143/145TC
					MS4R050	56C
3.34	4,065	34.758	1,852	KSS402_0350	MS4R140	143/145TC
					MS4R180	182/184TC
4.01	4,872	34.758	1,852	KSS402_0350	MS4R180	182/184TC

45 RPM Output (Approximate)

1.30	1,772	39.454	1,035	KSS203_0390	MS2R050	56C
2.30	3,100	39.187	1,288	KSS303_0390	MS3R050	56C
					MS3R140	143/145TC
3.34	4,500	39.047	1,926	KSS403_0390	MS4R050	56C
					MS4R140	143/145TC

1) Overhung Load is measured at the center of the shaft extension. Hollow output units are not intended to support overhung loads. If a load rating is required, use 50% of the published overhung load.

2) Motor HP for TEFC NEMA C-Frame @ 1750 RPM

C-Frame	56C	143/145TC	182/184
HP	1/4 to 1-1/2	1 to 2	3 to 5

KSS Series: RIGHT ANGLE — Solid Shaft / Hollow Output

KSS Series: RIGHT ANGLE — Solid Shaft/Hollow Output

1750 RPM Input		Nominal Ratio	Overhung Load Output Shaft ¹⁾ (lbs)	Part Number Codes (in blue)		Compatible NEMA C-Frame ²⁾ with Designated Motor Adapter
Input HP	Output Torque (lb-in)			Base Module	Motor Adapter	
43 RPM Output (Approximate)						
0.39	544	40.300	927	KSS102_0400	MS1R050	56C
1.20	1,705	40.512	1,299	KSS302_0410	MS3R050	56C
					MS3R140	143/145TC
1.93	2,729	40.512	1,950	KSS402_0410	MS4R050	56C
					MS4R140	143/145TC
40 RPM Output (Approximate)						
1.10	1,772	46.225	1,151	KSS202_0460	MS2R050	56C
					MS2R140	143/145TC
1.89	3,048	46.225	1,343	KSS302_0460	MS3R050	56C
					MS3R140	143/145TC
2.01	3,100	44.892	1,333	KSS303_0450	MS3R050	56C
					MS3R140	143/145TC
2.92	4,736	46.308	2,038	KSS402_0460	MS4R050	56C
					MS4R140	143/145TC
3.17	4,872	44.536	2,012	KSS403_0450	MS4R050	56C
					MS4R140	143/145TC
35 RPM Output (Approximate)						
0.55	900	46.918	963	KSS102_0470	MS1R050	56C
1.03	1,772	49.759	1,118	KSS203_0500	MS2R050	56C
1.85	3,100	48.631	1,360	KSS303_0490	MS3R050	56C
					MS3R140	143/145TC
2.89	4,872	48.944	2,076	KSS403_0490	MS4R050	56C
					MS4R140	143/145TC
30 RPM Output (Approximate)						
0.38	753	56.095	970	KSS102_0560	MS1R050	56C
0.95	1,772	54.25	1,151	KSS203_0540	MS2R050	56C
1.20	2,345	55.705	1,407	KSS302_0560	MS3R050	56C
					MS3R140	143/145TC
1.67	3,100	53.883	1,395	KSS303_0540	MS3R050	56C
					MS3R140	143/145TC
1.93	3,752	55.705	2,168	KSS402_0560	MS4R050	56C
					MS4R140	143/145TC
2.63	4,872	53.690	2,141	KSS403_0540	MS4R050	56C
					MS4R140	143/145TC

1) Overhung Load is measured at the center of the shaft extension. Hollow output units are not intended to support overhung loads. If a load rating is required, use 50% of the published overhung load.

2) Motor HP for TEFC NEMA C-Frame @ 1750 RPM

C-Frame	56C	143/145TC	182/184
HP	1/4 to 1-1/2	1 to 2	3 to 5

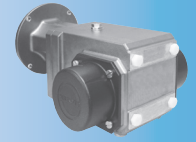

Selection Data

IP69K/STAINLESS STEEL

1750 RPM Input		Nominal Ratio	Overhung Load Output Shaft ¹⁾ (lbs)	Part Number Codes (in blue)		Compatible NEMA C-Frame ²⁾ with Designated Motor Adapter
Input HP	Output Torque (lb-in)			Base Module	Motor Adapter	
27 RPM Output (Approximate)						
1.38	3,100	65.499	1,465	KSS303_0650	MS3R050	56C
					MS3R140	143/145TC
25 RPM Output (Approximate)						
0.75	1,772	68.419	1,244	KSS203_0680	MS2R050	56C
1.35	3,100	66.868	1,473	KSS303_0670	MS3R050	56C
					MS3R140	143/145TC
22 RPM Output (Approximate)						
0.65	1,772	79.615	1,308	KSS203_0800	MS2R050	56C
1.15	3,100	78.410	1,532	KSS303_0780	MS3R050	56C
					MS3R140	143/145TC
1.81	4,872	78.095	2,426	KSS403_0780	MS4R050	56C
					MS4R140	143/145TC
19 RPM Output (Approximate)						
1.00	3,100	90.061	1,575	KSS303_0900	MS3R050	56C
					MS3R140	143/145TC
16 RPM Output (Approximate)						
0.47	1,772	109.471	1,350	KSS203_1090	MS2R050	56C
0.84	3,100	107.814	1,575	KSS303_1080	MS3R050	56C
					MS3R140	143/145TC
1.32	4,872	107.381	2,520	KSS403_1070	MS4R050	56C
					MS4R140	143/145TC
13 RPM Output (Approximate)						
0.38	1,772	135.335	1,350	KSS203_1350	MS2R050	56C
0.67	3,100	134.292	1,575	KSS303_1340	MS3R050	56C
					MS4R050	56C
1.05	4,872	134.399	2,520	KSS403_1340	MS4R140	143/145TC
10 RPM Output (Approximate)						
0.28	1,772	181.048	1,350	KSS203_1810	MS2R050	56C
0.50	3,048	178.737	1,575	KSS303_1790	MS3R050	56C
					MS4R050	56C
0.77	4,737	179.056	2,520	KSS403_1790	MS4R050	56C
8 RPM Output (Approximate)						
0.51	3,752	215.391	2,520	KSS403_2150	MS4R050	56C

KSS Series: RIGHT ANGLE — Solid Shaft / Hollow Output

1) Overhung Load is measured at the center of the shaft extension. Hollow output units are not intended to support overhung loads. If a load rating is required, use 50% of the published overhung load.

2) Motor HP for TEFC NEMA C-Frame @ 1750 RPM

C-Frame	56C	143/145TC	182/184
HP	1/4 to 1-1/2	1 to 2	3 to 5

KSS Series: RIGHT ANGLE — Solid Shaft/Hollow Output

“W” Double Bushing Output with “G” Pilot Circle Diameter (PCD) Tapped Holes

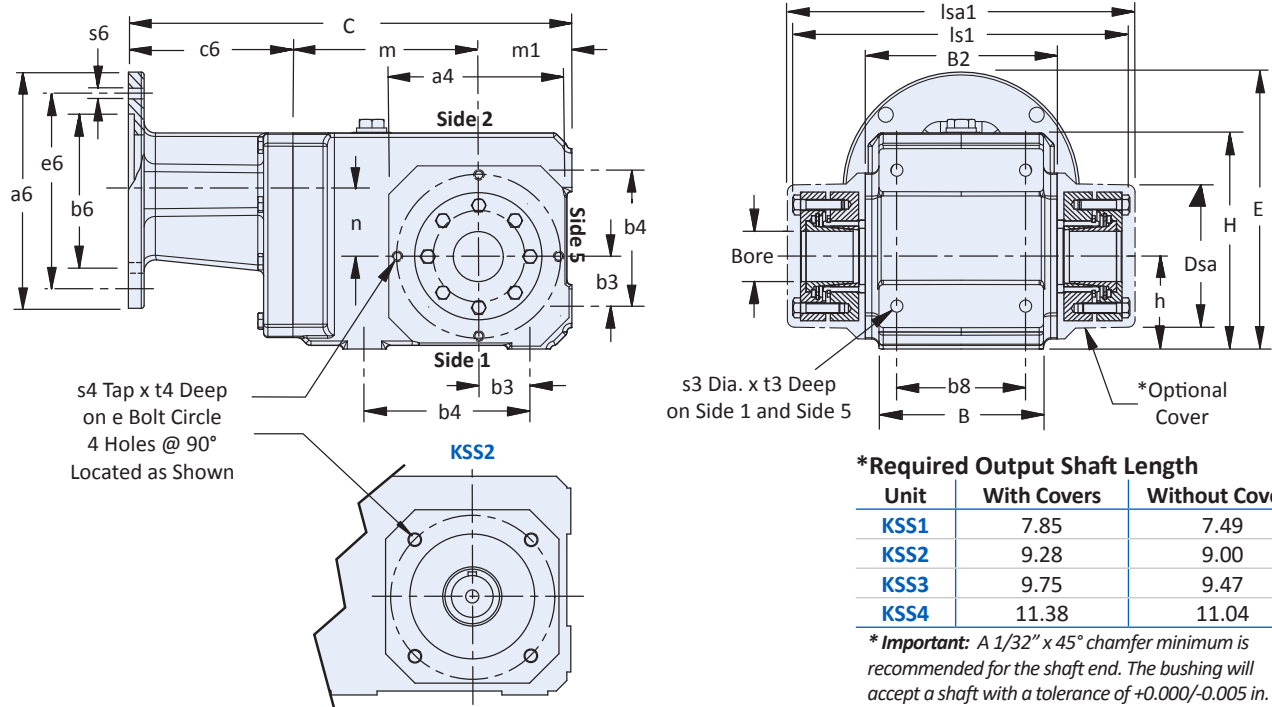

Table 1 KSS Series – “W” Double Wobble-Free Bushing Output with “G” Pilot Circle Diameter (PCD) Tapped Holes – Dimensions (in)

Base Module	a4	B2	b3	b4	b7	b8	Dsa	e	H	h	ls1	lsa1	m1	s3	s4	t3	t4
KSS1	4.53	4.17	1.18	3.54	2.95	2.76	3.07	3.54	4.96	2.36	7.64	7.80	2.36	M8x1.25	M8x1.25	0.51	0.51
KSS2	4.57	5.28	1.38	4.53	3.74	3.54	3.92	4.53	5.94	2.56	8.90	9.36	2.56	M10x1.50	M8x1.25	0.63	0.51
KSS3	5.20	5.75	1.38	5.12	4.13	4.13	3.78	4.53	6.56	2.95	9.41	9.95	2.95	M10x1.50	M8x1.25	0.63	0.55
KSS4	5.99	6.81	1.97	6.10	5.00	4.72	4.33	5.12	7.89	3.54	11.06	11.60	3.54	M12x1.75	M10x1.5	0.75	0.63

Table 2 KSS Series – “WG” Style Motor Adapter Dimensions (in)

Base Module	NEMA C-Face	a6	B	b6	C	c6	E	e6	m	n	s6	Wt. lbs
KSS102WG_MS1R050	56C	6.50	3.54	4.500	10.55	3.81	7.03	5.87	4.38	1.42	0.41	29
KSS202WG_MS2R050	56C	6.50	4.41	4.500	12.20	4.53	7.62	5.87	5.11	1.81	0.41	40
KSS202WG_MS2R140	143/145TC	6.50	4.41	4.500	12.20	4.53	7.62	5.87	5.11	1.81	0.41	40
KSS203WG_MS2R050	56C	6.50	4.53	4.500	13.07	3.31	6.64	5.87	7.20	0.83	0.41	53
KSS302WG_MS3R050	56C	6.50		4.500	13.23	4.37		5.87	5.91	2.09	0.41	55
KSS302WG_MS3R140	143/145TC	6.50	5.51	4.500	13.23	4.37	8.29	5.87	5.91	2.09	0.41	55
KSS302WG_MS3R180	182/184TC	9.00		8.500	14.57	6.59		7.25	5.03	2.07	0.55	67
KSS303WG_MS3R050	56C	6.50	5.51	4.500	15.22	4.00	6.83	5.87	8.27	0.63	0.41	55
KSS303WG_MS3R140	143/145TC	6.50	5.51	4.500	15.22	4.00	6.83	5.87	8.27	0.63	0.41	55
KSS402WG_MS4R050	56C	6.50		4.500	14.76	4.53	9.96	5.87			0.41	84
KSS402WG_MS4R140	143/145TC	6.50	5.71	4.500	14.76	4.53	9.96	5.87	6.69	2.36	0.41	84
KSS402WG_MS4R180	182/184TC	9.00		8.500	15.79	5.55	10.91	7.25			0.55	89
KSS403WG_MS4R050	56C	6.50	5.71	4.500	16.46	3.86	8.39	5.87	9.06	0.98	0.41	94
KSS403WG_MS4R140	143/145TC	6.50	5.71	4.500	16.46	3.86	8.39	5.87	9.06	0.98	0.41	94

Table 3 “WFBSS” Double Side Bushings Stock Bore Sizes

Base Module	Inches						Metric – mm
	1	1-3/16	1-1/4	1-3/8	1-7/16	1-1/2	40
KSS1	WFBSS1-100	—	—	—	—	—	—
KSS2	WFBSS2-100	WFBSS2-103	WFBSS2-104	WFBSS2-106	WFBSS2-107	WFBSS2-108	—
KSS3	WFBSS3-100	WFBSS3-103	WFBSS3-104	WFBSS3-106	WFBSS3-107	WFBSS3-108	—
KSS4	—	—	WFBSS4-104	—	WFBSS4-107	WFBSS4-108	—

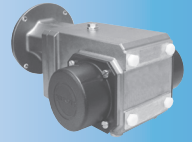

“W” Double Bushing Output with “GD” Torque Arm Bracket

Refer to page 70 for all other dimensions

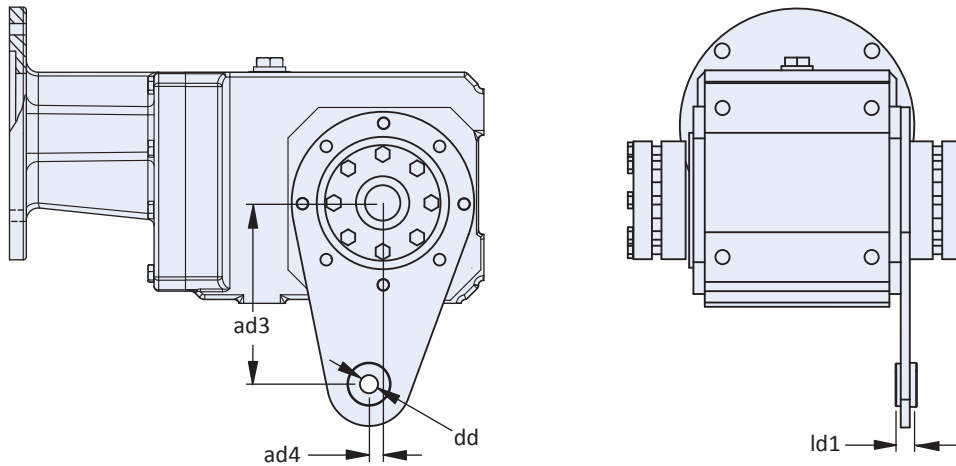

Table 4 “GD” Torque Arm

Base Module	Kit Number	mm			
		ad3	ad4	dd	ld1
KSS1	CS213227	130	10	13	15
KSS2	CS129573	130	10	13	15
KSS3	CS129573	130	10	13	15
KSS4	CS139679	130	10	13	15

Note: a bushing output plastic cover cannot be used on the Torque Arm side of speed reducer. A plastic cover can only be used on the side opposite the torque arm.

“W” Double Bushing Output with torque arm stabilizer bracket

KIT PART NUMBERS

CS137450 (205/206 Flanged Bearing)

CS137367 (207/208 Flanged Bearing)

Required Shaft Lengths

Wobble Free Bushing Length

Unit/Flange Bearing	205/206	207/208
KSS1	10.20	-
KSS2	11.4	11.94
KSS3	10.87	12.42
KSS4	13.19	13.73

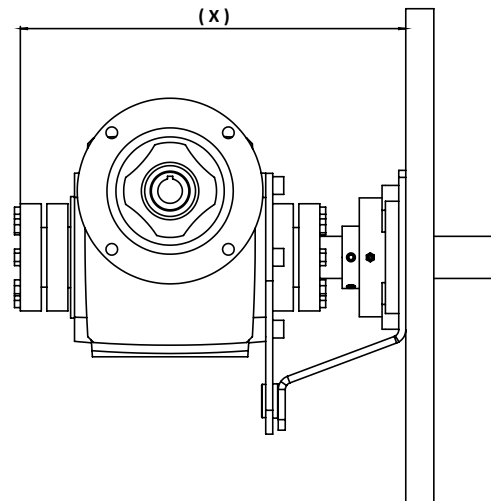

KSS Series: RIGHT ANGLE — Solid Shaft / Hollow Output

KSS Series: RIGHT ANGLE — Solid Shaft/Hollow Output

“A” Hollow Bore Output with “G” Pilot Circle Diameter (PCD) Tapped Holes

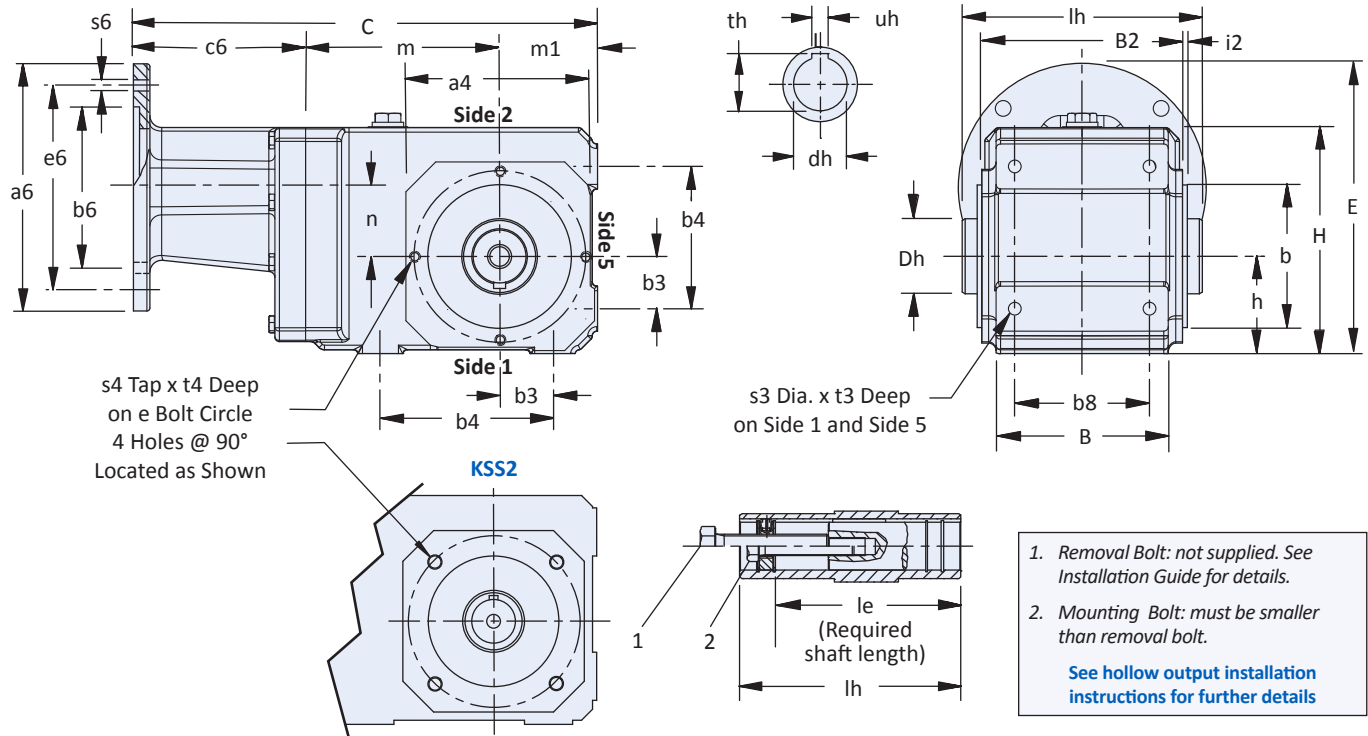

Table 1 KSS Series – “A” Hollow Output with “G” Pilot Circle Diameter (PCD) Tapped Holes – Dimensions (in)

Base Module	a4	b	B2	b4	b7	b8	e	H	h	i2	lh	m1	s3	s4	t3	t4
KSS1	4.53	2.95	4.17	3.54	2.95	2.76	3.54	4.96	2.36	0.12	4.72	2.36	M8x1.25	M8x1.25	0.51	0.51
KSS2	4.57	3.74	5.28	4.53	3.74	3.54	4.53	5.94	2.56	0.12	5.83	2.56	M10x1.50	M8x1.25	0.63	0.51
KSS3	5.20	3.74	5.75	5.12	4.13	4.13	4.53	6.56	2.95	0.12	6.30	2.95	M10x1.50	M8x1.25	0.63	0.55
KSS4	5.99	4.33	6.81	6.10	5.00	4.72	5.12	7.89	3.54	0.14	7.40	3.54	M12x1.75	M10x1.5	0.75	0.63

Table 2 KSS Series – “AG” Style Motor Adapter Dimensions (in)

Base Module	NEMA C-Face	a6	B	b3	b6	C	c6	E	e6	m	n	s6	Wt. lbs
KSS102AG_MS1R050	56C	6.50	3.54	1.18	4.500	10.55	3.81	7.03	5.87	4.37	1.42	0.41	29
KSS202AG_MS2R050	56C	6.50	4.41	1.38	4.500	12.20	4.53	7.62	5.87	5.12	1.81	0.41	40
KSS202AG_MS2R140	143/145TC	6.50	4.41	1.38	4.500	12.20	4.53	7.62	5.87	5.12	1.81	0.41	40
KSS203AG_MS2R050	56C	6.50	4.53	1.54	4.500	13.07	3.31	6.64	5.87	7.20	0.83	0.41	53
KSS302AG_MS3R050	56C	6.50			4.500	13.23	4.37	8.29	5.87	5.91	2.09	0.41	55
KSS302AG_MS3R140	143/145TC	6.50	5.51	1.38	4.500	13.23	4.37	8.29	5.87	5.91	2.09	0.41	55
KSS302AG_MS3R180	182/184TC	9.00			8.500	14.57	6.59	9.52	7.25	5.02	2.07	0.55	67
KSS303AG_MS3R050	56C	6.50	5.51	1.38	4.500	15.22	4.00	6.83	5.87	8.27	0.63	0.41	55
KSS303AG_MS3R140	143/145TC	6.50	5.51	1.38	4.500	15.22	4.00	6.83	5.87	8.27	0.63	0.41	55
KSS402AG_MS4R050	56C	6.50			4.500	14.76	4.53	9.66	5.87			0.41	84
KSS402AG_MS4R140	143/145TC	6.50	5.71	1.97	4.500	14.76	4.53	9.66	5.87	6.69	2.36	0.41	84
KSS402AG_MS4R180	182/184TC	9.00			8.500	15.79	5.55	10.91	7.25			0.55	89
KSS403AG_MS4R050	56C	6.50	5.71	1.97	4.500	16.46	3.86	8.39	5.87	9.06	0.98	0.41	94
KSS403AG_MS4R140	143/145TC	6.50	5.71	1.97	4.500	16.46	3.86	8.39	5.87	9.06	0.98	0.41	94

Table 3 “A” Hollow Bore Output — Standard Sizes (see page 62 for other available output options)

Base Module	Inches					
	Dh	dh	le	th	uh	Removal Bolt 1
KSS1	1.57	1	3.86	1.11	1/4	1/2 – 13
KSS2	1.97	1-1/4	4.78	1.37	1/4	1/2 – 13
KSS3	1.97	1-3/8	4.92	1.52	5/16	5/8 – 11
KSS4	2.17	1-1/2	6.18	1.67	3/8	3/4 – 10

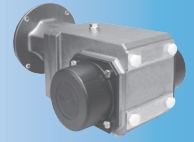

Dimensional Data

IP69K/STAINLESS STEEL

"A" Hollow Bore Output with "GD" Torque Arm Bracket

Refer to page 72 for all other dimensions

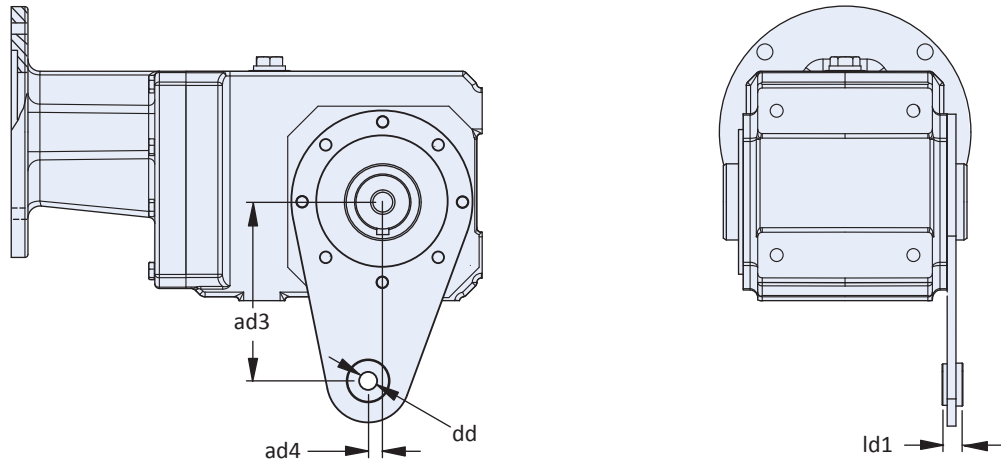

Table 4 "GD" Torque Arm

Base Module	Kit Number	mm			
		ad3	ad4	dd	ld1
KSS1	CS213227	130	10	13	15
KSS2	CS129573	130	10	13	15
KSS3	CS129573	130	10	13	15
KSS4	CS139679	130	10	13	15

"A" Hollow Bore Output with torque arm stabilizer bracket

KIT PART NUMBERS

CS137561 (205/206 A-Quill Bearing)

CS137562 (207/208 A-Quill Bearing)

Required Shaft Lengths

Hollow A Quill Length

Unit/Flange Bearing	205/206	207/208
KSS1	6.63	-
KSS2	7.24	7.33
KSS3	7.69	7.78
KSS4	8.93	9.02

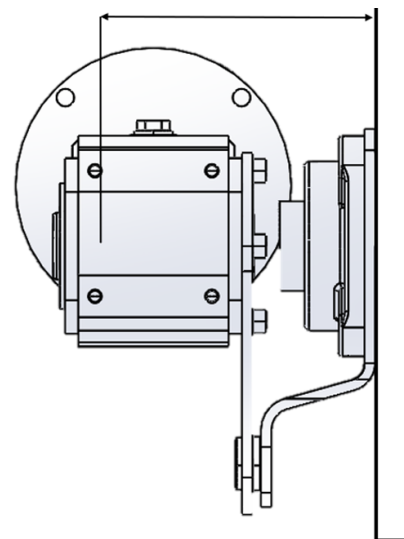

KSS Series: RIGHT ANGLE — Solid Shaft / Hollow Output

KSS Series: RIGHT ANGLE — Solid Shaft/Hollow Output

“A” Hollow Bore Output with “F” Round Flange Housing

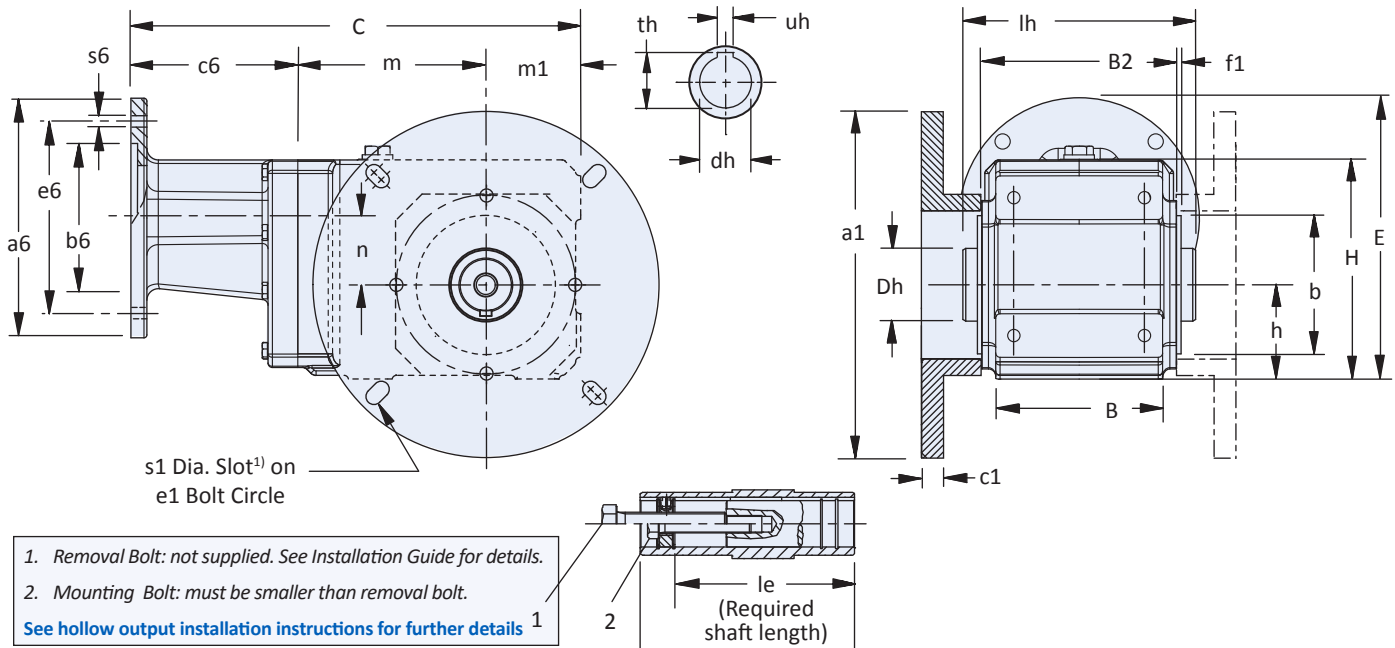

Table 1 KSS Series – “A” Hollow Output with “F” Round Flange Housing – Dimensions (in)

Base Module	a1	b	B2	c1	c2	e1		f1	H	h	lh	m1	s1 ¹⁾
						Min.	Max. ¹⁾						
KSS1	6.75	2.95	4.17	0.55	1.50	5.87	—	0.12	4.96	2.36	4.72	2.36	0.33
KSS2	8.74	3.74	5.28	0.55	1.50	7.48	8.00	0.12	5.94	2.56	5.28	2.56	0.41
KSS3	8.74	3.74	5.75	0.55	1.50	7.48	8.00	0.12	6.56	2.95	6.30	2.95	0.41
KSS4	9.84	4.33	6.81	0.55	1.50	8.46	—	0.14	7.89	3.54	7.40	3.54	0.53

1) KSS1 & KSS4 mounting bolt hole is not a slot.

Table 2 KSS Series – “AF” Style Motor Adapter Dimensions (in)

Base Module	NEMA C-Face	a6	B	b6	C	c6	E	e6	m	n	s6	Wt. lbs
KSS102AF_MS1R050	56C	6.50	3.54	4.500	10.09	3.81	7.03	5.87	4.38	1.42	0.41	29
KSS202AF_MS2R050	56C	6.50	4.41	4.500	12.20	4.53	7.62	5.87	5.11	1.81	0.41	40
KSS202AF_MS2R140	143/145TC	6.50	4.41	4.500	12.20	4.53	7.62	5.87	5.11	1.81	0.41	40
KSS203AF_MS2R050	56C	6.50	4.53	4.500	13.07	3.31	6.64	5.87	7.20	1.81	0.41	53
KSS302AF_MS3R050	56C	6.50	4.500	4.500	13.23	4.37	8.29	5.87	5.91	2.09	0.41	55
KSS302AF_MS3R140	143/145TC	6.50	5.51	4.500	13.23	4.37	8.29	5.87	5.91	2.09	0.41	55
KSS302AF_MS3R180	182/184TC	9.00	8.500	4.500	14.57	6.59	9.52	7.25	5.03	2.07	0.55	67
KSS303AF_MS3R050	56C	6.50	5.51	4.500	15.22	4.00	6.83	5.87	8.27	0.63	0.41	55
KSS303AF_MS3R140	143/145TC	6.50	5.51	4.500	15.22	4.00	6.83	5.87	8.27	0.63	0.41	55
KSS402AF_MS4R050	56C	6.50	4.500	4.500	14.76	4.53	9.96	5.87	6.69	2.36	0.41	84
KSS402AF_MS4R140	143/145TC	6.50	5.71	4.500	14.76	4.53	9.96	5.87	6.69	2.36	0.41	84
KSS402AF_MS4R180	182/184TC	9.00	8.500	4.500	15.79	5.55	10.91	7.25	5.03	2.07	0.55	89
KSS403AF_MS4R050	56C	6.50	5.71	4.500	16.46	3.86	8.39	5.87	9.06	0.98	0.41	94
KSS403AF_MS4R140	143/145TC	6.50	5.71	4.500	16.46	3.86	8.39	5.87	9.06	0.98	0.41	94

Table 3 “A” Hollow Bore Output — Standard Sizes (see page 62 for other available output options)

Base Module	Inches						Removal Bolt 1
	Dh	dh	le	th	uh		
KSS1	1.57	1	3.86	1.11	1/4		1/2 – 13
KSS2	1.97	1-1/4	4.78	1.37	1/4		1/2 – 13
KSS3	1.97	1-3/8	4.92	1.52	5/16		5/8 – 11
KSS4	2.17	1-1/2	6.18	1.67	3/8		3/4 – 10

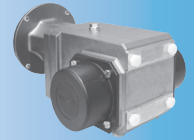

"V" Solid Shaft Output with "F" Round Flange Housing

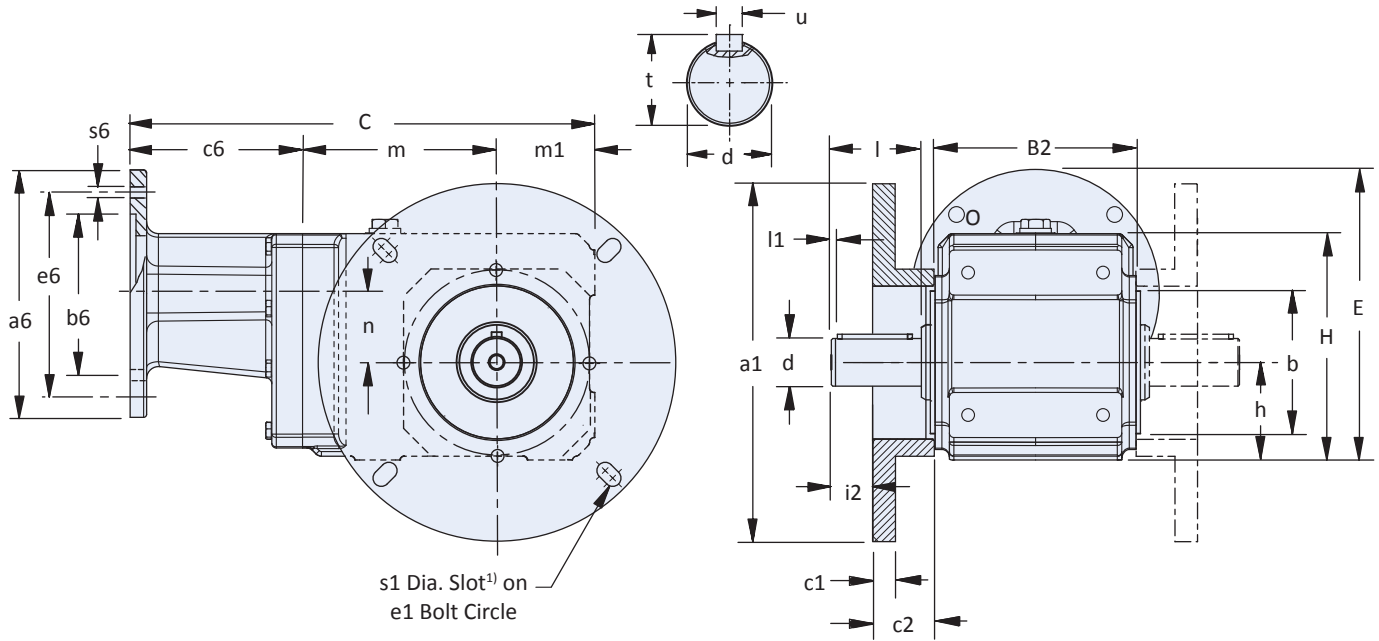

Table 1 KSS Series – "V" Solid Shaft Output with "F" Round Flange Housing Dimensions (in)

Base Module	a1	b	B2	c1	c2	e1		H	h	i2	l	l1	m1	s1 ¹⁾
						Min.	Max. ¹⁾							
KSS1	6.75	2.95	4.17	0.55	1.50	5.87	—	4.96	2.36	0.94	1.97	0.16	2.36	0.33
KSS2	8.74	3.74	5.28	0.55	1.50	7.48	8.00	5.94	2.56	1.21	2.36	0.16	2.56	0.41
KSS3	8.74	3.74	5.75	0.55	1.50	7.48	8.00	6.56	2.95	1.21	2.36	0.16	2.95	0.41
KSS4	9.84	4.33	6.81	0.55	1.50	8.46	—	7.89	3.54	1.63	2.76	0.16	3.54	0.53

1) KSS1 & KSS4 mounting bolt hole is not a slot.

Table 2 KSS Series – "VF" Style Motor Adapter Dimensions (in)

Base Module	NEMA C-Face	a6	b6	C	c6	E	e6	m	n	s6	Wt. lbs
KSS102VF_MS1R050	56C	6.50	4.500	10.55	3.81	7.03	5.87	4.38	1.42	0.41	29
KSS202VF_MS2R050	56C	6.50	4.500	12.20	4.53	7.62	5.87	5.11	1.81	0.41	40
KSS202VF_MS2R140	143/145TC	6.50	4.500	12.20	4.53	7.62	5.87	5.11	1.81	0.41	40
KSS203VF_MS2R050	56C	6.50	4.500	13.07	3.31	6.64	5.87	7.20	0.83	0.41	53
KSS302VF_MS3R050	56C	6.50	4.500	13.23	4.37	8.29	5.87	5.91	2.09	0.41	55
KSS302VF_MS3R140	143/145TC	6.50	4.500	13.23	4.37	8.29	5.87	5.91	2.09	0.41	55
KSS302VF_MS3R180	182/184TC	9.00	8.500	14.57	6.59	9.52	7.25	5.03	2.07	0.55	67
KSS303VF_MS3R050	56C	6.50	4.500	15.22	4.00	6.83	5.87	8.27	0.63	0.41	55
KSS303VF_MS3R140	143/145TC	6.50	4.500	15.22	4.00	6.83	5.87	8.27	0.63	0.41	55
KSS402VF_MS4R050	56C	6.50	4.500	14.76	4.53	9.96	5.87	6.69	2.36	0.41	84
KSS402VF_MS4R140	143/145TC	6.50	4.500	14.76	4.53	9.96	5.87	6.69	2.36	0.41	84
KSS402VF_MS4R180	182/184TC	9.00	8.500	15.79	5.55	10.91	7.25	5.03	2.07	0.55	89
KSS403VF_MS4R050	56C	6.50	4.500	16.46	3.86	8.39	5.87	9.06	0.98	0.41	94
KSS403VF_MS4R140	143/145TC	6.50	4.500	16.46	3.86	8.39	5.87	9.06	0.98	0.41	94

Table 3 "V" Solid Shaft Output — Standard Sizes

Base Module	Inches		
	d	t	u— Key
KSS1	1	1.11	1/4 x 1/4 x 1-9/16
KSS2	1-1/4	1.36	1/4 x 1/4 x 1-15/16
KSS3	1-1/4	1.36	1/4 x 1/4 x 1-15/16
KSS4	1-3/8	1.51	5/16 x 5/16 x 2-5/16

KSS Series: RIGHT ANGLE — Solid Shaft / Hollow Output

KSS Series: RIGHT ANGLE — Solid Shaft/Hollow Output

“V” Solid Shaft Output with “G” Pilot Circle Diameter (PCD) Tapped Holes

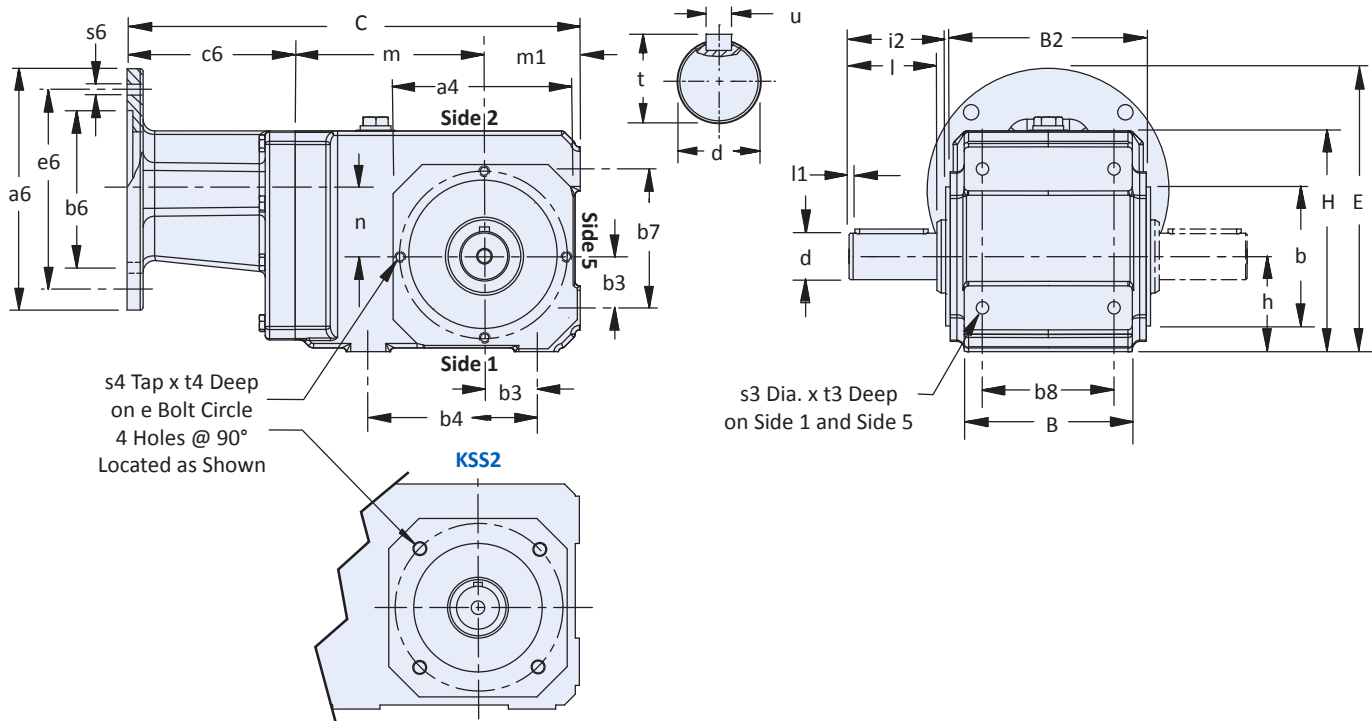

Table 1 KSS Series – “V” Solid Shaft Output with “G” Pilot Circle Diameter (PCD) Tapped Holes – Dimensions (in)

Base Module	a4	b	B2	b3	b4	b7	b8	e	H	h	i2	l	l1	m1	s3	s4	t3	t4
KSS1	4.53	2.95	4.17	1.18	3.54	2.95	2.76	3.54	4.96	2.36	2.32	1.97	0.16	2.36	M8x1.25	M8x1.25	0.51	0.51
KSS2	4.57	3.74	5.28	1.38	4.53	3.74	3.54	4.53	5.94	2.56	2.60	2.36	0.16	2.56	M10x1.50	M8x1.25	0.63	0.51
KSS3	5.20	3.74	5.75	1.38	5.12	4.13	4.13	4.53	6.56	2.95	2.60	2.36	0.16	2.95	M10x1.50	M8x1.25	0.63	0.55
KSS4	5.99	4.33	6.81	1.97	6.10	5.00	4.72	5.12	7.89	3.54	3.39	2.76	0.16	3.54	M12x1.75	M10x1.5	0.75	0.63

Table 2 KSS Series – “VG” Style Motor Adapter Dimensions (in)

Base Module	NEMA C-Face	a6	B	b6	C	c6	E	e6	m	n	s6	Wt. lbs
KSS102VG_MS1R050	56C	6.50	3.54	4.500	10.55	3.81	7.03	5.87	4.38	1.42	0.41	29
KSS202VG_MS2R050	56C	6.50	4.41	4.500	12.20	4.53	7.62	5.87	5.11	1.81	0.41	40
KSS202VG_MS2R140	143/145TC	6.50	4.53	4.500	13.07	3.31	6.64	5.87	7.20	0.83	0.41	53
KSS203VG_MS2R050	56C	6.50	4.53	4.500	13.23	4.37	8.29	5.87	5.91	2.09	0.41	55
KSS302VG_MS3R050	56C	6.50	5.51	4.500	13.23	4.37	8.29	5.87	5.91	2.09	0.41	55
KSS302VG_MS3R140	143/145TC	6.50	5.51	4.500	13.23	4.37	8.29	5.87	5.91	2.09	0.41	55
KSS302VG_MS3R180	182/184TC	9.00	8.500	14.57	6.59	9.52	7.25	5.03	2.07	0.55	0.55	67
KSS303VG_MS3R050	56C	6.50	5.51	4.500	15.22	4.00	6.83	5.87	8.27	0.63	0.41	55
KSS303VG_MS3R140	143/145TC	6.50	5.51	4.500	15.22	4.00	6.83	5.87	8.27	0.63	0.41	55
KSS402VG_MS4R050	56C	6.50	5.71	4.500	14.76	4.53	9.96	5.87			0.41	84
KSS402VG_MS4R140	143/145TC	6.50	5.71	4.500	14.76	4.53	9.96	5.87	6.69	2.36	0.41	84
KSS402VG_MS4R180	182/184TC	9.00	8.500	15.79	5.55	10.91	7.25				0.55	89
KSS403VG_MS4R050	56C	6.50	5.71	4.500	16.46	3.86	8.39	5.87	9.06	0.98	0.41	94
KSS403VG_MS4R140	143/145TC	6.50	5.71	4.500	16.46	3.86	8.39	5.87	9.06	0.98	0.41	94

Table 3 “V” Solid Shaft Output — Standard Sizes

Base Module	Inches		
	d	t	u— Key
KSS1	1	1.11	1/4 x 1/4 x 1-9/16
KSS2	1-1/4	1.36	1/4 x 1/4 x 1-15/16
KSS3	1-1/4	1.36	1/4 x 1/4 x 1-15/16
KSS4	1-3/8	1.51	5/16 x 5/16 x 2-5/16

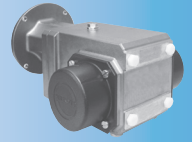

“V” Solid Shaft Output with “NG” Foot Mount Housing

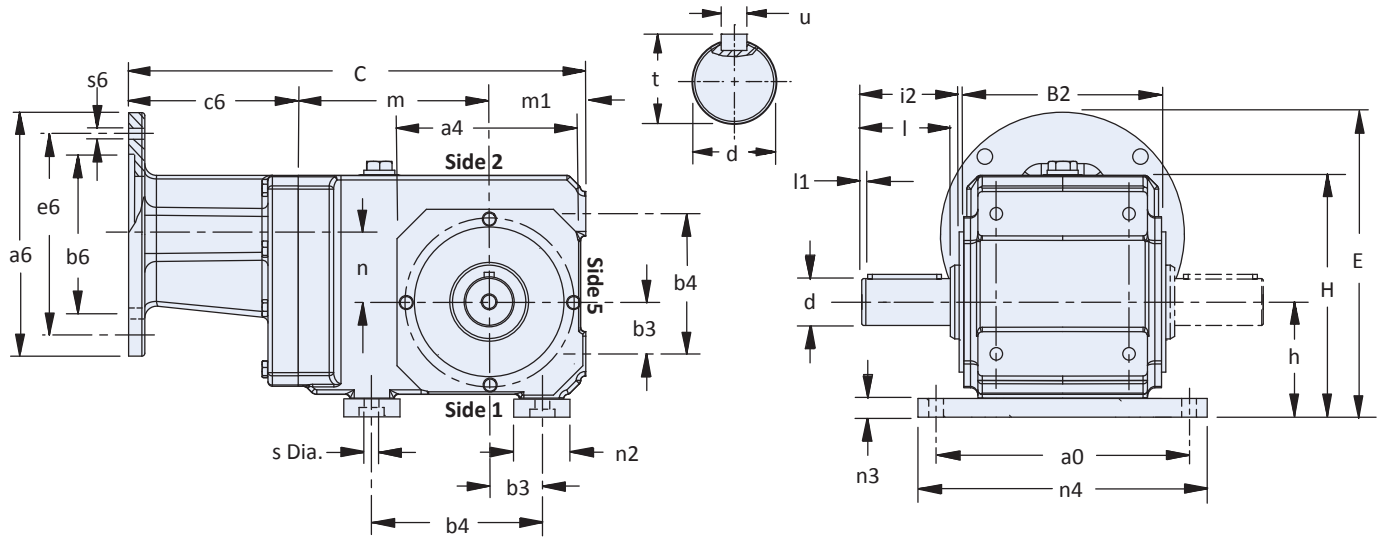

Table 1 KSS Series – “V” Solid Shaft Output with “NG” Foot Mount – Dimensions (in)

Base Module	a0	a4	B2	b3	b4	b7	e	H	h	i2	l	l1	m1	n2	n3	n4	s
KSS1	4.53	4.53	4.17	1.18	3.54	2.95	3.54	5.46	2.36	2.32	1.97	0.16	2.36	1.50	0.50	5.51	0.35
KSS2	6.73	4.57	5.28	1.38	4.53	3.74	4.53	6.44	3.07	2.60	2.36	0.16	2.56	1.50	0.50	7.72	0.39
KSS3	6.73	5.20	5.75	1.38	5.12	4.13	4.53	7.06	3.44	2.60	2.36	0.16	2.95	1.50	0.50	7.72	0.39
KSS4	7.87	5.99	6.81	1.97	6.10	5.00	5.12	8.64	3.54	3.39	2.76	0.16	3.54	1.50	0.75	9.06	0.55

Table 2 KSS Series – “VNG” Style Motor Adapter Dimensions (in)

Base Module	NEMA C-Face	a4	a6	b6	C	c6	E	e6	m	n	s6	Wt. lbs
KSS102VNG_MS1R050	56C	4.53	6.50	4.500	10.55	3.81	7.53	5.87	4.38	1.42	0.41	29
KSS202VNG_MS2R050	56C	4.57	6.50	4.500	12.20	4.53	8.12	5.87	5.11	1.81	0.41	40
KSS202VNG_MS2R140	143/145TC											
KSS203VNG_MS2R050	56C	4.57	6.50	4.500	13.07	3.31	7.14	5.87	7.20	0.83	0.41	53
KSS302VNG_MS3R050	56C		6.50	4.500	13.23	4.37	8.79	5.87	5.91	2.09	0.41	55
KSS302VNG_MS3R140	143/145TC	5.20	6.50	4.500	13.23	4.37	8.79	5.87	5.91	2.09	0.41	55
KSS302VNG_MS3R180	182/184TC		9.00	8.500	14.57	6.59	10.02	7.25	5.03	2.07	0.55	67
KSS303VNG_MS3R050	56C											
KSS303VNG_MS3R140	143/145TC	5.20	6.50	4.500	15.22	4.00	7.33	5.87	8.27	0.63	0.41	55
KSS402VNG_MS4R050	56C		6.50	4.500	14.76	4.53	10.41	5.87			0.41	84
KSS402VNG_MS4R140	143/145TC	5.99	6.50	4.500	14.76	4.53	10.41	5.87	6.69	2.36	0.41	84
KSS402VNG_MS4R180	182/184TC		9.00	8.500	15.79	5.55	11.66	7.25			0.55	89
KSS403VNG_MS4R050	56C											
KSS403VNG_MS4R140	143/145TC	5.99	6.50	4.500	16.46	3.86	9.14	5.87	9.06	0.98	0.41	94

Table 3 “V” Solid Shaft Output — Standard Sizes

Base Module	Inches		
	d	t	u— Key
KSS1	1	1.11	1/4 x 1/4 x 1-9/16
KSS2	1-1/4	1.36	1/4 x 1/4 x 1-15/16
KSS3	1-1/4	1.36	1/4 x 1/4 x 1-15/16
KSS4	1-3/8	1.51	5/16 x 5/16 x 2-5/16

KSS Series: RIGHT ANGLE — Solid Shaft / Hollow Output

K/KL Series: RIGHT ANGLE — Solid Shaft/Hollow Output

K/KL Series Features

- Input rating up to: 2 HP (KL); 105 HP (K)
- Ratio options: 4:1 – 32:1 (KL); 4:1 – 373.7:1 (K)
- Output Torque capability up to: 443 lb-in (KL); 92,250 lb-in (K)
- NEMA input capabilities: 56C (KL); 56C, 143/145TC, 182/184TC, 213/215TC, 254/256TC, 284/286TC, 324/326TC, 364/365TC (K)
- Output bore diameters: 3/4" (KL); 1" – 4" (K)
- Housing style options: flange, feet, or tapped holes (K/KL); torque arm bracket (K and KL2 only)

The K/KL Series offer higher input-to-output efficiencies than conventional worm gear drives, reducing costs with smaller sized gear drives and motors, and optimum energy savings.

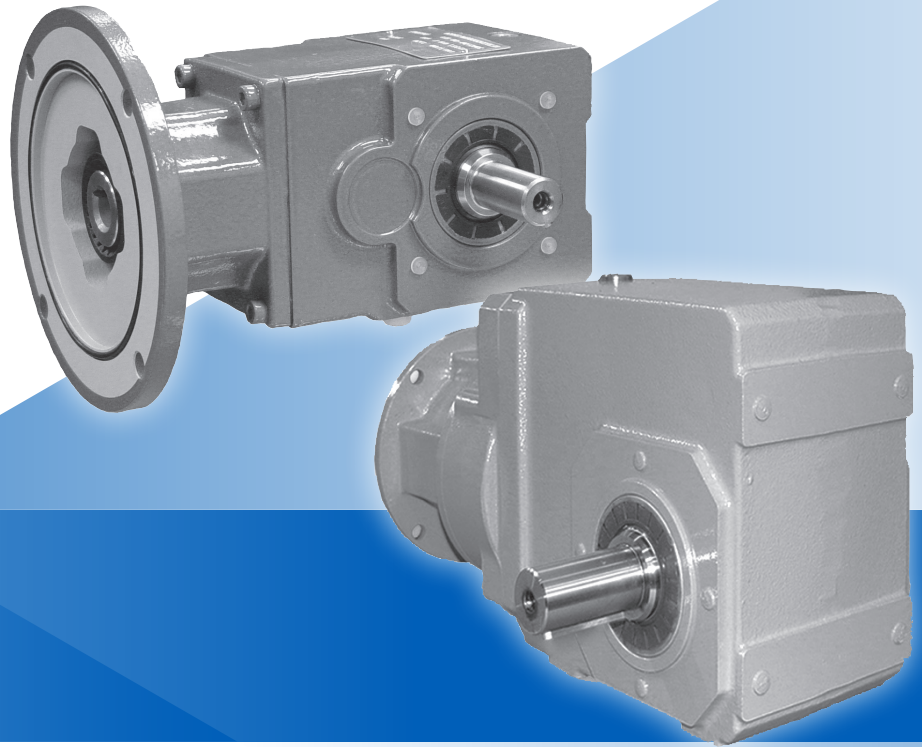

**SHIPS in
1 DAY!**

**NO EXPEDITE FEE FOR 24
HOUR SERVICE**

K/KL Series Benefits

- No maintenance - totally enclosed with no breather to allow contaminants in or oil out
- Lubricated for life with Mobil oil
- Simple motor mounting and removal with Bowex coupling
- Energy savings - up to 97% efficiency
- Easy installation and removal with our patented bushing system and any horizontal mounting position
- Reliability guaranteed with 3 year warranty
- Adaptability - mounting gear reducer from either machine side means less storeroom stock
- Durability - IP69K Certified to prevent water and dust ingress
- Assembled in USA
- Combine units to achieve slower speeds to meet your application needs (K Series)

K/KL Food & Corrosion Resistant Options

"F" Option for Food Duty Applications

- Totally enclosed unit — no breathers, maintenance free, lubricated for life
- Mobil SHC CIBUS 220 food grade oil
- Anti-microbial clear coat
- 316 stainless steel epoxy coating
- Stainless steel shaft, hollow bore or double bushing output
- USDA Accepted Equipment

"B" Option for Corrosion Resistant Applications

- Totally enclosed unit — no breathers, maintenance free, lubricated for life
- Mobil 600XP220 mineral oil
- 316 stainless steel epoxy coating
- Stainless steel shaft, hollow bore or double bushing output

Other K/KL Design Options Available:

- Plated or stainless steel hardware
- IP69K certified to prevent water and dust ingress (see page 6 for full details)



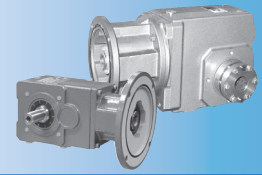

Overview

K/KL Ordering Options At-a-Glance

K and KL Series are available in a wide range of user-selected design options that tailor the speed reducer to your motor and exact application requirements. Use the appropriate order codes below to build a part number for the complete assembly.

Part Number Examples:

	1	2	3	4	5	6	7	8	9	0	I**
Standard duty KL Series	KL	2	0	2	A	F	0040	ML2R/	050		
Standard duty K Series	K	2	0	2	A	F	0040	MR140/	050		EL1256
Food duty K Series	K	2	0	2	A	F	0040	MR140/	050	F	EL1256

	Design Option	Part Number Code	Description
1	Series	K KL	Modular right angle helical/bevel Compact right angle helical/bevel
2	Size	2	K Series: 10 sizes of speed reducers (1 thru 10); KL Series: size 2 only
3	Generation	0	0 for sizes K1 thru K4; 1 for sizes K5 thru K10; 0 for KL
4	# of Stages	2	Two, three or four stage (determined by ratio)
5	Output*	A	Hollow bore output (K Series, see page 82); KL Series \varnothing 20 mm*
		P	Solid shaft output with key (KL only), \varnothing 0.75" or 20 mm (specify side 3, 4 or double sided)*
		V	Solid shaft output with key (K only, see page 82), (specify side 3, 4, or double sided)
		W	K Series: Single or double wobble-free bushing (specify side 3 or 4 for single bushing) KL Series: Double wobble-free bushing (\varnothing 0.75")
6	Housing	F	Output flange mount (specify side 3 or 4) Note: square flange for KL; round flange for K
		G	Pilot Circle Diameter (PCD) tapped holes
		GD	Tear drop bracket - KL2 series only Torque arm bracket mounting - K series only, specify bracket placement - side 1 or 5, also on K1 side 2
		NG	Foot mounting (specify side 1 or 5; or side 2 on K1 only)
7	Ratio	0040	Ratios range from 4:1 to 373.7:1 (K Series) or 4:1 to 32:1 (KL Series) Refer to Selection Data tables. Note: if a slower speed is required, units can be combined to achieve the necessary ratio for low speed applications. Contact STÖBER Drives Inc.
8	Motor Adapter	MR140 thru MR350 ML2R	K Series: Round motor adapter sizes (refer to Selection Data tables) KL Series: Round motor adapter
		050 140 180 210 250 280 320 360	56C 143/145TC 182/184TC 213/215TC 254/256TC 284/286TC 324/326TC 364/365TC
9	NEMA Frame Size (refer to Selection Data tables)		
0	Food & Corrosion Resistant Option	F B	Food duty service Corrosion resistant duty service
I	Mounting Position** <i>Refer to page 83 illustrations</i>	EL1 EL2 EL3 EL4 EL5 EL6 EL1256	K Series: Mounting position codes required for 3 year warranty; KL Series: Mounting position is unrestricted, no code required

K/KL Series: RIGHT ANGLE — Solid Shaft / Hollow Output

* Standard KL Series Hollow Bore and Solid Shaft options are carbon steel; contact factory for stainless steel option. Double solid shaft is only available in metric.
** Mounting position is added to "notes" section of order.

K/KL Series: RIGHT ANGLE — Solid Shaft/Hollow Output

KL Output and Housing Configurations

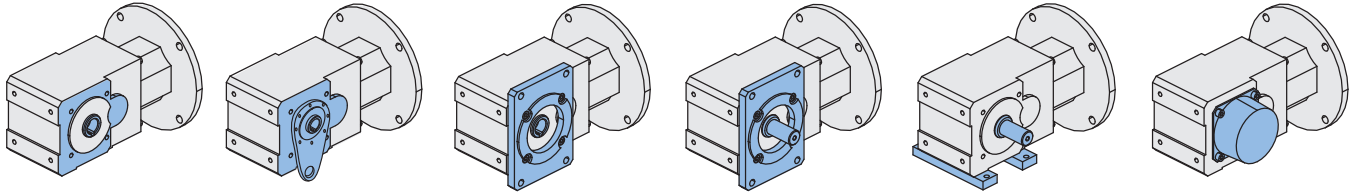

See Page	page <?>	page 105	page <?>	page 104	page 104	page 105
Output	A Hollow Bore	A Hollow Bore	A Hollow Bore	P Solid Shaft	P Solid Shaft	W Double Bushing
Housing	G Tapped Holes	GD Torque Arm Bracket	F Flange Mount	F Flange Mount	NG Foot Mount	G Tapped Holes

KL Series Orientation

Unrestricted mounting position

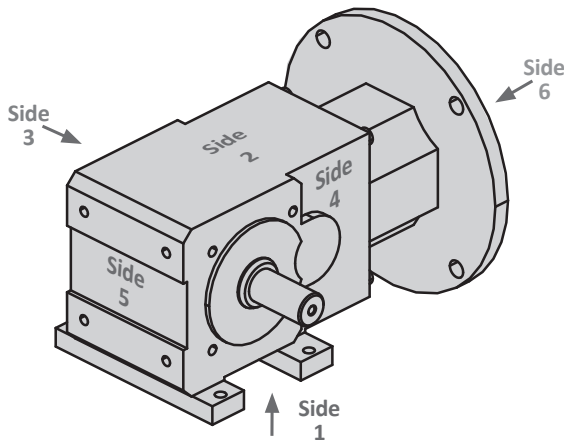

KL Series Direction of Rotation

Output available on side 3, 4 or both. Note: With a double output, the shaft rotation of Side 3 will be the OPPOSITE direction of Side 4 when viewed from Side 5.

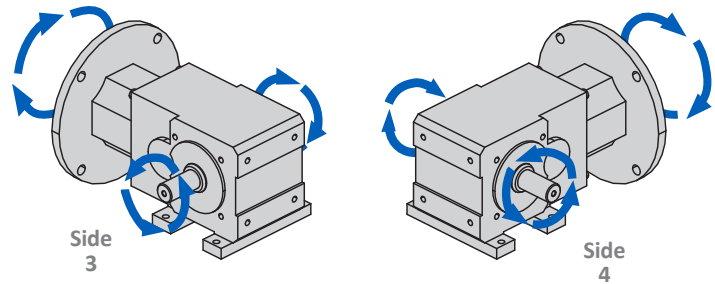

KL Series Output Options

BLUE: standard output diameters in stock

BLACK: optional diameters in stock

Other options are available upon request. Please contact STÖBER to learn about other options and their deliveries.

KL Series			KL2		
"P" Solid Shaft*	Carbon Steel	Inches	3/4	Metric	20
	Stainless Steel	Inches	3/4	Metric	20
"A" Hollow Bore	Carbon Steel	Inches	3/4	Metric	20
	Stainless Steel	Inches	3/4		—
"WFB" Wobble Free Double Bushing	Stainless Steel	Inches	3/4		—

*Double shaft configuration available in metric only

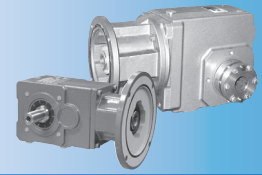

Overview

K Output and Housing Configurations

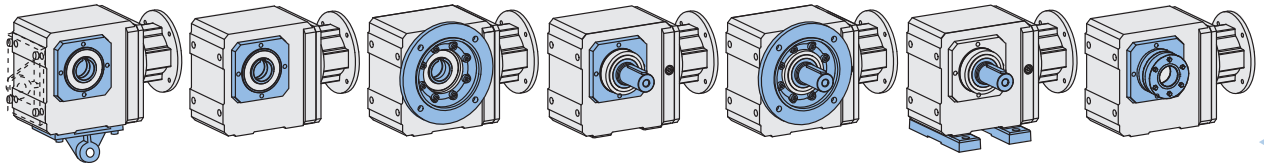

See Page	page 106	page 108	page 110	page 112	page 114	page 116	page 118 & page 120
Output	A Hollow Bore	A Hollow Bore	A Hollow Bore	V Solid Shaft	V Solid Shaft	V Solid Shaft	W Wobble Free Bushing Single or Double
Housing	GD Torque Arm Bracket	G Tapped Holes	F Flange Mount	G Tapped Holes	F Flange Mount	NG Foot Mount	G Tapped Holes

Availability*

Standard Duty	K1-K10	K1-K10	K1-K10	K1-K10	K1-K10	K1-K10	K1-K8
Food & Corrosion Resistant Duty**	K1-K9	K1-K9	K1-K9	K1-K9	K1-K9	K1-K9	K1-K8

* See Output Options Chart page 82 for standard and optional solid shaft, hollow bore and wobble free bushing options.

** On K5 and above, food and corrosion resistant duty availability is dependent on mounting position, ratio, input speed and ambient temperature. Breathers may be required. Please contact the factory for support.

K Series Orientation

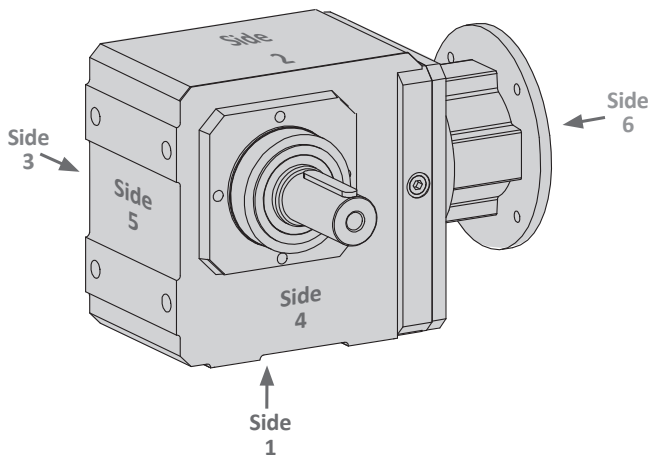

K Series Direction of Rotation

Output available on side 3, 4 or both. Note: With a double output, the shaft rotation of Side 3 will be the OPPOSITE direction of Side 4 when viewed from Side 5.

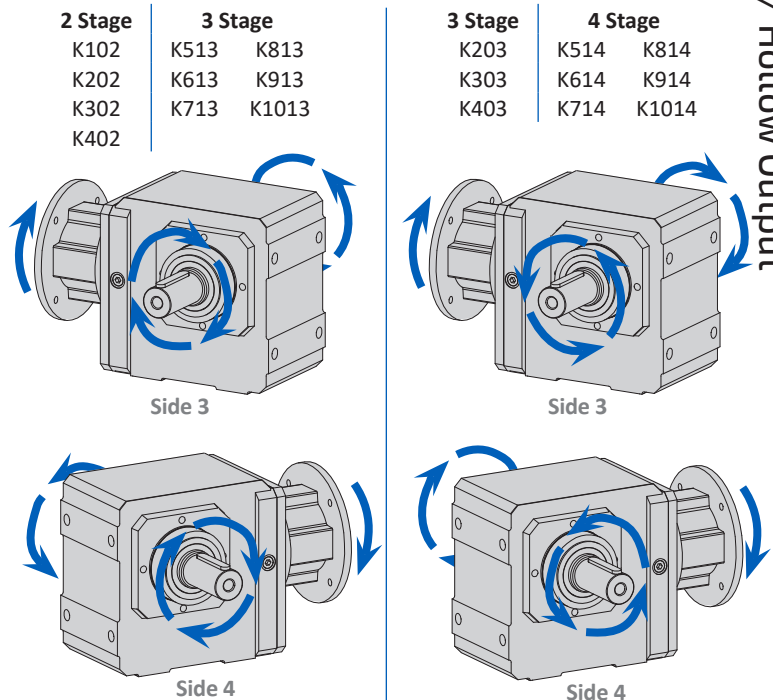

K/KL Series: RIGHT ANGLE — Solid Shaft / Hollow Output

K/KL Series: RIGHT ANGLE — Solid Shaft/Hollow Output

K Series Output Options

BLUE: standard output diameters in stock

BLACK: optional diameters in stock

Other options are available upon request. Please contact STÖBER to learn about other options and their deliveries.

K Series			KL2	K1	K2	K3	K4	K5	K6	K7	K8	K9	K10
"V" Solid Shaft	Carbon Steel	Inches	3/4*	1	1-1/4	1-1/4	1-3/8	1-3/4	1-3/4	2-3/8	2-7/8	3-5/8	4-3/8
		Metric	20	25	30	30	40	45	50	60	70	90	110
	Stainless Steel	Inches	3/4	1	1-1/4	1-1/4	1-3/8	1-3/4	1-3/4	2-3/8	2-7/8	3-5/8	—
		Metric	20	25	—	—	—	45	—	—	—	—	—
"A" Hollow Bore	Carbon Steel	Inches	3/4	1	1-3/16	1-3/8	1-1/2	2	2	2-3/8	2-3/4	3-1/4	4
		Metric	20	25	30	35	40	50	50	60	70	90	—
	Stainless Steel	Inches	3/4	1	1-1/4	1-3/8	1-1/2	2	2	2-3/8	2-3/4	2-15/16 3 3-7/16	—
		Metric	—	25	30	35	40	50	—	60	—	75	—
"W" Wobble Free Bushing (single and Double Bushings)	Stainless Steel*	Inches	3/4	1	1 1-3/16 1-1/4	1* 1-3/16 1-1/4 1-3/8 1-7/16 1-1/2	1-1/4 1-7/16 1-1/2	1-7/16 1-1/2 1-15/16 2 2	1-7/16 1-1/2 1-15/16 2 2-3/16	1-15/16 2 2-3/8	2-3/16 2-3/8 2-7/16 2-3/4	—	—
		Metric	—	—	—	—	40	40	—	—	—	—	—

*Also available in carbon steel

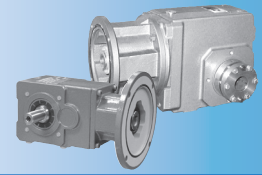

Overview

K Mounting Position Options

When ordering any K unit, the mounting position must be specified. Use one of the mounting position order codes illustrated below that corresponds to the intended application.

Note: All illustrations below are shown with a solid shaft output on side 4. K units can have a solid shaft, hollow or single bushing output on either Side 3 or Side 4. **The desired output side must be specified when ordering.**

Standard Duty

All STÖBER standard duty units are filled with the correct amount of lubrication before shipping. In order to provide the proper lubrication quantity, the mounting position must be specified at the time the unit is ordered.

DO NOT mount standard duty reducers in a position other than the mounting position specified on the order!

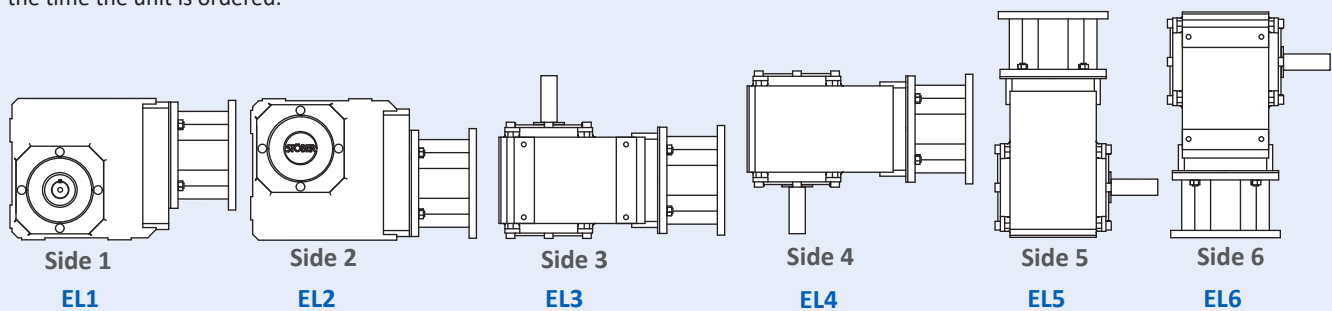

Food & Corrosion Resistant Duty

Food and Corrosion Resistant Duty units are equipped with specialized seals, higher oil level, and additional features compared to standard units. These added features enable all horizontal output positions (EL1, 2, 5 and 6) to be used interchangeably, subject to size and ratio. On K5 and above, food and corrosion resistant duty availability is dependent on mounting position, ratio, input speed and ambient temperature. Breathers may be required. Please contact the factory for support. Contact STÖBER for details.

DO NOT mount horizontal Food and Corrosion Resistant Duty reducers in a vertical position, or mount vertical position reducers other than specified on the order!

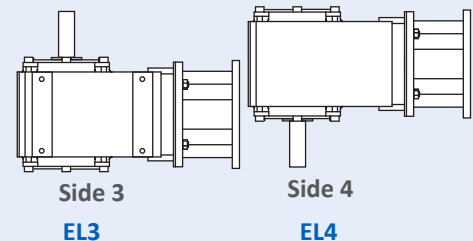
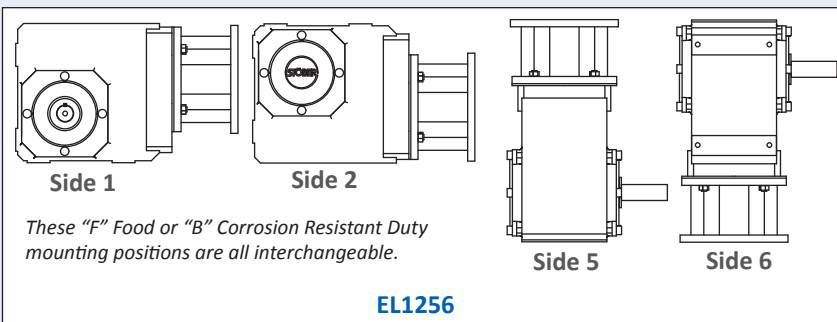

K/KL Series: RIGHT ANGLE — Solid Shaft / Hollow Output

Permissible Motor Tilting Torque

The permissible tilting torque of the motor attached to the gear unit is a result of the static and dynamic load "F" from the motor weight, mass acceleration, and vibration multiplied by the distance from the center of gravity "l_s" of the motor.

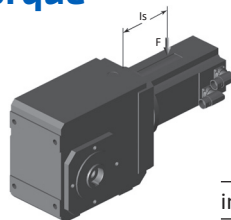

$$M_{1k} = F \times l_s \leq M_{1K}$$

M _{1K}	MR140	MR160	MR200	MR250	MR300	MR350
in.lbs	221	531	1106	2212	5310	10,620

K/KL Series: RIGHT ANGLE — Solid Shaft/Hollow Output

K Series Lubrication Maintenance

K102 thru K403 are supplied without breathers and are lubricated for life and maintenance free.

Breathers are provided on K513 thru K1014, located as shown*. STOBER recommends changing the lubrication in breather supplied units after 10,000 hours for normal operating conditions or every

5,000 hours for wet operating conditions.

**K513 and larger units with the Food & Corrosion Resistant option can exclude a breather. Contact STOBER for details.*

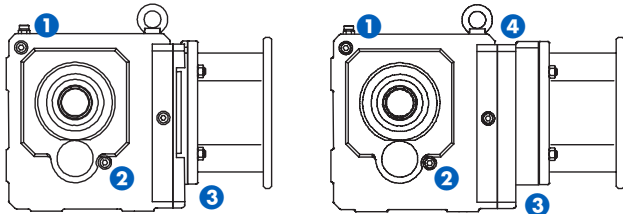

3 Stage Units
(K513 thru K1013)

4 Stage Units
(K514 thru K1014)

Drain Plug and Vent Location

Mounting Position	1	2 *	2a *	3	4
EL1	Vent			Drain	
EL2	Drain			Vent	
EL3		Vent	Drain		
EL4		Drain	Vent		
EL5	K513-K1013	Drain		Vent	
	K514-K1014	Drain			Vent
EL6	K513-K1013	Vent		Drain	
	K514-K1014	Vent			Drain

** Position 2a is on the opposite side of 2.*

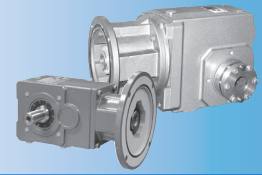

Overview

K/KL Series: RIGHT ANGLE — Solid Shaft / Hollow Output

K/KL Sizing/Selection:

1. Find the **RPM Output (Approximate)** nearest the application requirement. (If the exact Output RPM is required, divide the Input RPM [1750] by the value listed in the Exact Ratio column.)
- 2a. In the **Input HP** column, locate the rating that is greater than or equal to the required HP, or;
- 2b. If selection is based on Torque instead of HP, find an **Output Torque** that is equal to or greater than required.
3. Confirm that the **Overhung Load** is acceptable for the application.
4. Choose the appropriate **Base Module** and **Motor Adapter** part number code (see page 79 for complete ordering information). For K Series units, an optional input shaft, in place of the NEMA C-face motor adapter, is also available.

Selection Data

1750 RPM Input		Nominal Ratio	Overhung Load Output Shaft ¹⁾ (lbs)	Part Number Codes (in blue)		
Input HP	Output Torque (lb-in)			Base Module	Motor Adapter/ NEMA Motor	Compatible NEMA C-Frame ²⁾ with Designated Motor Adapter
435 RPM Output (Approximate)						
2.08*	291	4.000	225	KL202_0040	ML2R050	56C
3.92*	548	4.000	402	K102_0040	MR160/050	56C
					MR160/140	143/145TC
7.00*	979	4.000	483	K202_0040	MR160/050	56C
					MR160/140	143/145TC
					MR200/180	182/184TC
9.22*	1,289	4.000	563	K302_0040	MR160/050	56C
					MR160/140	143/145TC
9.22	1,289	4.000	901	K402_0040	MR160/050	56C
					MR160/140	143/145TC
12.26*	1,714	4.000	563	K302_0040	MR200/180	182/184TC
18.39*	2,572	4.000	901	K402_0040	MR200/180	182/184TC
					MR250/210	213/215TC
340 RPM Output (Approximate)						
5.89*	1,067	5.177	526	K202_0052	MR160/050	56C
					MR160/140	143/145TC
					MR200/180	182/184TC

1) Overhung Load is measured at the center of the shaft extension. Hollow output units are not intended to support overhung loads. If a load rating is required, use 50% of the published overhung load.

2) **Motor HP for TEFC NEMA C-Frame @ 1750 RPM**

Order Code	050	140	180	210	250	280	320	360
C-Frame	56C	143/145TC	182/184TC	213/215TC	254/256TC	284/286TC	324/326TC	364/365TC
HP	1/4 to 1-1/2	1, 1-1/2, 2	3, 5	7-1/2, 10	15, 20	25, 30	40, 50	60, 75

* **Thermal HP Limit**

Base Module Size	KL2	K1	K2	K3	K4	K5	K6	K7	K8	K9	K10
HP Limit	3.017	2.95	5.36	7.38	12.34	14.75	20.12	29.50	40.23	53.63	67.05

K/KL Series: RIGHT ANGLE — Solid Shaft/Hollow Output

1750 RPM Input		Nominal Ratio	Overhung Load Output Shaft ¹⁾ (lbs)	Part Number Codes (in blue)		
Input HP	Output Torque (lb-in)			Base Module	Motor Adapter/ NEMA Motor	Compatible NEMA C-Frame ²⁾ with Designated Motor Adapter
325 RPM Output (Approximate)						
8.73*	1,640	5.375	621	K302_0054	MR160/050	56C
					MR160/140	143/145TC
9.22	1,747	5.422	997	K402_0054	MR160/050	56C
					MR160/140	143/145TC
10.07*	1,892	5.375	621	K302_0054	MR200/180	182/184TC
15.02*	2,847	5.422	997	K402_0054	MR200/180	182/184TC
					MR250/210	213/215TC
315 RPM Output (Approximate)						
3.14*	612	5.568	449	K102_0056	MR160/050	56C
					MR160/140	143/145TC
245 RPM Output (Approximate)						
4.77	1,186	7.118	585	K202_0071	MR160/050	56C
					MR160/140	143/145TC
235 RPM Output (Approximate)						
8.14*	2,104	7.391	691	K302_0074	MR160/050	56C
					MR160/140	143/145TC
					MR200/180	182/184TC
9.22	2,402	7.456	1,109	K402_0075	MR160/050	56C
					MR160/140	143/145TC
12.14	3,166	7.456	1,109	K402_0075	MR200/180	182/184TC
					MR250/210	213/215TC
21.97*	5,562	7.347	1,325	K513_0073	MR200/180	182/184TC
23.08*	5,842	7.347	1,325	K513_0073	MR250/210	213/215TC
24.58*	6,201	7.323	1,575	K613_0073	MR200/180	182/184TC
24.58	6,305	7.445	2,870	K813_0074	MR200/180	182/184TC
24.58	6,405	7.563	2,189	K713_0076	MR200/180	182/184TC
30.56*	7,712	7.323	1,575	K613_0073	MR250/210	213/215TC
					MR300/250	254/256TC
					MR300/280	284/286TC
39.32	10,087	7.445	2,870	K813_0074	MR250/210	213/215TC
39.32*	10,247	7.563	2,189	K713_0076	MR250/210	213/215TC
48.95*	12,757	7.563	2,189	K713_0076	MR300/250	254/256TC
					MR300/280	284/286TC
73.72*	18,914	7.445	2,870	K813_0074	MR300/250	254/256TC
					MR300/280	284/286TC

1) Overhung Load is measured at the center of the shaft extension. Hollow output units are not intended to support overhung loads. If a load rating is required, use 50% of the published overhung load.

2) Motor HP for TEFC NEMA C-Frame @ 1750 RPM

Order Code	050	140	180	210	250	280	320	360
C-Frame	56C	143/145TC	182/184TC	213/215TC	254/256TC	284/286TC	324/326TC	364/365TC
HP	1/4 to 1-1/2	1, 1-1/2, 2	3, 5	7-1/2, 10	15, 20	25, 30	40, 50	60, 75

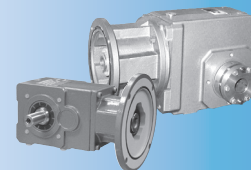

Selection Data

1750 RPM Input		Nominal Ratio	Overhung Load Output Shaft ¹⁾ (lbs)	Part Number Codes (in blue)		
Input HP	Output Torque (lb-in)			Base Module	Motor Adapter/ NEMA Motor	Compatible NEMA C-Frame ²⁾ with Designated Motor Adapter
220 RPM Output (Approximate)						
1.47*	411	8.000	284	KL202_0080	ML2R050	56C
105.20*	28,763	7.934	6,570	K913_0079	MR350/320	324/326TC
215 RPM Output (Approximate)						
21.56*	6,044	8.134	1,371	K513_0081	MR200/180	182/184TC
					MR250/210	213/215TC
24.58*	6,865	8.107	1,629	K613_0081	MR200/180	182/184TC
28.56*	7,978	8.107	1,629	K613_0081	MR250/210	213/215TC
					MR300/250	254/256TC
210 RPM Output (Approximate)						
4.27	1,253	8.397	618	K202_0084	MR160/050	56C
					MR160/140	143/145TC
6.87	2,029	8.444	722	K302_0084	MR160/050	56C
					MR160/140	143/145TC
7.45*	2,199	8.444	722	K302_0084	MR200/180	182/184TC
7.70	2,256	8.377	1,153	K402_0084	MR160/050	56C
					MR160/140	143/145TC
11.24	3,291	8.377	1,153	K402_0084	MR200/180	182/184TC
					MR250/210	213/215TC
24.58	6,980	8.243	2,969	K813_0082	MR200/180	182/184TC
39.32	11,169	8.243	2,969	K813_0082	MR250/210	213/215TC
39.32*	11,345	8.373	2,264	K713_0084	MR250/180	182/184TC
					MR250/210	213/215TC
45.74*	13,197	8.373	2,264	K713_0084	MR300/250	254/256TC
					MR300/280	284/286TC
73.72*	20,941	8.243	2,969	K813_0082	MR300/250	254/256TC
					MR300/280	284/286TC
190 RPM Output (Approximate)						
2.24	725	9.249	532	K102_0092	MR160/050	56C
					MR160/140	143/145TC

K/KL Series: RIGHT ANGLE — Solid Shaft / Hollow Output

* Thermal HP Limit

Base Module Size	KL2	K1	K2	K3	K4	K5	K6	K7	K8	K9	K10
HP Limit	3.017	2.95	5.36	7.38	12.34	14.75	20.12	29.50	40.23	53.63	67.05

K/KL Series: RIGHT ANGLE — Solid Shaft/Hollow Output

1750 RPM Input		Nominal Ratio	Overhung Load Output Shaft ¹⁾ (lbs)	Part Number Codes (in blue)		
Input HP	Output Torque (lb-in)			Base Module	Motor Adapter/ NEMA Motor	Compatible NEMA C-Frame ²⁾ with Designated Motor Adapter
170 RPM Output (Approximate)						
2.11	747	10.140	548	K102_0100	MR160/050	56C
					MR160/140	143/145TC
3.78	1,332	10.073	657	K202_0100	MR160/050	56C
					MR160/140	143/145TC
					MR200/180	182/184TC
5.98	2,117	10.135	768	K302_0100	MR160/050	56C
					MR160/140	143/145TC
6.60	2,337	10.135	768	K302_0100	MR200/180	182/184TC
6.66	2,351	10.098	1,227	K402_0100	MR160/050	56C
					MR160/140	143/145TC
9.92	3,503	10.098	1,227	K402_0100	MR200/180	182/184TC
					MR250/210	213/215TC

150 RPM Output (Approximate)

3.45	1,394	11.546	687	K202_0115	MR160/050	56C
					MR160/140	143/145TC
					MR200/180	182/184TC
6.02	2,445	11.610	803	K302_0115	MR160/050	56C
					MR160/140	143/145TC
					MR200/180	182/184TC
7.70	3,102	11.518	1,282	K402_0115	MR160/050	56C
					MR160/140	143/145TC
9.09	3,660	11.518	1,282	K402_0115	MR200/180	182/184TC
					MR250/210	213/215TC
17.04*	6,791	11.569	1,542	K513_0115	MR200/180	182/184TC
17.05*	6,797	11.569	1,542	K513_0115	MR250/210	213/215TC
19.60	7,702	11.407	1,825	K613_0115	MR200/180	182/184TC
21.48	8,721	11.781	2,537	K713_0120	MR200/180	182/184TC
22.74*	8,939	11.407	1,825	K613_0115	MR250/210	213/215TC
					MR300/250	254/256TC
36.43*	14,788	11.781	2,537	K713_0120	MR250/210	213/215TC
					MR300/250	254/256TC
					MR300/280	284/286TC

1) Overhung Load is measured at the center of the shaft extension. Hollow output units are not intended to support overhung loads. If a load rating is required, use 50% of the published overhung load.

2) Motor HP for TEFC NEMA C-Frame @ 1750 RPM

Order Code	050	140	180	210	250	280	320	360
C-Frame	56C	143/145TC	182/184TC	213/215TC	254/256TC	284/286TC	324/326TC	364/365TC
HP	1/4 to 1-1/2	1, 1-1/2, 2	3, 5	7-1/2, 10	15, 20	25, 30	40, 50	60, 75

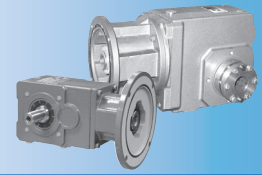

Selection Data

1750 RPM Input		Nominal Ratio	Overhung Load Output Shaft ¹⁾ (lbs)	Part Number Codes (in blue)		
Input HP	Output Torque (lb-in)			Base Module	Motor Adapter/ NEMA Motor	Compatible NEMA C-Frame ²⁾ with Designated Motor Adapter

140 RPM Output (Approximate)

3.24	1,439	12.705	710	K202_0125	MR160/050	56C
					MR160/140	143/145TC
					MR200/180	182/184TC
5.12	2,251	12.577	825	K302_0125	MR160/050	56C
					MR160/140	143/145TC
5.71	2,511	12.577	825	K302_0125	MR200/180	182/184TC
5.86	2,594	12.658	1,323	K402_0125	MR160/050	56C
					MR160/140	143/145TC
8.53	3,777	12.658	1,323	K402_0125	MR200/180	182/184TC
					MR250/210	213/215TC
15.93*	7,032	12.808	1,595	K513_0130	MR200/180	182/184TC
19.60	8,527	12.629	1,888	K613_0125	MR250/210	213/215TC
					MR300/250	254/256TC
21.25*	9,248	12.629	1,888	K613_0125	MR300/180	182/184TC
					MR300/210	213/215TC
73.72*	31,819	12.525	7,650	K913_0125	MR300/250	254/256TC
					MR300/280	284/286TC
					MR350/320	324/326TC
105.20*	45,406	12.525	7,650	K913_0125	MR350/320	324/326TC

125 RPM Output (Approximate)

1.69	835	14.114	612	K102_0140	MR160/050	56C
					MR160/140	143/145TC
3.06	1,481	13.851	730	K202_0140	MR160/050	56C
					MR160/140	143/145TC
					MR200/180	182/184TC
5.33	2,599	13.935	854	K302_0140	MR160/050	56C
					MR160/140	143/145TC
					MR200/180	182/184TC
6.66	3,232	13.885	1,364	K402_0140	MR160/050	56C
					MR160/140	143/145TC
8.02	3,895	13.885	1,364	K402_0140	MR200/180	182/184TC
					MR250/210	213/215TC
21.48	9,655	13.043	2,625	K713_0130	MR200/180	182/184TC
34.04*	15,299	13.043	2,625	K713_0130	MR250/210	213/215TC
					MR300/250	254/256TC
					MR300/280	284/286TC

* Thermal HP Limit

Base Module Size	KL2	K1	K2	K3	K4	K5	K6	K7	K8	K9	K10
HP Limit	3.017	2.95	5.36	7.38	12.34	14.75	20.12	29.50	40.23	53.63	67.05

K/KL Series: RIGHT ANGLE — Solid Shaft / Hollow Output

K/KL Series: RIGHT ANGLE — Solid Shaft/Hollow Output

1750 RPM Input		Nominal Ratio	Overhung Load Output Shaft ¹⁾ (lbs)	Part Number Codes (in blue)		
Input HP	Output Torque (lb-in)			Base Module	Motor Adapter/ NEMA Motor	Compatible NEMA C-Frame ²⁾ with Designated Motor Adapter
120 RPM Output (Approximate)						
22.11	11,309	14.842	3,612	K813_0150	MR200/180	182/184TC
39.12	20,007	14.842	3,612	K813_0150	MR250/210	213/215TC
54.06*	27,647	14.842	3,612	K813_0150	MR300/250	254/256TC
					MR300/280	284/286TC
105 RPM Output (Approximate)						
0.79*	443	16.000	358	KL202_0160	ML2R050	56C
1.51	883	16.714	648	K102_0165	MR160/050	56C
					MR160/140	143/145TC
4.03	2,389	16.939	911	K302_0170	MR160/050	56C
					MR160/140	143/145TC
4.68	2,774	16.939	911	K302_0170	MR200/180	182/184TC
8.68	5,129	17.156	2,091	K613_0170	MR160/050	56C
					MR160/140	143/145TC
15.25	9,014	17.156	2,091	K613_0170	MR200/180	182/184TC
17.32	10,242	17.156	2,091	K613_0170	MR250/210	213/215TC
					MR300/250	254/256TC
22.11	12,521	16.432	3,737	K813_0165	MR200/180	182/184TC
39.12	22,151	16.432	3,737	K813_0165	MR250/210	213/215TC
50.51*	28,601	16.432	3,737	K813_0165	MR300/250	254/256TC
					MR300/280	284/286TC
100 RPM Output (Approximate)						
2.62	1,600	17.469	789	K202_0175	MR160/050	56C
					MR160/140	143/145TC
4.62	2,793	17.293	917	K302_0175	MR160/050	56C
					MR160/140	143/145TC
					MR200/180	182/184TC
5.86	3,567	17.405	1,471	K402_0175	MR160/050	56C
					MR160/140	143/145TC
6.90	4,200	17.405	1,471	K402_0175	MR200/180	182/184TC
7.57	4,556	17.481	1,769	K513_0175	MR160/050	56C
					MR160/140	143/145TC
12.95	7,800	17.481	1,769	K513_0175	MR200/180	182/184TC
					MR250/210	213/215TC

1) Overhung Load is measured at the center of the shaft extension. Hollow output units are not intended to support overhung loads. If a load rating is required, use 50% of the published overhung load.

2) Motor HP for TEFC NEMA C-Frame @ 1750 RPM

Order Code	050	140	180	210	250	280	320	360
C-Frame	56C	143/145TC	182/184TC	213/215TC	254/256TC	284/286TC	324/326TC	364/365TC
HP	1/4 to 1-1/2	1, 1-1/2, 2	3, 5	7-1/2, 10	15, 20	25, 30	40, 50	60, 75

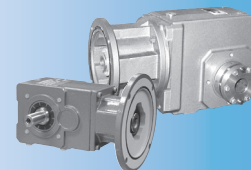

Selection Data

1750 RPM Input		Nominal Ratio	Overhung Load Output Shaft ¹⁾ (lbs)	Part Number Codes (in blue)		
Input HP	Output Torque (lb-in)			Base Module	Motor Adapter/ NEMA Motor	Compatible NEMA C-Frame ²⁾ with Designated Motor Adapter
95 RPM Output (Approximate)						
15.67	9,865	18.275	2,937	K713_0185	MR200/180	182/184TC
27.18	17,119	18.275	2,937	K713_0185	MR250/210	213/215TC
					MR300/250	254/256TC
					MR300/280	284/286TC
90 RPM Output (Approximate)						
7.57	5,044	19.353	1,830	K513_0195	MR160/050	56C
					MR160/140	143/145TC
8.68	5,679	18.994	2,164	K613_0190	MR160/050	56C
					MR160/140	143/145TC
11.95	7,972	19.353	1,830	K513_0195	MR200/180	182/184TC
					MR250/210	213/215TC
15.25	9,980	18.994	2,164	K613_0190	MR200/180	182/184TC
16.19	10,596	18.994	2,164	K613_0190	MR250/210	213/215TC
					MR300/250	254/256TC
					MR300/180	182/184TC
73.72*	48,429	19.063	8,800	K913_0190	MR300/210	213/215TC
					MR300/250	254/256TC
					MR300/280	284/286TC
					MR350/320	324/326TC
83.04*	54,548	19.063	8,800	K913_0190	MR350/360	364/365TC
85 RPM Output (Approximate)						
1.33	940	20.150	690	K102_0200	MR160/050	56C
					MR160/140	143/145TC
2.37	1,683	20.327	830	K202_0200	MR160/050	56C
					MR160/140	143/145TC
3.56	2,526	20.278	967	K302_0200	MR160/050	56C
					MR160/140	143/145TC
4.03	2,849	20.197	1,546	K402_0200	MR160/050	56C
					MR160/140	143/145TC
4.15	2,945	20.278	967	K302_0200	MR200/180	182/184TC
6.25	4,413	20.197	1,546	K402_0200	MR200/180	182/184TC
15.67	10,922	20.233	3,038	K713_0200	MR200/180	182/184TC
25.40	17,710	20.233	3,038	K713_0200	MR250/210	213/215TC
					MR300/250	254/256TC

K/KL Series: RIGHT ANGLE — Solid Shaft / Hollow Output

* Thermal HP Limit

Base Module Size	K1	K2	K3	K4	K5	K6	K7	K8	K9	K10
HP Limit	2.95	5.36	7.38	12.34	14.75	20.12	29.50	40.23	53.63	67.05

K/KL Series: RIGHT ANGLE – Solid Shaft/Hollow Output

1750 RPM Input		Nominal Ratio	Overhung Load Output Shaft ¹⁾ (lbs)	Part Number Codes (in blue)		
Input HP	Output Torque (lb-in)			Base Module	Motor Adapter/ NEMA Motor	Compatible NEMA C-Frame ²⁾ with Designated Motor Adapter
75 RPM Output (Approximate)						
1.21	986	23.265	723	K102_0230	MR160/050	56C
					MR160/140	143/145TC
3.79	3,084	23.292	1,013	K302_0230	MR160/050	56C
					MR160/140	143/145TC
					MR200/180	182/184TC
15.67	12,440	23.044	4,182	K813_0230	MR200/180	182/184TC
27.75	22,036	23.044	4,182	K813_0230	MR250/210	213/215TC
40.32*	32,014	23.044	4,182	K813_0230	MR300/250	254/256TC
					MR300/280	284/286TC
73 RPM Output (Approximate)						
35.15	29,004	23.943	9,495	K913_0240	MR250/180	182/184TC
					MR250/210	213/215TC
62.77*	51,785	23.943	9,495	K913_0240	MR300/250	254/256TC
					MR300/280	284/286TC
71.33*	58,854	23.943	9,495	K913_0240	MR350/320	324/326TC
70 RPM Output (Approximate)						
0.96	851	25.220	743	K102_0250	MR160/050	56C
2.02	1,772	25.130	891	K202_0250	MR160/050	56C
					MR160/140	143/145TC
2.91	2,566	25.259	1,041	K302_0250	MR160/050	56C
					MR160/140	143/145TC
3.34	2,956	25.279	1,666	K402_0250	MR160/050	56C
					MR160/140	143/145TC
3.48	3,070	25.259	1,041	K302_0250	MR200/180	182/184TC
5.02	4,434	25.279	1,666	K402_0250	MR200/180	182/184TC
15.67	13,773	25.513	4,327	K813_0260	MR200/180	182/184TC
27.75	24,397	25.513	4,327	K813_0260	MR250/210	213/215TC

1) Overhung Load is measured at the center of the shaft extension. Hollow output units are not intended to support overhung loads. If a load rating is required, use 50% of the published overhung load.

2) Motor HP for TEFC NEMA C-Frame @ 1750 RPM

Order Code	050	140	180	210	250	280	320	360
C-Frame	56C	143/145TC	182/184TC	213/215TC	254/256TC	284/286TC	324/326TC	364/365TC
HP	1/4 to 1-1/2	1, 1-1/2, 2	3, 5	7-1/2, 10	15, 20	25, 30	40, 50	60, 75

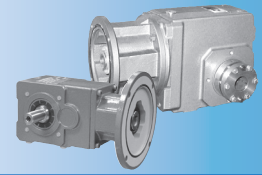

Selection Data

1750 RPM Input		Nominal Ratio	Overhung Load Output Shaft ¹⁾ (lbs)	Part Number Codes (in blue)		
Input HP	Output Torque (lb-in)			Base Module	Motor Adapter/ NEMA Motor	Compatible NEMA C-Frame ²⁾ with Designated Motor Adapter

60 RPM Output (Approximate)

1.07	1,049	28.048	770	K102_0280	MR160/050	56C
					MR160/140	143/145TC
1.81	1,772	27.950	923	K202_0280	MR160/050	56C
					MR160/140	143/145TC
3.18	3,100	27.883	1,076	K302_0280	MR160/050	56C
					MR160/140	143/145TC
					MR200/180	182/184TC
4.03	3,917	27.771	1,719	K402_0280	MR160/050	56C
					MR160/140	143/145TC
5.02	4,872	27.771	1,719	K402_0280	MR200/180	182/184TC
5.11	5,136	29.181	2,099	K513_0290	MR160/050	56C
					MR160/140	143/145TC
5.97	5,923	28.772	2,485	K613_0290	MR160/050	56C
					MR160/140	143/145TC
7.93	7,972	29.181	2,099	K513_0290	MR200/180	182/184TC
					MR250/210	213/215TC
10.48	10,395	28.772	2,485	K613_0290	MR200/180	182/184TC
11.33	11,434	29.285	3,437	K713_0290	MR200/180	182/184TC
12.27	12,169	28.772	2,485	K613_0290	MR250/210	213/215TC
					MR250/210	213/215TC
					MR300/210	213/215TC
19.85	20,033	29.285	3,437	K713_0290	MR300/250	254/256TC

55 RPM Output (Approximate)

0.40*	443	32.000	450	KL202_0320	ML2R050	56C
2.76	3,100	32.649	1,134	K303_0330	MR160/050	56C
					MR160/140	143/145TC
3.34	3,733	32.390	1,809	K403_0320	MR160/050	56C
					MR160/140	143/145TC
5.11	5,687	32.308	2,171	K513_0320	MR160/050	56C
					MR160/140	143/145TC
5.97	6,557	31.855	2,571	K613_0320	MR160/050	56C
					MR160/140	143/145TC
7.16	7,972	32.308	2,171	K513_0320	MR200/180	182/184TC
10.48	11,508	31.855	2,571	K613_0320	MR200/180	182/184TC
11.33	12,659	32.423	3,555	K713_0320	MR200/180	182/184TC
11.47	12,589	31.855	2,571	K613_0320	MR250/210	213/215TC
					MR250/210	213/215TC
18.55	20,724	32.423	3,555	K713_0320	MR300/250	254/256TC

* Thermal HP Limit

Base Module Size	K1	K2	K3	K4	K5	K6	K7	K8	K9	K10
HP Limit	2.95	5.36	7.38	12.34	14.75	20.12	29.50	40.23	53.63	67.05

K/KL Series: RIGHT ANGLE — Solid Shaft / Hollow Output

K/KL Series: RIGHT ANGLE — Solid Shaft/Hollow Output

1750 RPM Input		Nominal Ratio	Overhung Load Output Shaft ¹⁾ (lbs)	Part Number Codes (in blue)		
Input HP	Output Torque (lb-in)			Base Module	Motor Adapter/ NEMA Motor	Compatible NEMA C-Frame ²⁾ with Designated Motor Adapter
55 RPM Output (Approximate) Continued						
27.75	30,711	32.116	10,471	K913_0320	MR250/180	182/184TC
					MR250/210	213/215TC
49.56	54,851	32.116	10,471	K913_0320	MR300/250	254/256TC
					MR300/280	284/286TC
56.03*	62,006	32.116	10,471	K913_0320	MR350/320	364/365TC
58.79	63,887	31.535	12,810	K1013_0320	MR300/180	182/184TC
					MR300/210	213/215TC
					MR300/250	254/256TC
					MR300/280	284/286TC
78.29*	85,073	31.535	12,810	K1013_0320	MR350/320	324/326TC
					MR350/360	364/365TC
52 RPM Output (Approximate)						
0.55	647	33.707	819	K102_0340	MR140/050	56C
1.16	1,364	33.618	981	K202_0340	MR160/050	56C
					MR160/140	143/145TC
1.89	2,217	33.618	1,145	K302_0340	MR160/050	56C
					MR160/140	143/145TC
2.62	3,084	33.678	1,833	K402_0340	MR160/050	56C
					MR160/140	143/145TC
50 RPM Output (Approximate)						
0.87	1,063	35.105	830	K102_0350	MR160/050	56C
1.47	1,772	34.554	990	K202_0350	MR160/050	56C
					MR160/140	143/145TC
2.55	3,100	34.731	1,157	K302_0350	MR160/050	56C
					MR160/140	143/145TC
4.01	4,872	34.758	1,852	K402_0350	MR200/180	182/184TC
4.50	5,402	34.800	2,226	K513_0350	MR160/050	56C
					MR160/140	143/145TC
6.65	7,972	34.800	2,226	K513_0350	MR200/180	182/184TC
11.33	14,109	36.138	4,859	K813_0360	MR200/180	182/184TC
19.95	24,839	36.138	4,859	K813_0360	MR250/210	213/215TC
29.87	37,194	36.138	4,859	K813_0360	MR300/250	254/256TC
					MR300/280	284/286TC

1) Overhung Load is measured at the center of the shaft extension. Hollow output units are not intended to support overhung loads. If a load rating is required, use 50% of the published overhung load.

2) Motor HP for TEFC NEMA C-Frame @ 1750 RPM

Order Code	050	140	180	210	250	280	320	360
C-Frame	56C	143/145TC	182/184TC	213/215TC	254/256TC	284/286TC	324/326TC	364/365TC
HP	1/4 to 1-1/2	1, 1-1/2, 2	3, 5	7-1/2, 10	15, 20	25, 30	40, 50	60, 75

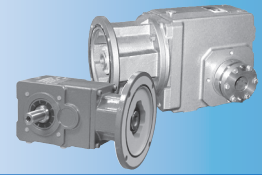

Selection Data

1750 RPM Input		Nominal Ratio	Overhung Load Output Shaft ¹⁾ (lbs)	Part Number Codes (in blue)		
Input HP	Output Torque (lb-in)			Base Module	Motor Adapter/ NEMA Motor	Compatible NEMA C-Frame ²⁾ with Designated Motor Adapter
45 RPM Output (Approximate)						
1.30	1,772	39.454	1,035	K203_0390	MR140/050	56C
2.30	3,100	39.187	1,205	K303_0390	MR160/050	56C
					MR160/140	143/145TC
3.34	4,500	39.047	1,926	K403_0390	MR160/050	56C
					MR160/140	143/145TC
4.50	5,981	38.529	2,302	K513_0390	MR160/050	56C
					MR160/140	143/145TC
6.01	7,972	38.529	2,302	K513_0390	MR200/180	182/184TC
					MR250/180	182/184TC
24.72	32,411	38.042	11,079	K913_0380	MR250/210	213/215TC
					MR300/250	254/256TC
43.99	57,666	38.042	11,079	K913_0380	MR300/280	284/286TC
					MR350/320	324/326TC
47.30	62,006	38.042	11,079	K913_0380	MR300/180	182/184TC
					MR300/210	213/215TC
50.44	67,096	38.601	13,703	K1013_0390	MR300/250	254/256TC
					MR300/280	284/286TC
67.07*	89,219	38.601	13,703	K1013_0390	MR350/320	324/326TC
					MR350/360	364/365TC

43 RPM Output (Approximate)						
0.38	541	40.300	869	K102_0400	MR140/050	56C
1.20	1,705	40.512	1,218	K302_0410	MR160/050	56C
					MR160/140	143/145TC
1.93	2,729	40.512	1,950	K402_0410	MR160/050	56C
					MR160/140	143/145TC
11.33	15,621	40.009	5,027	K813_0400	MR200/180	182/184TC
19.95	27,499	40.009	5,027	K813_0400	MR250/210	213/215TC
26.99	37,204	40.009	5,027	K813_0400	MR300/250	254/256TC
					MR300/280	284/286TC

40 RPM Output (Approximate)						
0.55	900	46.918	914	K102_0470	MR140/050	56C
1.10	1,772	46.225	1,091	K202_0460	MR160/050	56C
					MR160/140	143/145TC
1.89	3,048	46.225	1,273	K302_0460	MR160/050	56C
					MR160/140	143/145TC
2.01	3,100	44.892	1,261	K303_0450	MR160/050	56C
					MR160/140	143/145TC

* Thermal HP Limit

Base Module Size	K1	K2	K3	K4	K5	K6	K7	K8	K9	K10
HP Limit	2.95	5.36	7.38	12.34	14.75	20.12	29.50	40.23	53.63	67.05

K/KL Series: RIGHT ANGLE — Solid Shaft / Hollow Output

K/KL Series: RIGHT ANGLE — Solid Shaft/Hollow Output

1750 RPM Input		Nominal Ratio	Overhung Load Output Shaft ¹⁾ (lbs)	Part Number Codes (in blue)		
Input HP	Output Torque (lb-in)			Base Module	Motor Adapter/ NEMA Motor	Compatible NEMA C-Frame ²⁾ with Designated Motor Adapter
40 RPM Output (Approximate) Continued						
2.62	4,240	46.308	2,038	K402_0460	MR160/050	56C
					MR160/140	143/145TC
3.17	4,872	44.536	2,012	K403_0450	MR160/050	56C
					MR160/140	143/145TC
4.22	6,261	43.111	2,843	K613_0430	MR160/050	56C
					MR160/140	143/145TC
7.38	10,965	43.111	2,843	K613_0430	MR200/180	182/184TC
8.00	12,417	45.054	3,967	K713_0450	MR200/180	182/184TC
8.65	12,844	43.111	2,843	K613_0430	MR250/180	182/184TC
					MR250/210	213/215TC
13.69	21,259	45.054	3,967	K713_0450	MR250/180	182/184TC
					MR250/210	213/215TC

35 RPM Output (Approximate)

1.03	1,772	49.759	1,118	K203_0500	MR140/050	56C
1.85	3,100	48.631	1,295	K303_0491	MR160/050	56C
					MR160/140	143/145TC
2.89	4,872	48.944	2,076	K403_0490	MR160/050	56C
					MR160/140	143/145TC
4.22	6,932	47.730	2,941	K613_0480	MR160/050	56C
					MR160/140	143/145TC
7.38	12,140	47.730	2,941	K613_0480	MR200/180	182/184TC
7.81	12,844	47.730	2,941	K613_0480	MR250/180	182/184TC
8.00	13,747	49.881	4,104	K713_0500	MR200/180	182/184TC
12.37	21,259	49.881	4,104	K713_0500	MR250/180	182/184TC
					MR250/210	213/215TC
19.95	33,636	48.937	12,050	K913_0490	MR250/180	182/184TC
					MR250/210	213/215TC
35.44	59,756	48.937	12,050	K913_0490	MR300/250	254/256TC
					MR300/280	284/286TC
41.49	69,403	48.543	14,790	K1013_0490	MR300/180	182/184TC
					MR300/210	213/215TC
					MR300/250	254/256TC
					MR300/280	284/286TC
55.15	92,250	48.543	14,790	K1013_0490	MR350/320	324/326TC

1) Overhung Load is measured at the center of the shaft extension. Hollow output units are not intended to support overhung loads. If a load rating is required, use 50% of the published overhung load.

2) Motor HP for TEFC NEMA C-Frame @ 1750 RPM

Order Code	050	140	180	210	250	280	320	360
C-Frame	56C	143/145TC	182/184TC	213/215TC	254/256TC	284/286TC	324/326TC	364/365TC
HP	1/4 to 1-1/2	1, 1-1/2, 2	3, 5	7-1/2, 10	15, 20	25, 30	40, 50	60, 75

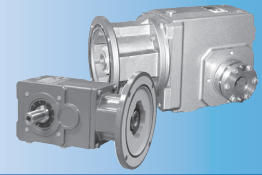

Selection Data

1750 RPM Input		Nominal Ratio	Overhung Load Output Shaft ¹⁾ (lbs)	Part Number Codes (in blue)		
Input HP	Output Torque (lb-in)			Base Module	Motor Adapter/ NEMA Motor	Compatible NEMA C-Frame ²⁾ with Designated Motor Adapter
30 RPM Output (Approximate)						
0.38	753	56.095	970	K102_0560	MR140/050	56C
0.95	1,772	54.250	1,151	K203_0540	MR140/050	56C
1.20	2,345	55.705	1,355	K302_0560	MR160/050	56C
					MR160/140	143/145TC
1.67	3,100	53.883	1,340	K303_0540	MR160/050	56C
					MR160/140	143/145TC
1.93	3,752	55.705	2,168	K402_0560	MR160/050	56C
					MR160/140	143/145TC
2.63	4,872	53.690	2,141	K403_0540	MR160/050	56C
					MR160/140	143/145TC
2.84	5,699	58.297	2,643	K513_0580	MR160/050	56C
					MR160/140	143/145TC
3.97	7,972	58.297	2,643	K513_0580	MR200/180	182/184TC
7.37	15,014	59.082	5,724	K813_0590	MR200/180	182/184TC
13.00	26,457	59.082	5,724	K813_0590	MR250/180	182/184TC
					MR250/210	213/215TC
18.27	37,204	59.082	5,724	K813_0590	MR300/210	213/215TC
					MR300/250	254/256TC

27 RPM Output (Approximate)						
1.35	3,100	66.868	1,440	K303_0670	MR160/050	56C
					MR160/140	143/145TC
1.37	3,100	65.499	1,430	K303_0650	MR160/050	56C
					MR160/140	143/145TC
2.84	6,310	64.544	2,734	K513_0650	MR160/050	56C
					MR160/140	143/145TC
3.58	7,972	64.544	2,734	K513_0650	MR200/180	182/184TC
7.37	16,622	65.412	5,922	K813_0650	MR200/180	182/184TC
13.00	29,292	65.412	5,922	K813_0650	MR250/180	182/184TC
					MR250/210	213/215TC
15.85	34,454	63.071	13,113	K913_0630	MR250/180	182/184TC
					MR250/210	213/215TC
16.51	37,204	65.412	5,922	K813_0650	MR300/210	213/215TC
					MR300/250	254/256TC
28.20	61,289	63.071	13,113	K913_0630	MR300/210	213/215TC
					MR300/250	254/256TC
					MR300/280	284/286TC
34.03	72,176	61.553	16,009	K1013_0620	MR300/180	182/184TC
					MR300/210	213/215TC
					MR300/250	254/256TC
					MR300/280	284/286TC

K/KL Series: RIGHT ANGLE — Solid Shaft / Hollow Output

* Thermal HP Limit

Base Module Size	KL2	K1	K2	K3	K4	K5	K6	K7	K8	K9	K10
HP Limit	3.017	2.95	5.36	7.38	12.34	14.75	20.12	29.50	40.23	53.63	67.05

K/KL Series: RIGHT ANGLE — Solid Shaft/Hollow Output

1750 RPM Input		Nominal Ratio	Overhung Load Output Shaft ¹⁾ (lbs)	Part Number Codes (in blue)		
Input HP	Output Torque (lb-in)			Base Module	Motor Adapter/ NEMA Motor	Compatible NEMA C-Frame ²⁾ with Designated Motor Adapter
25 RPM Output (Approximate)						
0.72	1,770	68.419	1349	K203_0680	MR140/050	56C
2.43	5,877	70.083	2,810	K513_0700	MR160/050	56C
					MR160/140	143/145TC
2.84	6,723	68.772	3,322	K613_0690	MR160/050	56C
					MR160/140	143/145TC
4.91	11,639	68.772	3,322	K613_0690	MR200/180	182/184TC
5.47	13,414	71.203	4,621	K713_0710	MR200/180	182/184TC
6.42	15,852	71.701	6,106	K813_0720	MR200/180	182/184TC
7.84	19,244	71.203	4,621	K713_0710	MR250/180	182/184TC
11.26	27,814	71.701	6,106	K813_0720	MR250/210	213/215TC
23 RPM Output (Approximate)						
2.84	7,443	76.140	3,437	K613_0760	MR160/050	56C
					MR160/140	143/145TC
4.90	12,844	76.140	3,437	K613_0760	MR200/180	182/184TC
14.04	36,283	75.004	13,893	K913_0750	MR250/180	182/184TC
					MR250/210	213/215TC
23.56	60,903	75.004	13,893	K913_0750	MR300/210	213/215TC
					MR300/250	254/256TC
28.20	73,149	75.276	17,119	K1013_0750	MR300/180	182/184TC
					MR300/210	213/215TC
					MR300/250	254/256TC
					MR300/280	284/286TC
22 RPM Output (Approximate)						
0.65	1,772	79.615	1,308	K203_0800	MR140/050	56C
1.15	3,100	78.410	1,518	K303_0780	MR160/050	56C
					MR160/140	143/145TC
1.81	4,872	78.095	2,426	K403_0780	MR160/050	56C
					MR160/140	143/145TC
2.43	6,506	77.592	2,907	K513_0780	MR160/050	56C
					MR160/140	143/145TC
5.47	14,851	78.832	4,781	K713_0790	MR200/180	182/184TC
6.42	17,551	79.384	6,317	K813_0790	MR200/180	182/184TC
7.83	21,259	78.832	4,781	K713_0790	MR250/180	182/184TC
11.26	30,795	79.384	6,317	K813_0790	MR250/180	182/184TC
					MR250/210	213/215TC
12.93	35,365	79.384	6,317	K813_0790	MR300/210	213/215TC

1) Overhung Load is measured at the center of the shaft extension. Hollow output units are not intended to support overhung loads. If a load rating is required, use 50% of the published overhung load.

2) Motor HP for TEFC NEMA C-Frame @ 1750 RPM

Order Code	050	140	180	210	250	280	320	360
C-Frame	56C	143/145TC	182/184TC	213/215TC	254/256TC	284/286TC	324/326TC	364/365TC
HP	1/4 to 1-1/2	1, 1-1/2, 2	3, 5	7-1/2, 10	15, 20	25, 30	40, 50	60, 75

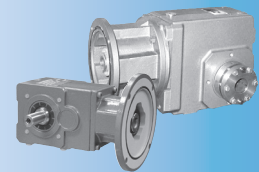

Selection Data

1750 RPM Input		Nominal Ratio	Overhung Load Output Shaft ¹⁾ (lbs)	Part Number Codes (in blue)		
Input HP	Output Torque (lb-in)			Base Module	Motor Adapter/ NEMA Motor	Compatible NEMA C-Frame ²⁾ with Designated Motor Adapter
20 RPM Output (Approximate)						
12.34	37,204	88.885	6,525	K814_0890	MR250/180	182/184TC
					MR250/210	213/215TC
19 RPM Output (Approximate)						
1.00	3,100	90.061	1,575	K303_0900	MR160/050	56C
15.22	47,672	92.352	14,625	K914_0920	MR250/180	182/184TC
					MR250/210	213/215TC
18 RPM Output (Approximate)						
11.15	37,204	98.408	6,525	K814_0980	MR250/180	182/184TC
					MR250/210	213/215TC
16 RPM Output (Approximate)						
0.47	1,772	109.471	1,350	K203_1090	MR140/050	56C
0.83	3,100	107.814	1,575	K303_1080	MR160/050	56C
					MR160/140	143/145TC
1.32	4,872	107.381	2,520	K403_1070	MR160/050	56C
					MR160/140	143/145TC
2.08	7,972	112.834	3,026	K514_1130	MR160/050	56C
					MR160/140	143/145TC
3.34	12,621	111.254	3,600	K614_1110	MR160/050	56C
					MR160/140	143/145TC
5.47	21,259	114.700	4,950	K714_1150	MR200/180	182/184TC
6.54	25,415	114.579	6,525	K814_1150	MR200/180	182/184TC
9.72	37,204	112.838	6,525	K814_1130	MR250/180	182/184TC
					MR250/210	213/215TC
14 RPM Output (Approximate)						
1.88	7,972	124.924	3,026	K514_1250	MR160/050	56C
					MR160/140	143/145TC
3.08	12,844	123.174	3,600	K614_1230	MR160/050	56C
					MR160/140	143/145TC
4.94	21,259	126.990	4,950	K714_1270	MR200/180	182/184TC
6.54	27,901	125.788	14,625	K914_1260	MR200/180	182/184TC
14.76	62,006	123.877	14,625	K914_1240	MR250/180	182/184TC
					MR250/210	213/215TC

K/KL Series: RIGHT ANGLE — Solid Shaft / Hollow Output

* Thermal HP Limit

Base Module Size	K1	K2	K3	K4	K5	K6	K7	K8	K9	K10
HP Limit	2.95	5.36	7.38	12.34	14.75	20.12	29.50	40.23	53.63	67.05

K/KL Series: RIGHT ANGLE — Solid Shaft/Hollow Output

1750 RPM Input		Nominal Ratio	Overhung Load Output Shaft ¹⁾ (lbs)	Part Number Codes (in blue)		
Input HP	Output Torque (lb-in)			Base Module	Motor Adapter/ NEMA Motor	Compatible NEMA C-Frame ²⁾ with Designated Motor Adapter
13 RPM Output (Approximate)						
0.38	1,772	135.335	1,350	K203_1350	MR140/050	56C
0.63	3,098	136.029	1574	K303_1360	MR140/050	56C
0.67	3,100	134.292	1,575	K303_1340	MR160/050	56C
0.99	4,868	136.137	2518	K403_1360	MR140/050	56C
1.05	4,872	134.399	2,520	K403_1340	MR160/050	56C
1.75	7,972	134.560	3,026	K514_1350	MR160/050	56C
					MR160/140	143/145TC
6.54	31,395	141.539	6,525	K814_1420	MR200/180	182/184TC
7.87	37,204	139.388	6,525	K814_1390	MR250/180	182/184TC
12 RPM Output (Approximate)						
1.58	7,972	148.977	3,026	K514_1490	MR160/050	56C
					MR160/140	143/145TC
5.94	31,894	148.996	14613	K914_1490	MR250/180	182/184TC
					MR250/210	213/215TC
11.72	61,955	146.732	14613	K914_1470	MR250/180	182/184TC
					MR250/210	213/215TC
15.22	76,857	148.889	18,000	K1014_1490	MR250/180	182/184TC
					MR250/210	213/215TC
11 RPM Output (Approximate)						
5.94	33,544	156.703	6519	K814_1570	MR200/180	182/184TC
6.54	34,759	156.703	6,525	K814_1570	MR200/180	182/184TC
6.69	37,173	154.322	6519	K814_1540	MR250/180	182/184TC
					MR250/210	213/215TC
7.11	37,204	154.322	6,525	K814_1540	MR250/180	182/184TC

1) Overhung Load is measured at the center of the shaft extension. Hollow output units are not intended to support overhung loads. If a load rating is required, use 50% of the published overhung load.

2) Motor HP for TEFC NEMA C-Frame @ 1750 RPM

Order Code	050	140	180	210	250	280	320	360
C-Frame	56C	143/145TC	182/184TC	213/215TC	254/256TC	284/286TC	324/326TC	364/365TC
HP	1/4 to 1-1/2	1, 1-1/2, 2	3, 5	7-1/2, 10	15, 20	25, 30	40, 50	60, 75

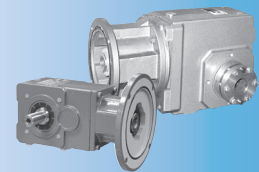

Selection Data

1750 RPM Input		Nominal Ratio	Overhung Load Output Shaft ¹⁾ (lbs)	Part Number Codes (in blue)		
Input HP	Output Torque (lb-in)			Base Module	Motor Adapter/ NEMA Motor	Compatible NEMA C-Frame ²⁾ with Designated Motor Adapter
10 RPM Output (Approximate)						
0.28	1,772	181.048	1,350	K203_1810	MR140/050	56C
0.47	3,046	181.048	1574	K303_1810	MR140/050	56C
0.50	3,048	178.737	1,575	K303_1790	MR160/050	56C
0.72	4,733	181.372	2518	K403_1810	MR140/050	56C
0.77	4,737	179.056	2,520	K403_1790	MR160/050	56C
2.63	15,514	174.209	4,950	K714_1740	MR160/050	56C
					MR160/140	143/145TC
3.55	21,259	176.462	4,950	K714_1760	MR200/180	182/184TC
9 RPM Output (Approximate)						
2.05	12,844	184.554	3,600	K614_1850	MR160/050	56C
					MR160/140	143/145TC
2.63	17,176	192.874	4,950	K714_1930	MR160/050	56C
					MR160/140	143/145TC
3.21	21,259	195.368	4,950	K714_1950	MR200/180	182/184TC
6.54	42,515	191.670	14,625	K914_1920	MR200/180	182/184TC
9.69	62,006	188.757	14,625	K914_1890	MR250/180	182/184TC
					MR250/210	213/215TC
8 RPM Output (Approximate)						
0.31	2,345	218.176	1,575	K303_2180	MR140/050	56C
0.48	3,753	218.176	2518	K403_2180	MR140/050	56C
0.51	3,752	215.391	2,520	K403_2150	MR160/050	56C
1.04	7,972	225.417	3,026	K514_2250	MR160/050	56C
4.81	37,204	227.888	6,525	K814_2280	MR250/180	182/184TC
7 RPM Output (Approximate)						
0.94	7,972	249.569	3,026	K514_2500	MR160/050	56C
1.29	11,639	265.917	3,600	K614_2660	MR160/050	56C
					MR160/140	143/145TC
4.09	37,173	252.304	3813	K814_2520	MR250/180	182/184TC
					MR250/210	213/215TC
4.28	37,204	256.198	6,525	K814_2560	MR200/180	182/184TC
5.72	47,896	247.029	14,625	K914_2470	MR200/180	182/184TC
7.52	62,006	243.275	14,625	K914_2430	MR250/180	182/184TC
11.16	89,859	237.418	18,000	K1014_2370	MR250/180	182/184TC

K/KL Series: RIGHT ANGLE — Solid Shaft / Hollow Output

* Thermal HP Limit

Base Module Size	K1	K2	K3	K4	K5	K6	K7	K8	K9	K10
HP Limit	2.95	5.36	7.38	12.34	14.75	20.12	29.50	40.23	53.63	67.05

K/KL Series: RIGHT ANGLE — Solid Shaft/Hollow Output

1750 RPM Input		Nominal Ratio	Overhung Load Output Shaft ¹⁾ (lbs)	Part Number Codes (in blue)		
Input HP	Output Torque (lb-in)			Base Module	Motor Adapter/ NEMA Motor	Compatible NEMA C-Frame ²⁾ with Designated Motor Adapter
6 RPM Output (Approximate)						
0.78	7,972	300.023	3,026	K514_3000	MR160/050	56C
0.79	7,268	270.989	3,026	K514_2710	MR160/050	56C
1.29	12,844	294.408	3,600	K614_2940	MR160/050	56C
					MR160/140	143/145TC
2.06	21,259	304.817	4,950	K714_3050	MR160/050	56C
					MR160/140	143/145TC
2.06	19,244	275.319	4,950	K714_2750	MR160/050	56C
					MR160/140	143/145TC
3.35	31,935	280.830	6,525	K814_2810	MR200/180	182/184TC
3.35	35,365	310.919	6,525	K814_3110	MR200/180	182/184TC
3.41	31,935	276.563	6,525	K814_2770	MR250/180	182/184TC
3.41	35,365	306.194	6,525	K814_3060	MR250/180	182/184TC
4.82	47,993	293.764	14,625	K914_2940	MR200/180	182/184TC
9.17	90,262	290.350	18,000	K1014_2900	MR250/180	182/184TC
					MR250/210	213/215TC

NOTE: For slower speeds than those shown, units can be combined. Contact STÖBER Drives Inc.

1) Overhung Load is measured at the center of the shaft extension. Hollow output units are not intended to support overhung loads. If a load rating is required, use 50% of the published overhung load.

2) Motor HP for TEFC NEMA C-Frame @ 1750 RPM

Order Code	050	140	180	210	250	280	320	360
C-Frame	56C	143/145TC	182/184TC	213/215TC	254/256TC	284/286TC	324/326TC	364/365TC
HP	1/4 to 1-1/2	1, 1-1/2, 2	3, 5	7-1/2, 10	15, 20	25, 30	40, 50	60, 75

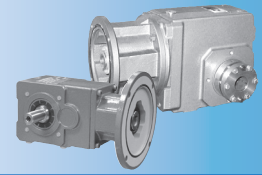

Selection Data

KL Series with "A" Hollow Output

"G" Pilot Circle Diameter (PCD) Tapped Holes

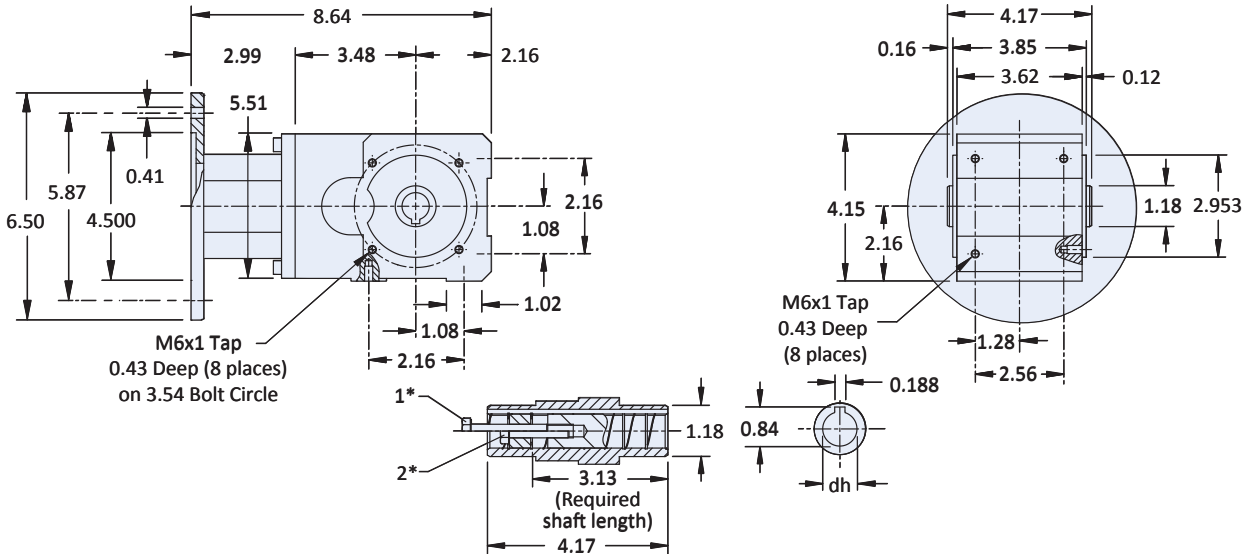

KL Series with "A" Hollow Output

"F" Output Flange Housing

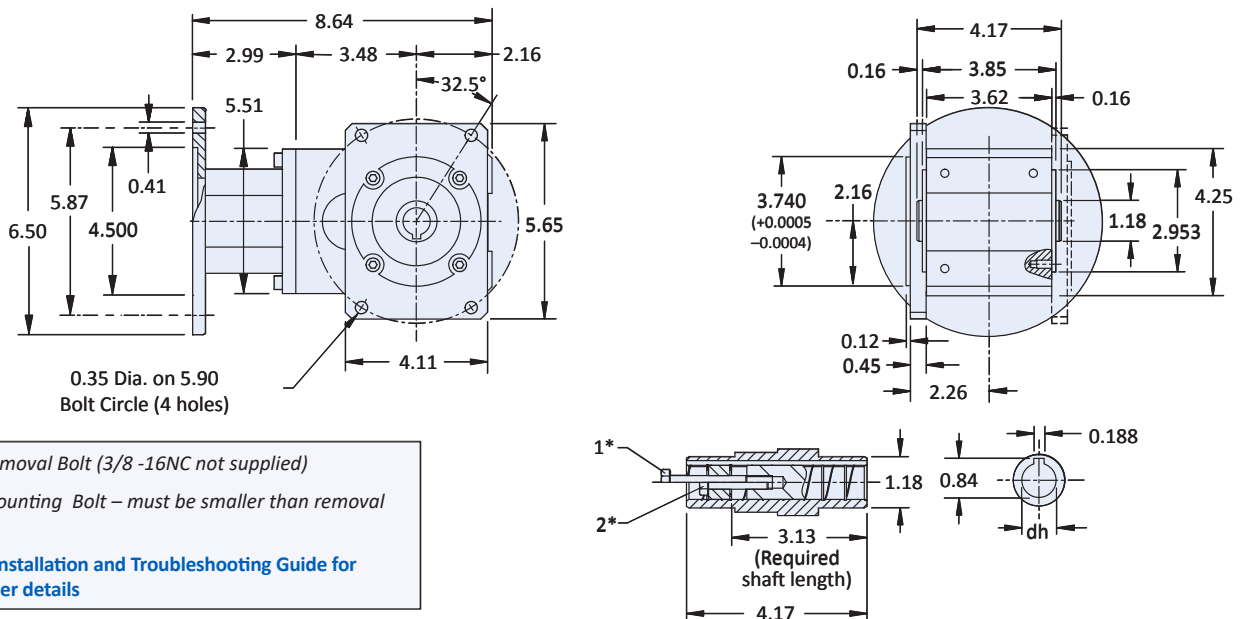

- * 1. Removal Bolt (3/8 -16NC not supplied)
 - 2. Mounting Bolt – must be smaller than removal bolt
- See Installation and Troubleshooting Guide for further details

"A" Hollow Bore Output Options

BLUE designates standard hollow output diameters. Black designates optional diameters readily available from inventory.

	Carbon Steel		Stainless Steel*	
	Inches	Metric	Inches	Metric
Dimension "dh"	3/4	20	3/4	20

* Stainless steel is ideal for food and beverage or harsh washdown environments.

K/KL Series: RIGHT ANGLE — Solid Shaft / Hollow Output

K/KL Series: RIGHT ANGLE — Solid Shaft/Hollow Output

KL Series with "P" Solid Shaft Output

"F" Output Flange Housing

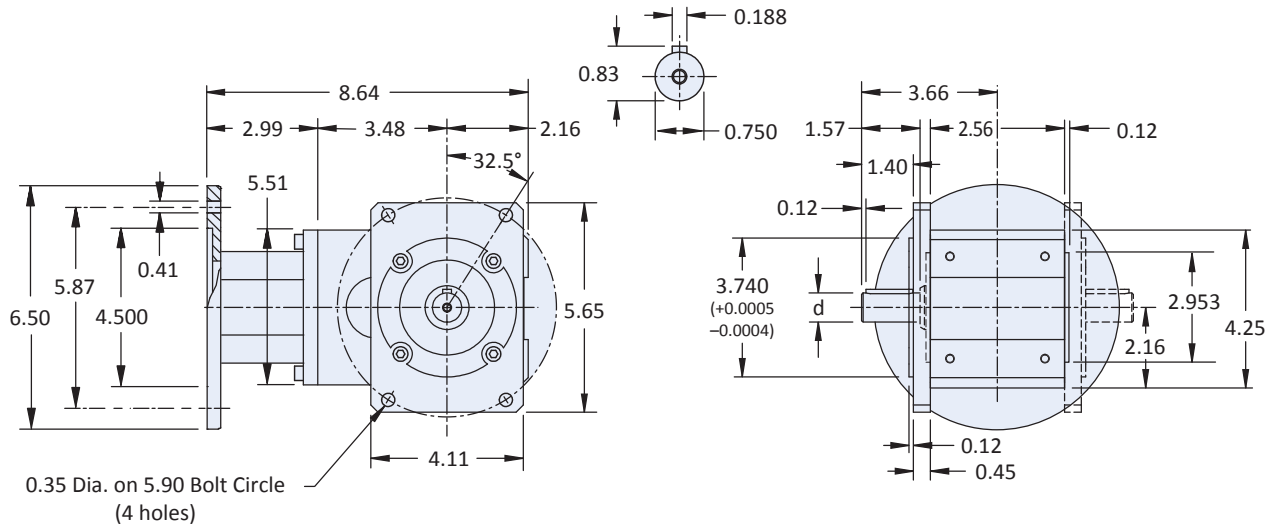

KL Series with "P" Solid Shaft Output

"NG" Foot Mounting Housing

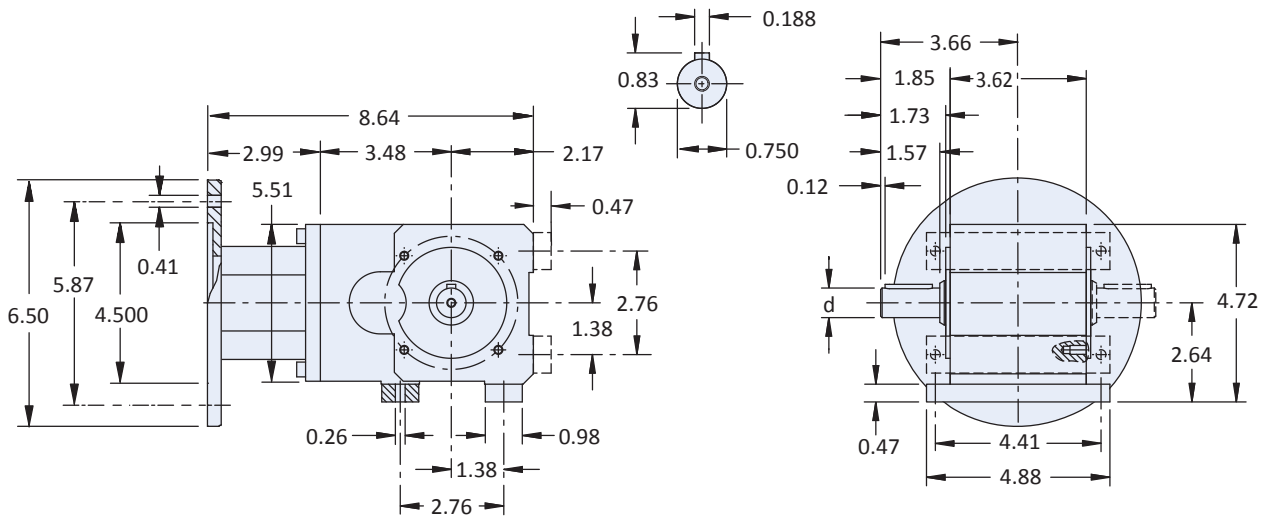

"P" Solid Shaft Output Options

BLUE designates standard shaft diameters. Black designates optional diameters readily available from inventory.

	Carbon Steel		Stainless Steel*	
	Inches	Metric	Inches	Metric
Dimension "d"	3/4	20	3/4	20

* Stainless steel is ideal for food and beverage or harsh washdown environments.

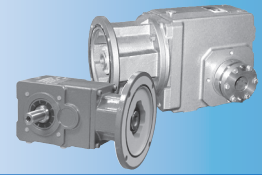

Dimensional Data

KL Series (KL202 only) with "W" Wobble Free Bushing Output

"G" Pilot Circle Diameter (PCD) Tapped Holes

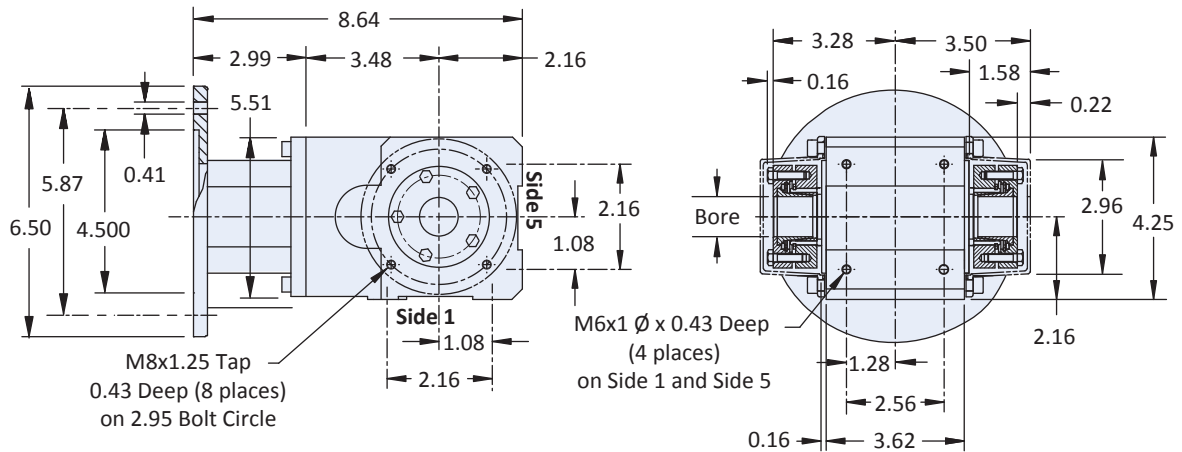

Important: A 1/32" x 45° chamfer minimum is recommended for the shaft end. The bushing will accept a shaft with a tolerance of +0.000/-0.005 inches.

K/KL Series: RIGHT ANGLE — Solid Shaft / Hollow Output

"WFB" Wobble Free Double Bushing Output

BLUE designates standard bore diameter.

	Carbon Steel		Stainless Steel*	
	Inches	Metric	Inches	Metric
Bore	—	—	3/4	—
Part Number	—	—	WFBKL2-012	—

* Stainless steel is ideal for food and beverage or harsh washdown environments.

"A" Hollow Bore Output with "GD" Torque Arm Bracket

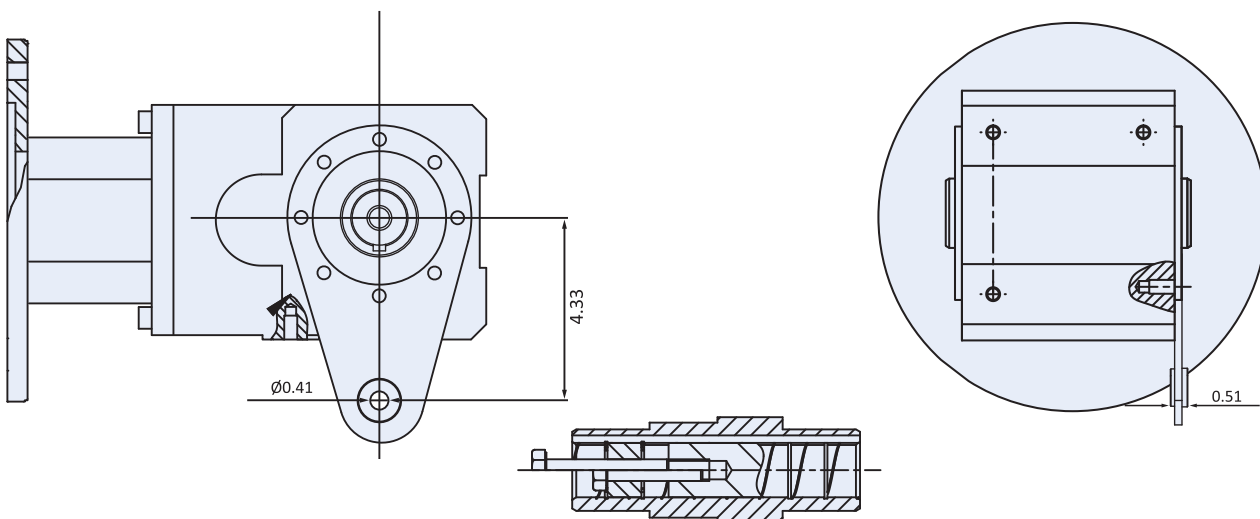

K/KL Series: RIGHT ANGLE — Solid Shaft/Hollow Output

K Series with “A” Hollow Output

“GD” Torque Arm Bracket Housing (Torque arm supplied by others)

K102AGD thru K403AGD

Important:

On K102 thru K1014, brackets can be mounted on Side 1 (shown) or Side 5 (opposite input side).
On K102 ONLY, the bracket can also be mounted on Side 2 (top).

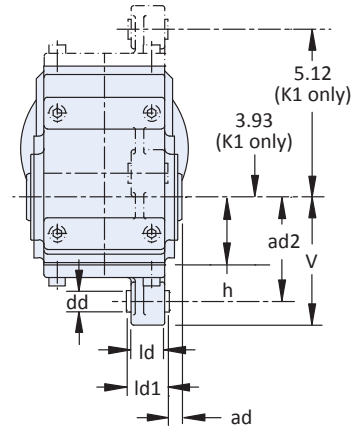
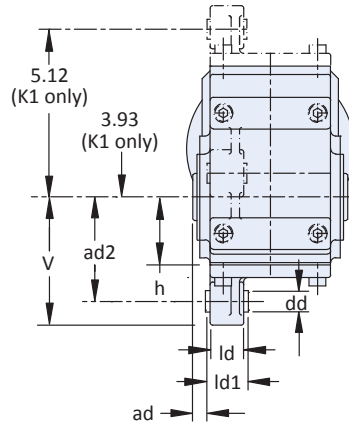
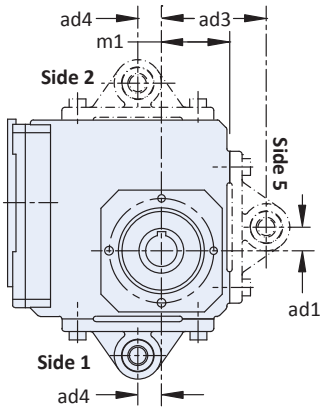

K513AGD thru K1014AGD

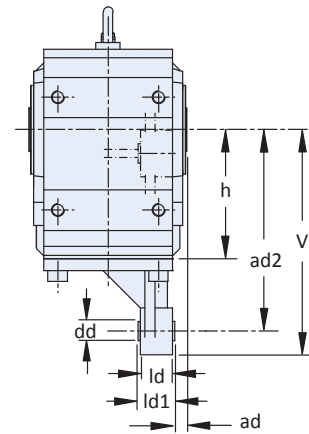
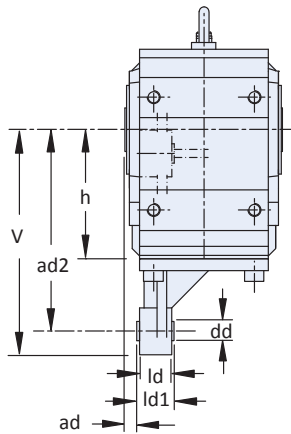
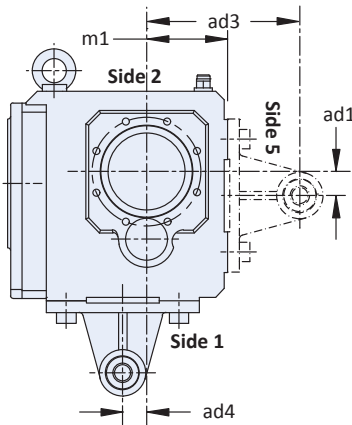
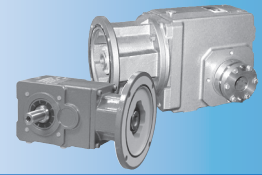

Table 1 “K” Series Dimensions (Inches) — “GD” Torque Arm Bracket

Base Module	ad	ad1	ad2	ad3	ad4	dd	H9	h	ld	ld1	m1	V
K1	0.51	0.59	3.54	3.54	0.59	0.47	+0.017/-0.000	2.36	0.94	1.10	2.36	4.39
K2	0.53	0.89	3.93	3.93	0.89	0.63	+0.017/-0.000	2.56	1.26	1.50	2.56	4.82
K3	0.47	0.98	4.72	4.72	0.98	0.63	+0.017/-0.000	2.95	1.26	1.50	2.95	5.61
K4	0.67	1.08	5.91	5.91	1.08	0.79	+0.020/-0.000	3.54	1.57	1.81	3.54	7.00
K5	0.67	1.18	9.84	7.48	1.18	0.79	+0.020/-0.000	6.30	1.57	1.81	3.93	10.98
K6	0.81	1.18	9.84	7.09	1.18	0.79	+0.020/-0.000	7.48	1.57	1.81	4.72	10.98
K7	0.91	1.38	11.81	8.39	1.38	0.79	+0.020/-0.000	8.35	2.52	2.76	4.92	13.15
K8	1.02	1.77	13.78	9.06	1.77	0.94	+0.020/-0.000	10.43	4.02	4.53	5.71	15.20
K9	1.02	1.77	17.72	12.40	1.77	0.94	+0.020/-0.000	12.40	4.02	4.53	7.09	19.20
K10	0.24	2.17	21.65	15.75	2.36	1.57	+0.024/-0.000	14.76	4.65	4.88	8.86	24.01



Dimensional Data

Torque Arm Mounting Methods

(STOBER can supply the torque arm bracket. The user has to supply the torque arm for Example 1 and 2)

The following mounting methods are recommended for stabilizing the reducer without compromising reducer life.

Example 1: Torque Arm Bracket with Turnbuckle Torque Arm

This method uses a turnbuckle assembly that pivots from the torque arm bracket to mount to an acceptable location.

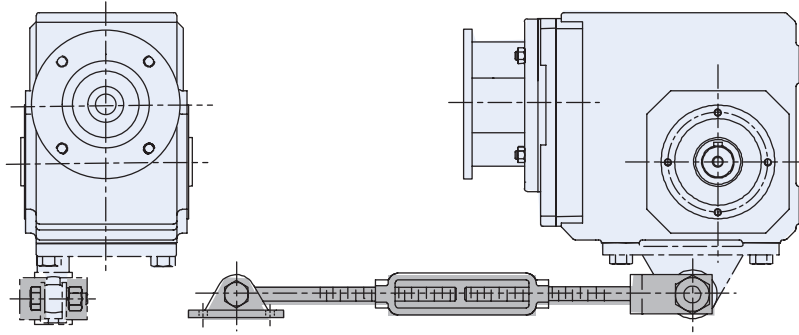

Example 2: Torque Arm Bracket with Fabricated Steel Torque Arm

The torque arm bracket can be ordered with the right angle reducer and the torque arm fabricated from thin steel by the customer to mount in an acceptable location.

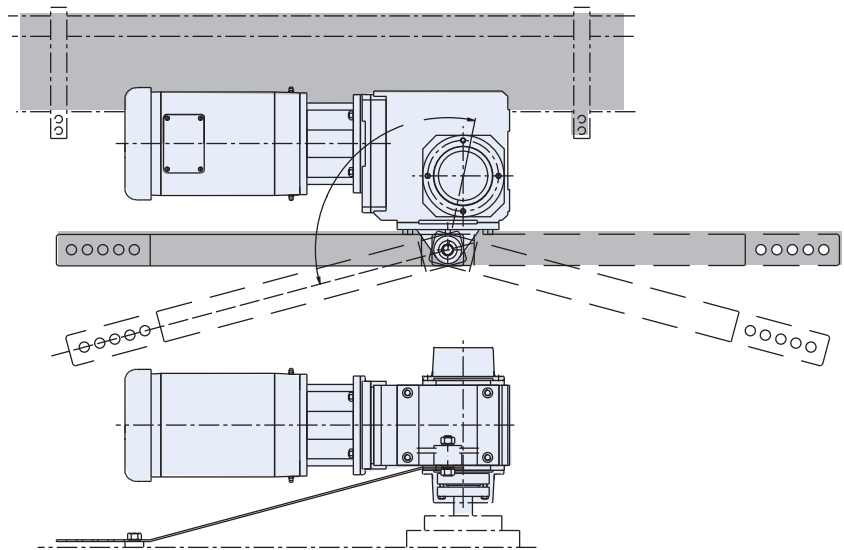

Example 3: Fabricated Torque Arm

Using the mounting holes in the reducer housing, a torque arm can be fabricated to mount directly to the machinery. Notice that the fabrication must be 2 pieces with a slot in each piece to allow the connecting bolt to move in all directions.

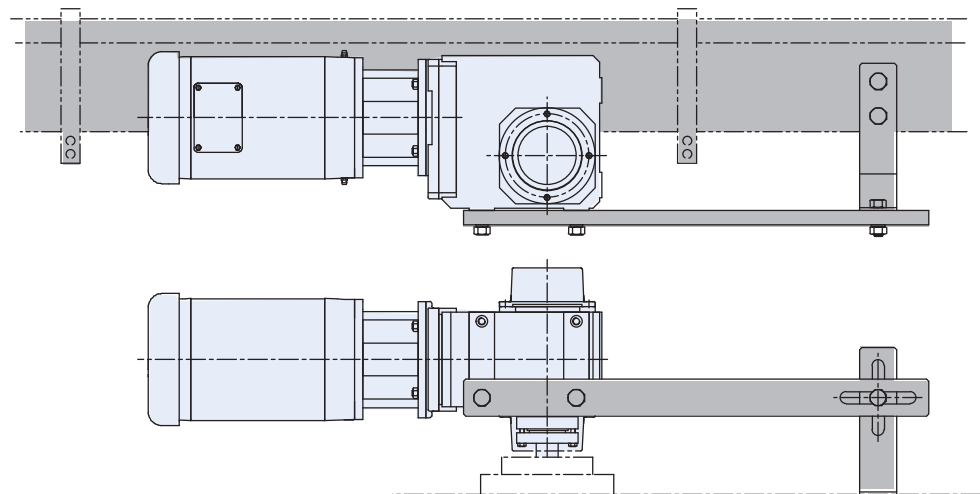

K/KL Series: RIGHT ANGLE — Solid Shaft / Hollow Output

K/KL Series: RIGHT ANGLE — Solid Shaft/Hollow Output

K Series with "A" Hollow Output

"G" Pilot Circle Diameter (PCD) Tapped Holes

* Optional output cover is not a standard part of the A-G configuration and must be ordered separately.

K102AG thru K403AG

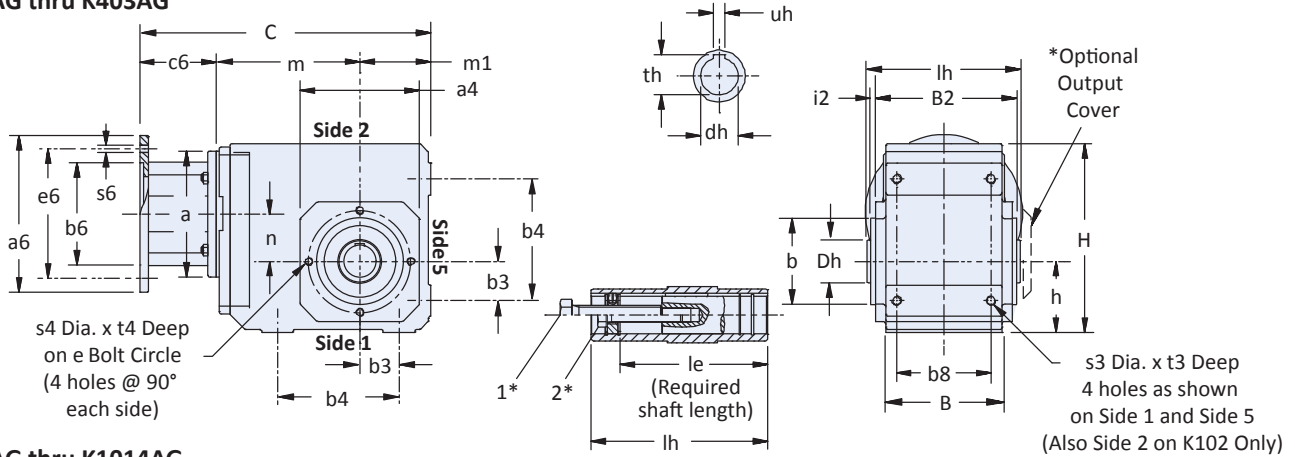

K513AG thru K1014AG

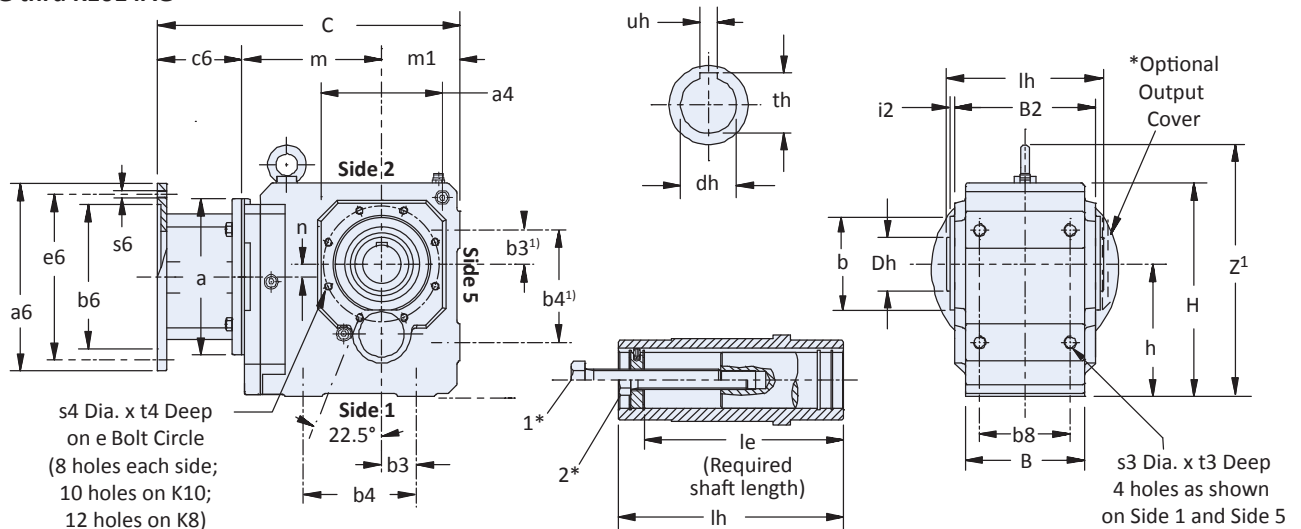

Size K10 Mounting Feet (Dimensions b3 and b4)

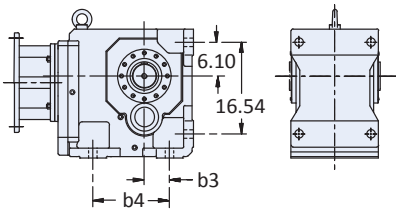

²⁾ Mounting feet are integral on the K10 housing. Note that b3= 6.10 and b4 = 16.54 on Side 5 of the K10. Hole locations are as shown above.

- * 1. Removal Bolt: not supplied. See Installation Guide for details.
- 2. Mounting Bolt: must be smaller than removal bolt.

See hollow output installation instructions for further details

Table 4 Motor Adapter Dimensions (Inches)

Motor Adapter	NEMA C-Flange	a	a6	b6	c6	e6	s6	Wt. lbs
MR140/050	56C	5.51	6.50	4.500	3.31	5.87	0.41	9
MR160/050	56C	6.30	6.50	4.500	3.86	5.87	0.41	16
MR160/140	143/145TC	7.87	9.00	8.500	4.80	7.25	0.55	23
MR200/180	182/184TC	9.84	9.00	8.500	5.31	7.25	0.55	36
MR250/180	213/215TC		9.00	8.500		7.25		
MR300/180	213/215TC		9.00	8.500		7.25		
MR300/210	254/256TC	11.81	9.00	8.500	6.50	7.25	0.57	75
MR300/250	284/286TC		11.13	10.500		9.00		
MR300/280	324/326TC	13.78	13.37	12.500	7.09	11.00	0.70	133
MR350/320	364/365TC							
MR350/360								

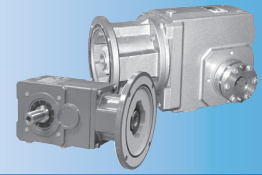

Dimensional Data

Table 1 K Series Unit Dimensions (Inches) — “G” Pilot Circle Diameter (PCD) Tapped Holes

Base Module	a4	b	j6	B2	b3	b4	b8	e	H	h	lh	s3	s4	t3	t4
K1	4.13	2.953	+0.0005/-0.0003	4.17	1.18	3.54	2.76	3.54	6.30	2.36	4.72	M8x1.25	M8x1.25	0.51	0.51
K2	4.57	3.228	+0.0005/-0.0004	5.28	1.38	4.53	3.54	3.94	7.48	2.56	5.83	M10x1.5	M8x1.25	0.63	0.51
K3	5.20	3.740	+0.0005/-0.0004	5.75	1.57	5.12	4.13	4.53	8.39	2.95	6.30	M10x1.5	M8x1.25	0.63	0.55
K4	5.98	4.331	+0.0005/-0.0004	6.81	1.97	6.10	4.72	5.12	9.45	3.54	7.40	M12x1.75	M10x1.5	0.75	0.63
K5	5.71	4.331	+0.0005/-0.0004	7.28	1.57	5.51	4.92	5.12	10.24	6.30	7.87	M16x2.0	M10x1.5	1.02	0.63
K6	7.09	5.512	+0.0006/-0.0004	7.87	1.97	6.30	5.12	6.50	12.20	7.48	8.46	M16x2.0	M10x1.5	1.02	0.63
K7	7.68	6.102	+0.0006/-0.0004	8.90	2.17	7.09	5.71	7.28	13.46	8.35	9.53	M20x2.5	M12x1.75	1.30	0.75
K8	8.90	7.283	+0.0006/-0.0005	11.10	2.95	9.45	7.28	8.46	16.14	10.43	11.81	M24x3.0	M12x1.75	1.50	0.75
K9	11.02	9.055	+0.0006/-0.0005	12.99	3.74	11.02	8.86	10.43	19.49	12.40	13.78	M30x3.5	M16x2.0	1.89	1.02
K10	13.38	9.843	+0.0006/-0.0005	15.60	4.53 ¹⁾	13.78 ¹⁾	12.99	11.81	23.27	14.76	16.14	1.54 ²⁾	M20x2.5	1.77	1.30

¹⁾ Mounting feet are integral on the K10 housing as shown in inset drawing, facing page. Note b3 = 6.10 and b4 = 16.54 on Side 5 of the K10.

²⁾ For size K10, “j” are thru holes, not tapped. See side 5 view on Size K10 Mounting Feet drawing, facing page.

Table 2 K Series Unit Dimensions (Inches) — “G” Pilot Circle Diameter (PCD) Tapped Holes

Base Module	B	Dh	i2	le	m1	z1	Removal Bolt 1
K1	3.54	1.57	0.12	3.86	2.36	—	1/2 – 13
K2	4.53	1.77	0.12	4.78	2.56	—	1/2 – 13
K3	5.12	1.97	0.12	4.92	2.95	—	5/8 – 11
K4	5.83	2.17	0.14	6.18	3.54	—	3/4 – 10
K5	6.30	2.56	0.14	6.46	3.94	12.28	3/4 – 10
K6	6.61	2.76	0.14	7.05	4.72	14.25	3/4 – 10
K7	7.48	3.35	0.14	8.43	4.92	15.87	1 – 8
K8	9.25	3.94	0.16	10.35	5.71	18.54	1 – 8
K9	11.22	4.33	0.20	11.89	7.09	22.24	1 – 8
K10	15.59	5.12	0.28	14.25	8.86	26.77	1-1/4 – 7

Table 3 K Series Unit Dimensions (Inches) — Standard “A” Hollow Bore Output

(see page 82 for all other optional outputs)

Base Module	Stainless Steel			Carbon Steel		
	dh	th	uh	dh	th	uh
K1	1	1.11	1/4	1	1.11	1/4
K2	1-1/4	1.36	1/4	1-3/16	1.31	1/4
K3	1-3/8	1.52	5/16	1-3/8	1.52	5/16
K4	1-1/2	1.67	3/8	1-1/2	1.67	3/8
K5	2	2.13	1/2	2	2.13	1/2
K6	2	2.23	1/2	2	2.23	1/2
K7	—	—	—	2-3/8	2.66	5/8
K8	—	—	—	2-3/4	3.03	5/8
K9	—	—	—	3-1/4	3.59	3/4
K10	—	—	—	4	4.25	1

Table 5 K Series Unit Dimensions (inches) — “MR” Motor Adapter

Base Module	MR140/050			MR160/050 MR160/140			MR200/180			MR250/180 MR250/210			MR300/180 MR300/210 MR300/250 MR300/280			MR350/320 MR350/360			Wt. lbs* [*]
	C	m	n	C	m	n	C	m	n	C	m	n	C	m	n	C	m	n	
K102	10.55	4.88	1.42	11.26	5.04	1.42	—	—	—	—	—	—	—	—	—	—	—	—	31
K202	11.50	5.63	1.81	12.21	5.79	1.81	13.23	5.87	1.81	—	—	—	—	—	—	—	—	—	40
K203	12.96	7.09	1.81	—	—	—	—	—	—	—	—	—	—	—	—	—	—	—	53
K302	12.68	6.42	2.07	13.38	6.57	2.07	14.40	6.65	2.07	—	—	—	—	—	—	—	—	—	67
K303	14.13	7.87	2.07	15.08	8.27	0.63	—	—	—	—	—	—	—	—	—	—	—	—	73
K402	—	—	—	14.76	7.36	2.36	15.74	7.44	2.36	16.41	7.56	2.36	—	—	—	—	—	—	93
K403	15.51	8.66	2.36	16.46	9.06	0.91	—	—	—	—	—	—	—	—	—	—	—	—	100
K513	—	—	—	14.57	6.77	0.59	15.59	6.85	0.59	16.22	6.97	0.59	—	—	—	—	—	—	106
K514	—	—	—	16.26	8.46	0.59	—	—	—	—	—	—	—	—	—	—	—	—	109
K613	—	—	—	16.10	7.52	0.71	17.12	7.60	0.71	17.75	7.72	0.71	19.49	8.27	0.71	—	—	—	170
K614	—	—	—	17.79	9.21	0.71	—	—	—	—	—	—	—	—	—	—	—	—	177
K713	—	—	—	—	—	—	18.42	8.70	0.79	19.05	8.82	0.79	20.75	9.33	0.79	—	—	—	221
K714	—	—	—	19.13	10.35	0.79	20.86	11.14	0.79	—	—	—	—	—	—	—	—	—	234
K813	—	—	—	—	—	—	20.23	9.72	0.94	20.82	9.80	0.94	22.52	10.31	0.94	—	—	—	309
K814	—	—	—	—	—	—	22.64	12.13	0.94	23.62	12.60	0.20	—	—	—	—	—	—	331
K913	—	—	—	—	—	—	—	—	—	23.97	11.57	0.98	25.68	12.09	0.98	27.17	12.99	0.98	508
K914	—	—	—	—	—	—	25.79	13.90	0.98	26.77	14.37	0.98	—	—	—	—	—	—	530
K1013	—	—	—	—	—	—	—	—	—	—	—	—	30.79	15.43	1.10	32.29	16.34	1.10	913
K1014	—	—	—	—	—	—	—	—	—	31.89	17.72	1.10	—	—	—	—	—	—	993

* Weight is base unit only. MR weight must be added separately.

K/KL Series: RIGHT ANGLE — Solid Shaft / Hollow Output

K/KL Series: RIGHT ANGLE — Solid Shaft/Hollow Output

K Series with "A" Hollow Output

Other flange sizes available, see page 122 for details.

"F" Round Flange Housing

K102AF thru K403AF

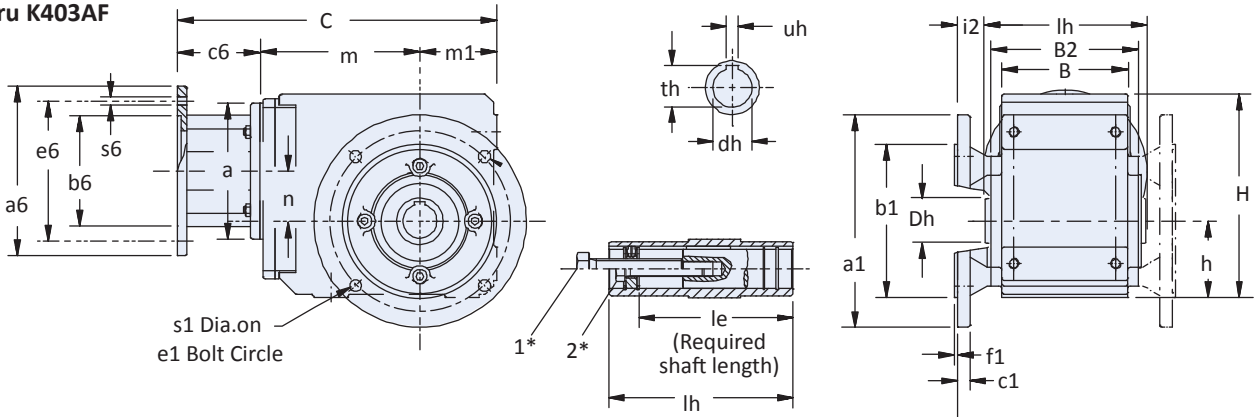

K513AF thru K1014AF

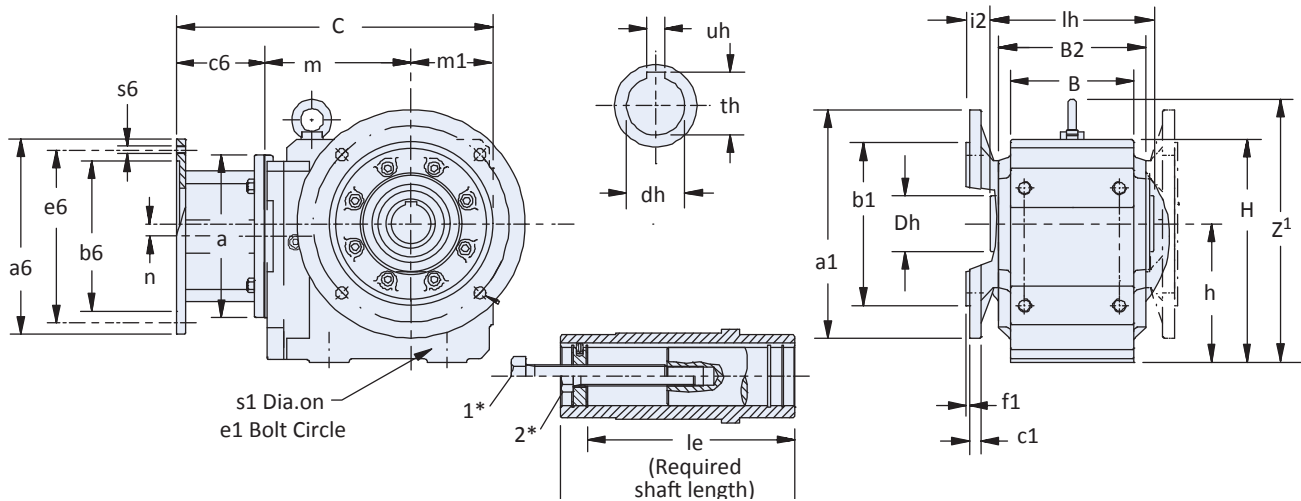

- * 1. Removal Bolt: not supplied. See Installation Guide for details.
- 2. Mounting Bolt: must be smaller than removal bolt.

See hollow output installation instructions for further details

Size K9 and K10 Flange

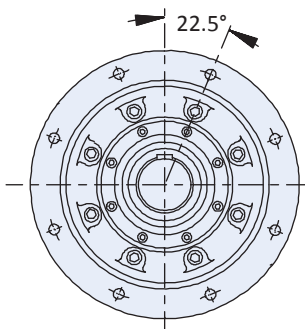

K913 thru K1014 has 8 mounting holes in the output flange located as shown.

Table 3 Motor Adapter Dimensions (Inches)

Motor Adapter	NEMA C-Flange	a	a6	b6	c6	e6	s6	Wt. lbs
MR140/050	56C	5.51	6.50	4.500	3.31	5.87	0.41	9
MR160/050	56C	6.30	6.50	4.500	3.86	5.87	0.41	16
MR160/140	143/145TC	7.87	9.00	8.500	4.80	7.25	0.55	23
MR200/180	182/184TC	9.84	9.00	8.500	5.31	7.25	0.55	36
MR250/180	182/184TC	11.81	9.00	8.500	6.50	7.25	0.57	75
MR250/210	213/215TC		9.00	8.500		7.25		
MR300/210	213/215TC		9.00	8.500		7.25		
MR300/250	254/256TC	13.78	9.00	8.500	7.09	7.25	0.70	133
MR300/280	284/286TC		11.13	10.500		9.00		
MR350/320	324/326TC		13.37	12.500		11.00		
MR350/360	364/365TC							

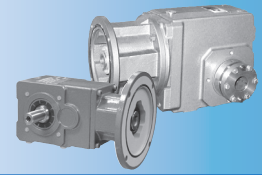

Dimensional Data

Table 1 K Series Unit Dimensions (Inches) — “F” Round Flange Housing

Base Module	a1 ¹⁾	B	b1			B2	c1	Dh	e1	f1	H	h	i2	le	lh	m1	s1	Z ¹	Removal Bolt 1
K1	6.30	3.54	4.331	+0.0005/-0.0004	4.17	0.39	1.57	5.12	0.14	6.30	2.36	1.26	3.86	4.72	2.36	0.35	—	1/2 – 13	
K2	7.87	4.53	5.118	+0.0006/-0.0004	5.28	0.47	1.77	6.50	0.14	7.48	2.56	1.26	4.78	5.83	2.56	0.43	—	1/2 – 13	
K3	7.87	5.12	5.118	+0.0006/-0.0004	5.75	0.55	1.97	6.50	0.14	8.39	2.95	1.50	4.92	6.30	2.95	0.43	—	5/8 – 11	
K4	9.84	5.83	7.087	+0.0006/-0.0004	6.81	0.59	2.17	8.46	0.16	9.45	3.54	1.57	6.18	7.40	3.54	0.55	—	3/4 – 10	
K5	9.84	6.30	7.087	+0.0006/-0.0004	7.28	0.59	2.56	8.46	0.16	10.24	6.30	1.56	6.46	7.87	3.94	0.55	12.28	3/4 – 10	
K6	11.81	6.61	9.055	+0.0006/-0.0005	7.87	0.67	2.76	10.43	0.16	12.20	7.48	1.42	7.05	8.46	4.72	0.55	14.25	3/4 – 10	
K7	13.78	7.48	9.842	+0.000/-0.001	8.90	0.71	3.35	11.81	0.20	13.46	8.35	1.73	8.43	9.53	4.92	0.71	15.87	1 – 8	
K8	15.75	9.25	11.811	+0.000/-0.001	11.10	0.79	3.94	13.78	0.20	16.14	10.43	1.77	10.35	11.81	5.71	0.71	18.54	1 – 8	
K9	17.72	11.22	13.780	+0.000/-0.001	12.99	0.91	4.33	15.75	0.20	19.49	12.40	1.97	11.89	13.78	7.09	0.71	22.24	1 – 8	
K10	21.65	15.75	17.716	+0.000/-0.002	15.60	0.98	5.12	19.69	0.20	23.27	14.76	3.07	14.25	16.14	8.86	0.71	26.77	1-1/4 – 7	

1) See page 122 for other flange sizes. Optional flanges are not available for all sizes.

Table 2 K Series Unit Dimensions (Inches) — Standard “A” Hollow Bore Output (see page 82 for all other optional outputs)

Base Module	Stainless Steel			Carbon Steel		
	dh	th	uh	dh	th	uh
K1	1	1.11	1/4	1	1.11	1/4
K2	1-1/4	1.36	1/4	1-3/16	1.31	1/4
K3	1-3/8	1.52	5/16	1-3/8	1.52	5/16
K4	1-1/2	1.67	3/8	1-1/2	1.67	3/8
K5	2	2.13	1/2	2	2.13	1/2
K6	2	2.23	1/2	2	2.23	1/2
K7	—	—	—	2-3/8	2.66	5/8
K8	—	—	—	2-3/4	3.03	5/8
K9	—	—	—	3-1/4	3.59	3/4
K10	—	—	—	4	4.25	1

Table 4 K Series Unit Dimensions (inches) — “MR” Motor Adapter

Base Module	MR140/050			MR160/050 MR160/140			MR200/180			MR250/180 MR250/210			MR300/180 MR300/210 MR300/250 MR300/280			MR350/320 MR350/360			Wt. lbs* [†]
	C	m	n	C	m	n	C	m	n	C	m	n	C	m	n	C	m	n	
K102	10.55	4.88	1.42	11.26	5.04	1.42	—	—	—	—	—	—	—	—	—	—	—	—	31
K202	11.50	5.63	1.81	12.21	5.79	1.81	13.23	5.87	1.81	—	—	—	—	—	—	—	—	—	40
K203	12.96	7.09	1.81	—	—	—	—	—	—	—	—	—	—	—	—	—	—	—	53
K302	12.68	6.42	2.07	13.38	6.57	2.07	14.40	6.65	2.07	—	—	—	—	—	—	—	—	—	67
K303	14.13	7.87	2.07	15.08	8.27	0.63	—	—	—	—	—	—	—	—	—	—	—	—	73
K402	—	—	—	14.76	7.36	2.36	15.74	7.44	2.36	16.41	7.56	2.36	—	—	—	—	—	—	93
K403	15.51	8.66	2.36	16.46	9.06	0.91	—	—	—	—	—	—	—	—	—	—	—	—	100
K513	—	—	—	14.57	6.77	0.59	15.59	6.85	0.59	16.22	6.97	0.59	—	—	—	—	—	—	106
K514	—	—	—	16.26	8.46	0.59	—	—	—	—	—	—	—	—	—	—	—	—	109
K613	—	—	—	16.10	7.52	0.71	17.12	7.60	0.71	17.75	7.72	0.71	19.49	8.27	0.71	—	—	—	170
K614	—	—	—	17.79	9.21	0.71	—	—	—	—	—	—	—	—	—	—	—	—	177
K713	—	—	—	—	—	—	18.42	8.70	0.79	19.05	8.82	0.79	20.75	9.33	0.79	—	—	—	221
K714	—	—	—	19.13	10.35	0.79	20.86	11.14	0.79	—	—	—	—	—	—	—	—	—	234
K813	—	—	—	—	—	—	20.23	9.72	0.94	20.82	9.80	0.94	22.52	10.31	0.94	—	—	—	309
K814	—	—	—	—	—	—	22.64	12.13	0.94	23.62	12.60	0.20	—	—	—	—	—	—	331
K913	—	—	—	—	—	—	—	—	—	23.97	11.57	0.98	25.68	12.09	0.98	27.17	12.99	0.98	508
K914	—	—	—	—	—	—	25.79	13.90	0.98	26.77	14.37	0.98	—	—	—	—	—	—	530
K1013	—	—	—	—	—	—	—	—	—	—	—	—	30.79	15.43	1.10	32.29	16.34	1.10	913
K1014	—	—	—	—	—	—	—	—	—	31.89	17.72	1.10	—	—	—	—	—	—	993

* Weight is base unit only. MR weight must be added separately.

K/KL Series: RIGHT ANGLE — Solid Shaft / Hollow Output

K/KL Series: RIGHT ANGLE — Solid Shaft/Hollow Output

K Series with "V" Solid Shaft Output

"G" Pilot Circle Diameter (PCD) Tapped Holes

* Optional output cover is not a standard part of the V-G configuration and must be ordered separately. Dimension BC is from Center Side 5 to the outer edge of optional cover.

K102VG thru K403VG

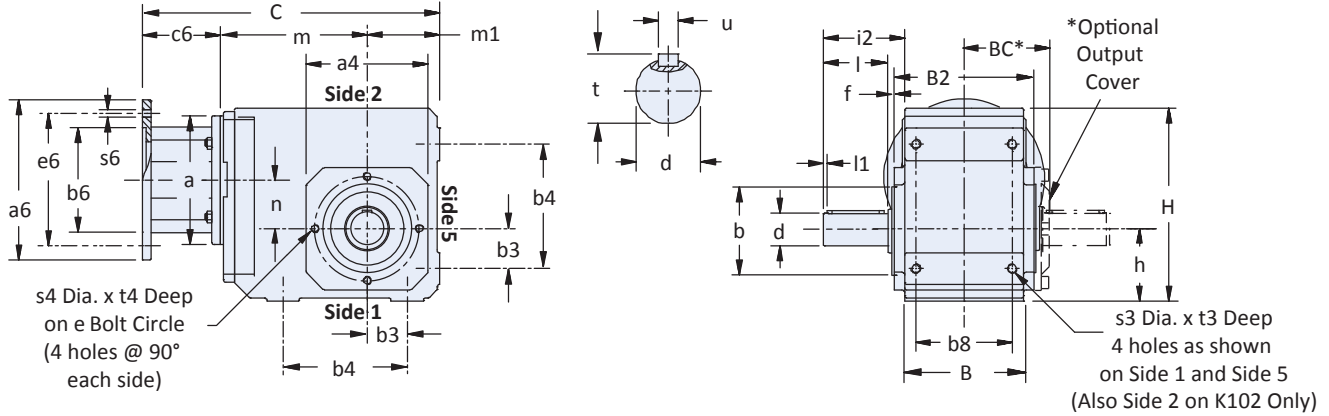

K513VG thru K1014VG

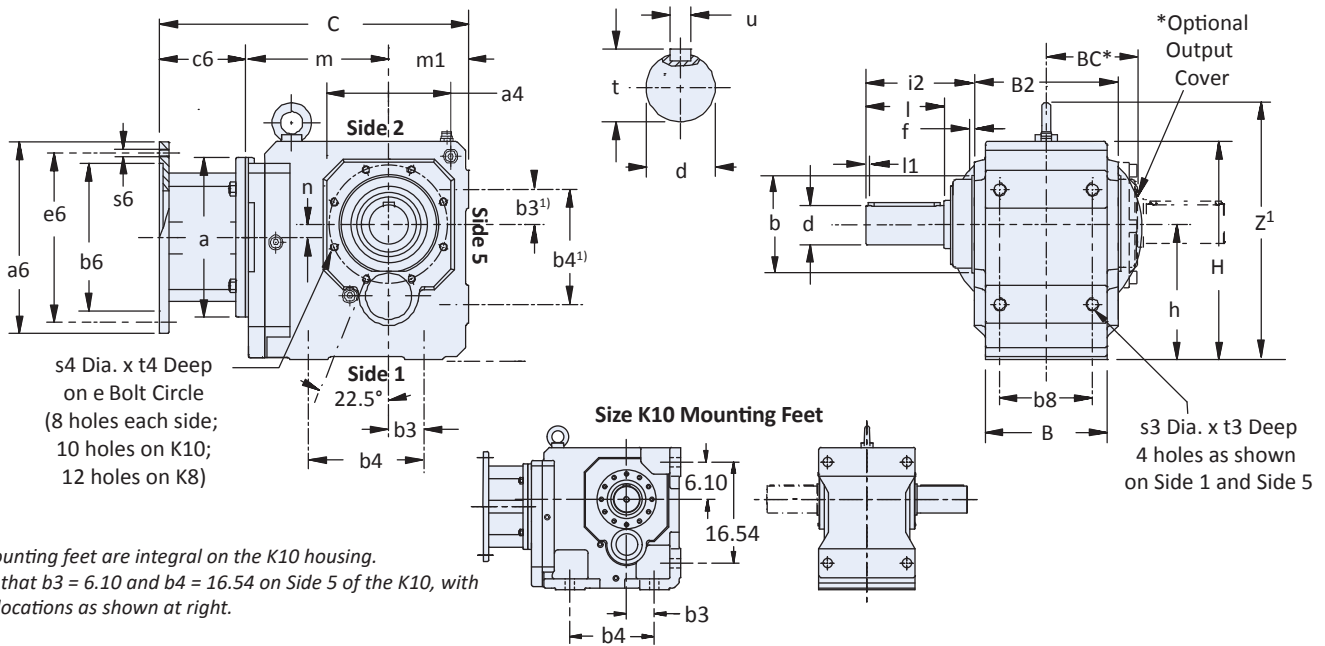

²⁾ Mounting feet are integral on the K10 housing.
Note that $b_3 = 6.10$ and $b_4 = 16.54$ on Side 5 of the K10, with hole locations as shown at right.

Table 3 K Series — "V" Shaft Output (Carbon Steel)

(see page 82 for standard SS, and other optional outputs)

Base Module	Standard Shaft – inches			Optional Shaft – mm		
	d	t	u – Key	d	t	u – Key
K1	1	1.11	1/4x1/4x1-9/16	25k6	28	A8x7x40
K2	1-1/4	1.36	1/4x1/4x1-15/16	30k6	33	A8x7x50
K3	1-1/4	1.36	1/4x1/4x1-15/16	30k6	33	A8x7x50
K4	1-3/8	1.51	5/16x5/16x2-5/16	40k6	43	A12x8x70
K5	1-3/4	1.92	3/8x3/8x3-5/32	45k6	48.5	A14x9x80
K6	1-3/4	1.92	3/8x3/8x3-5/32	50k6	53.5	A14x9x90
K7	2-3/8	2.65	5/8x5/8x3-15/16	60k6	64	A18x11x110
K8	2-7/8	3.21	3/4x3/4x4-5/16	70m6	74.5	A20x12x125
K9	3-5/8	4.01	7/8x7/8x5-1/2	90m6	95	A25x14x140
K10	4-3/8	4.82	1x1x7-1/8	110m6	116	A28x16x180

Table 4 Motor Adapter Dimensions (Inches)

Motor Adapter	NEMA C-Flange	a	a6	b6	c6	e6	s6	Wt. lbs
MR140/050	56C	5.51	6.50	4.500	3.31	5.87	0.41	9
MR160/050	56C	6.30	6.50	4.500	3.86	5.87	0.41	16
MR160/140	143/145TC	7.87	9.00	8.500	4.80	7.25	0.55	23
MR200/180	182/184TC	9.84	9.00	8.500	5.31	7.25	0.55	36
MR250/180	182/184TC		9.00	8.500		7.25		
MR250/210	213/215TC		9.00	8.500	6.50	7.25	0.57	75
MR300/180	182/184TC		9.00	8.500		7.25		
MR300/210	213/215TC	11.81	9.00	8.500		7.25		
MR300/250	254/256TC		9.00	8.500		7.25		
MR300/280	284/286TC		11.13	10.500		9.00		
MR350/320	324/326TC	13.78	13.37	12.500	7.09	11.00	0.70	133
MR350/360	364/365TC							

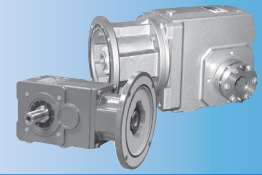

Dimensional Data

Table 1 K Series Unit Dimensions (Inches) — “G” Pilot Circle Diameter (PCD) Tapped Holes

Base Module	a4	BC	B2	b3	b4	b8	e	H	h	l	t3	t4
K1	4.13	2.64	4.17	1.18	3.54	2.76	3.54	6.30	2.36	1.97	0.51	0.51
K2	4.57	3.23	5.28	1.38	4.53	3.54	3.94	7.48	2.56	2.36	0.63	0.51
K3	5.20	3.46	5.75	1.57	5.12	4.13	4.53	8.39	2.95	2.36	0.63	0.55
K4	5.98	4.08	6.81	1.97	6.10	4.72	5.12	9.45	3.54	2.76	0.75	0.63
K5	5.71	4.31	7.28	1.57	5.51	4.92	5.12	10.24	6.30	3.54	1.02	0.63
K6	7.09	4.61	7.87	1.97	6.30	5.12	6.50	12.20	7.48	3.54	1.02	0.63
K7	7.68	5.08	8.90	2.17	7.09	5.71	7.28	13.46	8.35	4.72	1.30	0.75
K8	8.90	6.26	11.10	2.95	9.45	7.28	8.46	16.14	10.43	5.51	1.50	0.75
K9	11.02	7.48	12.99	3.74	11.02	8.86	10.43	19.49	12.40	6.69	1.89	1.02
K10	13.38	9.59	15.60	4.53 ¹⁾	13.78 ¹⁾	12.99	11.81	23.27	14.76	8.27	1.77	1.30

¹⁾ Mounting feet are integral on the K10 housing as shown in Size K10 Mounting Feet drawing, facing page. Note b3 = 6.10 and b4 = 16.54 on Side 5 of the K10.

Table 2 K Series Unit Dimensions (Inches) — “G” Pilot Circle Diameter (PCD) Tapped Holes

Base Module	B	b	j6	f	i2	l1	m1	s3	s4	z ¹
K1	3.54	2.953	+0.0005/-0.0003	0.16	2.32	0.16	2.36	M8 x 1.25	M8 x 1.25	—
K2	4.53	3.228	+0.0005/-0.0004	0.16	2.56	0.16	2.56	M10 x 1.5	M8 x 1.25	—
K3	5.12	3.740	+0.0005/-0.0004	0.16	2.60	0.16	2.95	M10 x 1.5	M8 x 1.25	—
K4	5.83	4.331	+0.0005/-0.0004	0.16	3.39	0.16	3.54	M12 x 1.75	M10 x 1.5	—
K5	6.30	4.331	+0.0005/-0.0004	0.16	5.10	0.16	3.94	M16 x 2.0	M10 x 1.5	12.28
K6	6.61	5.512	+0.0006/-0.0004	0.16	5.35	0.16	4.72	M16 x 2.0	M10 x 1.5	14.25
K7	7.48	6.102	+0.0006/-0.0004	0.18	6.46	0.16	4.92	M20 x 2.5	M12 x 1.75	15.87
K8	9.25	7.283	+0.0006/-0.0005	0.20	7.28	0.20	5.71	M24 x 3.0	M12 x 1.75	18.54
K9	11.22	9.055	+0.0006/-0.0005	0.20	8.66	0.31	7.09	M30 x 3.5	M16 x 2.0	22.24
K10	14.02	9.843	+0.0006/-0.0005	0.28	9.45	0.59	8.86	1.54*	M20 x 2.5	26.77

¹⁾ For size K10, “J” are thru holes, not tapped. See side 5 view on Size K10 Mounting Feet drawing, facing page.

Table 5 K Series Unit Dimensions (inches) — “MR” Motor Adapter

Base Module	MR140/050			MR160/050 MR160/140			MR200/180			MR250/180 MR250/210			MR300/180 MR300/210 MR300/250 MR300/280			MR350/320 MR350/360			Wt. lbs* ¹⁾
	C	m	n	C	m	n	C	m	n	C	m	n	C	m	n	C	m	n	
K102	10.55	4.88	1.42	11.26	5.04	1.42	—	—	—	—	—	—	—	—	—	—	—	—	31
K202	11.50	5.63	1.81	12.21	5.79	1.81	13.23	5.87	1.81	—	—	—	—	—	—	—	—	—	40
K203	12.96	7.09	1.81	—	—	—	—	—	—	—	—	—	—	—	—	—	—	—	53
K302	12.68	6.42	2.07	13.38	6.57	2.07	14.40	6.65	2.07	—	—	—	—	—	—	—	—	—	67
K303	14.13	7.87	2.07	15.08	8.27	0.63	—	—	—	—	—	—	—	—	—	—	—	—	73
K402	—	—	—	14.76	7.36	2.36	15.74	7.44	2.36	16.41	7.56	2.36	—	—	—	—	—	—	93
K403	15.51	8.66	2.36	16.46	9.06	0.91	—	—	—	—	—	—	—	—	—	—	—	—	100
K513	—	—	—	14.57	6.77	0.59	15.59	6.85	0.59	16.22	6.97	0.59	—	—	—	—	—	—	106
K514	—	—	—	16.26	8.46	0.59	—	—	—	—	—	—	—	—	—	—	—	—	109
K613	—	—	—	16.10	7.52	0.71	17.12	7.60	0.71	17.75	7.72	0.71	19.49	8.27	0.71	—	—	—	170
K614	—	—	—	17.79	9.21	0.71	—	—	—	—	—	—	—	—	—	—	—	—	177
K713	—	—	—	—	—	—	18.42	8.70	0.79	19.05	8.82	0.79	20.75	9.33	0.79	—	—	—	221
K714	—	—	—	19.13	10.35	0.79	20.86	11.14	0.79	—	—	—	—	—	—	—	—	—	234
K813	—	—	—	—	—	—	20.23	9.72	0.94	20.82	9.80	0.94	22.52	10.31	0.94	—	—	—	309
K814	—	—	—	—	—	—	22.64	12.13	0.94	23.62	12.60	0.20	—	—	—	—	—	—	331
K913	—	—	—	—	—	—	—	—	—	23.97	11.57	0.98	25.68	12.09	0.98	27.17	12.99	0.98	508
K914	—	—	—	—	—	—	25.79	13.90	0.98	26.77	14.37	0.98	—	—	—	—	—	—	530
K1013	—	—	—	—	—	—	—	—	—	—	—	—	30.79	15.43	1.10	32.29	16.34	1.10	913
K1014	—	—	—	—	—	—	—	—	—	31.89	17.72	1.10	—	—	—	—	—	—	993

* Weight is base unit only. MR weight must be added separately.

K/KL Series: RIGHT ANGLE — Solid Shaft / Hollow Output

K/KL Series: RIGHT ANGLE — Solid Shaft/Hollow Output

K Series with "V" Solid Shaft Output

Other flange sizes available, see page 122 for details.

"F" Round Flange Housing

K102VF thru K403VF

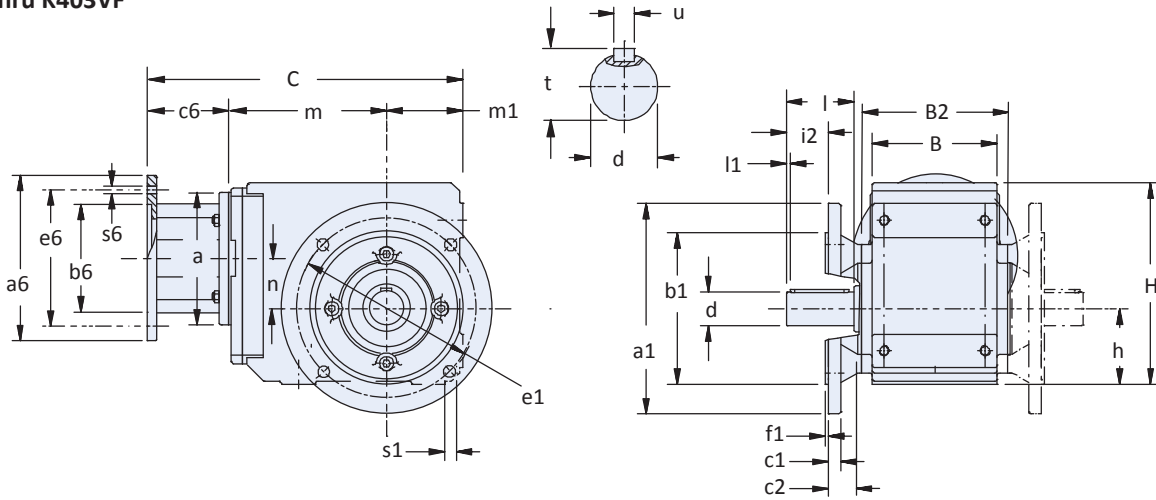

K513VF thru K1014VF

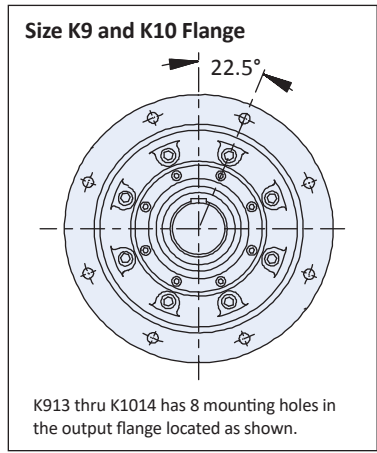
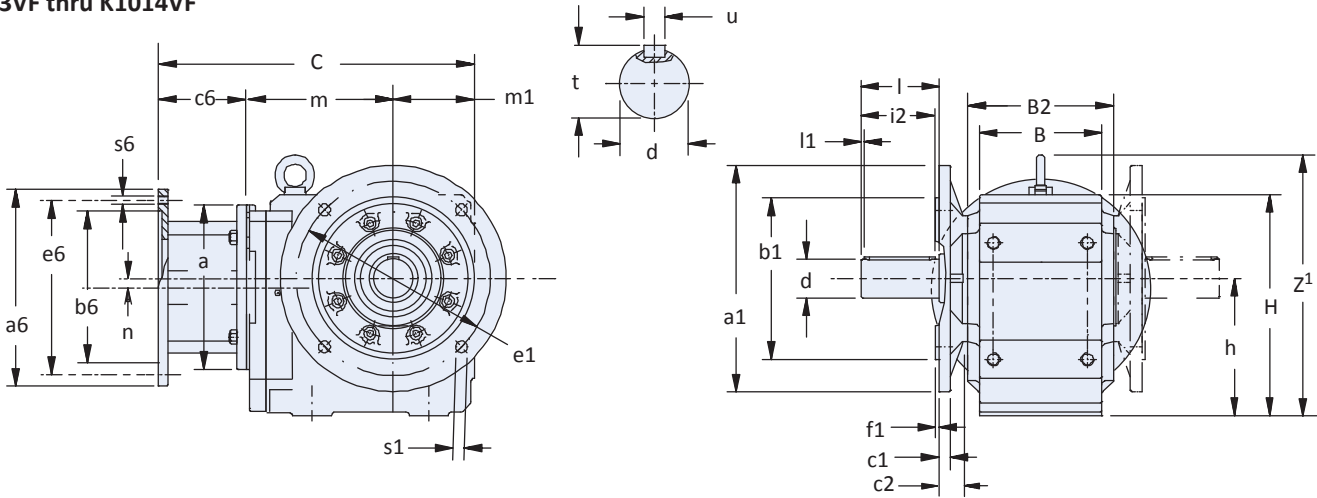
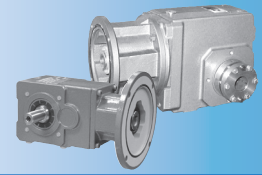

Table 3 Motor Adapter Dimensions (Inches)

Motor Adapter	NEMA C-Flange	a	a6	b6	c6	e6	s6	Wt. lbs
MR140/050	56C	5.51	6.50	4.500	3.31	5.87	0.41	9
MR160/050	56C	6.30	6.50	4.500	3.86	5.87	0.41	16
MR160/140	143/145TC							
MR200/180	182/184TC	7.87	9.00	8.500	4.80	7.25	0.55	23
MR250/180	182/184TC							
MR250/210	213/215TC	9.84	9.00	8.500	5.31	7.25	0.55	36
MR300/180	182/184TC							
MR300/210	213/215TC							
MR300/250	254/256TC	11.81	9.00	8.500	6.50	7.25	0.57	75
MR300/280	284/286TC							
MR350/320	324/326TC	13.78	13.37	12.500	7.09	11.00	0.70	133
MR350/360	364/365TC							



Dimensional Data

Table 1 K Series Unit Dimensions (Inches) — “F” Round Flange Housing

Base Module	a1 ¹⁾	B	b1			B2	c1	c2	e1	f1	H	h	i2	l	l1	m1	s1	z ¹
K1	6.30	3.54	4.331	+0.0005/-0.0004	4.17	0.39	1.26	5.12	0.14	6.30	2.36	1.18	1.97	0.16	2.36	0.35	—	
K2	7.87	4.53	5.118	+0.0006/-0.0004	5.28	0.47	1.26	6.50	0.14	7.48	2.56	1.42	2.36	0.16	2.56	0.43	—	
K3	7.87	5.12	5.118	+0.0006/-0.0004	5.75	0.55	1.50	6.50	0.14	8.39	2.95	1.22	2.36	0.16	2.95	0.43	—	
K4	9.84	5.83	7.087	+0.0006/-0.0005	6.81	0.59	1.57	8.46	0.16	9.45	3.54	1.95	3.14	0.16	3.54	0.55	—	
K5	9.84	6.30	7.087	+0.0006/-0.0005	7.28	0.59	1.56	8.46	0.16	10.24	6.30	3.54	3.54	0.16	3.54	0.55	12.28	
K6	11.81	6.61	9.055	+0.0006/-0.0005	7.87	0.67	1.42	10.43	0.16	12.20	7.48	3.94	3.94	0.16	4.72	0.55	14.25	
K7	13.78	7.48	9.842	+0.000/-0.001	8.90	0.71	1.73	11.81	0.20	13.46	8.35	4.72	4.72	0.16	4.92	0.71	15.87	
K8	15.75	9.25	11.811	+0.000/-0.001	11.10	0.79	1.77	13.78	0.20	16.14	10.43	5.51	5.51	0.20	5.71	0.71	18.54	
K9	17.72	11.22	13.780	+0.000/-0.001	12.99	0.91	1.97	15.75	0.20	19.49	12.40	6.69	6.69	0.31	7.09	0.71	22.24	
K10	21.65	15.75	17.716	+0.000/-0.002	14.02	0.98	3.07	19.69	0.20	23.27	14.76	8.27	8.27	0.59	8.86	0.71	26.77	

1) See page 122 for other flange sizes. Optional flanges are not available for all sizes.

Table 2 K Series Unit Dimensions — “V” Shaft Output (Carbon Steel)

(see page 82 for standard SS, and other optional outputs)

Base Module	Standard Shaft – inches			Optional Shaft – mm		
	d	t	u – Key	d	t	u – Key
K1	1	1.11	1/4 x 1/4 x 1-9/16	25k6	28	A8 x 7 x 40
K2	1-1/4	1.36	1/4 x 1/4 x 1-15/16	30k6	33	A8 x 7 x 50
K3	1-1/4	1.36	1/4 x 1/4 x 1-15/16	30k6	33	A8 x 7 x 50
K4	1-3/8	1.51	5/16 x 5/16 x 2-5/16	40k6	43	A12 x 8 x 70
K5	1-3/4	1.92	3/8 x 3/8 x 3-5/32	45k6	48.5	A14 x 9 x 80
K6	1-3/4	1.92	3/8 x 3/8 x 3-5/32	50k6	53.5	A14 x 9 x 90
K7	2-3/8	2.65	5/8 x 5/8 x 3-15/16	60k6	64	A18 x 11 x 110
K8	2-7/8	3.21	3/4 x 3/4 x 4-5/16	70m6	74.5	A20 x 12 x 125
K9	3-5/8	4.01	7/8 x 7/8 x 5-1/2	90m6	95	A25 x 14 x 140
K10	4-3/8	4.82	1 x 1 x 7-1/8	110m6	116	A28 x 16 x 180

Table 4 K Series Unit Dimensions (inches) — “MR” Motor Adapter

Base Module	MR140/050			MR160/050 MR160/140			MR200/180			MR250/180 MR250/210			MR300/180 MR300/210 MR300/250 MR300/280			MR350/320 MR350/360			Wt. lbs*
	C	m	n	C	m	n	C	m	n	C	m	n	C	m	n	C	m	n	
K102	10.55	4.88	1.42	11.26	5.04	1.42	—	—	—	—	—	—	—	—	—	—	—	—	31
K202	11.50	5.63	1.81	12.21	5.79	1.81	13.23	5.87	1.81	—	—	—	—	—	—	—	—	—	40
K203	12.96	7.09	1.81	—	—	—	—	—	—	—	—	—	—	—	—	—	—	—	53
K302	12.68	6.42	2.07	13.38	6.57	2.07	14.40	6.65	2.07	—	—	—	—	—	—	—	—	—	67
K303	14.13	7.87	2.07	15.08	8.27	0.63	—	—	—	—	—	—	—	—	—	—	—	—	73
K402	—	—	—	14.76	7.36	2.36	15.74	7.44	2.36	16.41	7.56	2.36	—	—	—	—	—	—	93
K403	15.51	8.66	2.36	16.46	9.06	0.91	—	—	—	—	—	—	—	—	—	—	—	—	100
K513	—	—	—	14.57	6.77	0.59	15.59	6.85	0.59	16.22	6.97	0.59	—	—	—	—	—	—	106
K514	—	—	—	16.26	8.46	0.59	—	—	—	—	—	—	—	—	—	—	—	—	109
K613	—	—	—	16.10	7.52	0.71	17.12	7.60	0.71	17.75	7.72	0.71	19.49	8.27	0.71	—	—	—	170
K614	—	—	—	17.79	9.21	0.71	—	—	—	—	—	—	—	—	—	—	—	—	177
K713	—	—	—	—	—	—	18.42	8.70	0.79	19.05	8.82	0.79	20.75	9.33	0.79	—	—	—	221
K714	—	—	—	19.13	10.35	0.79	20.86	11.14	0.79	—	—	—	—	—	—	—	—	—	234
K813	—	—	—	—	—	—	20.23	9.72	0.94	20.82	9.80	0.94	22.52	10.31	0.94	—	—	—	309
K814	—	—	—	—	—	—	22.64	12.13	0.94	23.62	12.60	0.20	—	—	—	—	—	—	331
K913	—	—	—	—	—	—	—	—	—	23.97	11.57	0.98	25.68	12.09	0.98	27.17	12.99	0.98	508
K914	—	—	—	—	—	—	25.79	13.90	0.98	26.77	14.37	0.98	—	—	—	—	—	—	530
K1013	—	—	—	—	—	—	—	—	—	—	—	—	30.79	15.43	1.10	32.29	16.34	1.10	913
K1014	—	—	—	—	—	—	—	—	—	31.89	17.72	1.10	—	—	—	—	—	—	993

* Weight is base unit only. MR weight must be added separately.

K/KL Series: RIGHT ANGLE — Solid Shaft / Hollow Output

K/KL Series: RIGHT ANGLE — Solid Shaft/Hollow Output

K Series with "V" Solid Shaft Output

"NG" Foot Mounting Housing

K102VNG thru K403VNG

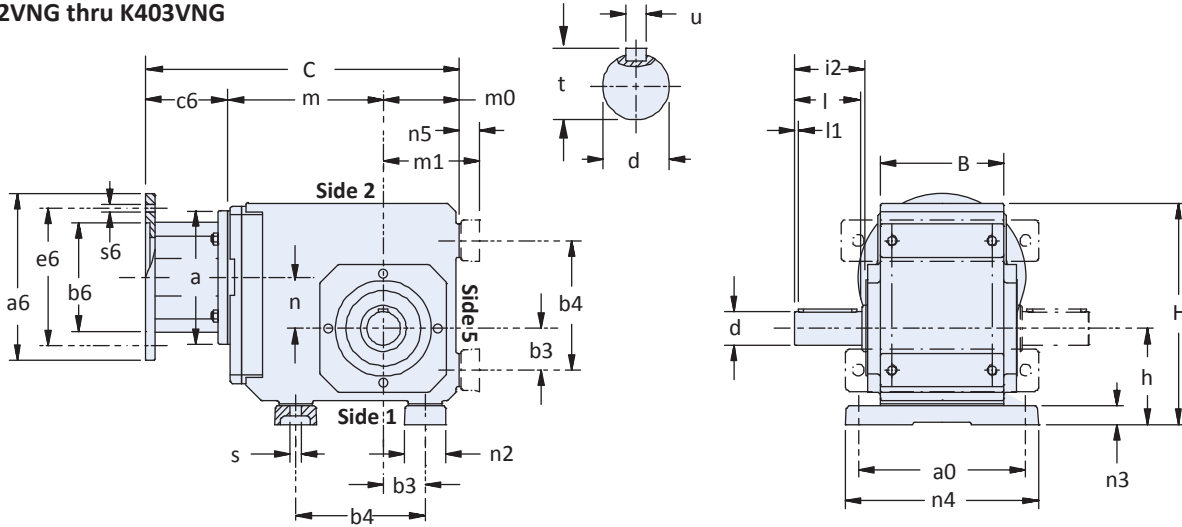

K513VNG thru K1014VNG

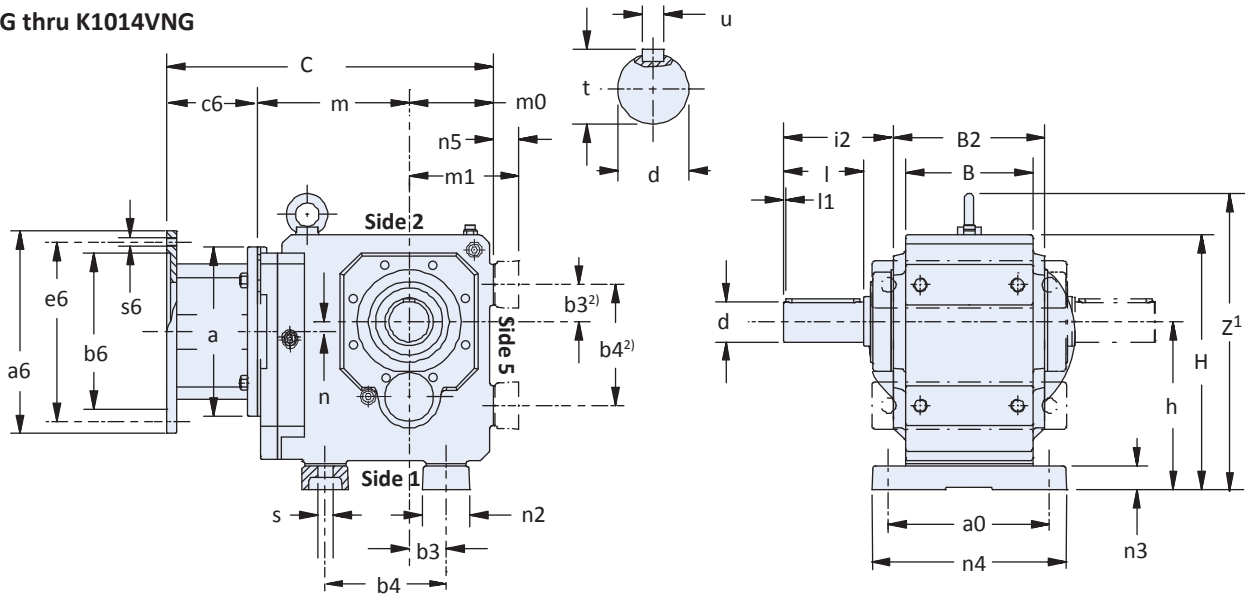
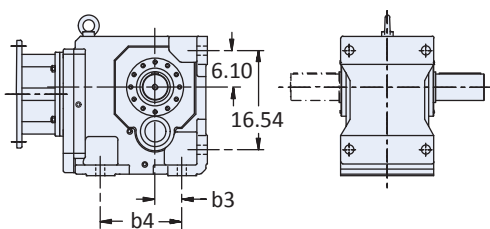

Table 3 Motor Adapter Dimensions (Inches)

Motor Adapter	NEMA C-Flange	a	a6	b6	c6	e6	s6	Wt. lbs
MR140/050	56C	5.51	6.50	4.500	3.31	5.87	0.41	9
MR160/050	56C	6.30	6.50	4.500	3.86	5.87	0.41	16
MR160/140	143/145TC	7.87	9.00	8.500	4.80	7.25	0.55	23
MR200/180	182/184TC	9.84	9.00	8.500	5.31	7.25	0.55	36
MR250/180	182/184TC	11.81	9.00	8.500	6.50	7.25	0.57	75
MR300/210	213/215TC		9.00	8.500		7.25		
MR300/250	254/256TC	11.13	9.00	8.500	7.09	7.25	0.70	133
MR300/280	284/286TC		9.00	8.500		9.00		
MR350/320	324/326TC	13.78	13.37	12.500	7.09	11.00	0.70	133
MR350/360	364/365TC		13.37	12.500		11.00		

Size K10 Mounting Feet (Dimensions F and FA)



²⁾ Mounting feet are integral on the K10 housing. Note that b3 = 6.10 and b4 = 16.54 on Side 5 of the K10. Hole locations are as shown above.

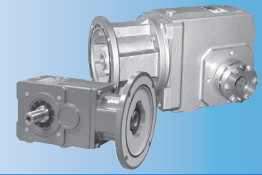

Dimensional Data

Table 1 K Series Unit Dimensions (inches) — “NG” Foot Mounting Housing

Base Module	a0	B	B2	b3	b4	H	h	i2	l	l1	m0	m1	n2	n3	n4	n5	s	z ¹
K1	4.53	3.54	—	1.18	3.54 ¹⁾	6.81	2.95	2.32	1.97	0.16	2.36	2.95	1.18	0.51	5.51	0.59	0.35	—
K2	6.10	4.53	—	1.38	4.53	8.39	3.46	2.56	2.36	0.16	2.56	3.46	1.57	0.79	7.28	0.91	0.43	—
K3	6.69	5.12	—	1.57	5.12	9.29	3.86	2.60	2.36	0.16	2.95	3.86	1.77	0.79	7.87	0.91	0.43	—
K4	7.87	5.83	—	1.97	6.10	10.43	4.53	3.39	2.76	0.16	3.54	4.53	1.97	0.87	9.06	0.98	0.55	—
K5	7.87	6.30	7.28	1.57	5.51	11.42	7.48	5.10	3.54	0.16	3.54	5.12	2.36	1.06	9.45	1.18	0.71	13.46
K6	8.27	6.61	7.87	1.97	6.30	13.39	8.66	5.35	3.54	0.16	4.72	5.91	2.56	1.06	9.84	1.18	0.71	15.43
K7	9.45 ²⁾	7.48	8.90	2.17	7.09	14.96	9.84	6.46	4.72	0.16	4.92	6.42	2.76	1.38	11.42	1.50	0.87	17.36
K8	11.81	9.25	11.10	2.95	9.45	17.91	12.20	7.28	5.51	0.20	5.71	7.48	3.35	1.61	14.17	1.77	1.02	20.31
K9	14.17	11.22	12.99	3.74	11.02	21.46	14.37	8.66	6.69	0.31	7.09	9.06	3.74	1.81	16.93	1.97	1.30	24.21
K10	12.99	15.75	14.02	4.53 ³⁾	13.78 ³⁾	23.27	14.76	9.45	8.27	0.59	—	8.86	4.72	1.77	15.75	1.77	1.54	26.77

¹⁾ Mounting holes are also located on Side 2 of the K1 unit ONLY.

²⁾ For a0 with mounting on side 1 only; a0 when mounting on optional side 5 is 9.49”.

³⁾ Mounting feet are integral on the K10 housing as shown on inset drawing, facing page. Note b3 = 6.10 and b4 = 16.54 on Side 5 of the K10.

Table 2 K Series Unit Dimensions — “V” Shaft Output (Carbon Steel)

(see page 82 for standard SS, and other optional outputs)

Base Module	Standard Shaft – inches			Optional Shaft – mm		
	d	t	u – Key	d	t	u – Key
K1	1	1.11	1/4 x 1/4 x 1-9/16	25k6	28	A8 x 7 x 40
K2	1-1/4	1.36	1/4 x 1/4 x 1-15/16	30k6	33	A8 x 7 x 50
K3	1-1/4	1.36	1/4 x 1/4 x 1-15/16	30k6	33	A8 x 7 x 50
K4	1-3/8	1.51	5/16 x 5/16 x 2-5/16	40k6	43	A12 x 8 x 70
K5	1-3/4	1.92	3/8 x 3/8 x 3-5/32	45k6	48.5	A14 x 9 x 80
K6	1-3/4	1.92	3/8 x 3/8 x 3-5/32	50k6	53.5	A14 x 9 x 90
K7	2-3/8	2.65	5/8 x 5/8 x 3-15/16	60k6	64	A18 x 11 x 110
K8	2-7/8	3.21	3/4 x 3/4 x 4-5/16	70m6	74.5	A20 x 12 x 125
K9	3-5/8	4.01	7/8 x 7/8 x 5-1/2	90m6	95	A25 x 14 x 140
K10	4-3/8	4.82	1 x 1 x 7-1/8	110m6	116	A28 x 16 x 180

Table 4 K Series Unit Dimensions (inches) — “MR” Motor Adapter

Base Module	MR140/050			MR160/050 MR160/140			MR200/180			MR250/180 MR250/210			MR300/180 MR300/210 MR300/250 MR300/280			MR350/320 MR350/360			Wt. lbs* [*]
	C	m	n	C	m	n	C	m	n	C	m	n	C	m	n	C	m	n	
K102	10.55	4.88	1.42	11.26	5.04	1.42	—	—	—	—	—	—	—	—	—	—	—	—	31
K202	11.50	5.63	1.81	12.21	5.79	1.81	13.23	5.87	1.81	—	—	—	—	—	—	—	—	—	40
K203	12.96	7.09	1.81	—	—	—	—	—	—	—	—	—	—	—	—	—	—	—	53
K302	12.68	6.42	2.07	13.38	6.57	2.07	14.40	6.65	2.07	—	—	—	—	—	—	—	—	—	67
K303	14.13	7.87	2.07	15.08	8.27	0.63	—	—	—	—	—	—	—	—	—	—	—	—	73
K402	—	—	—	14.76	7.36	2.36	15.74	7.44	2.36	16.41	7.56	2.36	—	—	—	—	—	—	93
K403	15.51	8.66	2.36	16.46	9.06	0.91	—	—	—	—	—	—	—	—	—	—	—	—	100
K513	—	—	—	14.57	6.77	0.59	15.59	6.85	0.59	16.22	6.97	0.59	—	—	—	—	—	—	106
K514	—	—	—	16.26	8.46	0.59	—	—	—	—	—	—	—	—	—	—	—	—	109
K613	—	—	—	16.10	7.52	0.71	17.12	7.60	0.71	17.75	7.72	0.71	19.49	8.27	0.71	—	—	—	170
K614	—	—	—	17.79	9.21	0.71	—	—	—	—	—	—	—	—	—	—	—	—	177
K713	—	—	—	—	—	—	18.42	8.70	0.79	19.05	8.82	0.79	20.75	9.33	0.79	—	—	—	221
K714	—	—	—	19.13	10.35	0.79	20.86	11.14	0.79	—	—	—	—	—	—	—	—	—	234
K813	—	—	—	—	—	—	20.23	9.72	0.94	20.82	9.80	0.94	22.52	10.31	0.94	—	—	—	309
K814	—	—	—	—	—	—	22.64	12.13	0.94	23.62	12.60	0.20	—	—	—	—	—	—	331
K913	—	—	—	—	—	—	—	—	—	23.97	11.57	0.98	25.68	12.09	0.98	27.17	12.99	0.98	508
K914	—	—	—	—	—	—	25.79	13.90	0.98	26.77	14.37	0.98	—	—	—	—	—	—	530
K1013	—	—	—	—	—	—	—	—	—	—	—	—	30.79	15.43	1.10	32.29	16.34	1.10	913
K1014	—	—	—	—	—	—	—	—	—	31.89	17.72	1.10	—	—	—	—	—	—	993

* Weight is base unit only. MR weight must be added separately.

K/KL Series: RIGHT ANGLE — Solid Shaft / Hollow Output

K/KL Series: RIGHT ANGLE — Solid Shaft/Hollow Output

K Series with SINGLE "W" Wobble Free Bushing Output

"G" Pilot Circle Diameter (PCD) Tapped Holes

K102WG thru K403WG

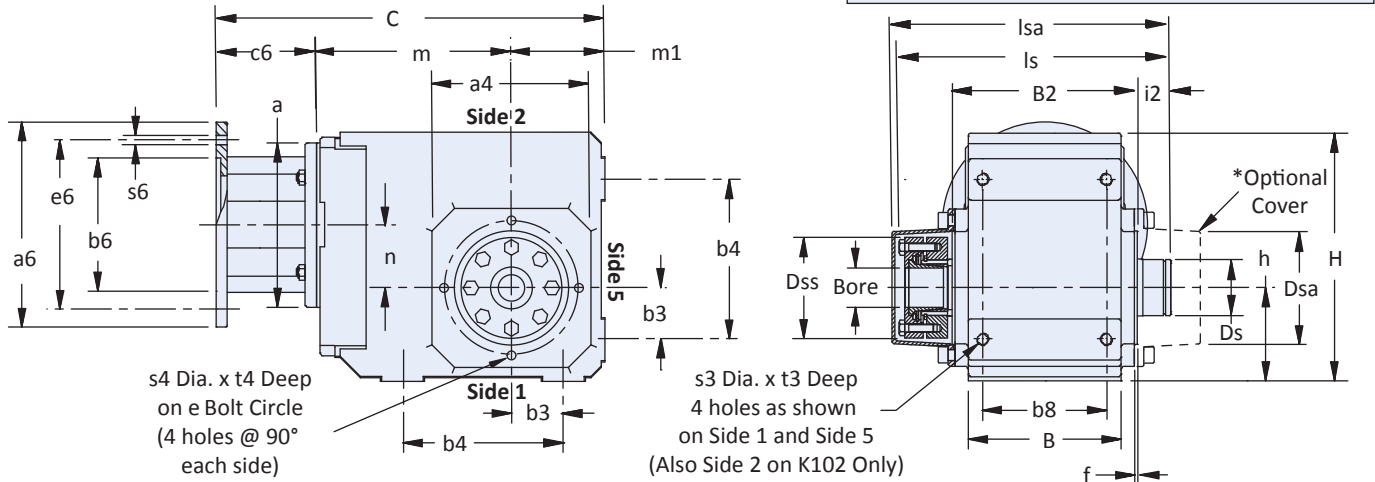

K513WG thru K814WG

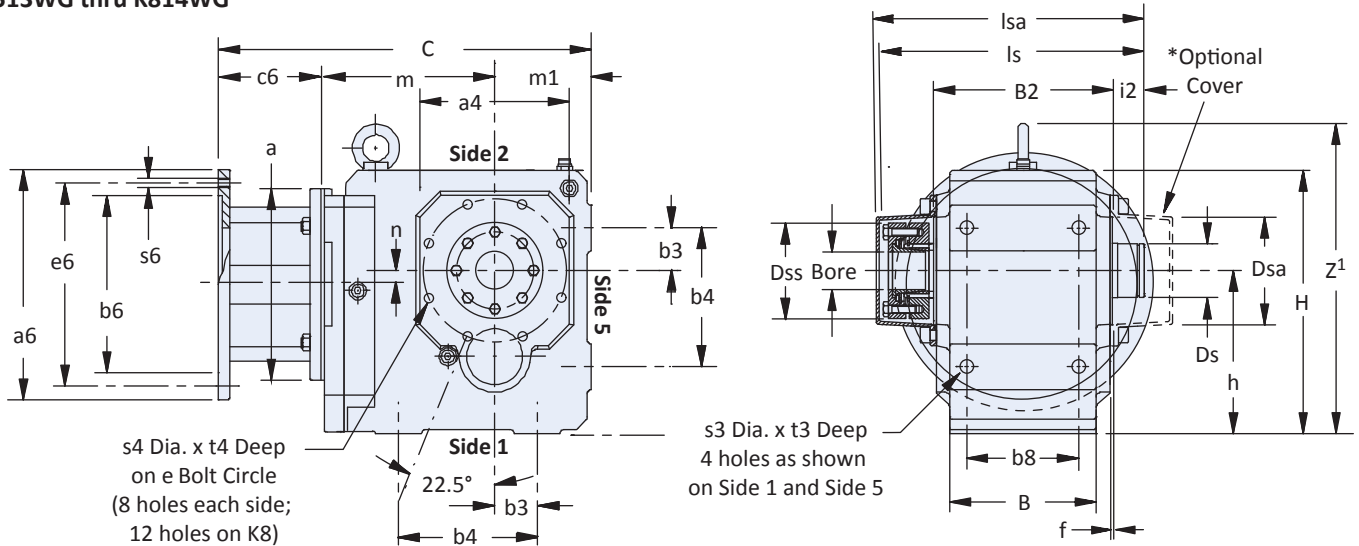

Table 4 Required Output Shaft Length*

Base Module	With Covers	Without Covers
K1	7.97	7.06
K2	9.23	8.32
K3	9.76	8.81
K4	11.42	10.26
K5	11.84	10.80
K6	12.98	11.81
K7	14.82	13.41
K8	17.60	16.20

* Important: A 1/32" x 45° chamfer minimum is recommended for the shaft end. The bushing will accept a shaft with a tolerance of +0.000/-0.005 in.

Table 5 Motor Adapter Dimensions (Inches)

Motor Adapter	NEMA C-Flange	a	a6	b6	c6	e6	s6	Wt. lbs
MR140/050	56C	5.51	6.50	4.500	3.31	5.87	0.41	9
MR160/050	56C	6.30	6.50	4.500	3.86	5.87	0.41	16
MR160/140	143/145TC	7.87	9.00	8.500	4.80	7.25	0.55	23
MR200/180	182/184TC	9.84	9.00	8.500	5.31	7.25	0.55	36
MR250/180	182/184TC	11.81	9.00	8.500	6.50	7.25	0.57	75
MR250/210	213/215TC		9.00	8.500		7.25		
MR300/180	182/184TC		9.00	8.500		7.25		
MR300/210	213/215TC		9.00	8.500		7.25		
MR300/250	254/256TC	11.13	10.500	9.00				
MR300/280	284/286TC							

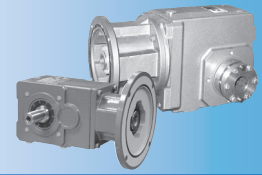

Dimensional Data

K/KL Series: RIGHT ANGLE — Solid Shaft / Hollow Output

Table 1 K Series Unit Dimensions (Inches) – “W” Single Side Wobble Free Bushing

Base Module	a4	B	B2	b3	b4	b8	Ds	Dsa	Dss	e	f
K1	4.13	3.54	4.17	1.18	3.54	2.76	1.54	3.07	2.76	3.54	0.12
K2	4.57	4.53	5.28	1.38	4.53	3.54	1.73	3.46	3.07	3.94	0.12
K3	5.20	5.12	5.75	1.57	5.12	4.13	1.93	3.78	3.31	4.53	0.14
K4	5.98	5.83	6.81	1.97	6.10	4.72	2.13	4.33	3.82	5.12	0.14
K5	5.71	6.30	7.28	1.57	5.51	4.92	2.56	4.53	4.13	5.12	0.14
K6	7.09	6.61	7.87	1.97	6.30	5.12	2.91	5.00	4.65	6.50	0.14
K7	7.68	7.48	8.90	2.17	7.09	5.71	3.35	5.75	5.43	7.28	0.14
K8	8.90	9.25	11.10	2.95	9.45	7.28	3.94	6.95	6.22	8.46	0.16

Table 2 K Series Unit Dimensions (Inches) – “W” Single Side Wobble Free Bushing

Base Module	H	h	i2	ls	lsa	m1	s3	s4	t3	t4	z ¹
K1	6.30	2.36	0.95	6.97	7.05	2.36	M8 x 1.25	M8 x 1.25	0.51	0.51	—
K2	7.48	2.57	1.02	8.23	8.46	2.56	M10 x 1.5	M8 x 1.25	0.63	0.51	—
K3	8.39	2.95	1.02	8.72	8.99	2.95	M10 x 1.5	M8 x 1.25	0.63	0.55	—
K4	9.45	3.54	1.14	10.22	10.49	3.54	M12 x 1.75	M10 x 1.5	0.75	0.63	—
K5	10.24	6.30	1.18	10.77	11.00	3.94	M16 x 2.0	M10 x 1.5	1.02	0.63	12.28
K6	12.20	7.48	1.38	11.46	11.73	4.72	M16 x 2.0	M10 x 1.5	1.02	0.63	14.25
K7	13.46	8.35	1.61	14.52	14.07	4.92	M20 x 2.5	M12 x 1.75	1.30	0.75	15.87
K8	16.14	10.43	2.03	16.59	16.92	5.71	M24 x 3.0	M12 x 1.75	1.50	0.75	18.54

Table 3 “WF” Single Side Bushings Stock Bore Sizes — Stainless Steel

NOTE: Single side bushing kits include 1 each of the pressure and locking ring, tapered cone, support ring, and all hardware to mount the kit into the MGS reducer. The WF1 bushing does not use a tapered cone. Covers are optional.

Base Module	Imperial – Inches															Metric – mm		
	1	1-3/16	1-1/4	1-3/8	1-7/16	1-1/2	1-5/8	1-11/16	1-3/4	1-7/8	1-15/16	2	2-3/16	2-3/8	2-7/16	2-3/4	40	
K1	WF1-100	—	—	—	—	—	—	—	—	—	—	—	—	—	—	—	—	—
K2	WFK2-100	WFK2-103	WFK2-104	—	—	—	—	—	—	—	—	—	—	—	—	—	—	—
K3	WF3-100	WF3-103	WF3-104	WF3-106	WF3-107	WF3-108*	—	—	—	—	—	—	—	—	—	—	—	—
K4	—	—	WF4-104	—	WF4-107	WF4-108	—	—	—	—	—	—	—	—	—	—	—	WF4-40
K5	—	—	—	—	WF5-107	WF5-108	—	—	—	—	WF5-115	WF5-200	—	—	—	—	—	WF5-40
K6	—	—	—	—	WF6-107	WF6-108	—	—	—	—	WF6-115	WF6-200	WF6-203	—	—	—	—	—
K7	—	—	—	—	—	—	—	—	—	—	WF7-115	WF7-200	—	WF7-206	—	—	—	—
K8	—	—	—	—	—	—	—	—	—	—	—	—	WF8-203	WF8-206	WF8-207	WF8-212	—	—

*Base module size K3 is also available with a carbon steel single side 1-1/2” bushing PN SWF3-108

Table 6 K Series Unit Dimensions (inches) — “MR” Motor Adapter

Base Module	MR140/050			MR160/050 MR160/140			MR200/180			MR250/180 MR250/210			MR300/180 MR300/210 MR300/250 MR300/280			MR350/320 MR350/360			Wt. lbs*
	C	m	n	C	m	n	C	m	n	C	m	n	C	m	n	C	m	n	
K102	10.55	4.88	1.42	11.26	5.04	1.42	—	—	—	—	—	—	—	—	—	—	—	—	31
K202	11.50	5.63	1.81	12.21	5.79	1.81	13.23	5.87	1.81	—	—	—	—	—	—	—	—	—	40
K203	12.96	7.09	1.81	—	—	—	—	—	—	—	—	—	—	—	—	—	—	—	53
K302	12.68	6.42	2.07	13.38	6.57	2.07	14.40	6.65	2.07	—	—	—	—	—	—	—	—	—	67
K303	14.13	7.87	2.07	15.08	8.27	0.63	—	—	—	—	—	—	—	—	—	—	—	—	73
K402	—	—	—	14.76	7.36	2.36	15.74	7.44	2.36	16.41	7.56	2.36	—	—	—	—	—	—	93
K403	15.51	8.66	2.36	16.46	9.06	0.91	—	—	—	—	—	—	—	—	—	—	—	—	100
K513	—	—	—	14.57	6.77	0.59	15.59	6.85	0.59	16.22	6.97	0.59	—	—	—	—	—	—	106
K514	—	—	—	16.26	8.46	0.59	—	—	—	—	—	—	—	—	—	—	—	—	109
K613	—	—	—	16.10	7.52	0.71	17.12	7.60	0.71	17.75	7.72	0.71	19.49	8.27	0.71	—	—	—	170
K614	—	—	—	17.79	9.21	0.71	—	—	—	—	—	—	—	—	—	—	—	—	177
K713	—	—	—	—	—	—	18.42	8.70	0.79	19.05	8.82	0.79	20.75	9.33	0.79	—	—	—	221
K714	—	—	—	19.13	10.35	0.79	20.86	11.14	0.79	—	—	—	—	—	—	—	—	—	234
K813	—	—	—	—	—	—	20.23	9.72	0.94	20.82	9.80	0.94	22.52	10.31	0.94	—	—	—	309
K814	—	—	—	—	—	—	22.64	12.13	0.94	23.62	12.60	0.20	—	—	—	—	—	—	331

* Weight is base unit only. MR weight must be added separately.

K/KL Series: RIGHT ANGLE — Solid Shaft/Hollow Output

K Series with DOUBLE "W" Wobble Free Bushing Output

"G" Pilot Circle Diameter (PCD) Tapped Holes

K102WG thru K403WG

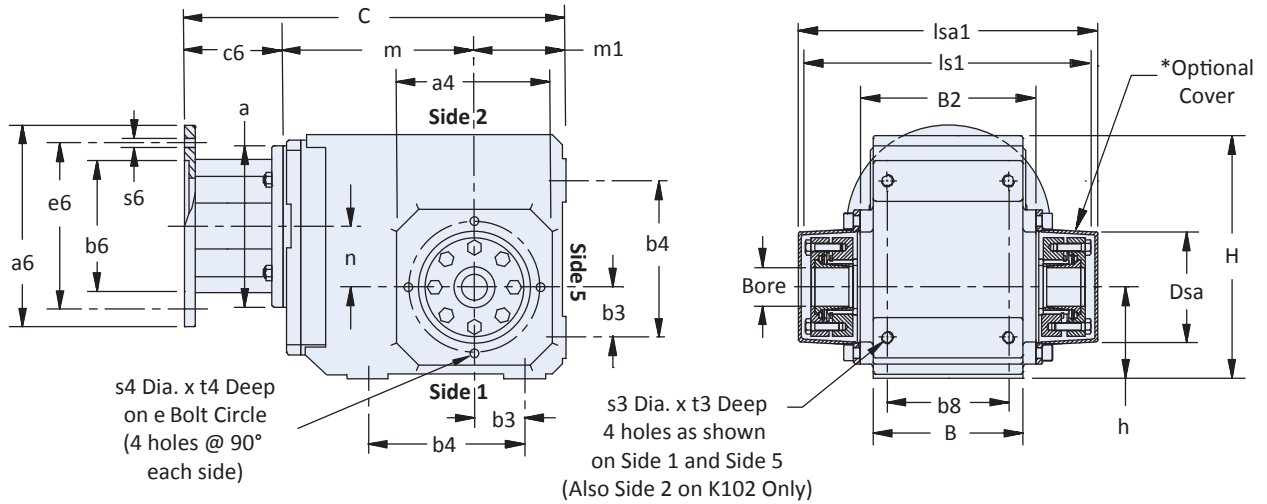

K513WG thru K814WG

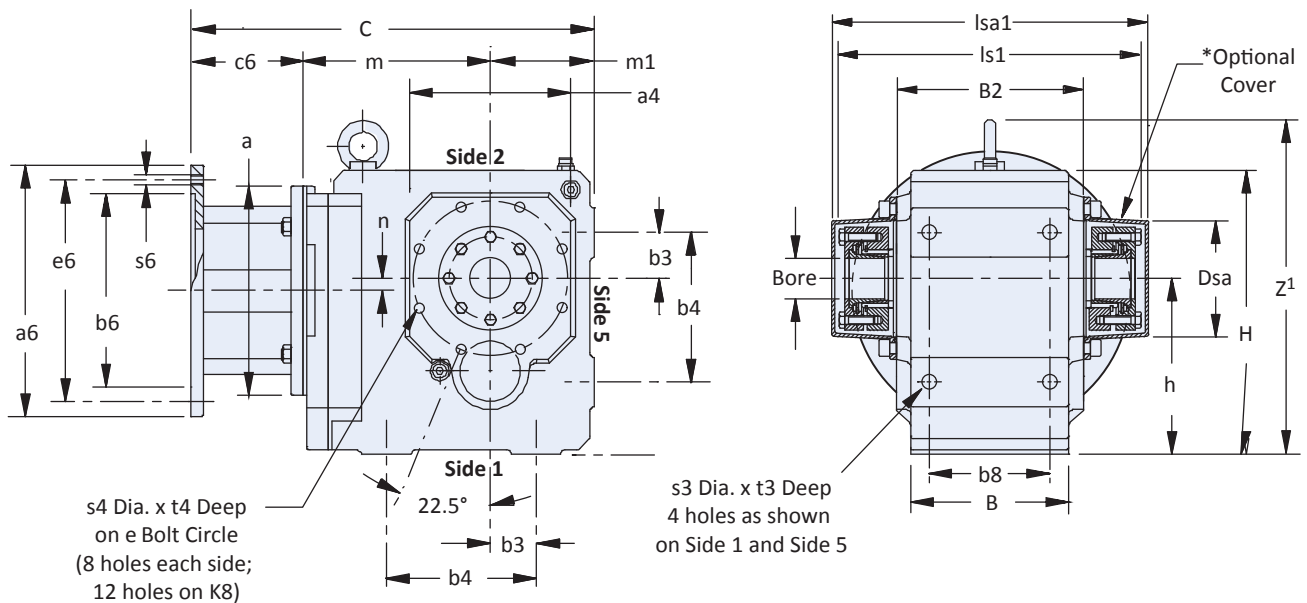

Table 4 Required Output Shaft Length*

Base Module	With Covers	Without Covers
K1	7.97	7.73
K2	9.23	8.99
K3	9.76	9.50
K4	11.42	11.11
K5	11.89	11.61
K6	12.99	12.75
K7	14.83	14.33
K8	17.60	17.29

* Important: A 1/32" x 45° chamfer minimum is recommended for the shaft end. The bushing will accept a shaft with a tolerance of +0.000/-0.005 in.

Table 5 Motor Adapter Dimensions (Inches)

Motor Adapter	NEMA C-Flange	a	a6	b6	c6	e6	s6	Wt. lbs
MR140/050	56C	5.51	6.50	4.500	3.31	5.87	0.41	9
MR160/050	56C	6.30	6.50	4.500	3.86	5.87	0.41	16
MR160/140	143/145TC	7.87	9.00	8.500	4.80	7.25	0.55	23
MR200/180	182/184TC	9.84	9.00	8.500	5.31	7.25	0.55	36
MR250/180	182/184TC	11.81	9.00	8.500	6.50	7.25	0.57	75
MR250/210	213/215TC		9.00	8.500		7.25		
MR300/180	182/184TC		9.00	8.500		7.25		
MR300/210	213/215TC	11.13	10.500	9.00				
MR300/250	254/256TC							
MR300/280	284/286TC							

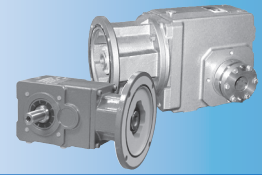

Dimensional Data

K/KL Series: RIGHT ANGLE — Solid Shaft / Hollow Output

Table 1 K Series Unit Dimensions (Inches) – “W” Double Wobble Free Bushing

Base Module	a4	B	B2	b3	b4	b8	Dsa	e	H	h
K1	4.13	3.54	4.17	1.18	3.54	2.76	3.07	3.54	6.30	2.36
K2	4.57	4.53	5.28	1.38	4.53	3.54	3.46	3.94	7.48	2.56
K3	5.20	5.12	5.75	1.57	5.12	4.13	3.78	4.53	8.39	2.95
K4	5.98	5.83	6.81	1.97	6.10	4.72	4.33	5.12	9.45	3.54
K5	5.71	6.30	7.28	1.57	5.51	4.92	4.54	5.12	10.24	6.30
K6	7.09	6.61	7.87	1.97	6.30	5.12	5.00	6.50	12.20	7.48
K7	7.68	7.48	8.90	2.17	7.09	5.71	5.75	7.28	13.46	8.35
K8	8.90	9.25	11.10	2.95	9.45	7.28	6.95	8.46	16.14	10.43

Table 2 K Series Unit Dimensions (Inches) – “W” Double Wobble Free Bushing

Base Module	ls1	lsa1	L	m1	s3	s4	t3	t4	z ¹
K1	7.64	7.80	3.66	2.36	M8 x 1.25	M8 x 1.25	0.51	0.51	—
K2	8.90	9.36	4.26	2.56	M10 x 1.5	M8 x 1.25	0.63	0.51	—
K3	9.41	9.95	4.54	2.95	M10 x 1.5	M8 x 1.25	0.63	0.55	—
K4	11.06	11.60	5.33	3.54	M12 x 1.75	M10 x 1.5	0.75	0.63	—
K5	11.63	12.09	5.61	3.94	M16 x 2.0	M10 x 1.5	1.02	0.63	12.28
K6	12.68	13.22	6.10	4.72	M16 x 2.0	M10 x 1.5	1.02	0.63	14.25
K7	15.06	15.36	7.29	4.92	M20 x 2.5	M12 x 1.75	1.30	0.75	15.87
K8	18.02	18.68	8.70	5.71	M24 x 3.0	M12 x 1.75	1.50	0.75	18.54

Table 3 “WFB” Double Side Bushings Stock Bore Sizes — Stainless Steel

NOTE: A double side bushing kit includes 2 each of a pressure ring and clamp ring, flanged and tapered cone, and all hardware to mount the kit into the reducer. The WFB1 does not use a tapered cone. All double bushing kits include covers.

Base Module	Imperial – Inches															Metric – mm		
	1	1-3/16	1-1/4	1-3/8	1-7/16	1-1/2	1-5/8	1-11/16	1-3/4	1-7/8	1-15/16	2	2-3/16	2-3/8	2-7/16		2-3/4	40
K1	WFB1-100	—	—	—	—	—	—	—	—	—	—	—	—	—	—	—	—	—
K2	WFBK2-100	WFBK2-103	WFBK2-104	—	—	—	—	—	—	—	—	—	—	—	—	—	—	—
K3	WFB3-100	WFB3-103	WFB3-104	WFB3-106	WFB3-107	WFB3-108*	—	—	—	—	—	—	—	—	—	—	—	—
K4	—	—	WFB4-104	—	WFB4-107	WFB4-108	—	—	—	—	—	—	—	—	—	—	—	WFB4-40
K5	—	—	—	—	WFB5-107	WFB5-108	—	—	—	—	WFB5-115	WFB5-200	—	—	—	—	—	WFB5-40
K6	—	—	—	—	WFB6-107	WFB6-108	—	—	—	—	WFB6-115	WFB6-200	WFB6-203	—	—	—	—	
K7	—	—	—	—	—	—	—	—	—	—	WFB7-115	WFB7-200	—	WFB7-206	—	—	—	
K8	—	—	—	—	—	—	—	—	—	—	—	—	WFB8-203	WFB8-206	WFB8-207	WFB8-212	—	

*Base module size K3 is also available with a carbon steel double side 1-1/2” bushing PN SWF3C-108

Table 6 K Series Unit Dimensions (inches) — “MR” Motor Adapter

Base Module	MR140/050			MR160/050 MR160/140			MR200/180			MR250/180 MR250/210			MR300/180 MR300/210 MR300/250 MR300/280			MR350/320 MR350/360			Wt. lbs* [*]
	C	m	n	C	m	n	C	m	n	C	m	n	C	m	n	C	m	n	
K102	10.55	4.88	1.42	11.26	5.04	1.42	—	—	—	—	—	—	—	—	—	—	—	—	31
K202	11.50	5.63	1.81	12.21	5.79	1.81	13.23	5.87	1.81	—	—	—	—	—	—	—	—	—	40
K203	12.96	7.09	1.81	—	—	—	—	—	—	—	—	—	—	—	—	—	—	—	53
K302	12.68	6.42	2.07	13.38	6.57	2.07	14.40	6.65	2.07	—	—	—	—	—	—	—	—	—	67
K303	14.13	7.87	2.07	15.08	8.27	0.63	—	—	—	—	—	—	—	—	—	—	—	—	73
K402	—	—	—	14.76	7.36	2.36	15.74	7.44	2.36	16.41	7.56	2.36	—	—	—	—	—	—	93
K403	15.51	8.66	2.36	16.46	9.06	0.91	—	—	—	—	—	—	—	—	—	—	—	—	100
K513	—	—	—	14.57	6.77	0.59	15.59	6.85	0.59	16.22	6.97	0.59	—	—	—	—	—	—	106
K514	—	—	—	16.26	8.46	0.59	—	—	—	—	—	—	—	—	—	—	—	—	109
K613	—	—	—	16.10	7.52	0.71	17.12	7.60	0.71	17.75	7.72	0.71	19.49	8.27	0.71	—	—	—	170
K614	—	—	—	17.79	9.21	0.71	—	—	—	—	—	—	—	—	—	—	—	—	177
K713	—	—	—	—	—	—	18.42	8.70	0.79	19.05	8.82	0.79	20.75	9.33	0.79	—	—	—	221
K714	—	—	—	19.13	10.35	0.79	20.86	11.14	0.79	—	—	—	—	—	—	—	—	—	234
K813	—	—	—	—	—	—	20.23	9.72	0.94	20.82	9.80	0.94	22.52	10.31	0.94	—	—	—	309
K814	—	—	—	—	—	—	22.64	12.13	0.94	23.62	12.60	0.20	—	—	—	—	—	—	331

* Weight is base unit only. MR weight must be added separately.

K/KL Series: RIGHT ANGLE — Solid Shaft/Hollow Output

Optional “F” Round Flange Housing

“AF” Hollow Output with Flange Housing

“VF” Shaft Output with Flange Housing

AF units shown.

See page 110 for complete AF dimensions

See page 114 for complete VF dimensions

K102_F thru K403_F

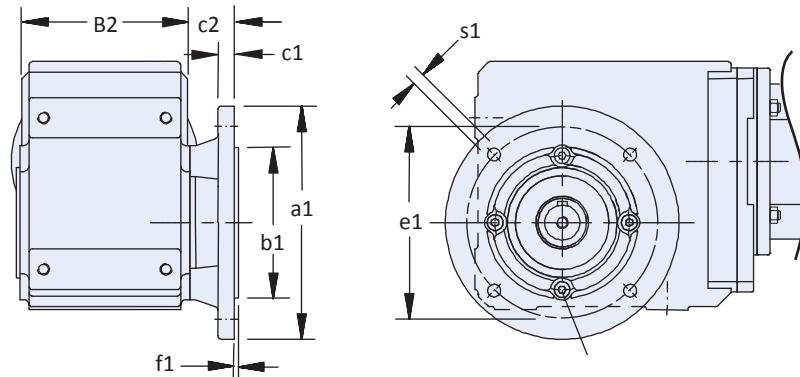

K513_F thru K814_F

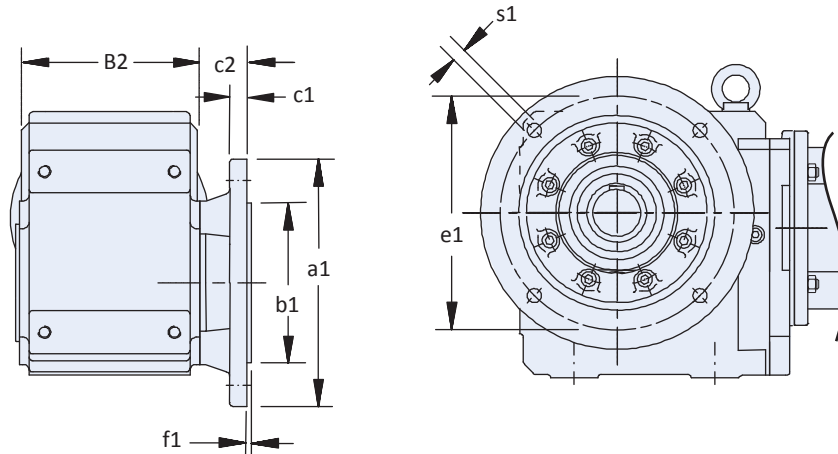

K913_F thru K1014_F

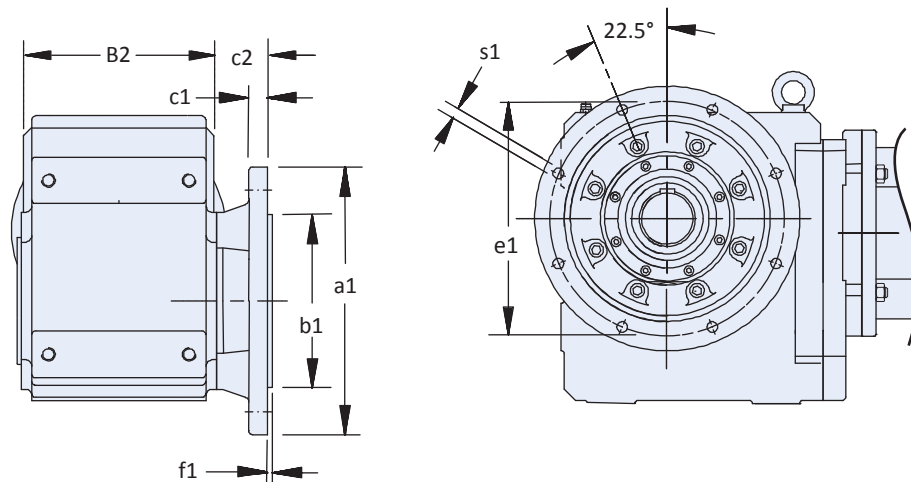

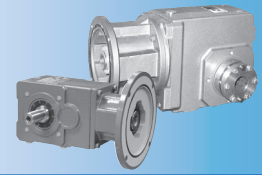

Dimensional Data

Table 1 Flange Dimensions (Inches) – Standard and Optional

Base Module	Flange Size	a1	b1		B2	c1	c2	e1	f1	s1
K1	140	5.512	3.740	+0.001/-0.0004	4.17	0.39	1.26	4.53	0.12	0.35
	160*	6.300	4.331	+0.001/-0.0004				5.12		
K2	160	6.300	4.331	+0.001/-0.0004	5.28	0.47	1.26	5.12	0.14	0.35
	200*	7.874	5.118	+0.001/-0.0004				6.50		0.43
K3	160	6.300	4.331	+0.001/-0.0004	5.75	0.55	1.50	5.12	0.14	0.35
	200*	7.874	5.118	+0.001/-0.0004				6.50		0.43
	250	9.843	7.087	+0.001/-0.0004				8.46		0.16
K4	250*	9.843	7.087	+0.001/-0.0004	6.81	0.59	1.57	8.46	0.16	0.55
K5	250*	9.843	7.087	+0.001/-0.0004	7.28	0.59	1.56	8.46	0.16	0.55
K6	300*	11.811	9.055	+0.001/-0.001	7.87	0.67	1.42	10.43	0.16	0.55
K7	300	11.811	9.055	+0.001/-0.001	8.90	0.71	1.73	10.43	0.20	0.55
	350*	13.780	9.842	+0.000/-0.001				11.81		0.71
K8	350	13.780	9.842	+0.000/-0.001	11.10	0.79	1.77	11.81	0.20	0.71
	400*	15.748	11.811	+0.000/-0.001				13.78		
	450	17.717	13.781	+0.000/-0.001				15.75		
K9	450*	17.717	13.780	+0.000/-0.001	12.99	0.91	1.97	15.75	0.20	0.71
K10	550*	21.654	17.717	+0.000/-0.002	14.02	0.98	3.07	19.69	0.20	0.71

* This is the standard flange and will be shipped unless otherwise specified. Optional flanges are not available for all sizes.

K/KL Series: RIGHT ANGLE – Solid Shaft / Hollow Output

C Series: INLINE — Solid Shaft Output

C Series Features

- Input rating up to 105 HP
- Ratio options: 2:1 – 276:1
- Output Torque capability up to 53,000 lb-in
- NEMA input capabilities of 56C, 143/145TC, 182/184TC, 213/215TC, 254/256TC, 284/286TC, 324/326TC, 364/365TC
- Output shaft diameters from 1" – 3-5/8"
- Housing style options: feet, flange or tapped holes

C Series inline versatile gear drives offer you performance, durability, and economy for a wide range of constant speed applications. High efficiency helical gearing keeps motor size to a minimum while conserving energy.

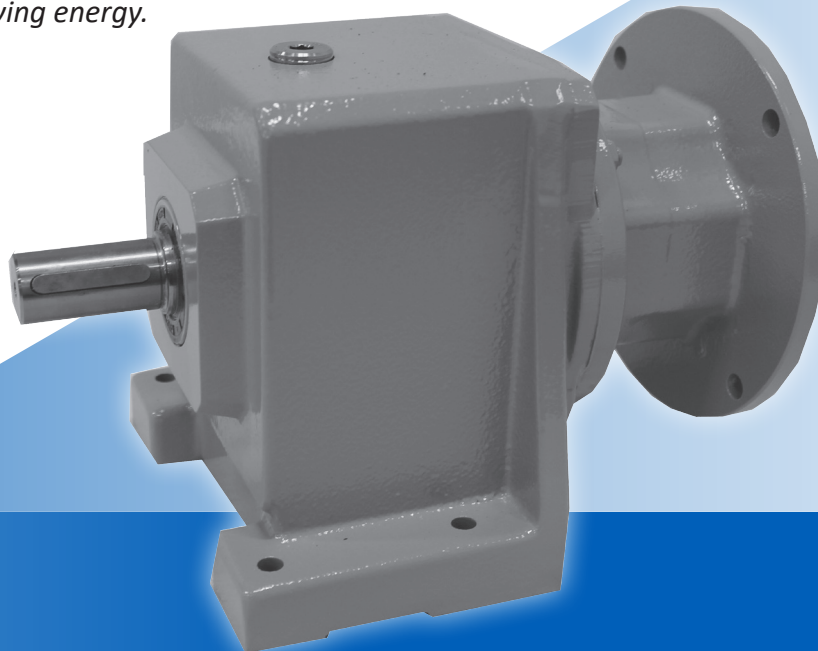

**SHIPS in
1 DAY!**
NO EXPEDITE FEE FOR 24
HOUR SERVICE

C Series Benefits

- No maintenance - totally enclosed with no breather to allow contaminants in or oil out
- Lubricated for life with Mobil oil
- Simple motor mounting and removal with Bowex coupling system
- Energy savings - up to 97% efficiency
- Easy installation with any horizontal mounting position
- Reliability guaranteed with 3 year warranty
- Durability - IP69K Certified to prevent water and dust ingress
- Assembled in USA
- Combine units to achieve slower speeds to meet your application needs

C Series Food & Corrosion Resistant Options

"F" Option for Food Duty Applications

- Totally enclosed unit — no breathers, maintenance free, lubricated for life
- Mobil SHC CIBUS 220 food grade oil
- Anti-microbial clear coat
- 316 stainless steel epoxy coating
- Stainless steel shaft, hollow bore or double bushing output
- USDA Accepted Equipment

"B" Option for Corrosion Resistant Duty Applications

- Totally enclosed unit — no breathers, maintenance free, lubricated for life
- Mobil 600XP220 mineral oil
- 316 stainless steel epoxy coating
- Stainless steel shaft, hollow bore or double bushing output

Other C Series Design Options Available:

- Plated or stainless steel hardware
- IP69K certified (see page 6 for full details)

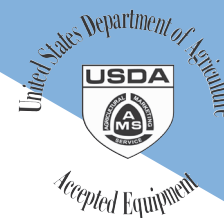

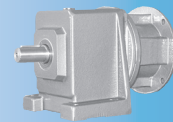

Overview

C Ordering Options At-a-Glance

C Series are available in a wide range of user-selected design options that tailor the speed reducer to your motor and exact application requirements. Use the appropriate order codes below to build a part number for the complete assembly.

Part Number Examples:

	1	2	3	4	5	6	7	8	9	0*
Standard duty	C	2	0	2	N	0040	MR140/	050		EL1
Food duty	C	2	0	2	N	0040	MR140/	050	F	EL1234

Design Option	Part Number Code	Description
1 Series	C	Concentric helical (output and input in line/gears are all helical)
2 Size	2	10 sizes of speed reducers (0 thru 9)
3 Generation	0 1	0 for sizes C0 thru C5; 1 for sizes C6 thru C9
4 # of Stages	2 3	Two or three stages (determined by ratio)
5 Housing	F	Output flange mount
	G	Pilot Circle Diameter (PCD) tapped holes
	N	Foot mounting
	Q	Square output flange (not bolt on)
6 Ratio	0040	Ratios range from 2:1 to 276:1 (refer to Selection Data tables) Note: if a slower speed is required, units can be combined to achieve the necessary ratio for low speed applications. Contact STÖBER Drives Inc.
7 Motor Adapter	MR140 thru MR350	Round motor adapter sizes (refer to Selection Data tables)
	050	56C
	140	143/145TC
	180	182/184TC
	210	213/215TC
	250	254/256TC
	280	284/286TC
320	324/326TC	
360	364/365TC	
8 NEMA Frame Size (refer to Selection Data tables)	250	254/256TC
	280	284/286TC
9 Food & Corrosion Resistant Option	F	Food duty service
	B	Corrosion resistant duty service
0 Mounting Position* <i>Refer to page 127 illustrations</i>	EL1 EL2	Mounting positions for 3 year warranty
	EL3 EL4	
	EL5 EL6	
	EL1234	
	EL5 EL6	

* Mounting position is added to "notes" section of order

C Series: INLINE — Solid Shaft Output

C Series: INLINE — Solid Shaft Output

C Series Orientation

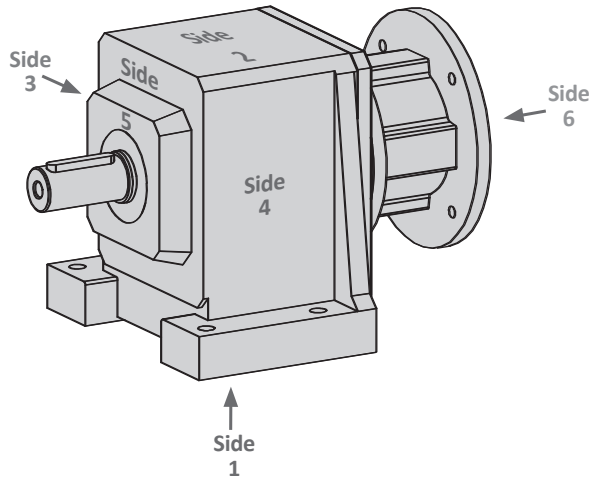

C Series Direction of Rotation

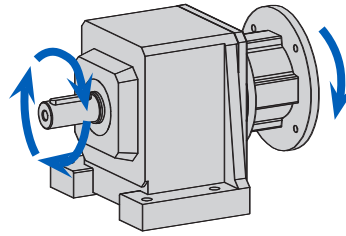

All 2 Stage Units

C002	C612
C102	C712
C202	C812
C302	C912
C402	
C502	

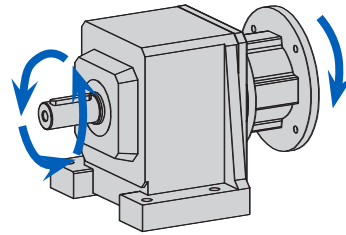

All 3 Stage Units

C103	C613
C203	C713
C303	C813
C403	C913
C503	

C Output and Housing Configurations

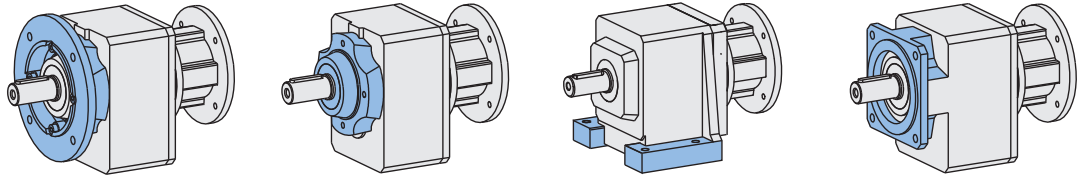

See Page	page 150	page 152	page 154	page 156
Housing Style	F Flange Mount	G Tapped Holes	N Foot Mount	Q Square Flange

Availability*

Standard Duty	C0-C9	C0-C9	C0-C9	C0-C4
Food & Corrosion Resistant Duty**	C0-C8	C0-C8	C0-C8	C0-C4

* Refer to Output Options chart below for standard and optional solid shaft options. Food and Corrosion Resistant Duty require stainless steel.

** On C6 and above, food and corrosion resistant duty availability is dependent on mounting position, ratio, input speed and ambient temperature. Breathers may be required. Please contact the factory for support.

C Series Output Options

BLUE: standard output diameters in stock

BLACK: optional diameters in stock

Other options are available upon request. Please contact STÖBER to learn about other options and their deliveries.

			C0	C1	C2	C3	C4	C5	C6	C7	C8	C9
Solid Shaft	Carbon Steel	Inches	3/4	1	1-1/4	1-1/4	1-5/8	1-5/8	2-1/8	2-3/8	2-7/8	3-5/8
		Metric	20	25	30	30	40	40	50	60	70	90
	Stainless Steel	Inches	3/4	1	1-1/4	1-1/4	1-5/8	1-5/8	2-1/8	2-3/8	2-7/8	—
		Metric	—	—	—	25	—	—	—	—	—	—

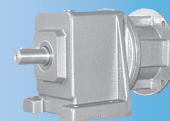

Overview

C Series: INLINE — Solid Shaft Output

C Mounting Position Options

When ordering any C unit, the mounting position must be specified. Use one of the mounting position order codes illustrated below that corresponds to the intended application.

Standard Duty

All STÖBER standard duty units are filled with the correct amount of lubrication before shipping. In order to provide the proper lubrication quantity, the mounting position must be specified at the time the unit is ordered.

DO NOT mount any reducer in a position other than the mounting position specified on the order!

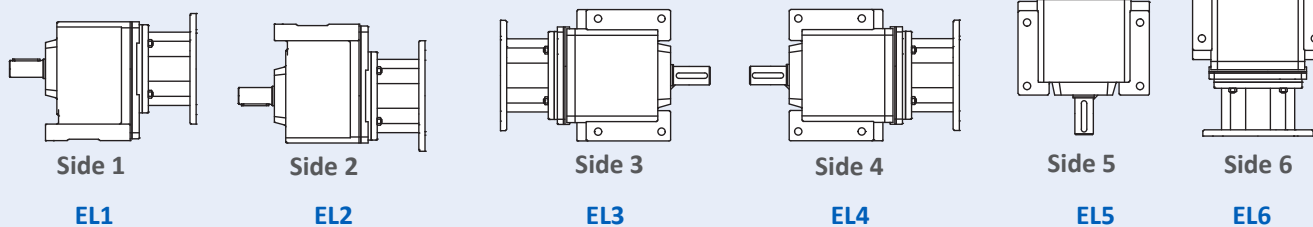

Food & Corrosion Resistant Duty

Food and Corrosion Resistant Duty units are equipped with specialized seals, higher oil level, and additional features compared to standard units. These added features enable all horizontal output positions (EL1, 2, 3 and 4) to be used interchangeably, subject to size and ratio. On C6 and above, food and corrosion resistant duty availability is dependent on mounting position, ratio, input speed and ambient temperature. Breathers may be required. Please contact the factory for support. Contact STÖBER for details.

DO NOT mount horizontal Food and Corrosion Resistant Duty reducers in a vertical position, or mount vertical position reducers other than specified on the order!

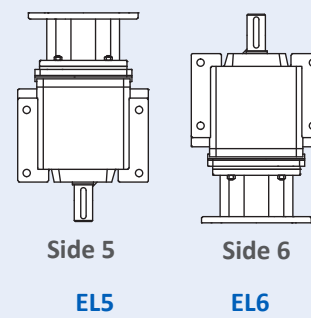
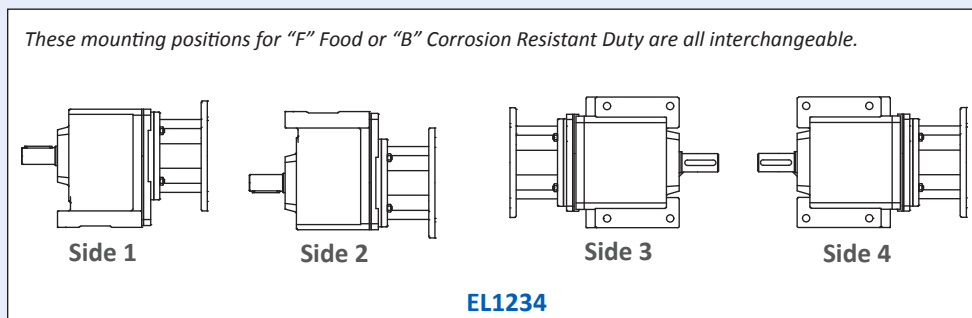

Permissible Motor Tilting Torque

The permissible tilting torque of the motor attached to the gear unit is a result of the static and dynamic load "F" from the motor weight, mass acceleration, and vibration multiplied by the distance from the center of gravity "l_s" of the motor.

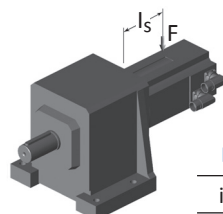

$$M_{1k} = F \times l_s \leq M_{1k}$$

M _{1k}	MR140	MR160	MR200	MR250	MR300	MR350
in.lbs	221	531	1106	2212	5310	10,620

C Series: INLINE — Solid Shaft Output

C Series Lubrication Maintenance

C002 thru C502/C503 are supplied without breathers and are lubricated for life and maintenance free.

Breathers are provided on standard units C612/C613 thru C912/C913, located as shown*. STOBBER recommends changing the lubrication in breather supplied units after 10,000 hours for normal operating conditions or every 5,000 hours for wet operating conditions.

**C612/C613 and larger units with the Food & Corrosion Resistant option can exclude a breather. Contact STOBBER for details.*

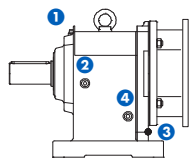

2 Stage Units
(C612 thru C912)

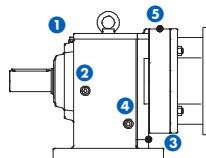

3 Stage Units
(C613 thru C913)

Drain Plug and Vent Location

Mounting Position	1	2 *	2a *	3	5
EL1	Vent			Drain	
EL2	Drain			Vent	
EL3		Vent	Drain		
EL4		Drain	Vent		
EL5	C612-C912	Drain		Vent	
		C613-C913	Drain		Vent
EL6	Vent			Drain	

* Position 2a is on the opposite side of 2.

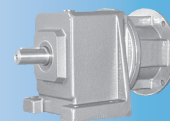

Selection Data

C Sizing/Selection:

1. Find the **RPM Output (Approximate)** nearest the application requirement. (If the exact Output RPM is required, divide the Input RPM [1750] by the value listed in the Nominal Ratio column.)
- 2a. In the **Input HP** column, locate the rating that is greater than or equal to the required HP, or;
- 2b. If selection is based on Torque instead of HP, find an **Output Torque** that is equal to or greater than required.
3. Confirm that the **Overhung Load** is acceptable for the application.
4. Choose the appropriate **Base Module**, **Motor Adapter** and **NEMA C-Frame** part number order codes (see page 125 for complete ordering information). An optional input shaft, in place of the NEMA C-face motor adapter, is also available.

1750 RPM Input		Nominal Ratio	Overhung Load Output Shaft ¹⁾ (lbs)	Part Number Codes (in blue)		
Input HP	Output Torque (lb-in)			Base Module	Motor Adapter/ NEMA Motor	Compatible NEMA C-Frame ²⁾ with Designated Motor Adapter
875 RPM Output (Approximate)						
4.17*	291	1.997	121	C002_0020	MR160/050	56C
					MR160/140	143/145TC
21.97*	1,512	1.968	616	C402_0020	MR200/180	182/184TC
24.58*	1,698	1.976	700	C502_0020	MR200/180	182/184TC
30.65*	2,109	1.968	616	C402_0020	MR250/210	213/215TC
39.32*	2,717	1.976	700	C502_0020	MR250/210	213/215TC
47.38*	3,273	1.976	700	C502_0020	MR300/250	254/256TC
					MR300/280	284/286TC
730 RPM Output (Approximate)						
7.40*	619	2.394	231	C102_0024	MR160/050	56C
					MR160/140	143/145TC
					MR200/180	182/184TC
705 RPM Output (Approximate)						
8.73*	755	2.475	288	C202_0025	MR160/050	56C
					MR160/140	143/145TC
9.22	809	2.510	389	C302_0025	MR160/050	56C
					MR160/140	143/145TC
11.05*	956	2.475	288	C202_0025	MR200/180	182/184TC
17.59*	1,544	2.510	389	C302_0025	MR200/180	182/184TC
17.92*	1,572	2.510	389	C302_0025	MR250/210	213/215TC
680 RPM Output (Approximate)						
7.03*	635	2.582	236	C102_0026	MR160/050	56C
					MR160/140	143/145TC
					MR200/180	182/184TC

C Series: INLINE — Solid Shaft Output

1) Overhung Load is measured at the center of the shaft extension.

2) Motor HP for TEFC NEMA C-Frame @ 1750 RPM

Order Code	050	140	180	210	250	280	320	360
C-Frame	56C	143/145TC	182/184TC	213/215TC	254/256TC	284/286TC	324/326TC	364/365TC
HP	1/4 to 1-1/2	1, 1-1/2, 2	3, 5	7-1/2, 10	15, 20	25, 30	40, 50	60, 75

* Thermal HP Limit

Base Module Size	C0	C1	C2	C3	C4	C5	C6	C7	C8	C9
HP Limit	2.95	5.36	7.38	12.34	14.75	20.12	29.50	40.23	53.63	67.05

C Series: INLINE — Solid Shaft Output

1750 RPM Input		Nominal Ratio	Overhung Load Output Shaft ¹⁾ (lbs.)	Part Number Codes (in blue)		
Input HP	Output Torque (in. lbs.)			Base Module	Motor Adapter/ NEMA Motor	Compatible NEMA C-Frame ²⁾ with Designated Motor Adapter
650 RPM Output (Approximate)						
8.73*	821	2.690	296	C202_0027	MR160/050	56C
					MR160/140	143/145TC
9.22	872	2.705	399	C302_0027	MR160/050	56C
					MR160/140	143/145TC
10.45*	983	2.690	296	C202_0027	MR200/180	182/184TC
17.04*	1,612	2.705	399	C302_0027	MR200/180	182/184TC
					MR250/210	213/215TC
565 RPM Output (Approximate)						
3.14*	336	3.067	140	C002_0031	MR160/050	56C
					MR160/140	143/145TC
17.04*	1,846	3.099	717	C402_0031	MR200/180	182/184TC
19.60	2,108	3.077	811	C502_0031	MR200/180	182/184TC
22.64*	2,454	3.099	717	C402_0031	MR250/210	213/215TC
34.42*	3,703	3.077	811	C502_0031	MR250/210	213/215TC
35.26*	3,794	3.077	811	C502_0031	MR300/250	254/256TC
					MR300/280	284/286TC
525 RPM Output (Approximate)						
2.97*	345	3.318	144	C002_0033	MR160/050	56C
					MR160/140	143/145TC
450 RPM Output (Approximate)						
5.36	727	3.883	271	C102_0039	MR160/050	56C
					MR160/140	143/145TC
					MR200/180	182/184TC
6.87	934	3.888	335	C202_0039	MR160/050	56C
					MR160/140	143/145TC
7.70	1,044	3.878	450	C302_0039	MR160/050	56C
					MR160/140	143/145TC
8.18*	1,111	3.888	335	C202_0039	MR200/180	182/184TC
13.41*	1,818	3.878	450	C302_0039	MR200/180	182/184TC
					MR250/210	213/215TC

1) Overhung Load is measured at the center of the shaft extension.

2) Motor HP for TEFC NEMA C-Frame @ 1750 RPM

Order Code	050	140	180	210	250	280	320	360
C-Frame	56C	143/145TC	182/184TC	213/215TC	254/256TC	284/286TC	324/326TC	364/365TC
HP	1/4 to 1-1/2	1, 1-1/2, 2	3, 5	7-1/2, 10	15, 20	25, 30	40, 50	60, 75

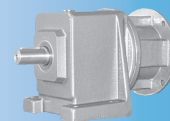

Selection Data

1750 RPM Input		Nominal Ratio	Overhung Load Output Shaft ¹⁾ (lbs.)	Part Number Codes (in blue)		
Input HP	Output Torque (in. lbs.)			Base Module	Motor Adapter/ NEMA Motor	Compatible NEMA C-Frame ²⁾ with Designated Motor Adapter
420 RPM Output (Approximate)						
5.09	746	4.189	278	C102_0042	MR160/050	56C
					MR160/140	143/145TC
					MR200/180	182/184TC
6.87	1,016	4.226	344	C202_0042	MR160/050	56C
					MR160/140	143/145TC
7.70	1,125	4.179	461	C302_0042	MR160/050	56C
					MR160/140	143/145TC
7.73*	1,143	4.226	344	C202_0042	MR200/180	182/184TC
					MR200/180	182/184TC
12.75*	1,864	4.179	461	C302_0042	MR250/210	213/215TC
					MR250/210	213/215TC
24.58	3,595	4.184	1,307	C612_0042	MR200/180	182/184TC
39.32*	5,752	4.184	1,307	C612_0042	MR250/210	213/215TC
53.33*	7,802	4.184	1,307	C612_0042	MR300/250	254/256TC
					MR300/280	284/286TC
105.20*	15,541	4.225	2,458	C812_0042	MR350/320	324/326TC
					MR350/360	364/365TC
410 RPM Output (Approximate)						
24.58	3,659	4.259	1,807	C712_0043	MR200/180	182/184TC
39.32	5,855	4.259	1,807	C712_0043	MR250/210	213/215TC
73.72*	10,978	4.259	1,807	C712_0043	MR300/250	254/256TC
					MR300/280	284/286TC
375 RPM Output (Approximate)						
2.37	387	4.680	161	C002_0047	MR160/050	56C
					MR160/140	143/145TC
4.75	773	4.658	288	C102_0047	MR160/050	56C
					MR160/140	143/145TC
					MR200/180	182/184TC
5.98	975	4.667	356	C202_0047	MR160/050	56C
					MR160/140	143/145TC
6.66	1,088	4.675	479	C302_0047	MR160/050	56C
					MR160/140	143/145TC
7.24	1,181	4.667	356	C202_0047	MR200/180	182/184TC
7.57	1,238	4.682	822	C402_0047	MR160/050	56C
					MR160/140	143/145TC
8.68	1,404	4.629	929	C502_0046	MR160/050	56C
					MR160/140	143/145TC
11.62	1,899	4.675	479	C302_0047	MR200/180	182/184TC
11.84	1,935	4.675	479	C302_0047	MR250/180	182/184TC
					MR250/210	213/215TC

C Series: INLINE — Solid Shaft Output

* Thermal HP Limit

Base Module Size	C0	C1	C2	C3	C4	C5	C6	C7	C8	C9
HP Limit	2.95	5.36	7.38	12.34	14.75	20.12	29.50	40.23	53.63	67.05

C Series: INLINE — Solid Shaft Output

1750 RPM Input		Nominal Ratio	Overhung Load Output Shaft ¹⁾ (lbs.)	Part Number Codes (in blue)		
Input HP	Output Torque (in. lbs.)			Base Module	Motor Adapter/ NEMA Motor	Compatible NEMA C-Frame ²⁾ with Designated Motor Adapter
375 RPM Output (Approximate) Continued						
13.28	2,174	4.682	822	C402_0047	MR200/180	182/184TC
15.25	2,468	4.629	929	C502_0046	MR200/180	182/184TC
17.20*	2,815	4.682	822	C402_0047	MR250/180	182/184TC
					MR250/210	213/215TC
26.64*	4,312	4.629	929	C502_0046	MR250/180	182/184TC
					MR250/210	213/215TC
26.86*	4,347	4.629	929	C502_0046	MR300/250	254/256TC
					MR300/280	284/286TC
345 RPM Output (Approximate)						
2.25	397	5.063	165	C002_0051	MR160/050	56C
					MR160/140	143/145TC
4.51	793	5.025	295	C102_0050	MR160/050	56C
					MR160/140	143/145TC
5.98	1,060	5.072	366	C202_0051	MR200/180	182/184TC
					MR160/050	56C
6.66	1,173	5.038	491	C302_0050	MR160/140	143/145TC
					MR160/050	56C
6.85	1,214	5.072	366	C202_0051	MR160/140	143/145TC
					MR200/180	182/184TC
11.26	1,983	5.038	491	C302_0050	MR200/180	182/184TC
					MR250/210	213/215TC
300 RPM Output (Approximate)						
4.07	835	5.875	311	C102_0059	MR160/050	56C
					MR160/140	143/145TC
5.12	1,036	5.791	382	C202_0058	MR200/180	182/184TC
					MR160/050	56C
5.86	1,201	5.859	516	C302_0059	MR160/140	143/145TC
					MR160/050	56C
6.27	1,269	5.791	382	C202_0058	MR200/180	182/184TC
					MR200/180	182/184TC
10.18	2,086	5.859	516	C302_0059	MR250/210	213/215TC
					MR250/210	213/215TC

1) Overhung Load is measured at the center of the shaft extension.

2) Motor HP for TEFC NEMA C-Frame @ 1750 RPM

Order Code	050	140	180	210	250	280	320	360
C-Frame	56C	143/145TC	182/184TC	213/215TC	254/256TC	284/286TC	324/326TC	364/365TC
HP	1/4 to 1-1/2	1, 1-1/2, 2	3, 5	7-1/2, 10	15, 20	25, 30	40, 50	60, 75

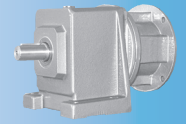

Selection Data

1750 RPM Input		Nominal Ratio	Overhung Load Output Shaft ¹⁾ (lbs.)	Part Number Codes (in blue)		
Input HP	Output Torque (in. lbs.)			Base Module	Motor Adapter/ NEMA Motor	Compatible NEMA C-Frame ²⁾ with Designated Motor Adapter

275 RPM Output (Approximate)

3.87	856	6.338	319	C102_0063	MR160/050	56C
					MR160/140	143/145TC
					MR200/180	182/184TC
5.12	1,127	6.295	393	C202_0063	MR160/050	56C
					MR160/140	143/145TC
5.86	1,294	6.314	529	C302_0063	MR160/050	56C
					MR160/140	143/145TC
5.93	1,305	6.295	393	C202_0063	MR200/180	182/184TC
					MR200/180	182/184TC
9.69	2,138	6.314	529	C302_0063	MR200/180	182/184TC
					MR250/210	213/215TC

265 RPM Output (Approximate)

21.48	4,895	6.518	1,515	C612_0065	MR200/180	182/184TC
37.98*	8,656	6.518	1,515	C612_0065	MR250/210	213/215TC
39.69*	9,045	6.518	1,515	C612_0065	MR300/250	254/256TC
					MR300/280	284/286TC
73.72*	17,193	6.670	2,862	C812_0067	MR300/180	182/184TC
					MR300/210	213/215TC
					MR300/250	254/256TC
					MR300/280	284/286TC
105.09*	24,508	6.670	2,862	C812_0067	MR350/320	324/326TC
					MR350/360	364/365TC

225 RPM Output (Approximate)

1.70	457	7.714	190	C002_0077	MR160/050	56C
					MR160/140	143/145TC
4.03	1,100	7.800	422	C202_0078	MR160/050	56C
					MR160/140	143/145TC
5.11	1,396	7.816	976	C402_0078	MR160/050	56C
					MR160/140	143/145TC
5.14	1,402	7.800	422	C202_0078	MR200/180	182/184TC
					MR200/180	182/184TC
5.97	1,621	7.763	1,104	C502_0078	MR160/050	56C
					MR160/140	143/145TC
8.38	2,299	7.841	569	C302_0078	MR250/210	213/215TC
8.95	2,446	7.816	976	C402_0078	MR200/180	182/184TC
10.48	2,846	7.763	1,104	C502_0078	MR200/180	182/184TC
					MR200/180	182/184TC
12.22	3,340	7.816	976	C402_0078	MR250/180	182/184TC
					MR250/210	213/215TC
18.30	4,966	7.763	1,104	C502_0078	MR250/210	213/215TC
					MR250/210	213/215TC
19.03	5,165	7.763	1,104	C502_0078	MR300/210	213/215TC
					MR300/250	254/256TC

* Thermal HP Limit

Base Module Size	C0	C1	C2	C3	C4	C5	C6	C7	C8	C9
HP Limit	2.95	5.36	7.38	12.34	14.75	20.12	29.50	40.23	53.63	67.05

C Series: INLINE — Solid Shaft Output

C Series: INLINE — Solid Shaft Output

1750 RPM Input		Nominal Ratio	Overhung Load Output Shaft ¹⁾ (lbs.)	Part Number Codes (in blue)		
Input HP	Output Torque (in. lbs.)			Base Module	Motor Adapter/ NEMA Motor	Compatible NEMA C-Frame ²⁾ with Designated Motor Adapter
210 RPM Output (Approximate)						
1.85	531	8.235	194	C002_0082	MR160/050	56C
					MR160/140	143/145TC
16.37*	4,742	8.285	995	C402_0083	MR200/180	182/184TC
					MR250/210	213/215TC
19.60	5,661	8.263	1,127	C502_0083	MR200/180	182/184TC
205 RPM Output (Approximate)						
22.11	6,564	8.490	2,275	C712_0085	MR200/180	182/184TC
39.12	11,612	8.490	2,275	C712_0085	MR250/210	213/215TC
55.08*	16,349	8.490	2,275	C712_0085	MR300/250	254/256TC
					MR300/280	284/286TC
195 RPM Output (Approximate)						
21.48	6,848	9.118	1,694	C612_0091	MR200/180	182/184TC
					MR250/210	213/215TC
31.73*	10,115	9.118	1,694	C612_0091	MR300/250	254/256TC
					MR300/280	284/286TC
73.72*	23,310	9.043	3,168	C812_0090	MR300/180	182/184TC
					MR300/210	213/215TC
					MR300/250	254/256TC
85.79*	27,125	9.043	3,168	C812_0090	MR300/280	284/286TC
					MR350/320	324/326TC
190 RPM Output (Approximate)						
1.65	531	9.228	202	C002_0092	MR160/050	56C
					MR160/140	143/145TC
15.05*	4,872	9.261	1,032	C402_0093	MR200/180	182/184TC
					MR250/210	213/215TC
19.60	6,345	9.261	1,171	C502_0093	MR200/180	182/184TC
21.89*	7,086	9.261	1,171	C502_0093	MR250/210	213/215TC
					MR300/250	254/256TC

1) Overhung Load is measured at the center of the shaft extension.

2) Motor HP for TEFC NEMA C-Frame @ 1750 RPM

Order Code	050	140	180	210	250	280	320	360
C-Frame	56C	143/145TC	182/184TC	213/215TC	254/256TC	284/286TC	324/326TC	364/365TC
HP	1/4 to 1-1/2	1, 1-1/2, 2	3, 5	7-1/2, 10	15, 20	25, 30	40, 50	60, 75

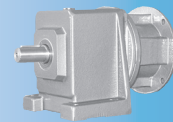

Selection Data

1750 RPM Input		Nominal Ratio	Overhung Load Output Shaft ¹⁾ (lbs.)	Part Number Codes (in blue)		
Input HP	Output Torque (in. lbs.)			Base Module	Motor Adapter/ NEMA Motor	Compatible NEMA C-Frame ²⁾ with Designated Motor Adapter
175 RPM Output (Approximate)						
15.67	5,538	10.111	1,753	C612_0100	MR200/180	182/184TC
27.75	9,810	10.111	1,753	C612_0100	MR250/210	213/215TC
29.62*	10,470	10.111	1,753	C612_0100	MR300/250	254/256TC
					MR300/280	284/286TC
73.72*	26,166	10.151	3,292	C812_0100	MR300/180	182/184TC
					MR300/210	213/215TC
					MR300/250	254/256TC
					MR300/280	284/286TC
79.43*	28,190	10.151	3,292	C812_0100	MR350/320	324/326TC
					MR350/360	364/365TC
170 RPM Output (Approximate)						
2.93	1,063	10.383	376	C102_0105	MR160/050	56C
					MR160/140	143/145TC
					MR200/180	182/184TC
4.94	1,772	10.260	463	C202_0105	MR160/050	56C
					MR160/140	143/145TC
					MR200/180	182/184TC
7.70	2,770	10.286	623	C302_0105	MR160/050	56C
					MR160/140	143/145TC
8.45	3,037	10.286	623	C302_0105	MR200/180	182/184TC
					MR250/210	213/215TC
150 RPM Output (Approximate)						
2.60	1,063	11.717	391	C102_0115	MR160/050	56C
					MR160/140	143/145TC
					MR200/180	182/184TC
4.31	1,772	11.760	484	C202_0120	MR160/050	56C
					MR160/140	143/145TC
					MR200/180	182/184TC
7.64	3,100	11.607	648	C302_0115	MR160/050	56C
					MR160/140	143/145TC
					MR200/180	182/184TC
					MR250/210	213/215TC
22.11	9,093	11.761	2,536	C712_0120	MR200/180	182/184TC
39.12	16,086	11.761	2,536	C712_0120	MR250/210	213/215TC
43.08*	17,716	11.761	2,536	C712_0120	MR300/250	254/256TC
					MR300/280	284/286TC

C Series: INLINE — Solid Shaft Output

* Thermal HP Limit

Base Module Size	C0	C1	C2	C3	C4	C5	C6	C7	C8	C9
HP Limit	2.95	5.36	7.38	12.34	14.75	20.12	29.50	40.23	53.63	67.05

C Series: INLINE — Solid Shaft Output

1750 RPM Input		Nominal Ratio	Overhung Load Output Shaft ¹⁾ (lbs.)	Part Number Codes (in blue)		
Input HP	Output Torque (in. lbs.)			Base Module	Motor Adapter/ NEMA Motor	Compatible NEMA C-Frame ²⁾ with Designated Motor Adapter
140 RPM Output (Approximate)						
1.21	531	12.567	224	C002_0125	MR160/050	56C
					MR160/140	143/145TC
2.44	1,063	12.455	399	C102_0125	MR160/050	56C
					MR160/140	143/145TC
					MR200/180	182/184TC
4.11	1,772	12.315	492	C202_0125	MR160/050	56C
					MR160/140	143/145TC
					MR200/180	182/184TC
6.66	2,887	12.400	663	C302_0125	MR160/050	56C
					MR160/140	143/145TC
7.15	3,100	12.400	663	C302_0125	MR200/180	182/184TC
					MR250/210	213/215TC
7.57	3,311	12.519	1,141	C402_0125	MR160/050	56C
					MR160/140	143/145TC
8.68	3,771	12.429	1,291	C502_0125	MR160/050	56C
					MR160/140	143/145TC
11.13	4,872	12.519	1,141	C402_0125	MR200/180	182/184TC
					MR250/210	213/215TC
15.25	6,626	12.429	1,291	C502_0125	MR200/180	182/184TC
					MR250/210	213/215TC
16.31	7,086	12.429	1,291	C502_0125	MR300/250	254/256TC
					MR250/180	182/184TC
35.15	15,670	12.749	3,552	C812_0125	MR250/210	213/215TC
					MR300/250	254/256TC
62.77*	27,978	12.749	3,552	C812_0125	MR300/280	284/286TC
					MR350/320	324/326TC
68.23*	30,415	12.749	3,552	C812_0125	MR350/360	364/365TC
130 RPM Output (Approximate)						
15.67	7,220	13.182	2,634	C712_0130	MR200/180	182/184TC

1) Overhung Load is measured at the center of the shaft extension.

2) Motor HP for TEFC NEMA C-Frame @ 1750 RPM

Order Code	050	140	180	210	250	280	320	360
C-Frame	56C	143/145TC	182/184TC	213/215TC	254/256TC	284/286TC	324/326TC	364/365TC
HP	1/4 to 1-1/2	1, 1-1/2, 2	3, 5	7-1/2, 10	15, 20	25, 30	40, 50	60, 75

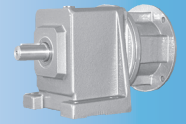

Selection Data

1750 RPM Input		Nominal Ratio	Overhung Load Output Shaft ¹⁾ (lbs.)	Part Number Codes (in blue)		
Input HP	Output Torque (in. lbs.)			Base Module	Motor Adapter/ NEMA Motor	Compatible NEMA C-Frame ²⁾ with Designated Motor Adapter
125 RPM Output (Approximate)						
1.08	531	14.083	233	C002_0140	MR160/050	56C
					MR160/140	143/145TC
2.16	1,063	14.056	416	C102_0140	MR160/050	56C
					MR160/140	143/145TC
3.59	1,772	14.115	514	C202_0140	MR160/050	56C
					MR160/140	143/145TC
					MR200/180	182/184TC
6.34	3,100	13.993	690	C302_0140	MR160/050	56C
					MR160/140	143/145TC
					MR200/180	182/184TC
					MR250/210	213/215TC
7.57	3,701	13.993	1,185	C402_0140	MR160/050	56C
					MR160/140	143/145TC
8.68	4,226	13.929	1,341	C502_0140	MR160/050	56C
					MR160/140	143/145TC
9.96	4,872	13.993	1,185	C402_0140	MR200/180	182/184TC
					MR250/210	213/215TC
14.55	7,086	13.929	1,341	C502_0140	MR200/180	182/184TC
					MR250/210	213/215TC
15.67	7,748	14.145	1,961	C612_0140	MR200/180	182/184TC
					MR250/210	213/215TC
23.28	11,515	14.145	1,961	C612_0140	MR250/210	213/215TC
					MR300/250	254/256TC
64.84*	31,201	13.763	3,644	C812_0140	MR300/180	182/184TC
					MR300/210	213/215TC
					MR300/250	254/256TC
					MR300/280	284/286TC
					MR350/320	324/326TC
					MR350/360	364/365TC

C Series: INLINE — Solid Shaft Output

115 RPM Output (Approximate)						
1.94	1,063	15.708	432	C102_0155	MR160/050	56C
					MR160/140	143/145TC
					MR200/180	182/184TC
3.32	1,772	15.283	528	C202_0155	MR160/050	56C
					MR160/140	143/145TC
					MR200/180	182/184TC
5.71	3,100	15.543	715	C302_0155	MR160/050	56C
					MR160/140	143/145TC
					MR200/180	182/184TC

* Thermal HP Limit

Base Module Size	C0	C1	C2	C3	C4	C5	C6	C7	C8	C9
HP Limit	2.95	5.36	7.38	12.34	14.75	20.12	29.50	40.23	53.63	67.05

C Series: INLINE — Solid Shaft Output

1750 RPM Input		Nominal Ratio	Overhung Load Output Shaft ¹⁾ (lbs.)	Part Number Codes (in blue)		
Input HP	Output Torque (in. lbs.)			Base Module	Motor Adapter/ NEMA Motor	Compatible NEMA C-Frame ²⁾ with Designated Motor Adapter
105 RPM Output (Approximate)						
11.33	6,419	16.203	2,052	C612_0160	MR200/180	182/184TC
27.75	16,592	17.101	3,917	C812_0170	MR250/180	182/184TC
					MR250/210	213/215TC
49.56	29,635	17.101	3,917	C812_0170	MR300/250	254/256TC
					MR300/280	284/286TC
58.79	33,841	16.463	4,770	C912_0165	MR300/180	182/184TC
					MR300/210	213/215TC
					MR300/250	254/256TC
					MR300/280	284/286TC
78.29*	45,063	16.463	4,770	C912_0165	MR350/320	324/326TC
					MR350/360	364/365TC
100 RPM Output (Approximate)						
1.72	1,063	17.727	449	C102_0175	MR160/050	56C
					MR160/140	143/145TC
2.89	1,772	17.517	553	C202_0175	MR160/050	56C
					MR160/140	143/145TC
5.06	3,100	17.540	744	C302_0175	MR160/050	56C
					MR160/140	143/145TC
					MR200/180	182/184TC
35.15	21,248	17.287	3,931	C812_0175	MR250/180	182/184TC
					MR250/210	213/215TC
52.76	31,889	17.287	3,931	C812_0175	MR300/250	254/256TC
					MR300/280	284/286TC
90 RPM Output (Approximate)						
15.67	10,002	18.261	2,936	C712_0185	MR200/180	182/184TC
24.72	17,511	20.257	4,145	C812_0200	MR250/180	182/184TC
					MR250/210	213/215TC
27.75	17,716	18.261	2,936	C712_0185	MR250/210	213/215TC
					MR300/250	254/256TC
					MR300/280	284/286TC
43.99	31,156	20.257	4,145	C812_0200	MR300/250	254/256TC
					MR300/280	284/286TC
50.44	35,541	20.152	5,103	C912_0200	MR300/180	182/184TC
					MR300/210	213/215TC
					MR300/250	254/256TC
					MR300/280	284/286TC

1) Overhung Load is measured at the center of the shaft extension.

2) Motor HP for TEFC NEMA C-Frame @ 1750 RPM

Order Code	050	140	180	210	250	280	320	360
C-Frame	56C	143/145TC	182/184TC	213/215TC	254/256TC	284/286TC	324/326TC	364/365TC
HP	1/4 to 1-1/2	1, 1-1/2, 2	3, 5	7-1/2, 10	15, 20	25, 30	40, 50	60, 75

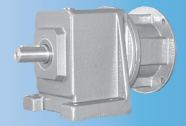

Selection Data

1750 RPM Input		Nominal Ratio	Overhung Load Output Shaft ¹⁾ (lbs.)	Part Number Codes (in blue)		
Input HP	Output Torque (in. lbs.)			Base Module	Motor Adapter/ NEMA Motor	Compatible NEMA C-Frame ²⁾ with Designated Motor Adapter
85 RPM Output (Approximate)						
0.73	531	20.714	264	C002_0210	MR160/050	56C
					MR160/140	143/145TC
2.46	1,772	20.583	583	C202_0210	MR160/050	56C
					MR160/140	143/145TC
5.11	3,732	20.899	1,354	C402_0210	MR160/050	56C
					MR160/140	143/145TC
5.97	4,353	20.844	1,534	C502_0210	MR160/050	56C
					MR160/140	143/145TC
6.67	4,872	20.899	1,354	C402_0210	MR200/180	182/184TC
					MR250/210	213/215TC
9.72	7,086	20.844	1,534	C502_0210	MR200/180	182/184TC
					MR250/210	213/215TC
11.33	8,189	20.672	3,060	C712_0210	MR200/180	182/184TC
19.95	14,416	20.672	3,060	C712_0210	MR250/210	213/215TC
29.41	21,259	20.672	3,060	C712_0210	MR300/210	213/215TC
					MR300/250	254/256TC
					MR300/280	284/286TC
75 RPM Output (Approximate)						
0.65	531	23.214	275	C002_0230	MR160/050	56C
					MR160/140	143/145TC
2.15	1,772	23.593	611	C202_0240	MR160/050	56C
					MR160/140	143/145TC
5.11	4,172	23.359	1,405	C402_0230	MR160/050	56C
					MR160/140	143/145TC
5.97	4,872	23.359	1,405	C402_0230	MR200/180	182/184TC
5.97	4,879	23.359	1,594	C502_0230	MR160/050	56C
					MR160/140	143/145TC
8.68	7,086	23.359	1,594	C502_0230	MR200/180	182/184TC
					MR250/210	213/215TC
11.33	8,979	22.667	2,295	C612_0230	MR200/180	182/184TC
14.53	11,515	22.667	2,295	C612_0230	MR250/210	213/215TC
					MR300/250	254/256TC
27.75	22,498	23.188	4,336	C812_0230	MR250/180	182/184TC
					MR250/210	213/215TC
39.33	31,889	23.188	4,336	C812_0230	MR300/250	254/256TC
					MR300/280	284/286TC

C Series: INLINE — Solid Shaft Output

* Thermal HP Limit

Base Module Size	C0	C1	C2	C3	C4	C5	C6	C7	C8	C9
HP Limit	2.95	5.36	7.38	12.34	14.75	20.12	29.50	40.23	53.63	67.05

C Series: INLINE — Solid Shaft Output

1750 RPM Input		Nominal Ratio	Overhung Load Output Shaft ¹⁾ (lbs.)	Part Number Codes (in blue)		
Input HP	Output Torque (in. lbs.)			Base Module	Motor Adapter/ NEMA Motor	Compatible NEMA C-Frame ²⁾ with Designated Motor Adapter
75 RPM Output (Approximate) Continued						
54.10	47,894	25.342	5,508	C912_0250	MR350/320	324/326TC
					MR350/360	364/365TC
64.99	53,148	23.390	5,363	C912_0230	MR350/320	324/326TC
					MR350/360	364/365TC
70 RPM Output (Approximate)						
0.61	531	24.972	281	C002_0250	MR160/050	56C
1.21	1,063	25.133	505	C102_0250	MR160/050	56C
					MR160/140	143/145TC
2.06	1,772	24.641	619	C202_0250	MR160/050	56C
					MR160/140	143/145TC
3.58	3,100	24.800	835	C302_0250	MR160/050	56C
					MR160/140	143/145TC
					MR200/180	182/184TC
4.50	3,925	24.923	1,436	C402_0250	MR160/050	56C
					MR160/140	143/145TC
5.59	4,872	24.923	1,436	C402_0250	MR200/180	182/184TC
8.00	6,971	24.928	2,369	C612_0250	MR200/180	182/184TC
14.04	12,235	24.928	2,369	C612_0250	MR250/180	182/184TC
					MR250/210	213/215TC
14.74	12,844	24.928	2,369	C612_0250	MR300/210	213/215TC
19.95	18,173	26.058	4,508	C812_0260	MR250/180	182/184TC
					MR250/210	213/215TC
35.44	32,285	26.058	4,508	C812_0260	MR300/210	213/215TC
					MR300/250	254/256TC
					MR300/280	284/286TC
41.49	36,763	25.342	5,508	C912_0250	MR300/180	182/184TC
					MR300/210	213/215TC
					MR300/250	254/256TC
					MR300/280	284/286TC

1) Overhung Load is measured at the center of the shaft extension.

2) Motor HP for TEFC NEMA C-Frame @ 1750 RPM

Order Code	050	140	180	210	250	280	320	360
C-Frame	56C	143/145TC	182/184TC	213/215TC	254/256TC	284/286TC	324/326TC	364/365TC
HP	1/4 to 1-1/2	1, 1-1/2, 2	3, 5	7-1/2, 10	15, 20	25, 30	40, 50	60, 75

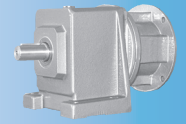

Selection Data

1750 RPM Input		Nominal Ratio	Overhung Load Output Shaft ¹⁾ (lbs.)	Part Number Codes (in blue)		
Input HP	Output Torque (in. lbs.)			Base Module	Motor Adapter/ NEMA Motor	Compatible NEMA C-Frame ²⁾ with Designated Motor Adapter

60 RPM Output (Approximate)

0.54	531	27.986	292	C002_0280	MR160/050	56C
1.07	1,063	28.364	526	C102_0280	MR160/050	56C
					MR160/140	143/145TC
1.79	1,772	28.243	648	C202_0280	MR160/050	56C
					MR160/140	143/145TC
3.17	3,100	27.986	869	C302_0280	MR160/050	56C
					MR160/140	143/145TC
					MR200/180	182/184TC
4.50	4,388	27.857	1,490	C402_0280	MR160/050	56C
					MR160/140	143/145TC
5.00	4,872	27.857	1,490	C402_0280	MR200/180	182/184TC
11.33	11,344	28.636	3,411	C712_0290	MR200/180	182/184TC
17.69	17,716	28.636	3,411	C712_0290	MR250/210	213/215TC
					MR300/250	254/256TC
33.21	31,889	27.467	4,587	C812_0270	MR300/250	254/256TC
					MR300/280	284/286TC
50.44	50,495	28.631	5,737	C912_0290	MR300/180	182/184TC
					MR300/210	213/215TC
					MR300/250	254/256TC
					MR300/280	284/286TC
53.09	53,148	28.631	5,737	C912_0290	MR350/320	324/326TC

55 RPM Output (Approximate)

0.49	531	31.256	303	C002_0310	MR160/050	56C
0.98	1,063	31.071	542	C102_0310	MR160/050	56C
1.65	1,772	30.692	666	C202_0310	MR160/050	56C
					MR160/140	143/145TC
2.86	3,100	31.040	900	C302_0310	MR160/050	56C
					MR160/140	143/145TC
4.22	4,602	31.231	1,756	C502_0310	MR160/050	56C
					MR160/140	143/145TC
34.03	38,232	32.134	5,962	C912_0320	MR300/180	182/184TC
					MR300/210	213/215TC
					MR300/250	254/256TC
					MR300/280	284/286TC

C Series: INLINE — Solid Shaft Output

* Thermal HP Limit

Base Module Size	C0	C1	C2	C3	C4	C5	C6	C7	C8	C9
HP Limit	2.95	5.36	7.38	12.34	14.75	20.12	29.50	40.23	53.63	67.05

C Series: INLINE — Solid Shaft Output

1750 RPM Input		Nominal Ratio	Overhung Load Output Shaft ¹⁾ (lbs.)	Part Number Codes (in blue)		
Input HP	Output Torque (in. lbs.)			Base Module	Motor Adapter/ NEMA Motor	Compatible NEMA C-Frame ²⁾ with Designated Motor Adapter
50 RPM Output (Approximate)						
0.43	531	35.028	315	C002_0350	MR160/050	56C
0.87	1,063	35.065	564	C102_0350	MR160/050	56C
1.44	1,772	35.179	697	C202_0350	MR160/050	56C
					MR160/140	143/145TC
2.53	3,100	35.028	937	C302_0350	MR160/050	56C
					MR160/140	143/145TC
4.22	5,158	35.000	1,824	C502_0350	MR160/050	56C
					MR160/140	143/145TC
5.79	7,086	35.000	1,824	C502_0350	MR200/180	182/184TC
					MR250/210	213/215TC
7.37	8,714	33.797	3,605	C712_0340	MR200/180	182/184TC
8.00	9,751	34.872	2,649	C612_0350	MR200/180	182/184TC
9.45	11,515	34.872	2,649	C612_0350	MR250/180	182/184TC
					MR250/210	213/215TC
13.00	15,356	33.797	3,605	C712_0340	MR250/180	182/184TC
					MR250/210	213/215TC
15.85	18,615	33.585	4,905	C812_0340	MR250/180	182/184TC
					MR250/210	213/215TC
17.99	21,259	33.797	3,605	C712_0340	MR300/210	213/215TC
					MR300/250	254/256TC
19.95	24,641	35.333	4,989	C812_0350	MR250/180	182/184TC
					MR250/210	213/215TC
25.81	31,889	35.333	4,989	C812_0350	MR300/250	254/256TC
					MR300/210	213/215TC
28.20	33,114	33.585	4,905	C812_0340	MR300/250	254/256TC
					MR300/280	284/286TC
					MR300/180	182/184TC
41.49	52,231	36.005	6,192	C912_0360	MR300/210	213/215TC
					MR300/250	254/256TC
					MR300/280	284/286TC

1) Overhung Load is measured at the center of the shaft extension.

2) Motor HP for TEFC NEMA C-Frame @ 1750 RPM

Order Code	050	140	180	210	250	280	320	360
C-Frame	56C	143/145TC	182/184TC	213/215TC	254/256TC	284/286TC	324/326TC	364/365TC
HP	1/4 to 1-1/2	1, 1-1/2, 2	3, 5	7-1/2, 10	15, 20	25, 30	40, 50	60, 75

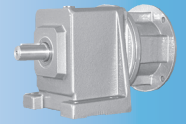

Selection Data

1750 RPM Input		Nominal Ratio	Overhung Load Output Shaft ¹⁾ (lbs.)	Part Number Codes (in blue)		
Input HP	Output Torque (in. lbs.)			Base Module	Motor Adapter/ NEMA Motor	Compatible NEMA C-Frame ²⁾ with Designated Motor Adapter
45 RPM Output (Approximate)						
0.35	531	41.774	427	C002_0420	MR140/050	56C
0.73	1,063	41.567	597	C102_0420	MR160/050	56C
1.24	1,772	40.850	733	C202_0410	MR160/050	56C
					MR160/140	143/145TC
2.14	3,100	41.354	990	C302_0410	MR160/050	56C
					MR160/140	143/145TC
2.84	4,141	41.751	1,705	C402_0420	MR160/050	56C
					MR160/140	143/145TC
3.34	4,872	41.751	1,705	C402_0420	MR200/180	182/184TC
5.47	7,530	39.396	2,759	C612_0390	MR200/180	182/184TC
6.42	9,201	41.016	3,845	C712_0410	MR200/180	182/184TC
7.85	10,812	39.396	2,759	C612_0390	MR250/180	182/184TC
11.26	16,144	41.016	3,845	C712_0410	MR250/180	182/184TC
					MR250/210	213/215TC
12.94	18,554	41.016	3,845	C712_0410	MR300/210	213/215TC
14.04	19,603	39.938	5,197	C812_0400	MR250/180	182/184TC
					MR250/210	213/215TC
23.56	32,904	39.938	5,197	C812_0400	MR300/210	213/215TC
					MR300/250	254/256TC
28.20	38,747	39.298	6,375	C912_0390	MR300/180	182/184TC
					MR300/210	213/215TC
					MR300/250	254/256TC
					MR300/280	284/286TC

C Series: INLINE — Solid Shaft Output

40 RPM Output (Approximate)						
0.33	531	46.815	347	C002_0470	MR140/050	56C
0.65	1,063	46.909	621	C102_0470	MR160/050	56C
1.08	1,772	46.822	767	C202_0470	MR160/050	56C
					MR160/140	143/145TC
1.90	3,100	46.667	1,031	C302_0470	MR160/050	56C
					MR160/140	143/145TC
2.84	4,629	46.667	1,770	C402_0470	MR160/050	56C
					MR160/140	143/145TC
7.37	12,071	46.818	4,019	C712_0470	MR200/180	182/184TC
10.82	17,716	46.818	4,019	C712_0470	MR250/180	182/184TC
					MR250/210	213/215TC

* Thermal HP Limit

Base Module Size	C0	C1	C2	C3	C4	C5	C6	C7	C8	C9
HP Limit	2.95	5.36	7.38	12.34	14.75	20.12	29.50	40.23	53.63	67.05

C Series: INLINE — Solid Shaft Output

1750 RPM Input		Nominal Ratio	Overhung Load Output Shaft ¹⁾ (lbs.)	Part Number Codes (in blue)		
Input HP	Output Torque (in. lbs.)			Base Module	Motor Adapter/ NEMA Motor	Compatible NEMA C-Frame ²⁾ with Designated Motor Adapter
40 RPM Output (Approximate) Continued						
15.85	25,241	45.538	5,429	C812_0460	MR250/180	182/184TC
					MR250/210	213/215TC
20.03	31,889	45.538	5,429	C812_0460	MR300/210	213/215TC
					MR300/250	254/256TC
33.29	53,148	45.655	6,702	C912_0460	MR300/180	182/184TC
					MR300/210	213/215TC
					MR300/250	254/256TC
					MR300/280	284/286TC
35 RPM Output (Approximate)						
0.30	531	49.944	355	C002_0500	MR140/050	56C
1.03	1,772	49.227	780	C202_0490	MR160/050	56C
1.78	3,100	49.745	1,053	C302_0500	MR160/050	56C
					MR160/140	143/145TC
2.43	4,270	50.192	1,813	C402_0500	MR160/050	56C
					MR160/140	143/145TC
2.84	4,942	49.821	2,051	C502_0500	MR160/050	56C
					MR160/140	143/145TC
4.07	7,086	49.821	2,051	C502_0500	MR200/180	182/184TC
12.13	21,259	50.845	4,131	C713_0510	MR250/180	182/184TC
					MR250/210	213/215TC
15.22	25,789	49.176	5,570	C813_0490	MR250/180	182/184TC
					MR250/210	213/215TC
30 RPM Output (Approximate)						
0.27	531	55.972	368	C002_0560	MR140/050	56C
0.90	1,772	56.424	816	C202_0560	MR160/050	56C
1.58	3,100	56.136	1,096	C302_0560	MR160/050	56C
					MR160/140	143/145TC
2.43	4,773	56.101	1,882	C402_0560	MR160/050	56C
					MR160/140	143/145TC
2.84	5,538	55.833	2,131	C502_0560	MR160/050	56C
					MR160/140	143/145TC
3.63	7,086	55.833	2,131	C502_0560	MR200/180	182/184TC
5.47	10,534	55.111	3,086	C612_0550	MR200/180	182/184TC
5.98	11,515	55.111	3,086	C612_0550	MR250/180	182/184TC
6.42	12,746	56.818	4,286	C712_0570	MR200/180	182/184TC

1) Overhung Load is measured at the center of the shaft extension.

2) Motor HP for TEFC NEMA C-Frame @ 1750 RPM

Order Code	050	140	180	210	250	280	320	360
C-Frame	56C	143/145TC	182/184TC	213/215TC	254/256TC	284/286TC	324/326TC	364/365TC
HP	1/4 to 1-1/2	1, 1-1/2, 2	3, 5	7-1/2, 10	15, 20	25, 30	40, 50	60, 75

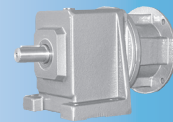

Selection Data

1750 RPM Input		Nominal Ratio	Overhung Load Output Shaft ¹⁾ (lbs.)	Part Number Codes (in blue)		
Input HP	Output Torque (in. lbs.)			Base Module	Motor Adapter/ NEMA Motor	Compatible NEMA C-Frame ²⁾ with Designated Motor Adapter

30 RPM Output (Approximate) Continued

8.92	17,716	56.818	4,286	C712_0570	MR250/180	182/184TC
					MR250/210	213/215TC
14.04	26,581	54.154	5,752	C812_0540	MR250/180	182/184TC
					MR250/210	213/215TC
16.84	31,889	54.154	5,752	C812_0540	MR300/210	213/215TC
					MR300/250	254/256TC
27.23	53,148	55.833	7,167	C912_0560	MR300/180	182/184TC
					MR300/210	213/215TC
					MR300/250	254/256TC
					MR300/280	284/286TC

28 RPM Output (Approximate)

5.87	12,844	63.462	3,234	C613_0630	MR200/180	182/184TC
15.22	34,593	65.963	6,143	C813_0660	MR250/180	182/184TC
					MR250/210	213/215TC

22 RPM Output (Approximate)

0.65	1,772	79.589	916	C203_0800	MR160/050	56C
1.75	4,872	80.810	2,125	C403_0810	MR160/050	56C
					MR160/140	143/145TC
2.55	7,086	80.596	2,408	C503_0810	MR160/050	56C
					MR160/140	143/145TC
6.54	17,879	79.339	6,533	C813_0790	MR200/180	182/184TC
6.54	18,245	80.965	4,824	C713_0810	MR200/180	182/184TC
7.74	21,259	79.734	4,799	C713_0800	MR250/180	182/184TC
13.67	36,804	78.133	6,500	C813_0780	MR250/180	182/184TC
					MR250/210	213/215TC
15.22	40,763	77.728	8,003	C913_0780	MR250/180	182/184TC
					MR250/210	213/215TC

20 RPM Output (Approximate)

0.56	1,772	91.225	945	C203_0910	MR160/050	56C
1.57	4,872	90.323	2,183	C403_0900	MR160/050	56C
					MR160/140	143/145TC
2.28	7,086	90.323	2,475	C503_0900	MR160/050	56C
					MR160/140	143/145TC
3.76	11,515	88.778	3,600	C613_0890	MR200/180	182/184TC
6.54	20,466	90.821	6,750	C813_0910	MR200/180	182/184TC
10.35	31,889	89.441	6,750	C813_0890	MR250/180	182/184TC
					MR250/210	213/215TC

C Series: INLINE — Solid Shaft Output

C Series: INLINE — Solid Shaft Output

1750 RPM Input		Nominal Ratio	Overhung Load Output Shaft ¹⁾ (lbs.)	Part Number Codes (in blue)		
Input HP	Output Torque (in. lbs.)			Base Module	Motor Adapter/ NEMA Motor	Compatible NEMA C-Frame ²⁾ with Designated Motor Adapter
18 RPM Output (Approximate)						
3.82	12,844	97.634	3,600	C613_0980	MR200/180	182/184TC
10.74	37,204	100.511	6,750	C813_1010	MR250/180	182/184TC
					MR250/210	213/215TC
16 RPM Output (Approximate)						
0.28	1,063	111.091	765	C103_1110	MR140/050	56C
0.47	1,772	109.206	945	C203_1090	MR160/050	56C
0.83	3,100	108.213	1,271	C303_1080	MR160/050	56C
1.31	4,872	107.714	2,183	C403_1080	MR160/050	56C
					MR160/140	143/145TC
4.66	17,716	110.455	4,950	C713_1100	MR250/180	182/184TC
6.54	24,243	107.578	6,750	C813_1080	MR200/180	182/184TC
8.74	31,889	105.943	6,750	C813_1060	MR250/180	182/184TC
					MR250/210	213/215TC
13.97	53,148	110.434	8,325	C913_1100	MR250/180	182/184TC
					MR250/210	213/215TC
13 RPM Output (Approximate)						
0.21	1,062	137.338	764	C103_1370	MR140/050	56C
0.36	1,770	137.786	944	C203_1380	MR140/050	56C
0.38	1,772	136.027	945	C203_1360	MR160/050	56C
0.63	3,098	137.192	1,270	C303_1370	MR140/050	56C
0.66	3,100	135.441	1,271	C303_1350	MR160/050	56C
					MR160/140	143/145TC
1.52	7,086	135.333	2,475	C503_1350	MR160/140	143/145TC
2.34	11,506	136.581	3,597	C613_1370	MR200/180	182/184TC
2.48	11,515	134.838	3,600	C613_1350	MR160/050	56C
					MR160/140	143/145TC
4.59	20,942	132.371	4,950	C713_1320	MR200/180	182/184TC
4.73	21,259	130.359	4,950	C713_1300	MR250/180	182/184TC
6.54	31,186	138.389	6,750	C813_1380	MR200/180	182/184TC
6.79	31,889	136.286	6,750	C813_1360	MR250/180	182/184TC
8.33	37,204	129.541	6,750	C813_1300	MR250/180	182/184TC
					MR250/210	213/215TC

1) Overhung Load is measured at the center of the shaft extension.

2) Motor HP for TEFC NEMA C-Frame @ 1750 RPM

Order Code	050	140	180	210	250	280	320	360
C-Frame	56C	143/145TC	182/184TC	213/215TC	254/256TC	284/286TC	324/326TC	364/365TC
HP	1/4 to 1-1/2	1, 1-1/2, 2	3, 5	7-1/2, 10	15, 20	25, 30	40, 50	60, 75

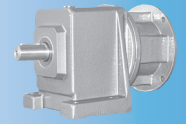

Selection Data

1750 RPM Input		Nominal Ratio	Overhung Load Output Shaft ¹⁾ (lbs.)	Part Number Codes (in blue)		
Input HP	Output Torque (in. lbs.)			Base Module	Motor Adapter/ NEMA Motor	Compatible NEMA C-Frame ²⁾ with Designated Motor Adapter
10 RPM Output (Approximate)						
5.19	31,889	178.359	6,750	C813_1780	MR200/180	182/184TC
8.76	53,148	176.097	8,325	C913_1760	MR250/180	182/184TC
					MR250/210	213/215TC
9.5 RPM Output (Approximate)						
0.16	1,062	183.727	764	C103_1840	MR140/050	56C
0.27	1,770	183.387	944	C203_1830	MR140/050	56C
0.28	1,772	181.046	945	C203_1810	MR160/050	56C
					MR160/140	143/145TC
0.47	3,098	182.778	1270	C303_1830	MR140/050	56C
0.50	3,100	180.444	1,271	C303_1800	MR160/050	56C
0.78	4,872	180.444	2,183	C403_1800	MR160/050	56C
2.72	17,701	180.584	4946	C713_1810	MR250/180	182/184TC, 213/215TC
					MR250/210	
2.68	17,701	183.371	4946	C713_1830	MR200/180	182/184TC
8 RPM Output (Approximate)						
0.23	1,772	220.995	945	C203_2210	MR140/050	56C
0.39	3,098	219.867	1270	C303_2200	MR140/050	56C
0.41	3,100	217.061	1,271	C303_2170	MR160/050	56C
0.65	4,872	216.925	2,183	C403_2170	MR160/050	56C
0.95	7,086	215.889	2,475	C503_2160	MR160/050	56C
1.57	11,515	213.096	3,600	C613_2130	MR160/050	56C
					MR160/140	143/145TC
2.24	17,701	219.156	4946	C713_2190	MR250/180	182/184TC, 213/215TC
					MR250/210	
2.21	17,701	222.538	4946	C713_2230	MR200/180	182/184TC
4.36	31,889	212.103	6,750	C813_2120	MR200/180	182/184TC
7.16	53,148	215.357	8,325	C913_2150	MR250/180	182/184TC

C Series: INLINE — Solid Shaft Output

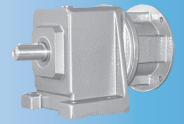

Dimensional Data

Optional Output Flanges

For "F" Round Output Flange Units Only

(Note: optional flanges are not available on all sizes)

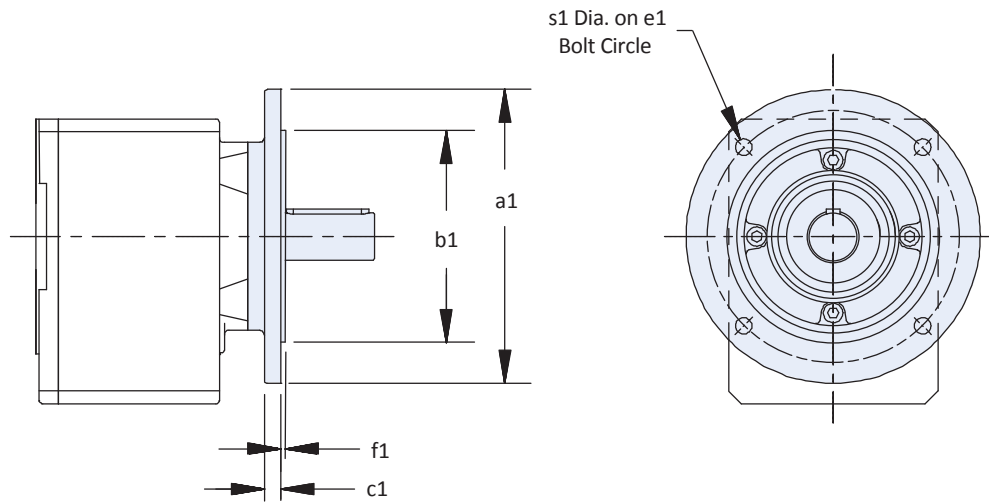

Table 1 Flange Dimensions (Inches) – Standard and Optional

Base Module	Flange Size	a1	b1	c1	e1	f1	s1
C0	120	4.724	3.150				
	140	5.512	3.740	+0.001/-0.0004	0.39	4.53	0.12
	160*	6.300	4.331			5.12	0.35
C1	140	5.512	3.740		0.32	4.53	0.35
	160	6.300	4.331	+0.001/-0.0004	0.39	5.12	0.14
	200*	7.874	5.118		0.47	6.50	0.43
C2	160	6.300	4.331		0.39	5.12	0.14
	200*	7.874	5.118	+0.001/-0.0004	0.47	6.50	0.14
	250	9.843	7.087		0.47	8.46	0.16
C3	160	6.300	4.331		0.39	5.12	0.14
	200	7.874	5.118	+0.001/-0.0004	0.47	6.50	0.14
	250*	9.843	7.087		0.47	8.46	0.16
C4	200	7.874	5.118	+0.001/-0.0004		6.50	0.43
	250*	9.843	7.087	+0.001/-0.0004	0.55	8.46	0.16
	300	11.811	9.055	+0.001/-0.001		10.43	0.55
C5	250	9.843	7.087	+0.001/-0.0004	0.55	8.46	
	300*	11.811	9.055	+0.001/-0.001	0.63	10.43	0.16
C6	300*	11.811	9.055	+0.001/-0.001	0.67	10.43	0.16
C7	350*	13.780	9.842	+0.000/-0.001	0.71	11.81	0.20
C8	350	13.780	9.842		0.71	11.81	
	400*	15.748	11.811	+0.000/-0.001	0.79	13.78	0.20
	450	17.717	13.780		0.79	15.75	
C9	450*	17.717	13.780	+0.000/-0.001	0.91	15.75	0.20

* This is the standard flange and will be shipped unless otherwise specified. Optional flanges are not available for all sizes.

Please contact STÖBER for ordering assistance.

C Series: INLINE — Solid Shaft Output

C Series: INLINE — Solid Shaft Output

"F" Round Output Flange —

C002F thru C503F

Optional Output Flanges available on most models, see page <?> for details.

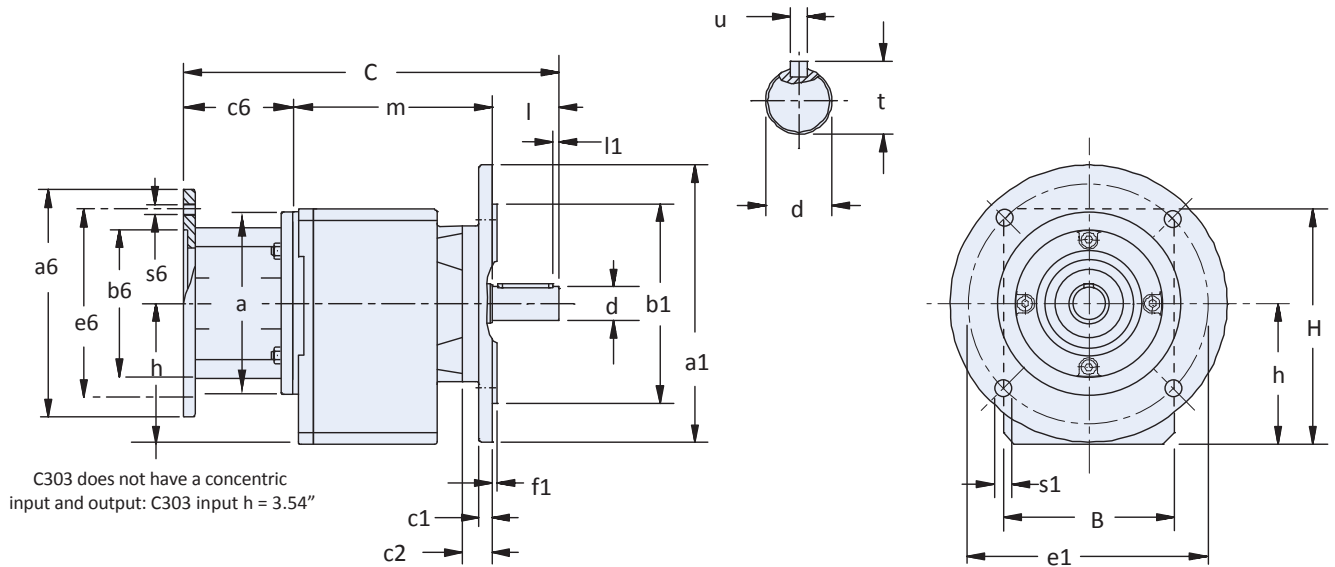

C612F thru C913F

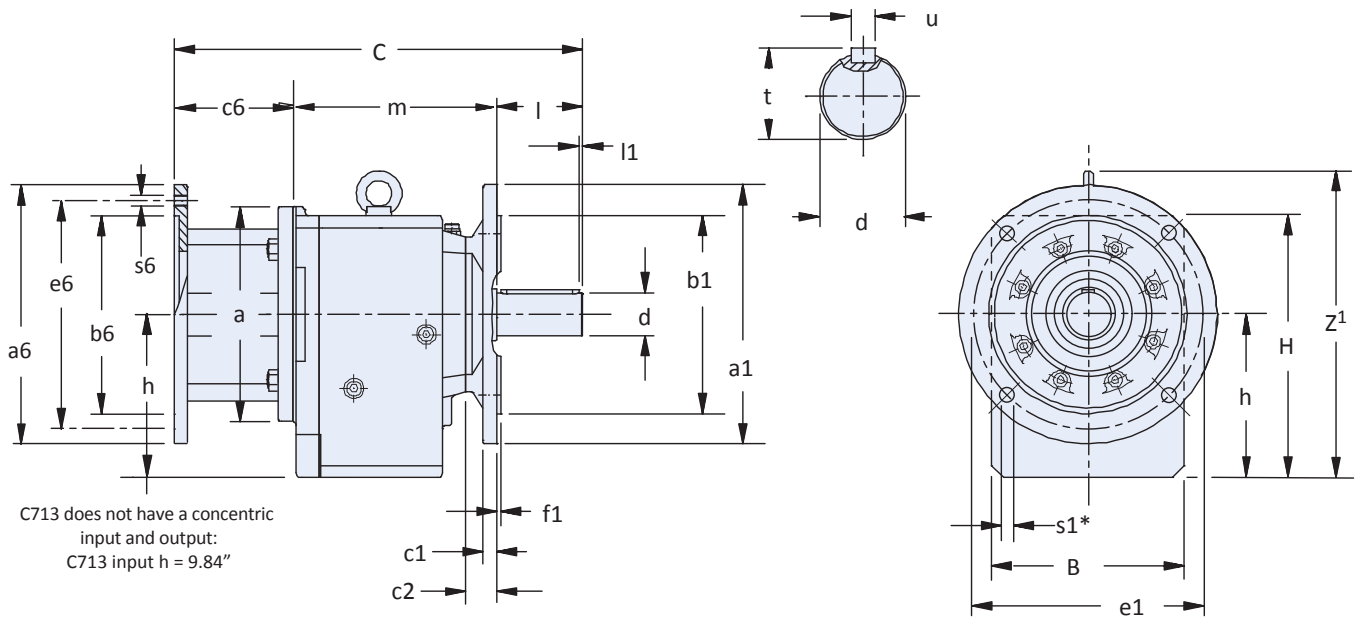

* NOTE: Instead of 4 holes as shown in the drawing, the C912 and C913 output flange has 8 \varnothing "s1" mounting holes on "e1" bolt circle (located 22.5° from horizontal).

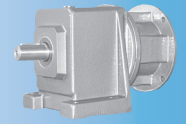

Dimensional Data

Table 1 C Series Unit Dimensions (Inches) – “F” Round Flange Housing

Base Module	a1*	B	b1	c1	c2	e1	f1	H	h	l	l1	s1	z ¹
C0	6.30	3.82	4.331	0.39	0.71	5.12	0.12	5.55	3.11	1.57	0.16	0.35	—
C1	7.87	5.12	5.118	0.47	0.83	6.50	0.14	6.89	3.94	1.97	0.16	0.43	—
C2	7.87	5.59	5.118	0.47	1.06	6.50	0.14	7.56	4.41	2.36	0.16	0.43	—
C3	9.84	6.06	7.087	0.47	1.06	8.46	0.16	8.35	5.00 ¹⁾	2.36	0.16	0.55	—
C4	9.84	7.01	7.087	0.55	1.10	8.46	0.16	9.55	5.61	3.15	0.16	0.55	—
C5	11.81	7.68	9.055	0.63	1.14	10.43	0.16	11.26	6.54	3.15	0.16	0.55	—
C6	11.81	8.86	9.055	0.67	1.42	10.43	0.16	11.97	7.44	3.94	0.20	0.55	14.01
C7	13.78	10.43	9.842	0.71	1.73	11.81	0.20	14.61	9.09 ¹⁾	4.72	0.20	0.71	17.00
C8	15.75	12.20	11.811	0.79	1.77	13.78	0.20	17.52	11.22	5.51	0.39	0.71	19.92
C9	17.72	14.37	13.780	0.91	1.97	15.75 ²⁾	0.20	20.63	13.15	6.69	0.39	0.71 ²⁾	23.39

* See page <?> for other available output flanges.

1) C303 and C713 do not have a concentric input and output. Refer to the h input height dimension on the drawing for these units.

2) C912 and C913 have 8 mounting holes in the output flange instead of 4 as shown in the drawing.

Table 2 C Series — Shaft Output (Carbon Steel)

(see page 126 for standard SS, and other optional outputs)

Base Module	Standard Shaft - inches			Optional Shaft - mm		
	d	t	u	d	t	u
C0	3/4	0.83	3/16x3/16x1-7/32	20k6	22.5	A6x6x32
C1	1	1.11	1/4x1/4x1-9/16	25k6	28	A8x7x40
C2	1-1/4	1.36	1/4x1/4x1-15/16	30k6	33	A8x7x50
C3	1-1/4	1.36	1/4x1/4x1-15/16	30k6	33	A8x7x50
C4	1-5/8	1.79	3/8x3/8x2-7/8	40k6	43	A12x8x70
C5	1-5/8	1.79	3/8x3/8x2-7/8	40k6	43	A12x8x70
C6	2-1/8	2.35	1/2x1/2x3-5/32	50k6	53.5	A14x9x90
C7	2-3/8	2.65	5/8x5/8x3-15/16	60m6	64	A18x11x100
C8	2-7/8	3.21	3/4x3/4x4-5/16	70m6	74.5	A20x12x125
C9	3-5/8	4.01	7/8x7/8x5-1/2	90m6	95	A25x14x140

Table 3 Motor Adapter Dimensions (Inches)

Motor Adapter	NEMA C-Flange	a	a6	b6	c6	e6	s6	Wt. lbs
MR140/050	56C	5.51	6.50	4.500	3.31	5.87	0.41	9
MR160/050	56C	6.30	6.50	4.500	3.86	5.87	0.41	16
MR160/140	143/145TC	7.87	9.00	8.500	4.80	7.25	0.55	23
MR200/180	182/184TC	9.84	9.00	8.500	5.31	7.25	0.55	36
MR250/180	182/184TC	11.81	9.00	8.500	6.50	7.25	0.57	75
MR250/210	213/215TC		9.00	8.500		7.25		
MR300/180	182/184TC	13.78	9.00	8.500	10.500	7.25	0.70	133
MR300/210	213/215TC		9.00	8.500		7.25		
MR300/250	254/256TC		9.00	8.500		7.25		
MR300/280	284/286TC	11.13	10.500	9.00				
MR350/320	324/326TC	13.78	13.37	12.500	7.09	11.00	0.70	133
MR350/360	364/365TC	13.37	12.500	7.09	11.00	0.70	133	

Table 4 C Series Unit Dimensions (Inches) – “MR” Motor Adapter

Base Module	MR140/050			MR160/050 MR160/140			MR200/180			MR250/180 MR250/210			MR300/180 MR300/210 MR300/250 MR300/280			MR350/320 MR350/360			Wt. lbs*
	C	l	m	C	l	m	C	l	m	C	l	m	C	l	m	C	l	m	
C002	9.37	1.57	4.49	10.08	1.57	4.65	—	—	—	—	—	—	—	—	—	—	—	—	18
C102	10.67	1.97	5.39	11.38	1.97	5.55	12.40	1.97	5.63	—	—	—	—	—	—	—	—	—	29
C103	12.13	1.97	6.85	—	—	—	—	—	—	—	—	—	—	—	—	—	—	—	34
C202	11.77	2.36	6.10	12.48	2.36	6.26	13.50	2.36	6.34	—	—	—	—	—	—	—	—	—	38
C203	13.23	2.36	7.56	14.17	2.36	7.95	—	—	—	—	—	—	—	—	—	—	—	—	45
C302	—	—	—	13.23	2.36	7.01	14.25	2.36	7.09	14.88	2.36	7.21	—	—	—	—	—	—	49
C303	13.98	2.36	8.31	14.92	2.36	8.70	—	—	—	—	—	—	—	—	—	—	—	—	56
C402	—	—	—	15.12	3.15	8.11	16.14	3.15	8.19	16.77	3.15	8.31	—	—	—	—	—	—	71
C403	—	—	—	16.81	3.15	9.80	—	—	—	—	—	—	—	—	—	—	—	—	78
C502	—	—	—	15.95	3.15	8.94	16.97	3.15	9.02	17.59	3.15	9.13	19.33	3.15	9.68	—	—	—	95
C503	—	—	—	17.64	3.15	10.63	—	—	—	—	—	—	—	—	—	—	—	—	111
C612	—	—	—	—	—	—	17.91	3.94	9.17	18.54	3.94	9.29	20.24	3.94	9.80	—	—	—	115
C613	—	—	—	18.62	3.94	10.82	20.35	3.94	11.61	—	—	—	—	—	—	—	—	—	159
C712	—	—	—	—	—	—	20.00	4.72	10.48	20.59	4.72	10.56	22.29	4.72	11.07	—	—	—	199
C713	—	—	—	—	—	—	22.40	4.72	12.88	23.38	4.72	13.35	—	—	—	—	—	—	221
C812	—	—	—	—	—	—	—	—	—	23.22	5.51	12.40	24.53	5.51	12.52	26.42	5.51	13.82	322
C813	—	—	—	—	—	—	25.04	5.51	14.73	26.02	5.51	15.20	—	—	—	—	—	—	342
C912	—	—	—	—	—	—	—	—	—	—	—	—	27.56	6.69	14.37	29.06	6.69	15.28	596
C913	—	—	—	—	—	—	—	—	—	27.87	6.69	15.87	—	—	—	—	—	—	678

* Weight is base unit only. MR weight must be added separately.

C Series: INLINE — Solid Shaft Output

C Series: INLINE — Solid Shaft Output

“G” Pilot Circle Diameter (PCD) Tapped Holes —

C002G thru C503G

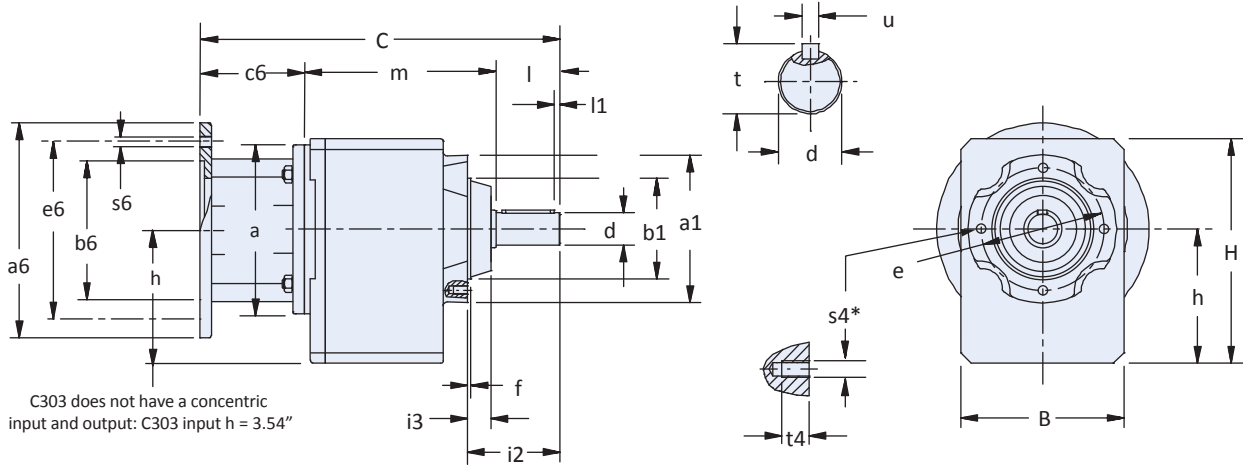

* NOTE: Instead of 4 holes as shown in the drawing, the C502/C503 has 8 holes located as shown in drawing below for C612G – C913G.

C612G thru C913G

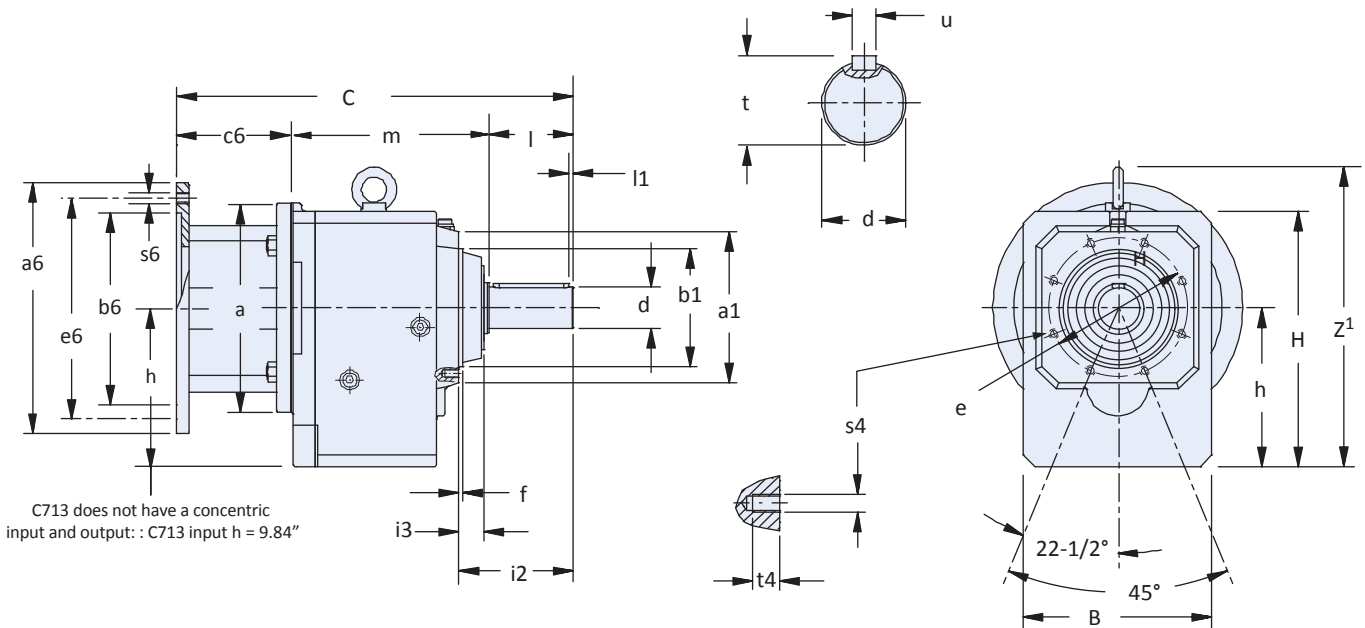

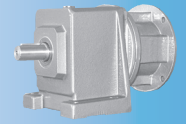

Dimensional Data

Table 1 C Series Unit Dimensions (Inches) – “G” Pilot Circle Diameter (PCD) Tapped Holes

Base Module	a1	B	b1	e	f	H	h	i2	i3	l	l1	t4	s4	Z1
C0	3.43	3.82	2.165	2.95	0.12	5.55	3.11	2.28	0.55	1.57	0.16	0.39	M6x1	—
C1	4.72	5.12	3.150	3.94	0.12	6.89	3.94	2.80	0.67	1.97	0.16	0.51	M6x1	—
C2	5.51	5.59	3.740	4.53	0.12	7.56	4.41	3.43	0.87	2.36	0.16	0.51	M8x1.25	—
C3	5.51	6.06	3.740	4.53	0.12	8.35	5.00 ¹⁾	3.43	0.87	2.36	0.16	0.51	M8x1.25	—
C4	6.30	7.01	4.331	5.12	0.14	9.55	5.61	4.25	0.87	3.15	0.16	0.63	M10x1.5	—
C5	7.56	7.68	5.118	6.50 ²⁾	0.14	11.26	6.54	4.29	0.91	3.15	0.16	0.63	M10x1.5	—
C6	7.09	8.86	5.512	6.50	0.20	11.97	7.44	5.35	1.18	3.94	0.20	0.63	M10x1.5	14.01
C7	7.68	10.43	6.102	7.28	0.31	14.61	9.09 ¹⁾	6.46	1.46	4.72	0.20	0.75	M12x1.75	17.00
C8	8.90	12.20	7.283	8.46	0.20	17.52	11.22	7.28	1.46	5.51	0.39	0.75	M12x1.75	19.92
C9	11.02	14.37	9.055	10.43	0.20	20.63	13.15	8.66	1.65	6.69	0.39	1.02	M16x2	23.39

1) C303 and C713 do not have a concentric input and output. Refer to the h input height dimension on the drawing for these units.
 2) C502 and C503 have 8 mounting holes in the output flange instead of 4 as shown in the drawing.

Table 2 C Series — Shaft Output (Carbon Steel)

(see page 126 for standard SS, and other optional outputs)

Base Module	Standard Shaft - inches			Optional Shaft - mm		
	d	t	u	d	t	u
C0	3/4	0.83	3/16x3/16x1-7/32	20k6	22.5	A6x6x32
C1	1	1.11	1/4x1/4x1-9/16	25k6	28	A8x7x40
C2	1-1/4	1.36	1/4x1/4x1-15/16	30k6	33	A8x7x50
C3	1-1/4	1.36	1/4x1/4x1-15/16	30k6	33	A8x7x50
C4	1-5/8	1.79	3/8x3/8x2-7/8	40k6	43	A12x8x70
C5	1-5/8	1.79	3/8x3/8x2-7/8	40k6	43	A12x8x70
C6	2-1/8	2.35	1/2x1/2x3-5/32	50k6	53.5	A14x9x90
C7	2-3/8	2.65	5/8x5/8x3-15/16	60m6	64	A18x11x100
C8	2-7/8	3.21	3/4x3/4x4-5/16	70m6	74.5	A20x12x125
C9	3-5/8	4.01	7/8x7/8x5-1/2	90m6	95	A25x14x140

Table 3 Motor Adapter Dimensions (Inches)

Motor Adapter	NEMA C-Flange	a	a6	b6	c6	e6	s6	Wt. lbs
MR140/050	56C	5.51	6.50	4.500	3.31	5.87	0.41	9
MR160/050	56C	6.30	6.50	4.500	3.86	5.87	0.41	16
MR160/140	143/145TC	7.87	9.00	8.500	4.80	7.25	0.55	23
MR200/180	182/184TC	9.84	9.00	8.500	5.31	7.25	0.55	36
MR250/210	213/215TC	11.81	9.00	8.500	6.50	7.25	0.57	75
MR300/180	182/184TC	11.81	9.00	8.500	6.50	7.25	0.57	75
MR300/210	213/215TC	11.81	9.00	8.500	6.50	7.25	0.57	75
MR300/250	254/256TC	11.13	10.500	9.00	7.25	9.00	0.70	133
MR300/280	284/286TC	13.78	13.37	12.500	7.09	11.00	0.70	133
MR350/320	324/326TC	13.78	13.37	12.500	7.09	11.00	0.70	133
MR350/360	364/365TC	13.78	13.37	12.500	7.09	11.00	0.70	133

Table 4 C Series Unit Dimensions (Inches) – “MR” Motor Adapter

Base Module	MR140/050			MR160/050 MR160/140			MR200/180			MR250/180 MR250/210			MR300/180 MR300/210 MR300/250 MR300/280			MR350/320 MR350/360			Wt. lbs*
	C	l	m	C	l	m	C	l	m	C	l	m	C	l	m	C	l	m	
C002	9.37	1.57	4.49	10.08	1.57	4.65	—	—	—	—	—	—	—	—	—	—	—	—	18
C102	10.67	1.97	5.39	11.38	1.97	5.55	12.40	1.97	5.63	—	—	—	—	—	—	—	—	—	29
C103	12.13	1.97	6.85	—	—	—	—	—	—	—	—	—	—	—	—	—	—	—	34
C202	11.77	2.36	6.10	12.48	2.36	6.26	13.50	2.36	6.34	—	—	—	—	—	—	—	—	—	38
C203	13.23	2.36	7.56	14.17	2.36	7.95	—	—	—	—	—	—	—	—	—	—	—	—	45
C302	—	—	—	13.23	2.36	7.01	14.25	2.36	7.09	14.88	2.36	7.21	—	—	—	—	—	—	49
C303	13.98	2.36	8.31	14.92	2.36	8.70	—	—	—	—	—	—	—	—	—	—	—	—	56
C402	—	—	—	15.12	3.15	8.11	16.14	3.15	8.19	16.77	3.15	8.31	—	—	—	—	—	—	71
C403	—	—	—	16.81	3.15	9.80	—	—	—	—	—	—	—	—	—	—	—	—	78
C502	—	—	—	15.95	3.15	8.94	16.97	3.15	9.02	17.59	3.15	9.13	19.33	3.15	9.68	—	—	—	95
C503	—	—	—	17.64	3.15	10.63	—	—	—	—	—	—	—	—	—	—	—	—	111
C612	—	—	—	—	—	—	17.91	3.94	9.17	18.54	3.94	9.29	20.24	3.94	9.80	—	—	—	115
C613	—	—	—	18.62	3.94	10.82	20.35	3.94	11.61	—	—	—	—	—	—	—	—	—	159
C712	—	—	—	—	—	—	20.00	4.72	10.48	20.59	4.72	10.56	22.29	4.72	11.07	—	—	—	199
C713	—	—	—	—	—	—	22.40	4.72	12.88	23.38	4.72	13.35	—	—	—	—	—	—	221
C812	—	—	—	—	—	—	—	—	—	23.22	5.51	12.40	24.53	5.51	12.52	26.42	5.51	13.82	322
C813	—	—	—	—	—	—	25.04	5.51	14.73	26.02	5.51	15.20	—	—	—	—	—	—	342
C912	—	—	—	—	—	—	—	—	—	—	—	—	27.56	6.69	14.37	29.06	6.69	15.28	596
C913	—	—	—	—	—	—	—	—	—	27.87	6.69	15.87	—	—	—	—	—	—	678

* Weight is base unit only. MR weight must be added separately.

C Series: INLINE — Solid Shaft Output

C Series: INLINE — Solid Shaft Output

“N” Foot Mount —

C002N thru C503N

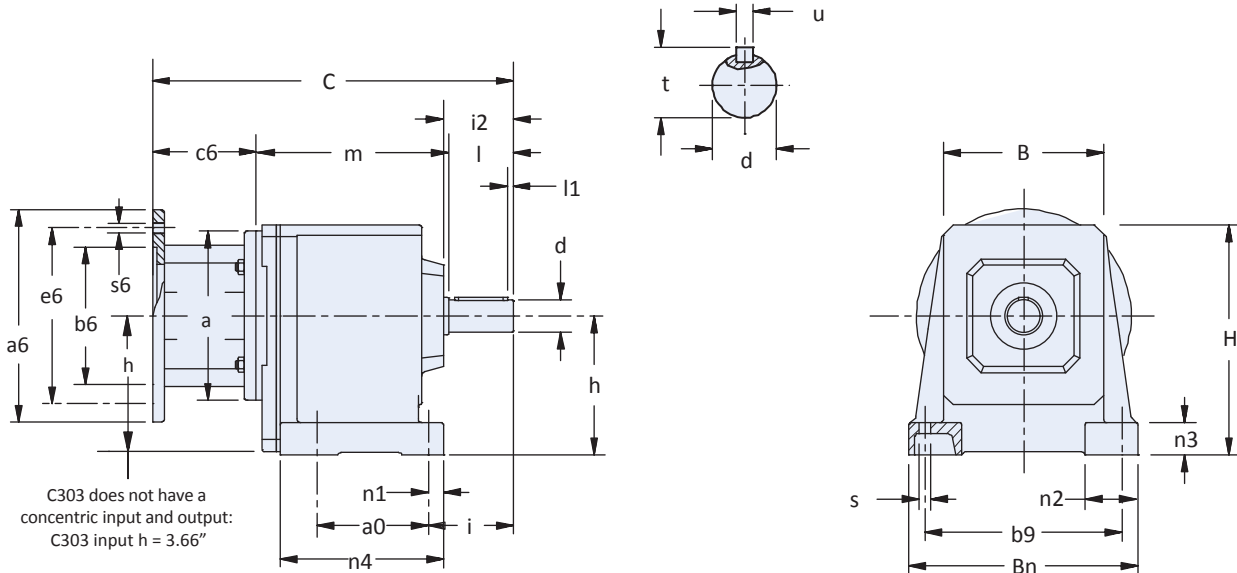

C612N thru C913N

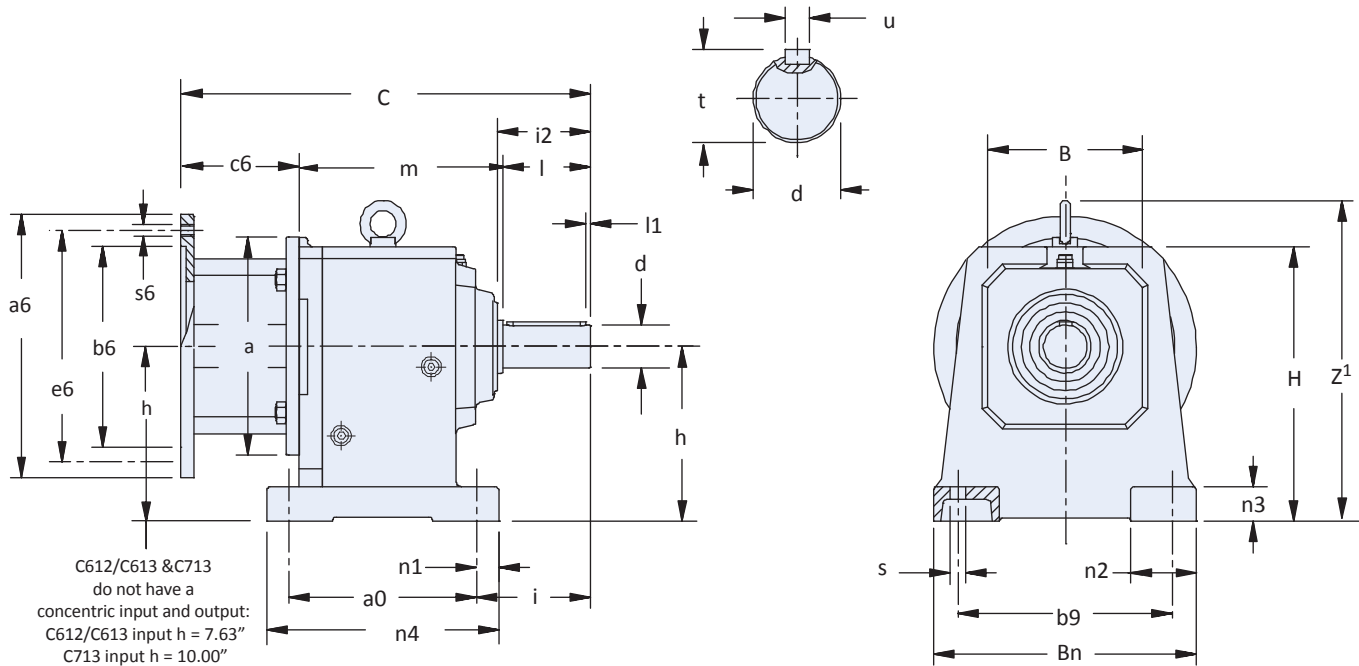

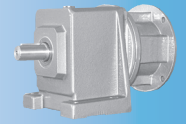

Dimensional Data

Table 1 C Series Unit Dimensions (Inches) – “N” Foot Mount Housing

Base Module	a0	B	Bn	b9	H	h	i	i2	l	l1	n1	n2	n3	n4	s	Z1
C0	2.44	3.62	5.20	4.33	5.67	3.23	2.17	1.73	1.57	0.16	0.43	1.38	0.79	3.74	0.28	—
C1	2.76	4.88	6.93	5.91	6.97	4.02	2.64	2.13	1.97	0.16	0.51	1.65	0.98	4.65	0.35	—
C2	3.35	5.43	7.87	6.69	7.68	4.53	3.11	2.56	2.36	0.16	0.55	1.97	1.18	5.31	0.43	—
C3	4.13	5.91	8.46	7.28	8.46	5.12 ¹⁾	3.11	2.56	2.36	0.16	0.55	1.97	1.18	6.06	0.43	—
C4	4.33	6.89	10.04	8.66	9.65	5.71	4.13	3.39	3.15	0.16	0.75	2.36	1.38	7.09	0.55	—
C5	5.12	7.56	11.42	9.65	11.42	6.69	4.25	3.39	3.15	0.16	0.87	2.76	1.57	7.76	0.71	—
C6	8.46	6.97	11.81	9.65	12.40	7.87 ¹⁾	5.12	4.17	3.94	0.20	0.98	2.95	1.57	10.43	0.71	14.44
C7	9.25	7.56	14.37	11.81	14.76	9.25 ¹⁾	6.42	5.00	4.72	0.20	0.98	3.54	1.97	11.22	0.71	17.16
C8	11.81	8.78	17.13	13.39	17.72	11.42	7.48	5.83	5.51	0.39	1.14	3.74	2.17	14.17	0.87	20.12
C9	13.39	10.91	20.08	15.75	20.87	13.39	8.74	7.01	6.69	0.39	1.34	4.33	2.36	16.14	1.02	23.63

1) C303, C612/C613 and C713 do not have a concentric input and output. Refer to the h input height dimension on the drawing for these units.

Table 2 C Series — Shaft Output (Carbon Steel)

(see page 126 for standard SS, and other optional outputs)

Base Module	Standard Shaft - inches			Optional Shaft - mm		
	d	t	u	d	t	u
C0	3/4	0.83	3/16x3/16x1-7/32	20k6	22.5	A6x6x32
C1	1	1.11	1/4x1/4x1-9/16	25k6	28	A8x7x40
C2	1-1/4	1.36	1/4x1/4x1-15/16	30k6	33	A8x7x50
C3	1-1/4	1.36	1/4x1/4x1-15/16	30k6	33	A8x7x50
C4	1-5/8	1.79	3/8x3/8x2-7/8	40k6	43	A12x8x70
C5	1-5/8	1.79	3/8x3/8x2-7/8	40k6	43	A12x8x70
C6	2-1/8	2.35	1/2x1/2x3-5/32	50k6	53.5	A14x9x90
C7	2-3/8	2.65	5/8x5/8x3-15/16	60m6	64	A18x11x100
C8	2-7/8	3.21	3/4x3/4x4-5/16	70m6	74.5	A20x12x125
C9	3-5/8	4.01	7/8x7/8x5-1/2	90m6	95	A25x14x140

Table 3 Motor Adapter Dimensions (Inches)

Motor Adapter	NEMA C-Flange	a	a6	b6	c6	e6	s6	Wt. lbs
MR140/050	56C	5.51	6.50	4.500	3.31	5.87	0.41	9
MR160/050	56C	6.30	6.50	4.500	3.86	5.87	0.41	16
MR160/140	143/145TC	7.87	9.00	8.500	4.80	7.25	0.55	23
MR200/180	182/184TC	9.84	9.00	8.500	5.31	7.25	0.55	36
MR250/180	182/184TC	11.81	9.00	8.500	6.50	7.25	0.57	75
MR250/210	213/215TC		9.00	8.500		7.25		
MR300/180	182/184TC	13.78	9.00	8.500	11.13	7.25	0.70	133
MR300/210	213/215TC		9.00	8.500		7.25		
MR300/250	254/256TC		9.00	8.500		7.25		
MR300/280	284/286TC	13.37	11.13	10.500	7.09	9.00	0.70	133
MR350/320	324/326TC		13.78	13.37		12.500		
MR350/360	364/365TC	13.37	13.37	12.500	7.09	11.00	0.70	133

Table 4 C Series Unit Dimensions (Inches) – “MR” Motor Adapter

Base Module	MR140/050			MR160/050 MR160/140			MR200/180			MR250/180 MR250/210			MR300/180 MR300/210 MR300/250 MR300/280			MR350/320 MR350/360			Wt. lbs*
	C	l	m	C	l	m	C	l	m	C	l	m	C	l	m	C	l	m	
C002	9.37	1.57	4.49	10.08	1.57	4.65	—	—	—	—	—	—	—	—	—	—	—	—	18
C102	10.67	1.97	5.39	11.38	1.97	5.55	12.40	1.97	5.63	—	—	—	—	—	—	—	—	—	29
C103	12.13	1.97	6.85	—	—	—	—	—	—	—	—	—	—	—	—	—	—	—	34
C202	11.77	2.36	6.10	12.48	2.36	6.26	13.50	2.36	6.34	—	—	—	—	—	—	—	—	—	38
C203	13.23	2.36	7.56	14.17	2.36	7.95	—	—	—	—	—	—	—	—	—	—	—	—	45
C302	—	—	—	13.23	2.36	7.01	14.25	2.36	7.09	14.88	2.36	7.21	—	—	—	—	—	—	49
C303	13.98	2.36	8.31	14.92	2.36	8.70	—	—	—	—	—	—	—	—	—	—	—	—	56
C402	—	—	—	15.12	3.15	8.11	16.14	3.15	8.19	16.77	3.15	8.31	—	—	—	—	—	—	71
C403	—	—	—	16.81	3.15	9.80	—	—	—	—	—	—	—	—	—	—	—	—	78
C502	—	—	—	15.95	3.15	8.94	16.97	3.15	9.02	17.59	3.15	9.13	19.33	3.15	9.68	—	—	—	95
C503	—	—	—	17.64	3.15	10.63	—	—	—	—	—	—	—	—	—	—	—	—	111
C612	—	—	—	—	—	—	17.91	3.94	9.17	18.54	3.94	9.29	20.24	3.94	9.80	—	—	—	115
C613	—	—	—	18.62	3.94	10.82	20.35	3.94	11.61	—	—	—	—	—	—	—	—	—	159
C712	—	—	—	—	—	—	20.00	4.72	10.48	20.59	4.72	10.56	22.29	4.72	11.07	—	—	—	199
C713	—	—	—	—	—	—	22.40	4.72	12.88	23.38	4.72	13.35	—	—	—	—	—	—	221
C812	—	—	—	—	—	—	—	—	—	23.22	5.51	12.40	24.53	5.51	12.52	26.42	5.51	13.82	322
C813	—	—	—	—	—	—	25.04	5.51	14.73	26.02	5.51	15.20	—	—	—	—	—	—	342
C912	—	—	—	—	—	—	—	—	—	—	—	—	27.56	6.69	14.37	29.06	6.69	15.28	596
C913	—	—	—	—	—	—	—	—	—	27.87	6.69	15.87	—	—	—	—	—	—	678

* Weight is base unit only. MR weight must be added separately.

C Series: INLINE — Solid Shaft Output

“Q” Square Output Flange

C002Q thru C403Q

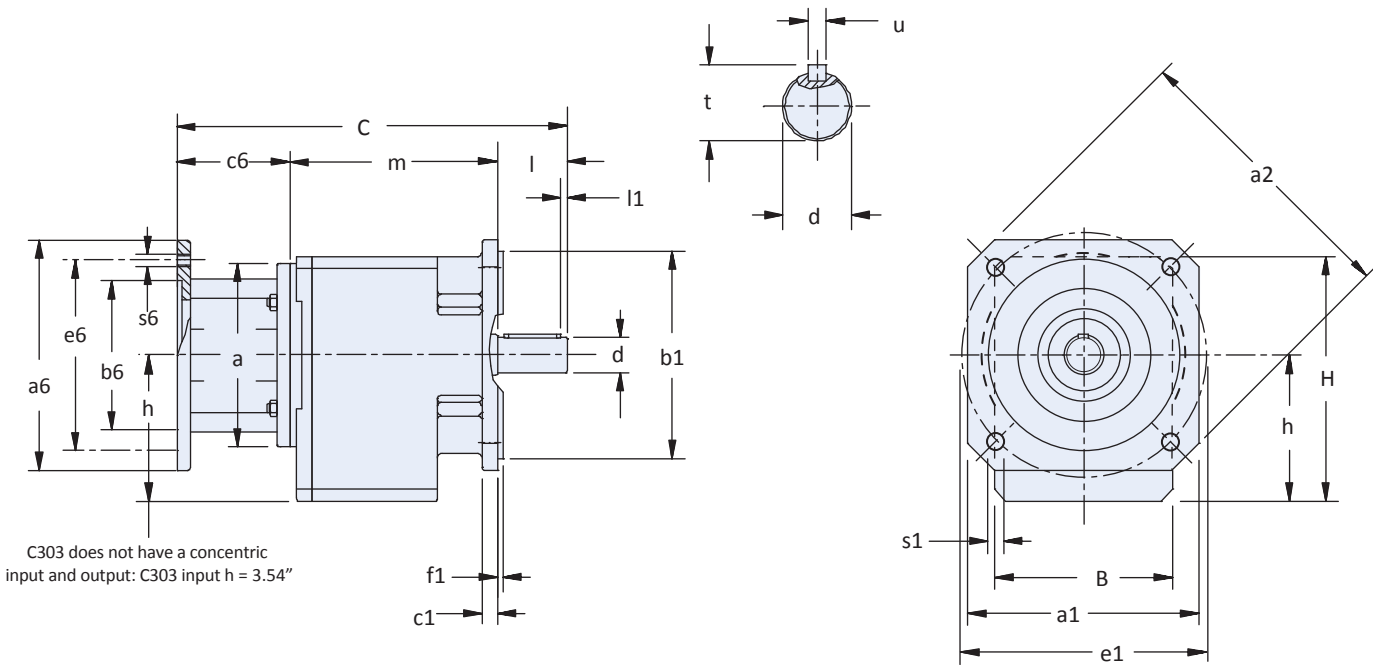

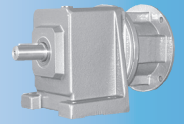

Dimensional Data

Table 1 C Series Unit Dimensions (Inches) – “Q” Square Flange Housing

Base Module	a1	a2	B	b1	c1	e1	f1	H	h	l	l1	s1
C0	4.88	6.30	3.82	4.33	0.35	5.12	0.14	5.55	3.11	1.57	0.16	0.35
C1	5.71	7.56	5.12	5.12	0.43	6.50	0.14	6.89	3.94	1.97	0.16	0.43
C2	5.71	7.56	5.59	5.12	0.43	6.50	0.14	7.56	4.41	2.36	0.16	0.43
C3	7.87	9.84	6.06	7.09	0.55	8.46	0.16	8.35	5.00 ¹⁾	2.36	0.16	0.55
C4	7.87	9.84	7.01	7.09	0.55	8.46	0.16	9.55	5.61	3.15	0.16	0.55

1) C303 does not have a concentric input and output. Refer to the h input height dimension on the drawing for these units.

Table 2 C Series — Shaft Output (Carbon Steel)

(see page 126 for standard SS, and other optional outputs)

Base Module	Standard Shaft - inches			Optional Shaft - mm		
	d	t	u	d	t	u
C0	3/4	0.83	3/16x3/16x1-7/32	20k6	22.5	A6x6x32
C1	1	1.11	1/4x1/4x1-9/16	25k6	28	A8x7x40
C2	1-1/4	1.36	1/4x1/4x1-15/16	30k6	33	A8x7x50
C3	1-1/4	1.36	1/4x1/4x1-15/16	30k6	33	A8x7x50
C4	1-5/8	1.79	3/8x3/8x2-7/8	40k6	43	A12x8x70

Table 3 Motor Adapter Dimensions (Inches)

Motor Adapter	NEMA C-Flange	a	a6	b6	c6	e6	s6	Wt. lbs
MR140/050	56C	5.51	6.50	4.500	3.31	5.87	0.41	9
MR160/050	56C	6.30	6.50	4.500	3.86	5.87	0.41	16
MR160/140	143/145TC	6.30	6.50	4.500	3.86	5.87	0.41	16
MR200/180	182/184TC	7.87	9.00	8.500	4.80	7.25	0.55	23
MR250/180	182/184TC	9.84	9.00	8.500	5.31	7.25	0.55	36
MR250/210	213/215TC	9.84	9.00	8.500	5.31	7.25	0.55	36

Table 4 C Series Unit Dimensions (Inches) – “MR” Motor Adapter

Base Module	MR140/050			MR160/050 MR160/140			MR200/180			MR250/180 MR250/210			Wt. lbs*
	C	l	m	C	l	m	C	l	m	C	l	m	
C002	9.37	1.57	4.49	10.08	1.57	4.65	—	—	—	—	—	—	18
C102	10.67	1.97	5.39	11.38	1.97	5.55	12.40	1.97	5.63	—	—	—	29
C103	12.13	1.97	6.85	—	—	—	—	—	—	—	—	—	34
C202	11.77	2.36	6.10	12.48	2.36	6.26	13.50	2.36	6.34	—	—	—	38
C203	13.23	2.36	7.56	14.17	2.36	7.95	—	—	—	—	—	—	45
C302	—	—	—	13.23	2.36	7.01	14.25	2.36	7.09	14.88	2.36	7.21	49
C303	13.98	2.36	8.31	14.92	2.36	8.70	—	—	—	—	—	—	56
C402	—	—	—	15.12	3.15	8.11	16.14	3.15	8.19	16.77	3.15	8.31	71
C403	—	—	—	16.81	3.15	9.8	—	—	—	—	—	—	78

* Weight is base unit only. MR weight must be added separately.

C Series: INLINE — Solid Shaft Output

F Series: OFFSET — Solid Shaft/Hollow Output

F Series Features

- Input rating up to 33 HP
- Ratio options: 4.3:1 — 552:1
- Output Torque capability up to 9743 lb-in
- NEMA input capabilities of 56C, 143/145TC, 182/184TC, 213/215TC
- Output bore diameters from 3/4" to 2"
- Housing style options: feet, flange or tapped holes

Compact size and flexibility make these gear drives a popular choice for applications that require high performance, efficiency, and durability. F Series gear drives are available with a wide selection of exact ratios and output speeds to eliminate the need for expensive and maintenance prone external input drives.

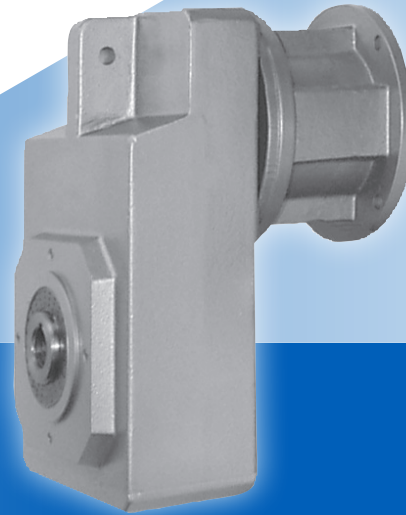

**SHIPS in
1 DAY!**
NO EXPEDITE FEE FOR 24
HOUR SERVICE

F Series Benefits

- No maintenance - totally enclosed with no breather to allow contaminants in or oil out
- Lubricated for life with Mobil oil
- Simple motor mounting and removal with Bowex coupling system
- Energy savings - up to 97% efficiency
- Easy installation and removal with our patented bushing system and any horizontal mounting position
- Reliability guaranteed with 3 year warranty
- Adaptability
- Durability - IP69K Certified to prevent water and dust ingress
- Assembled in USA
- Combine units to achieve slower speeds to meet your application needs

F Series Food & Corrosion Resistant Options

"F" Option for Food Duty Applications

- Totally enclosed unit — no breathers, maintenance free, lubricated for life
- Mobil SHC CIBUS 220 food grade oil
- Anti-microbial clear coat
- 316 stainless steel epoxy coating
- Stainless steel shaft, hollow bore or double bushing output
- USDA Accepted Equipment

"B" Option for Corrosion Resistant Duty Applications

- Totally enclosed unit — no breathers, maintenance free, lubricated for life
- Mobil 600XP220 mineral oil
- 316 stainless steel epoxy coating
- Stainless steel shaft, hollow bore or double bushing output

Other F Series Design Options Available:

- Plated or stainless steel hardware
- IP69K certified (see page 6 for full details)





Overview

F Ordering Options At-a-Glance

F Series are available in a wide range of user-selected design options that tailor the speed reducer to your motor and exact application requirements. Use the appropriate order codes below to build a part number for the complete assembly.

Part Number Examples:

	1	2	3	4	5	6	7	8	9	0	I*
Standard duty	F	2	0	2	A	G	0043	MR140/	050		EL1
Food duty	F	2	0	2	A	G	0043	MR140/	050	F	EL1234

Design Option	Part Number Code	Description
1 Series	F	Offset helical (output is offset from input; gears are all helical)
2 Size	2	5 sizes of speed reducers (1, 2, 3, 4, 6)
3 Generation	0	First generation
4 # of Stages	2 3	Two or three stages (determined by ratio)
5 Output	A	Hollow bore output
	V	Solid shaft output (only available with output flange housing)
	W	Single or double wobble-free bushing
6 Housing	F	Output flange mount
	G	Pilot Circle Diameter (PCD) tapped holes
	GN	Foot mounting (with tapped holes for side mounting)
7 Ratio	0043	Ratios range from 4.3:1 to 552:1 (refer to Selection Data tables) Note: if a slower speed is required, units can be combined to achieve the necessary ratio for low speed applications. Contact STÖBER Drives Inc.
8 Motor Adapter	MR140 thru MR250	Round motor adapter sizes (refer to Selection Data tables)
9 NEMA Frame Size (refer to Selection Data tables)	050	56C
	140	143/145TC
	180	182/184TC
	210	213/215TC
0 Food & Corrosion Resistant Option	F	Food duty service
	B	Corrosion resistant duty service
I Mounting Position* <i>Refer to page 161 illustrations</i>	EL1 EL2	Mounting positions for 3 year warranty
	EL3 EL4	
	EL5 EL6	
	EL1234	
	EL5 EL6	

F Series: OFFSET — Solid Shaft / Hollow Output

* Mounting position is added to "notes" section of order.

F Series: OFFSET — Solid Shaft/Hollow Output

F Series Orientation

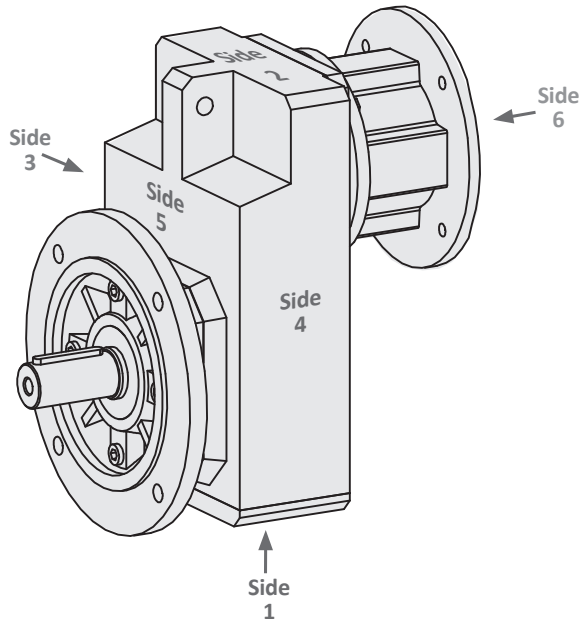

F Series Direction of Rotation

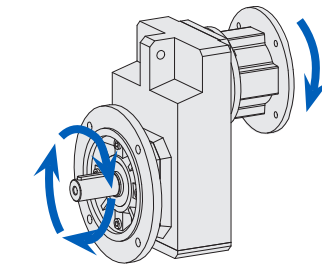

All 2 Stage Units

F102
F202
F302
F402
F602

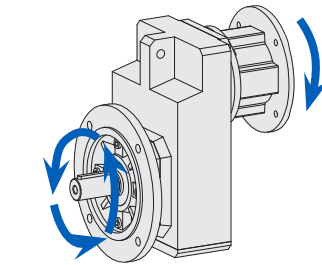

All 3 Stage Units

F203
F303
F403
F603

F Output and Housing Configurations

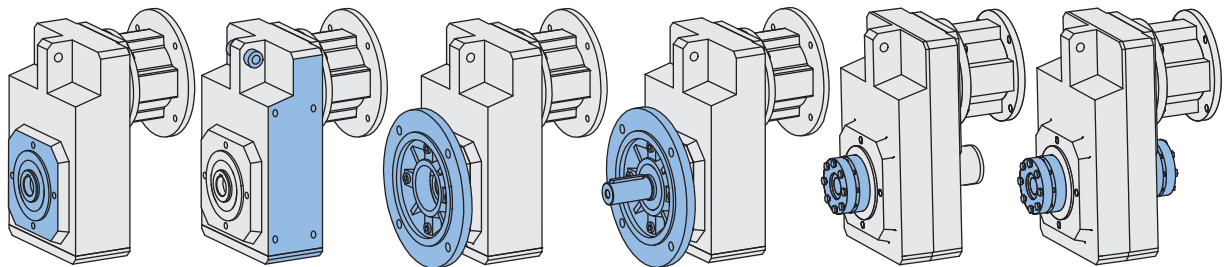

See Page	page <?>	page 170	page 172	page 173	page 174	page 176
Output	A Hollow Bore	A Hollow Bore	A Hollow Bore	V Solid Shaft	W Wobble Free Single Bushing*	W Wobble Free Double Bushing*
Housing	G Tapped Holes	GN Foot Mount (Sides 3 & 4)	F Flange Mount	F Flange Mount	G Tapped Holes	G Tapped Holes

* Single and double bushing outputs can be configured on side 5 (as shown); or on side 6 for two stage units only (same side as input). Please specify with order..

Availability*

Standard Duty	F1-F6	F1-F6	F1-F6	F1-F6	F1-F6	F1-F6 (2 stage units only)
Food & Corrosion Resistant Duty	F2-F4	F2-F4	F2-F4	—	F1-F6	F1-F6 (2 stage units only)

* See Output Options Chart page 161 for standard and optional solid shaft, hollow bore and wobble free bushing options.



Overview

F Series Output Options

BLUE: standard output diameters in stock

BLACK: optional diameters in stock

Other options are available upon request. Please contact STÖBER to learn about other options and their deliveries.

			F1	F2	F3	F4	F6
"V" Solid Shaft	Carbon Steel	Inches	1	1-1/4	1-3/8	1-5/8	2-1/8
		Metric	—	—	—	—	—
	Stainless Steel	Inches	—	—	—	—	—
		Metric	—	—	—	—	—
"A" Hollow Bore	Carbon Steel	Inches	3/4	1	1-1/4	1-7/16 1-1/2	2
		Metric	20	25	30	40	50
	Stainless Steel	Inches	—	—	1-1/4	1-1/2	—
		Metric	—	—	—	—	—
"W" Wobble Free Bushing	Stainless Steel Single & Double Bushings	Inches	3/4	1 1-3/16	1 1-3/16 1-1/4 1-7/16 1-1/2	1-7/16 1-1/2	1-7/16 1-1/2 1-15/16 2
	(Double Bushings only available with two stage units)	Metric	20	—	—	40*	—

* Double bushing only

F Series: OFFSET — Solid Shaft / Hollow Output

F Mounting Position Options

When ordering any F unit, the mounting position must be specified. Use one of the mounting position order codes illustrated below that corresponds to the intended application.

Standard Duty

All STÖBER standard duty units are filled with the correct amount of lubrication before shipping. In order to provide the proper lubrication quantity, the mounting position must be specified at the time the unit is ordered.

Food & Corrosion Resistant Duty

Food and Corrosion Resistant Duty units are equipped with specialized seals, higher oil level, and additional features compared to standard units. These added features enable all horizontal output positions (EL1, 2, 3 and 4) to be used interchangeably, subject to size and ratio. Contact STÖBER for details.

DO NOT mount any reducer in a position other than the mounting position specified on the order!

The only exception are the horizontal "F" & "B" duty reducers illustrated below.

These mounting positions for "F" Food or "B" Corrosion Resistant Duty are all interchangeable.

Side 1
EL1

Side 2
EL2

Side 3
EL3

Side 4
EL4

Side 5
EL5

Side 6
EL6

Standard Duty: EL1 EL2 EL3 EL4

Food & Corrosion Resistant: EL1234

F Series: OFFSET — Solid Shaft/Hollow Output

Permissible Motor Tilting Torque

The permissible tilting torque of the motor attached to the gear unit is a result of the static and dynamic load “F” from the motor weight, mass acceleration, and vibration multiplied by the distance from the center of gravity “ l_s ” of the motor.

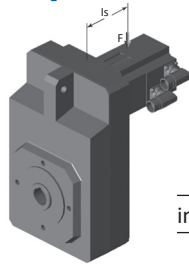

$$M_{1k} = F \times l_s \leq M_{1K}$$

M_{1K}	MR140	MR160	MR200	MR250
in.lbs	221	531	1106	2212



Selection Data

F Sizing/Selection:

1. Find the **RPM Output (Approximate)** nearest the application requirement. (If the exact Output RPM is required, divide the Input RPM [1750] by the value listed in the Nominal Ratio column.)
- 2a. In the **Input HP** column, locate the rating that is greater than or equal to the required HP, or;
- 2b. If selection is based on Torque instead of HP, find an **Output Torque** that is equal to or greater than required.
3. Confirm that the **Overhung Load** is acceptable for the application.
4. Choose the appropriate **Base Module**, **Motor Adapter** and **NEMA C-Frame** part number order codes (see page 159 for complete ordering information). An optional input shaft, in place of the NEMA C-face motor adapter, is also available.

1750 RPM Input		Nominal Ratio	Overhung Load Output Shaft ¹⁾ (lbs)	Part Number Codes (in blue)		
Input HP	Output Torque (lb-in)			Base Module	Motor Adapter/ NEMA Motor	Compatible NEMA C-Frame ²⁾ with Designated Motor Adapter
405 RPM Output (Approximate)						
3.83*	577	4.308	275	F102_0043	MR160/050	56C
					MR160/140	143/145TC
385 RPM Output (Approximate)						
21.97*	3,492	4.546	833	F602_0045	MR200/180	182/184TC
33.79*	5,371	4.546	833	F602_0045	MR250/210	213/215TC
315 RPM Output (Approximate)						
6.44*	1,250	5.552	385	F202_0056	MR160/050	56C
					MR160/140	143/145TC
					MR200/180	182/184TC
305 RPM Output (Approximate)						
8.73*	1,746	5.720	540	F302_0057	MR160/050	56C
					MR160/140	143/145TC
9.22	1,873	5.813	669	F402_0058	MR160/050	56C
					MR160/140	143/145TC
10.50*	2,101	5.720	540	F302_0057	MR200/180	182/184TC
					MR200/180	182/184TC
17.16*	3,488	5.813	669	F402_0058	MR250/210	213/215TC
					MR250/210	213/215TC

F Series: OFFSET — Solid Shaft / Hollow Output

* **Thermal HP Limit**

Base Module Size	F1	F2	F3	F4	F6
HP Limit	2.95	5.36	7.38	12.34	14.75

1) Overhung Load is measured at the center of the shaft extension. Hollow bore output units are not intended to support overhung loads. If a load rating is required, use 50% of the published overhung load.

2) Motor HP for TEFC NEMA C-Frame @ 1750 RPM	Order Code	050	140	180	210
C-Frame		56C	143/145TC	182/184TC	213/215TC
HP		1/4 to 1-1/2	1, 1-1/2, 2	3, 5	7-1/2, 10

F Series: OFFSET — Solid Shaft/Hollow Output

1750 RPM Input		Nominal Ratio	Overhung Load Output Shaft ¹⁾ (lbs)	Part Number Codes (in blue)		
Input HP	Output Torque (lb-in)			Base Module	Motor Adapter/ NEMA Motor	Compatible NEMA C-Frame ²⁾ with Designated Motor Adapter
244 RPM Output (Approximate)						
2.73	683	7.156	326	F102_0072	MR160/050	56C
					MR160/140	143/145TC
17.04*	4,264	7.159	969	F602_0072	MR200/180	182/184TC
24.96*	6,248	7.159	969	F602_0072	MR250/210	213/215TC
195 RPM Output (Approximate)						
4.66	1,468	9.006	452	F202_0090	MR160/050	56C
					MR160/140	143/145TC
					MR200/180	182/184TC
6.87	2,159	8.986	627	F302_0090	MR160/050	56C
					MR160/140	143/145TC
7.70	2,418	8.980	773	F402_0090	MR160/050	56C
					MR160/140	143/145TC
7.77*	2,442	8.986	627	F302_0090	MR200/180	182/184TC
12.84*	4,032	8.980	773	F402_0090	MR200/180	182/184TC
					MR250/210	213/215TC
160 RPM Output (Approximate)						
2.06	787	10.920	375	F102_0110	MR160/050	56C
					MR160/140	143/145TC
4.13	1,560	10.803	480	F202_0110	MR160/050	56C
					MR160/140	143/145TC
					MR200/180	182/184TC
5.98	2,253	10.785	667	F302_0110	MR160/050	56C
					MR160/140	143/145TC
6.66	2,520	10.825	823	F402_0110	MR160/050	56C
					MR160/140	143/145TC
6.88	2,595	10.785	667	F302_0110	MR200/180	182/184TC
7.57	2,861	10.818	1,112	F602_0110	MR160/050	56C
					MR160/140	143/145TC
11.34	4,291	10.825	823	F402_0110	MR200/180	182/184TC
					MR250/210	213/215TC
13.28	5,024	10.818	1,112	F602_0110	MR200/180	182/184TC
18.96*	7,170	10.818	1,112	F602_0110	MR250/210	213/215TC

1) Overhung Load is measured at the center of the shaft extension.

2) Motor HP for TEFC NEMA C-Frame @ 1750 RPM

Order Code	050	140	180	210
C-Frame	56C	143/145TC	182/184TC	213/215TC
HP	1/4 to 1-1/2	1, 1-1/2, 2	3, 5	7-1/2, 10

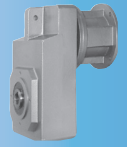

Selection Data

1750 RPM Input		Nominal Ratio	Overhung Load Output Shaft ¹⁾ (lbs)	Part Number Codes (in blue)		
Input HP	Output Torque (lb-in)			Base Module	Motor Adapter/ NEMA Motor	Compatible NEMA C-Frame ²⁾ with Designated Motor Adapter
130 RPM Output (Approximate)						
3.54	1,686	13.625	519	F202_0135	MR160/050	56C
					MR160/140	143/145TC
					MR200/180	182/184TC
5.12	2,395	13.384	716	F302_0135	MR160/050	56C
					MR160/140	143/145TC
5.86	2,781	13.569	887	F402_0135	MR160/050	56C
					MR160/140	143/145TC
5.96	2,789	13.384	716	F302_0135	MR200/180	182/184TC
					MR200/180	182/184TC
9.75	4,627	13.569	887	F402_0135	MR250/210	213/215TC
					MR250/210	213/215TC
95 RPM Output (Approximate)						
1.45	937	18.457	446	F102_0185	MR160/050	56C
					MR160/140	143/145TC
13.25	8,578	18.522	1,330	F602_0185	MR200/180	182/184TC
					MR250/210	213/215TC
75 RPM Output (Approximate)						
2.47	2,020	23.434	622	F202_0230	MR160/050	56C
					MR160/140	143/145TC
4.09	3,365	23.520	864	F302_0240	MR160/050	56C
					MR160/140	143/145TC
					MR200/180	182/184TC
6.82	5,534	23.214	1,061	F402_0230	MR160/050	56C
					MR160/140	143/145TC
					MR200/180	182/184TC

F Series: OFFSET — Solid Shaft / Hollow Output

* Thermal HP Limit

Base Module Size	F1	F2	F3	F4	F6
HP Limit	2.95	5.36	7.38	12.34	14.75

F Series: OFFSET — Solid Shaft/Hollow Output

1750 RPM Input		Nominal Ratio	Overhung Load Output Shaft ¹⁾ (lbs)	Part Number Codes (in blue)		
Input HP	Output Torque (lb-in)			Base Module	Motor Adapter/ NEMA Motor	Compatible NEMA C-Frame ²⁾ with Designated Motor Adapter
60 RPM Output (Approximate)						
1.08	1,063	28.167	514	F102_0280	MR160/050	56C
					MR160/140	143/145TC
2.16	2,126	28.112	660	F202_0280	MR160/050	56C
					MR160/140	143/145TC
3.59	3,543	28.230	919	F302_0280	MR160/050	56C
					MR160/140	143/145TC
					MR200/180	182/184TC
6.02	5,890	27.986	1,130	F402_0280	MR160/050	56C
					MR160/140	143/145TC
					MR200/180	182/184TC
7.57	7,401	27.986	1,527	F602_0280	MR160/050	56C
					MR160/140	143/145TC
9.96	9,744	27.986	1,527	F602_0280	MR200/180	182/184TC
					MR250/210	213/215TC
50 RPM Output (Approximate)						
1.72	2,126	35.455	714	F202_0350	MR160/050	56C
					MR160/140	143/145TC
2.89	3,543	35.034	987	F302_0350	MR160/050	56C
					MR160/140	143/145TC
5.06	6,201	35.079	1,218	F402_0350	MR160/050	56C
					MR160/140	143/145TC
					MR200/180	182/184TC
35 RPM Output (Approximate)						
0.65	1,063	46.429	607	F102_0460	MR160/050	56C
2.15	3,543	47.185	1,090	F302_0470	MR160/050	56C
					MR160/140	143/145TC
5.11	8,344	46.719	1,811	F602_0470	MR160/050	56C
					MR160/140	143/145TC
5.97	9,744	46.719	1,811	F602_0470	MR200/180	182/184TC

1) Overhung Load is measured at the center of the shaft extension.

2) Motor HP for TEFC NEMA C-Frame @ 1750 RPM

Order Code	050	140	180	210
C-Frame	56C	143/145TC	182/184TC	213/215TC
HP	1/4 to 1-1/2	1, 1-1/2, 2	3, 5	7-1/2, 10



Selection Data

1750 RPM Input		Nominal Ratio	Overhung Load Output Shaft ¹⁾ (lbs)	Part Number Codes (in blue)		
Input HP	Output Torque (lb-in)			Base Module	Motor Adapter/ NEMA Motor	Compatible NEMA C-Frame ²⁾ with Designated Motor Adapter
30 RPM Output (Approximate)						
0.54	1,063	55.972	646	F102_0560	MR160/050	56C
1.07	2,126	56.727	835	F202_0570	MR160/050	56C
					MR160/140	143/145TC
1.79	3,543	56.486	1,158	F302_0560	MR160/050	56C
					MR160/140	143/145TC
3.17	6,201	55.972	1,423	F402_0560	MR160/050	56C
					MR160/140	143/145TC
					MR200/180	182/184TC
4.50	8,775	55.714	1,920	F602_0560	MR160/050	56C
					MR160/140	143/145TC
5.00	9,744	55.714	1,920	F602_0560	MR200/180	182/184TC
25 RPM Output (Approximate)						
0.43	1,063	70.056	696	F102_0700	MR160/050	56C
0.87	2,126	70.130	896	F202_0700	MR160/050	56C
1.44	3,543	70.359	1,245	F302_0700	MR160/050	56C
					MR160/140	143/145TC
2.53	6,201	70.056	1,534	F402_0700	MR160/050	56C
					MR160/140	143/145TC
19 RPM Output (Approximate)						
0.33	1,063	93.631	767	F102_0940	MR140/050	56C
0.65	2,126	93.818	987	F202_0940	MR160/050	56C
					MR160/050	56C
1.08	3,543	93.644	1,370	F302_0940	MR160/140	143/145TC
					MR160/050	56C
1.90	6,201	93.333	1,688	F402_0930	MR160/140	143/145TC
					MR160/050	56C
2.84	9,258	93.333	2,281	F602_0930	MR160/050	56C
					MR160/140	143/145TC
15 RPM Output (Approximate)						
0.27	1,063	111.944	814	F102_1120	MR140/050	56C
0.90	3,543	112.848	1,458	F302_1130	MR160/050	56C
					MR160/050	56C
1.58	6,201	112.273	1,795	F402_1120	MR160/140	143/145TC
					MR160/050	56C
2.43	9,546	112.202	2,425	F602_1120	MR160/050	56C
					MR160/140	143/145TC

F Series: OFFSET — Solid Shaft / Hollow Output

* Thermal HP Limit

Base Module Size	F1	F2	F3	F4	F6
HP Limit	2.95	5.36	7.38	12.34	14.75

F Series: OFFSET — Solid Shaft/Hollow Output

1750 RPM Input		Nominal Ratio	Overhung Load Output Shaft ¹⁾ (lbs)	Part Number Codes (in blue)		
Input HP	Output Torque (lb-in)			Base Module	Motor Adapter/ NEMA Motor	Compatible NEMA C-Frame ²⁾ with Designated Motor Adapter
10 RPM Output (Approximate)						
0.56	3,543	182.449	1,688	F303_1820	MR160/050	56C
1.57	9,744	180.646	2,813	F603_1810	MR160/050	56C
					MR160/140	143/145TC
8 RPM Output (Approximate)						
0.28	2,126	222.182	1,215	F203_2220	MR140/050	56C
0.47	3,543	218.413	1,688	F303_2180	MR160/050	56C
0.83	6,201	216.426	2,081	F403_2160	MR160/050	56C
1.31	9,744	215.429	2,813	F603_2150	MR160/050	56C
					MR160/140	143/145TC
6 RPM Output (Approximate)						
0.22	2,126	274.675	1,215	F203_2750	MR140/050	56C
0.36	3,540	275.573	1686	F303_2760	MR140/050	56C
0.38	3,543	272.055	1,688	F303_2720	MR160/050	56C
0.63	6,196	274.384	2079	F403_2740	MR140/050	56C
0.66	6,201	270.881	2,081	F403_2710	MR160/050	56C
5 RPM Output (Approximate)						
0.17	2,126	367.455	1,215	F203_3670	MR140/050	56C
0.27	3,540	366.774	1686	F303_3670	MR140/050	56C
0.28	3,543	362.092	1,688	F303_3620	MR160/050	56C
0.47	6,196	365.556	2079	F403_3660	MR140/050	56C
0.50	6,201	360.889	2,081	F403_3610	MR160/050	56C
0.78	9,744	360.889	2,813	F603_3610	MR160/050	56C
4 RPM Output (Approximate)						
0.23	3,543	441.990	1,688	F303_4420	MR140/050	56C
0.39	6,196	439.735	2079	F403_4400	MR140/050	56C
0.41	6,201	434.121	2,081	F403_4340	MR160/050	56C
0.65	9,744	433.849	2,813	F603_4340	MR160/050	56C

NOTE: For slower speeds than those shown, units can be combined. Contact STÖBER Drives Inc.

1) Overhung Load is measured at the center of the shaft extension.

2) Motor HP for TEFC NEMA C-Frame @ 1750 RPM

Order Code	050	140	180	210
C-Frame	56C	143/145TC	182/184TC	213/215TC
HP	1/4 to 1-1/2	1, 1-1/2, 2	3, 5	7-1/2, 10



Selection Data

"A" Hollow Output with "G" Pilot Circle Diameter (PCD) Tapped Holes — All Sizes

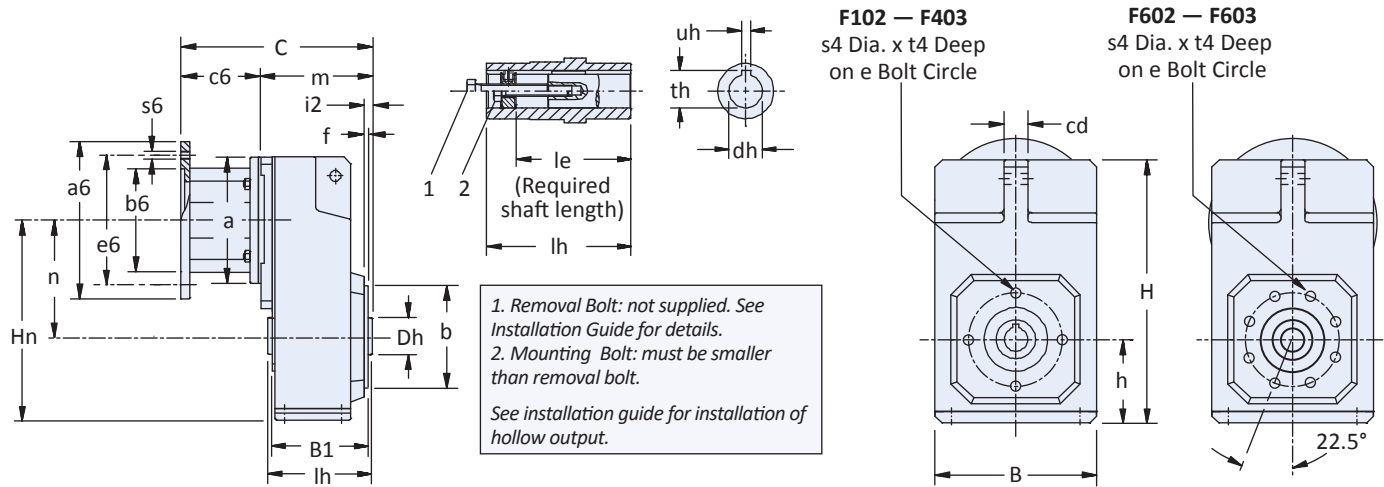

Table 1 F Series Unit Dimensions (Inches) — "G" Pilot Circle Diameter (PCD) Tapped Holes

Base Module	B	b	B1	cd	Dh	e	f	H	h	Hn	i2	le	lh	n	s4	t4	Removal Bolt 1
F1	5.71	2.756	3.43	0.79	1.38	3.35	0.10	9.37	2.91	6.93	0.26	2.87	3.74	4.02	M8x1.25	0.51	3/8-16
F2	7.09	3.740	4.13	0.87	1.77	4.53	0.12	11.77	3.66	8.82	0.31	3.62	4.53	5.16	M8x1.25	0.51	1/2-13
F3	8.11	4.331	4.72	1.18	1.97	5.12	0.14	13.23	4.17	10.06	0.33	4.06	5.12	5.89	M10x1.5	0.63	1/2-13
F4	9.06	4.331	5.31	1.18	2.17	5.12	0.14	14.57	4.57	11.22	0.33	4.49	5.71	6.65 ¹⁾	M10x1.5	0.63	3/4-10
F6	10.43	5.118	6.54	1.38	2.76	6.50	0.14	17.64	5.39	13.11	0.41	5.63	7.09	7.72	M10x1.5	0.63	3/4-10

¹⁾ CD is 5.19 for F403 with MR160/050 or MR160/140 input

Table 2 F Series Unit Dimensions (Inches) — Standard "A" Hollow Bore Output
(see page 161 for all other optional outputs)

Base Module	Stainless Steel			Carbon Steel		
	dh	th	uh	dh	th	uh
F1	—	—	—	3/4	0.84	3/16
F2	1	1.12	1/4	1	1.12	1/4
F3	1-1/4	1.37	1/4	1-1/4	1.37	1/4
F4	1-1/2	1.67	3/8	1-1/2	1.67	3/8
F6	—	—	—	2	2.23	1/2

Table 3 F Series Unit Dimensions (inches) — "MR" Motor Adapter

Motor Adapter	NEMA C-Flange	a	a6	b6	c6	e6	s6	Wt. lbs
MR140/050	56C	5.51	6.50	4.500	3.31	5.87	0.41	9
MR160/050	56C	6.30	6.50	4.500	3.86	5.87	0.41	16
MR160/140	143/145TC	7.87	9.00	8.500	4.80	7.25	0.55	23
MR200/180	182/184TC	9.84	9.00	8.500	5.31	7.25	0.55	36
MR250/180	182/184TC	—	—	—	—	—	—	—
MR250/210	213/215TC	—	—	—	—	—	—	—

Table 4 Motor Adapter Dimensions (Inches)

Base Module	MR140/050		MR160/050 MR160/140		MR200/180		MR250/180 MR250/210		Wt. lbs*
	C	m	C	m	C	m	C	m	
F102	7.40	4.09	8.11	4.25	—	—	—	—	38
F202	8.15	4.84	8.86	5.00	9.88	5.08	—	—	51
F203	9.61	6.30	—	—	—	—	—	—	64
F302	8.74	5.43	9.45	5.59	10.47	5.67	—	—	67
F303	10.20	6.89	11.14	7.28	—	—	—	—	73
F402	—	—	10.04	6.18	11.06	6.26	11.68	6.38	84
F403	10.79	7.48	11.73	7.87	—	—	—	—	91
F602	—	—	11.34	7.48	12.36	7.56	12.99	7.68	165
F603	—	—	13.03	9.17	—	—	—	—	177

* Weight is base unit only. MR weight must be added separately.

F Series: OFFSET — Solid Shaft / Hollow Output

F Series: OFFSET — Solid Shaft/Hollow Output

"A" Hollow Output with "GN" Foot Mounting — All Sizes

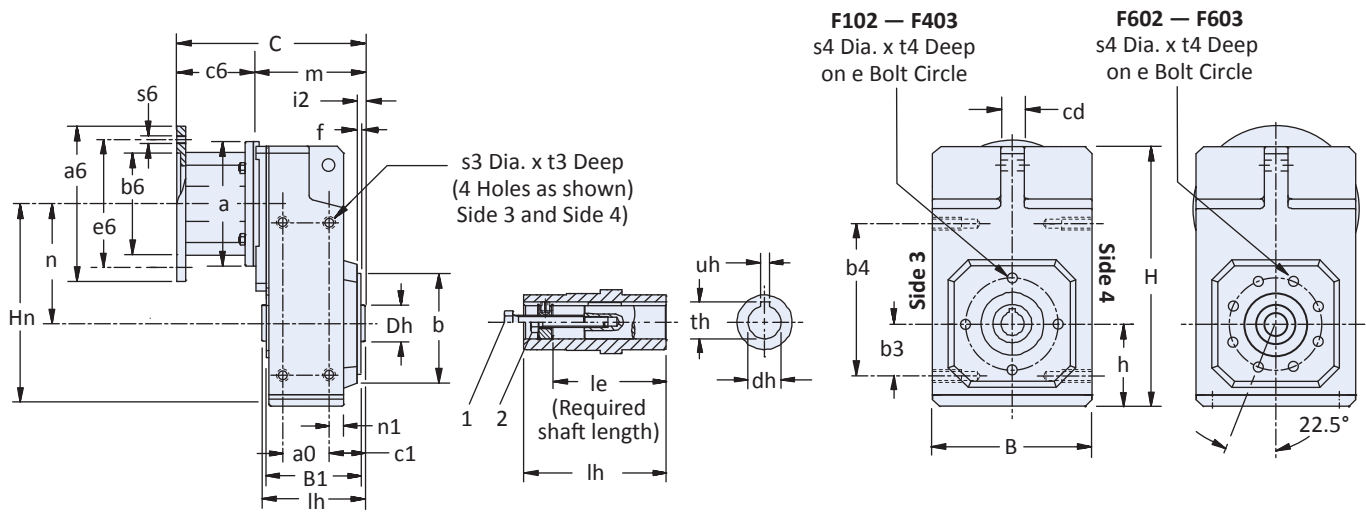

1. Removal Bolt: not supplied. See Installation Guide for details.
 2. Mounting Bolt: must be smaller than removal bolt.
 See installation guide for installation of hollow output.

Table 1 F Series Unit Dimensions (Inches) — "GN" Foot Mount Housing

Base Module	a0	B	b	B1	b3	b4	C1	cd	Dh	e	f	H
F1	1.97	5.71	2.756	3.43	1.57	5.51	1.14	0.79	1.38	3.35	0.10	9.37
F2	2.52	7.09	3.740	4.13	2.17	6.89	1.32	0.87	1.77	4.53	0.12	11.77
F3	2.83	8.11	4.331	4.72	2.36	7.87	1.48	1.18	1.97	5.12	0.14	13.23
F4	3.43	9.06	4.331	5.31	2.76	8.66	1.48	1.18	2.17	5.12	0.14	14.57
F6	4.25	10.43	5.118	6.54	3.35	10.63	1.83	1.38	2.76	6.50	0.14	17.64

¹⁾ CD is 5.19 for F403 with MR160/050 or MR160/140 input

Table 2 F Series Unit Dimensions (Inches) — "GN" Foot Mount Housing

Base Module	h	Hn	i2	le	lh	n	n1	s3	s4	t3	t4	Removal Bolt 1
F1	2.91	6.93	0.26	2.87	3.74	4.02	0.39	M6	M8x1.25	0.43	0.51	3/8 – 16
F2	3.66	8.82	0.31	3.62	4.53	5.16	0.41	M8	M8x1.25	0.51	0.51	1/2 – 13
F3	4.17	10.06	0.33	4.06	5.12	5.89	0.49	M10	M10x1.5	0.63	0.63	1/2 – 13
F4	4.57	11.22	0.33	4.49	5.71	6.65 ¹⁾	0.49	M10	M10x1.5	0.63	0.63	3/4 – 10
F6	5.39	13.11	0.41	5.63	7.09	7.72	0.61	M12	M10x1.5	0.75	0.63	3/4 – 10



Dimensional Data

Table 3 F Series Unit Dimensions (Inches) — Standard “A” Hollow Bore Output
(see page 161 for all other optional outputs)

Base Module	Stainless Steel			Carbon Steel		
	dh	th	uh	dh	th	uh
F1	—	—	—	3/4	0.84	3/16
F2	1	1.12	1/4	1	1.12	1/4
F3	1-1/4	1.37	1/4	1-1/4	1.37	1/4
F4	1-1/2	1.67	3/8	1-1/2	1.67	3/8
F6	—	—	—	2	2.23	1/2

Table 4 F Series Unit Dimensions (inches) — “MR” Motor Adapter

Motor Adapter	NEMA C-Flange	a	a6	b6	c6	e6	s6	Wt. lbs
MR140/050	56C	5.51	6.50	4.500	3.31	5.87	0.41	9
MR160/050	56C	6.30	6.50	4.500	3.86	5.87	0.41	16
MR160/140	143/145TC							
MR200/180	182/184TC	7.87	9.00	8.500	4.80	7.25	0.55	23
MR250/180	182/184TC	9.84	9.00	8.500	5.31	7.25	0.55	36
MR250/210	213/215TC							

Table 5 Motor Adapter Dimensions (Inches)

Base Module	MR140/050		MR160/050 MR160/140		MR200/180		MR250/180 MR250/210		Wt. lbs*
	C	m	C	m	C	m	C	m	
F102	7.40	4.09	8.11	4.25	—	—	—	—	38
F202	8.15	4.84	8.86	5.00	9.88	5.08	—	—	51
F203	9.61	6.30	—	—	—	—	—	—	64
F302	8.74	5.43	9.45	5.59	10.47	5.67	—	—	67
F303	10.20	6.89	11.14	7.28	—	—	—	—	73
F402	—	—	10.04	6.18	11.06	6.26	11.68	6.38	84
F403	10.79	7.48	11.73	7.87	—	—	—	—	91
F602	—	—	11.34	7.48	12.36	7.56	12.99	7.68	165
F603	—	—	13.03	9.17	—	—	—	—	177

* Weight is base unit only. MR weight must be added separately.

Rubber Buffer Option for Torque Arm Bracket Mounting

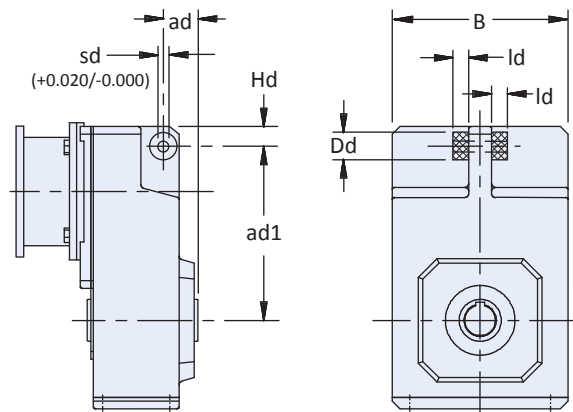

Table 1 F Series Unit Dimensions (Inches) – Rubber Buffer Option

Base Module	Part Number	ad	ad1	B	Dd	Hd	Id	sd
F1	126850	1.38	5.91	5.72	1.18	0.55	0.59	0.43
F2	126850	1.57	7.12	7.10	1.18	0.98	0.59	0.43
F3	126851	1.77	8.07	8.12	1.57	0.96	0.79	0.55
F4	126851	1.77	8.98	9.06	1.57	1.02	0.79	0.55
F6	126852	2.77	10.63	10.44	2.36	1.02	1.18	0.57

Order two (2) rubber buffers for each unit.
Torque arms are not supplied by STÖBER.

F Series: OFFSET — Solid Shaft / Hollow Output

F Series: OFFSET — Solid Shaft/Hollow Output

"A" Hollow Output with "F" Output Flange — All Sizes

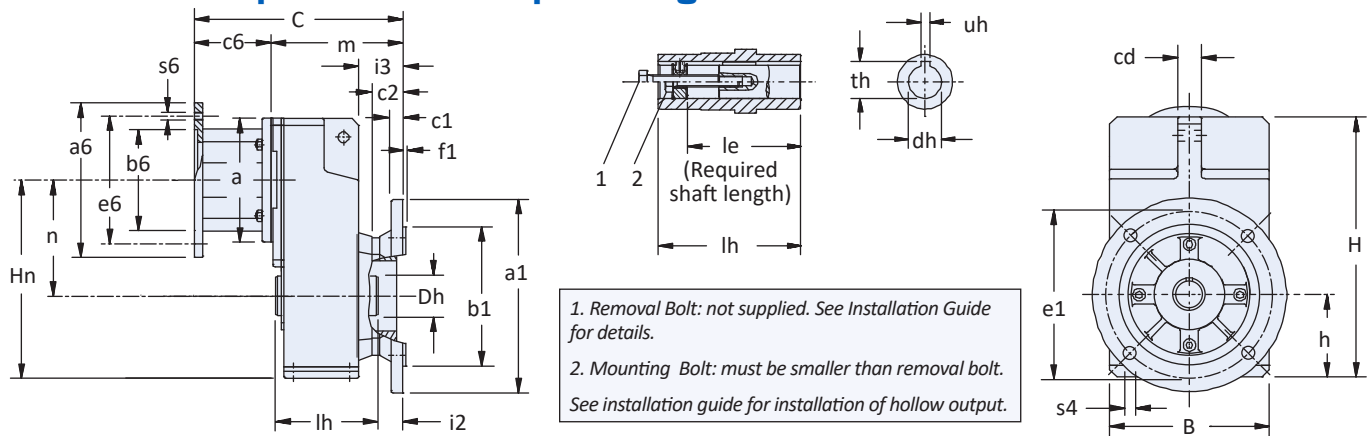

Table 1 F Series Unit Dimensions (Inches) — "F" Round Flange Housing

Base Module	a1	B	b1	cd	c1	c2	Dh	e1	f1	H
F1	6.30	5.71	4.331	0.79	0.39	0.26	1.38	5.12	0.14	9.37
F2	7.87	7.09	5.118	0.87	0.55	0.31	1.77	6.50	0.14	11.77
F3	9.84	8.11	7.087	1.18	0.59	0.33	1.97	8.46	0.16	13.23
F4	9.84	9.06	7.087	1.18	0.59	0.33	2.17	8.46	0.16	14.57
F6	11.81	10.43	9.055	1.38	0.67	0.41	2.76	10.43	0.16	17.64

¹⁾ CD is 5.19 for F403 with MR160/050 or MR160/140 input

Table 2 F Series Unit Dimensions (Inches) — "F" Round Flange Housing

Base Module	h	Hn	i2	i3	le	lh	n	s4	Removal Bolt 1
F1	2.91	6.93	1.00	1.75	2.87	3.74	4.02	M8x1.25	3/8 – 16
F2	3.66	8.82	1.18	2.09	3.62	4.53	5.16	M8x1.25	1/2 – 13
F3	4.17	10.06	1.24	2.22	4.06	5.12	5.89	M10x1.5	1/2 – 13
F4	4.57	11.22	1.24	2.22	4.49	5.71	6.65 ¹⁾	M10x1.5	3/4 – 10
F6	5.39	13.11	1.16	2.38	5.63	7.09	7.72	M10x1.5	3/4 – 10

Table 3 F Series Unit Dimensions (Inches) — Standard "A" Hollow Bore Output

(see page 161 for all other optional outputs)

Base Module	Stainless Steel			Carbon Steel		
	dh	th	uh	dh	th	uh
F1	—	—	—	3/4	0.84	3/16
F2	1	1.12	1/4	1	1.12	1/4
F3	1-1/4	1.37	1/4	1-1/4	1.37	1/4
F4	1-1/2	1.67	3/8	1-1/2	1.67	3/8
F6	—	—	—	2	2.23	1/2

Table 4 F Series Unit Dimensions (inches) — "MR" Motor Adapter

Motor Adapter	NEMA C-Flange	a	a6	b6	c6	e6	s6	Wt. lbs
MR140/050	56C	5.51	6.50	4.500	3.31	5.87	0.41	9
MR160/050	56C	6.30	6.50	4.500	3.86	5.87	0.41	16
MR160/140	143/145TC	6.30	9.00	8.500	4.80	7.25	0.55	23
MR200/180	182/184TC	7.87	9.00	8.500	4.80	7.25	0.55	23
MR250/180	182/184TC	9.84	9.00	8.500	5.31	7.25	0.55	36
MR250/210	213/215TC	9.84	9.00	8.500	5.31	7.25	0.55	36

Table 5 Motor Adapter Dimensions (Inches)

Base Module	MR140/050		MR160/050		MR160/140		MR200/180		MR250/180		MR250/210		Wt. lbs*
	C	m	C	m	C	m	C	m	C	m	C	m	
F102	8.43	5.12	9.13	5.27	—	—	—	—	—	—	—	—	38
F202	9.34	6.03	10.04	6.18	11.06	6.26	—	—	—	—	—	—	51
F203	10.79	7.48	—	—	—	—	—	—	—	—	—	—	64
F302	10.00	6.69	10.71	6.85	11.73	6.93	—	—	—	—	—	—	67
F303	11.46	8.15	12.38	8.52	—	—	—	—	—	—	—	—	73
F402	—	—	11.30	7.44	12.32	7.52	12.95	7.64	—	—	—	—	84
F403	12.05	8.74	12.99	9.13	—	—	—	—	—	—	—	—	91
F602	—	—	12.52	8.66	13.54	8.74	14.17	8.86	—	—	—	—	165
F603	—	—	14.21	10.35	—	—	—	—	—	—	—	—	177

* Weight is base unit only. MR weight must be added separately.



Dimensional Data

"V" Shaft Output with "F" Output Flange — All Sizes

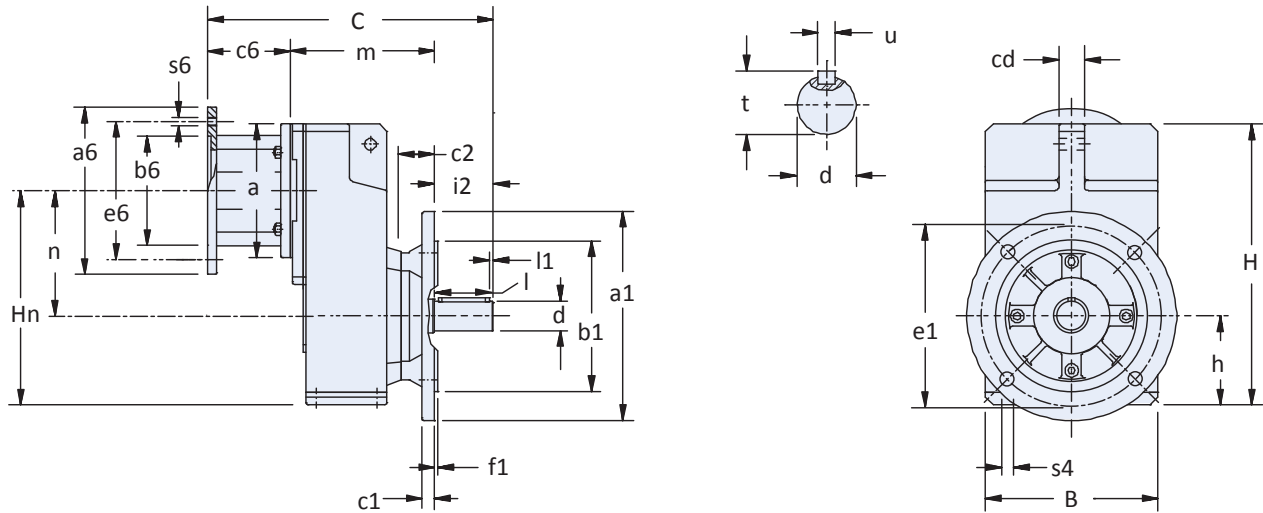

Table 1 F Series Unit Dimensions (Inches) — "F" Round Flange Housing

Base Module	a1	B	b1	cd	c1	c2	e1	f1	H	h	Hn	i2	l	l1	n	s4
F1	6.30	5.71	4.331	0.79	0.39	0.26	5.12	0.14	9.37	2.91	6.93	1.97	1.97	0.16	4.02	0.35
F2	7.87	7.09	5.118	0.87	0.55	0.31	6.50	0.14	11.77	3.66	8.82	2.36	2.36	0.16	5.16	0.43
F3	9.84	8.11	7.087	1.18	0.59	0.33	8.46	0.16	13.23	4.17	10.06	2.75	2.76	0.16	5.89	0.55
F4	9.84	9.06	7.087	1.18	0.59	0.33	8.46	0.16	14.57	4.57	11.22	3.15	3.15	0.16	6.65 ¹⁾	0.55
F6	11.81	10.43	9.055	1.38	0.67	0.41	10.43	0.16	17.64	5.39	13.11	3.94	3.94	0.20	7.72	0.55

1) C.D. is 5.19 for F403 with MR160/050 or MR160/140 input.

Table 2 Series Unit Dimensions (Inches) — Standard "V" Solid Shaft Output

Base Module	Carbon Steel		
	d	t	u
F1	1	1.11	1/4x1/4x1-9/16
F2	1-1/4	1.36	1/4x1/4x1-15/16
F3	1-3/8	1.51	5/16x5/16x2-5/16
F4	1-5/8	1.79	3/8x3/8x2-7/8
F6	2-1/8	2.35	1/2x1/2x3-5/32

Table 3 F Series Unit Dimensions (inches) — "MR" Motor Adapter

Motor Adapter	NEMA C-Flange	a	a6	b6	c6	e6	s6	Wt. lbs
MR140/050	56C	5.51	6.50	4.500	3.31	5.87	0.41	9
MR160/050	56C	6.30	6.50	4.500	3.86	5.87	0.41	16
MR160/140	143/145TC	6.30	6.50	4.500	3.86	5.87	0.41	16
MR200/180	182/184TC	7.87	9.00	8.500	4.80	7.25	0.55	23
MR250/180	182/184TC	9.84	9.00	8.500	5.31	7.25	0.55	36
MR250/210	213/215TC	9.84	9.00	8.500	5.31	7.25	0.55	36

Table 4 Motor Adapter Dimensions (Inches)

Base Module	MR140/050			MR160/050 MR160/140			MR200/180			MR250/180 MR250/210			Wt. lbs*
	C	l	m	C	l	m	C	l	m	C	l	m	
F102	10.40	1.97	5.12	11.10	1.97	5.27	—	—	—	—	—	—	38
F202	11.70	2.36	6.03	12.40	2.36	6.18	13.42	2.36	6.26	—	—	—	51
F203	13.15	2.36	7.48	—	—	—	—	—	—	—	—	—	64
F302	12.76	2.76	6.69	13.47	2.76	6.85	14.49	2.76	6.93	—	—	—	67
F303	14.22	2.76	8.15	15.13	2.76	8.52	—	—	—	—	—	—	73
F402	—	—	—	14.45	3.15	7.44	15.47	3.15	7.52	16.10	3.15	7.64	84
F403	15.20	3.15	8.74	16.14	3.15	9.13	—	—	—	—	—	—	91
F602	—	—	—	16.46	3.94	8.66	17.48	3.94	8.74	18.11	3.94	8.86	165
F603	—	—	—	18.15	3.94	10.35	—	—	—	—	—	—	177

* Weight is base unit only. MR weight must be added separately.

F Series: OFFSET — Solid Shaft / Hollow Output

F Series: OFFSET — Solid Shaft/Hollow Output

“W” Single Bushing with “G” Pilot Circle Diameter (PCD) Tapped Holes — All Sizes

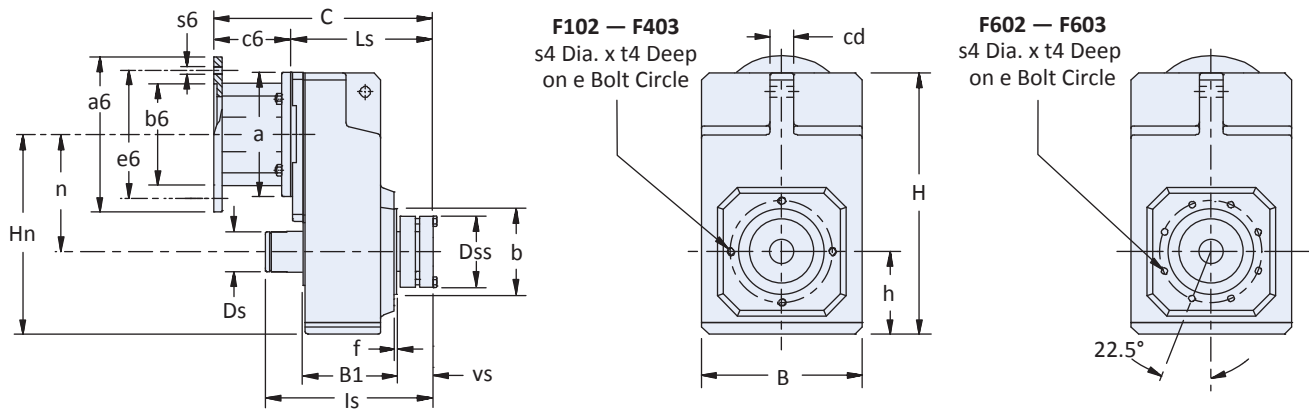

Table 1 F Series Unit Dimensions (Inches) — “W” Single Side Wobble Free Bushing

Base Module	B	b	B1	cd	Ds	Dss	e	f
F1	5.71	2.953	3.43	0.79	1.35	2.68	3.54	0.10
F2	7.09	3.740	4.13	0.87	1.74	3.07	4.53	0.12
F3	8.11	4.331	4.72	1.18	1.90	3.31	5.12	0.14
F4	9.06	4.331	5.31	1.18	2.14	3.82	5.12	0.14
F6	10.43	5.118	6.54	1.38	2.53	4.13	6.50	0.14

1) C.D. is 5.19 for F403 with MR160/050 or MR160/140 input.

Table 2 F Series Unit Dimensions (Inches) — “W” Single Side Wobble Free Bushing

Base Module	H	h	Hn	ls	n	s4	t4	vs
F1	9.37	2.91	6.93	6.40	4.02	M8x1.25	0.51	1.18
F2	11.77	3.66	8.82	7.26	5.16	M8x1.25	0.51	1.54
F3	13.23	4.17	10.06	7.95	5.89	M10x1.5	0.63	1.54
F4	14.57	4.57	11.22	8.93	6.65 ¹⁾	M10x1.5	0.63	1.78
F6	17.64	5.39	13.11	10.24	7.72	M10x1.5	0.63	1.77

Table 3 Bushing Capscrew Dimensions

Base Module	Bushings Capscrew Qty – Size x Length (mm)	Tightening Torque	
		in. lbs	Nm
F1	6 – M6 x 1 x 25	89	10
F2	8 – M6 x 1 x 30	89	10
F3	8 – M6 x 1 x 30	89	10
F4	8 – M8 x 1.25 x 30	221	25
F6	8 – M8 x 1.25 x 30	221	25

Table 4 Required Output Shaft Length*

Base Module	Length (in)
F1	6.57
F2	7.51
F3	8.20
F4	9.18
F6	10.48

* **Important:** A 1/32" x 45° chamfer minimum is recommended for the shaft end. The bushing will accept a shaft with a tolerance of +0.000/-0.005 in.

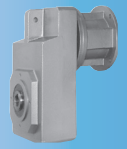

Dimensional Data

Table 5 F Series Unit Dimensions (inches) — “MR” Motor Adapter

Motor Adapter	NEMA C-Flange	a	a6	b6	c6	e6	s6	Wt. lbs
MR140/050	56C	5.51	6.50	4.500	3.31	5.87	0.41	9
MR160/050	56C	6.30	6.50	4.500	3.86	5.87	0.41	16
MR160/140	143/145TC							
MR200/180	182/184TC	7.87	9.00	8.500	4.80	7.25	0.55	23
MR250/180	182/184TC	9.84	9.00	8.500	5.31	7.25	0.55	36
MR250/210	213/215TC							

Table 6 Motor Adapter Dimensions (Inches)

Base Module	MR140/050		MR160/050 MR160/140		MR200/180		MR250/180 MR250/210		Wt. lbs*
	C	Ls	C	Ls	C	Ls	C	Ls	
F102	8.42	5.11	9.13	5.27	—	—	—	—	38
F202	9.50	6.19	10.21	6.35	11.23	6.43	—	—	51
F203	10.96	7.65	—	—	—	—	—	—	64
F302	10.09	6.78	10.80	6.94	11.82	7.02	—	—	67
F303	11.55	8.24	12.49	8.63	—	—	—	—	73
F402	—	—	11.63	7.77	12.65	7.85	13.28	7.97	84
F403	12.38	9.07	13.32	9.46	—	—	—	—	91
F602	—	—	12.84	8.98	13.86	9.06	14.49	9.18	165
F603	—	—	14.53	10.67	—	—	—	—	177

* Weight is base unit only. MR weight must be added separately.

Table 7 “WF” Single Side Bushings Stock Bore Sizes — Stainless Steel

NOTE: Single side bushing kits include 1 each of the pressure and locking ring, tapered cone, support ring, and all hardware to mount the kit into the MGS reducer. The WF1 bushing does not use a tapered cone. The bushing will accept a shaft with a tolerance of +0.000/-0.005.

Base Module	Imperial — Inches													Metric — mm		
	3/4	1	1-3/16	1-1/4	1-3/8	1-7/16	1-1/2	1-5/8	1-11/16	1-3/4	1-7/8	1-15/16	2	20	30	35
F1	WF1-075	—	—	—	—	—	—	—	—	—	—	—	—	WF1-20	—	—
F2	—	WF2-100	WF2-103	—	—	—	—	—	—	—	—	—	—	—	WF2-30	—
F3	—	WF3-100	WF3-103	WF3-104	WF3-106	WF3-107	WF3-108	—	—	—	—	—	—	—	WF3-30	WF3-35
F4	—	WF4-100	WF4-103	WF4-104	WF4-106	WF4-107	WF4-108	—	—	—	—	—	—	—	—	—
F6	—	—	—	—	—	WF5-107	WF5-108	WF5-110	WF5-111	WF5-112	WF5-114	WF5-115	WF5-200	—	—	—

F Series: OFFSET — Solid Shaft / Hollow Output

F Series: OFFSET — Solid Shaft/Hollow Output

“W” Double Bushing with “G” Pilot Circle Diameter (PCD) Tapped Holes — Two Stage Units Only

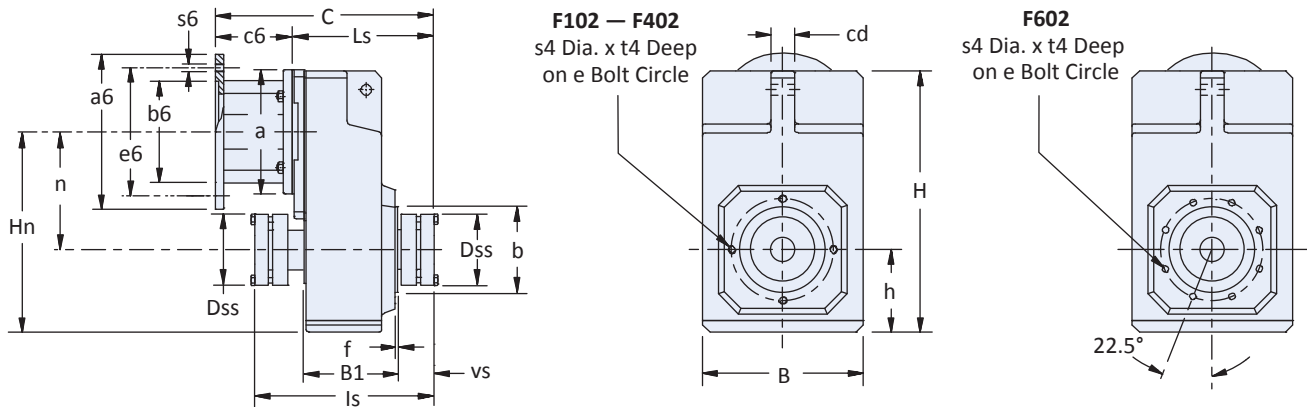

Table 1 F Series Unit Dimensions (Inches) — “W” Double Side Wobble Free Bushing

Base Module	B	b	B1	cd	Dss	e	f
F102	5.71	2.953	3.43	0.79	2.68	3.54	0.10
F202	7.09	3.740	4.13	0.87	3.07	4.53	0.12
F302	8.11	4.331	4.72	1.18	3.31	5.12	0.14
F402	9.06	4.331	5.31	1.18	3.82	5.12	0.14
F602	10.43	5.118	6.54	1.38	4.13	6.50	0.14

Table 2 F Series Unit Dimensions (Inches) — “W” Double Side Wobble Free Bushing

Base Module	H	h	Hn	ls	n	s4	t4	vs
F102	9.37	2.91	6.93	6.73	4.02	M8x1.25	0.51	1.18
F202	11.77	3.66	8.82	7.77	5.16	M8x1.25	0.51	1.54
F302	13.23	4.17	10.06	8.46	5.89	M10x1.5	0.63	1.54
F402	14.57	4.57	11.22	9.57	6.65	M10x1.5	0.63	1.78
F602	17.64	5.39	13.11	10.84	7.72	M10x1.5	0.63	1.77

Table 3 Bushing Capscrew Dimensions

Base Module	Bushings Capscrew Qty – Size x Length (mm)	Tightening Torque	
		in. lbs	Nm
F102	6 – M6 x 1 x 25	89	10
F202	8 – M6 x 1 x 30	89	10
F302	8 – M6 x 1 x 30	89	10
F402	8 – M8 x 1.25 x 30	221	25
F602	8 – M8 x 1.25 x 30	221	25

Table 4 Required Output Shaft Length*

Base Module	Length (in)
F102	7.04
F202	8.18
F302	8.89
F402	10.03
F602	11.30

* **Important:** A 1/32" x 45° chamfer minimum is recommended for the shaft end. The bushing will accept a shaft with a tolerance of +0.000/-0.005 in.



Dimensional Data

Table 5 F Series Unit Dimensions (inches) — “MR” Motor Adapter

Motor Adapter	NEMA C-Flange	a	a6	b6	c6	e6	s6	Wt. lbs
MR140/050	56C	5.51	6.50	4.500	3.31	5.87	0.41	9
MR160/050	56C	6.30	6.50	4.500	3.86	5.87	0.41	16
MR160/140	143/145TC							
MR200/180	182/184TC	7.87	9.00	8.500	4.80	7.25	0.55	23
MR250/180	182/184TC	9.84	9.00	8.500	5.31	7.25	0.55	36
MR250/210	213/215TC							

Table 6 Motor Adapter Dimensions (Inches)

Base Module	MR140/050		MR160/050 MR160/140		MR200/180		MR250/180 MR250/210		Wt. lbs*
	C	Ls	C	Ls	C	Ls	C	Ls	
F102	8.42	5.11	—	—	—	—	—	—	38
F202	9.50	6.19	10.21	6.35	—	—	—	—	51
F302	10.09	6.78	10.80	6.94	11.82	7.02	—	—	67
F402	—	—	11.63	7.77	12.65	7.85	—	—	84
F602	—	—	12.84	8.98	13.86	9.06	14.49	9.18	165

* Weight is base unit only. MR weight must be added separately.

Table 7 “WFN” Double Side Bushings Stock Bore Sizes — Stainless Steel

NOTE: Single side bushing kits include 1 each of the pressure and locking ring, tapered cone, support ring, and all hardware to mount the kit into the MGS reducer. The WF1 bushing does not use a tapered cone. The bushing will accept a shaft with a tolerance of +0.000/-0.005.

Base Module	Imperial — Inches													Metric — mm			
	3/4	1	1-3/16	1-1/4	1-3/8	1-7/16	1-1/2	1-5/8	1-11/16	1-3/4	1-7/8	1-15/16	2	20	30	35	40
F102	WFN1-075	—	—	—	—	—	—	—	—	—	—	—	—	WFN1-20	—	—	—
F202	—	WFNK2-100	WFNK2-103	—	—	—	—	—	—	—	—	—	—	—	—	—	—
F302	—	WFN3-100	WFN3-103	WFN3-104	WFN3-106	WFN3-107	WFN3-108	—	—	—	—	—	—	—	WFN3-30	WFN3-35	—
F402	—	WFN4-100	WFN4-103	WFN4-104	WFN4-106	WFN4-107	WFN4-108	—	—	—	—	—	—	—	—	—	WFN4-40
F602	—	—	—	—	—	WFN5-107	WFN5-108	WFN5-110	WFN5-111	WFN5-112	WFN5-114	WFN5-115	WFN5-200	—	—	—	WFN5-40

F Series: OFFSET — Solid Shaft / Hollow Output

Technical Reference

Output Options

BLUE: standard output diameters in stock
BLACK: optional diameters in stock
 Other options are available upon request. Please contact STÖBER to learn about other options and their deliveries.

Important: Refer to specific product dimension drawings for hollow bore and wobble free bushing required shaft length specifications.

KSS Series (Stainless Steel)

		KSS1	KSS2	KSS3	KSS4
Solid Shaft	Inches	1	1-1/4	1-1/4	1-3/8
Hollow Bore	Inches	1	1-1/4	1-3/8	1-1/2
	Req. Shaft Length	3.86	4.78	4.92	6.18
Wobble Free Bushing	Inches	1	1 1-3/16 1-1/4 1-3/8 1-7/16 1-1/2	1 1-3/16 1-1/4 1-3/8 1-7/16 1-1/2	1-3/16 1-1/4 1-3/8 1-7/16 1-1/2
	Metric	25	30 35	30 35	40
Req. Shaft Length	wCovers	7.85	9.28	9.75	11.38
	w/oCovers	7.49	9.00	9.47	11.04

KL Series

			KL2
Solid Shaft	Carbon Steel	Inches	3/4
		Metric	20
	Stainless Steel	Inches	3/4
		Metric	20 22
Hollow Bore	Carbon Steel	Inches	3/4
		Metric	20
	Stainless Steel	Inches	3/4
		Req. Shaft Length	
Wobble Free Double Bushing	Stainless Steel	Inches	3/4
		Req. Shaft Length	
	w/oCovers		6.97

K Series

			K1	K2	K3	K4	K5	K6	K7	K8	K9	K10	
Solid Shaft	Carbon Steel	Inches	1	1-1/4	1-1/4	1-3/8	1-3/4	1-3/4	2-3/8	2-7/8	3-5/8	4-3/8	
		Metric	25	30	30	40	45	50	60	70	90	110	
	Stainless Steel	Inches	1	1-1/4	1-1/4	1-3/8	1-3/4	1-3/4	2-3/8	2-7/8	3-5/8	—	
		Metric	25	30	—	—	45	—	—	—	—	—	
Hollow Bore	Carbon Steel	Inches	1	1-3/16	1-3/8	1-1/2	2	2	2-3/8	2-3/4	3-1/4	4	
		Metric	25	30	35	40	50	50	60	70	90	—	
	Stainless Steel	Inches	1	1-1/4	1-3/8	1-1/2	2	2	2-3/8	—	2-15/16 3 3-7/16	—	
		Metric	25	30	35	40	50	—	60	—	—	—	
Req. Shaft Length			3.86	4.78	4.92	6.18	6.46	7.05	8.43	10.35	11.89	14.25	
Wobble Free Bushing <small>(Stainless Steel except where noted)</small>	Inches	Single & Double	1	1 1-3/16 1-1/4	1* 1-3/16* 1-1/4* 1-3/8* 1-7/16* 1-1/2*	1 1-3/16 1-1/4 1-3/8 1-7/16 1-1/2	1-7/16 1-1/2 1-5/8 1-11/16 1-3/4 1-7/8 1-15/16 2	1-7/16 1-1/2 1-5/8 1-11/16 1-3/4 1-15/16 2 2-3/16	1-15/16 2 2-3/16 2-3/8	2-3/16 2-3/8 2-7/16 2-3/4	—	—	
		Metric	Single	25	30	30 35	—	—	—	—	—	—	—
	Req. Shaft Length	wCovers	All	7.97	9.23	9.76	11.42	11.89	12.99	14.83	17.60	—	—
		w/oCovers	Single	7.06	8.32	8.81	10.26	10.80	11.81	13.41	16.20	—	—
		Double	7.73	8.99	9.50	11.11	11.61	12.75	14.33	17.29	—	—	

*Also available in carbon steel

C Series

			C0	C1	C2	C3	C4	C5	C6	C7	C8	C9
Solid Shaft	Carbon Steel	Inches	3/4	1	1-1/4	1-1/4	1-5/8	1-5/8	2-1/8	2-3/8	2-7/8	3-5/8
		Metric	20	25	30	30	40	40	50	60	70	90
	Stainless Steel	Inches	3/4	1	1-1/4	1-1/4	1-5/8	1-5/8	2-1/8	2-3/8	2-7/8	—
		Metric	—	—	—	25	—	—	—	—	—	—

F Series

			F1	F2	F3	F4	F6
Solid Shaft	Carbon Steel	Inches	1	1-1/4	1-3/8	1-5/8	2-1/8
		Metric	—	—	—	—	—
	Stainless Steel	Inches	—	—	—	—	—
		Metric	—	—	—	—	—

Hollow Bore	Carbon Steel	Inches	3/4	1	1-1/4	1-7/16 1-1/2	2
		Metric	20	25	30	40	50
	Stainless Steel	Inches	—	—	1-1/4	1-1/2	—
		Metric	—	—	—	—	—
Req. Shaft Length			2.87	3.62	4.06	4.49	5.63

Wobble Free Bushing (Single & Double Bushings*)	Stainless Steel	Inches	3/4	1 1-3/16	1 1-3/16 1-1/4 1-7/16 1-1/2	1-7/16 1-1/2	1-7/16 1-1/2 1-15/16 2
			Metric	20	—	—	40**
		Req. Shaft Length		Single	6.57	7.51	8.20
		Double	7.04	8.18	8.89	10.03	11.30

* Double bushings only available with two stage units ** Double bushing only

Standard & Optional Output Flange Sizes

K Series

Base Module	Flange Size		
K1	140	160*	
K2	160	200*	
K3	160	200*	250
K4	250*		
K5	250*		
K6	300*		
K7	300	350*	
K8	350	400*	450
K9	450*		
K10	550*		

C Series

Base Module	Flange Size		
C0	120	140	160*
C1	140	160	200*
C2	160	200*	250
C3	160	200	250*
C4	200	250*	300
C5	250	300*	
C6	300*		
C7	350*		
C8	350	400*	450
C9	450*		

* This is the standard flange size and will be shipped unless otherwise specified. Optional flanges are not available for all sizes.

Technical Reference

STOBER Motor Hub Mounting Gage

For ease of motor coupling hub location and installation, the STOBER motor hub mounting gage is designed to fit most sizes of “MR” style motor adapters (used with C, F and K units), as well as The “MS” style adapters with the KSS series.

This simple-to-use gage makes it easy to position the motor coupling hub on the shaft quickly and accurately, insuring maximum motor/speed reducer performance and life.

A paper motor hub mounting gage is included with each MGS speed reducer order. Stainless steel motor hub mounting gages are also available. Contact STOBER to order, using the appropriate part number listed below.

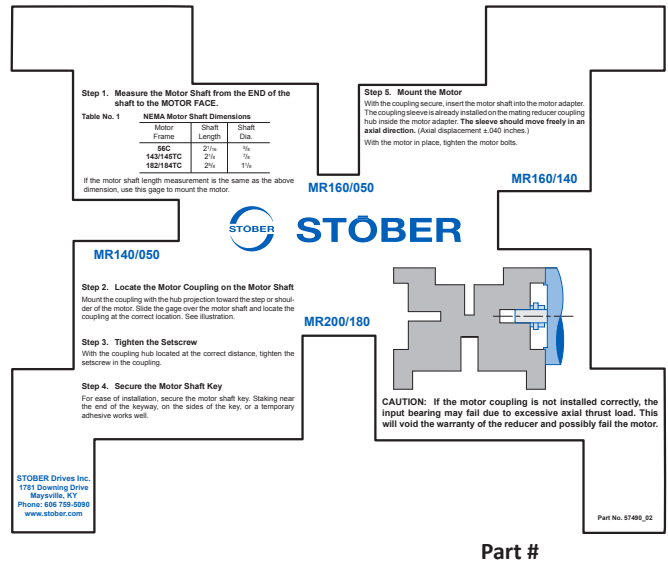

Gages for C, F, K Series

	Paper	Stainless Steel
Gages for use with MR140/050, MR160/050, MR160/140 and MR200/180 adapters	57490	5000070
Gage for use with MR 250/210 and MR300/250 adapters	213000	5000069
Gages for KSS Series		
Gages for use with KSS Series all MS style adapters	5000085	5000084

Tolerances

Motor Adapter (KSS, KL, K, C, F)

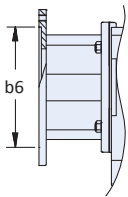

Bore (in)	Pilot Bore Diameter b6
1.96 — 3.15	+0.0007/-0.0005
3.15 — 4.72	+0.0008/-0.0006
4.72 — 7.09	+0.0010/-0.0007
7.09 — 9.84	+0.0012/-0.0008
9.84 — 12.40	+0.0014/-0.0009

Output – Flange Mount (KSS, KL, K, C, F)

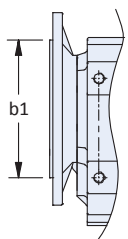

Diameter (in)	Pilot Diameter b1
>1.96 — 3.15	+0.0005/-0.0003
>3.15 — 4.72	+0.0005/-0.0004
>4.72 — 7.09	+0.0006/-0.0004
>7.09 — 9.84	+0.0006/-0.0005
>9.84 — 12.40	+0.0006/-0.0006
>12.40 — 15.74	+0.0007/-0.0007

Output – Solid Shaft (KSS, KL, K, C, F)

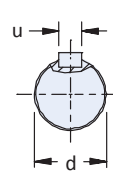

Diameter (in)	d	u
0.39 — 0.71	+0.0000/-0.0005	+0.0019/ -0.0000
0.71 — 1.18	+0.0000/-0.0006	
1.18 — 1.97	+0.0000/-0.0007	
1.97 — 3.15	+0.0000/-0.0008	
3.15 — Up	+0.0000/-0.0009	

Output – Hollow Bore (KSS, KL, K, C, F)

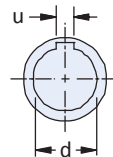

Bore (in)	d	u
0.39 — 0.71	+0.0007/-0.0000	+0.0019/ -0.0000
0.71 — 1.18	+0.0008/-0.0000	
1.18 — 1.97	+0.0010/-0.0000	
1.97 — 3.15	+0.0012/-0.0000	
3.15 — Up	+0.0014/-0.0000	

Motor Adapter Coupling Hub and Sleeve

Motor coupling hub and sleeves are provided with the motor adapter. These parts, with a coupling shaft component that is part of the reducer, make a complete coupling to connect the motor to the reducer.

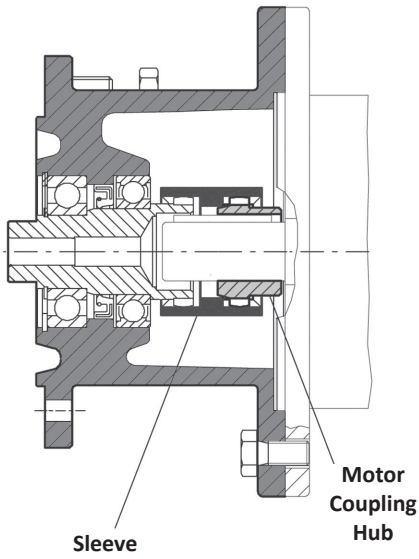

“MR” Motor Adapters (K, C, F)

Adapter	NEMA Frame	Motor Hub	Sleeve
MR140/050	56C	M-19 x 5/8	M-19
MR160/050	56C	M-24 x 5/8	M-24
MR160/140	143/145TC	M-24 x 7/8	M-24
MR200/050	56C	M-32 x 5/8	M-32
MR200/140	143/145TC	M-32 x 7/8	M-32
MR200/180	182/184TC	M-32 x 1-1/8	M-32
MR250/180	182/184TC	M-38 x 1-1/8	M-38
MR250/210	213/215TC	M-38 x 1-3/8	M-38
MR300/180	182/184TC	M-48 x 1-1/8	M-48
MR300/210	213/215TC	M-48 x 1-3/8	M-48
MR300/250	254/256TC	M-48 x 1-5/8	M-48
MR300/280	284/286TC	M-48 x 1-7/8	M-48
MR350/320	324/326TC	M-65 x 2-1/8	M-65
MR350/360	364/365TC	M-65 x 2-3/8	M-65

“MS_R” Motor Adapters (KSS)

Adapter	NEMA Frame	Motor Hub	Sleeve
MS1R050	56C	M-19 x 5/8	M-19
MS2R050	56C	M-24 x 5/8	M-24
MS2R140	143/145TC	M-24 x 7/8	M-24
MS3R050	56C	M-24 x 5/8	M-24
MS3R140	143/145TC	M-24 x 7/8	M-24
MS3R180	182/184TC	M-32 x 1-1/8	M-32
MS4R050	56C	M-24 x 5/8	M-24
MS4R140	143/145TC	M-24 x 7/8	M-24
MS4R180	182/184TC	M-32 x 1-1/8	M-32
MS5R050	56C	M-32 x 5/8	M-32
MS5R140	143/145TC	M-32 x 7/8	M-32
MS5R180	182/184TC	M-32 x 1-1/8	M-32
MS7R180	182/184TC	M-32 x 1-1/8	M-32

“ML” Motor Adapters (KL)

Adapter	NEMA Frame	Motor Hub	Sleeve
ML2R050	56C	M-19 x 5/8	M-19

Thermal Ratings

HP	kW	Series - Size				
		KSS	KL	K	C	F
2.95	2.2	1		1	0	1
2.00	2.2					
3.02	2.3		2			
5.36	4.0	2		2	1	2
6.00	4.5					
7.38	5.5	3		3	2	3
11.25	8.4					
12.34	9.2	4		4	3	4
14.75	11.0			5	4	5
20.12	15.0			6	5	6
29.50	22.0			7	6	
40.23	30.0			8	7	
53.64	40.0			9	8	
67.05	50.0			10	9	

Technical Reference

Conversions

Imperial to Metric	Metric to Imperial
1 inch x 25.4 = mm	mm x 0.03937 = inch
1 in ² x 645.16 = mm ²	1 mm ² x 0.0015 = in ²
1 lb x 0.453 = kg	1 kg x 2.205 = lb
1 US gal x 3.785 = L	1 L x 0.264 = US gal
1 HP x 0.746 = kW	1 kW x 1.341 = HP
1 lb x 4.45 = N	1 N x 0.225 = lb
1 lb in x 0.113 = Nm	1 Nm x 8.85 = lb in
1 lb ft x 1.36 = Nm	1 Nm x 0.737 = lb ft
1 lb ft x .1383 = kgm	1 kgm x 7.233 = lb ft
1 lb in x .0115 = kgm	1 kgm x 86.798 = lb ft
1 lb in ² x 0.00029 = kgm ²	1 kgm ² (J) x 3418.0 = lb in ² (WR ²)
1 PSI x 0.0689 = bar	1 bar x 14.5 = PSI
1 PSI x 0.00689 = N/mm ²	1 N/mm ² x 145.04 = PSI
°F = 32 + 9/5 x °C	°C = 5/9 (°F-32)

Calculating HP

Use this equation to calculate the HP required for an application:

$$HP = \frac{1.732 \times \text{Volts} \times \text{Amps} \times \text{Eff} \times \text{PF}}{746}$$

Where: **Volts** = Motor Running Volts (i.e. 230V or 460V)

Amps = Measured Full Load Amps

Eff = Motor Efficiency

PF = Motor Power Factor

Formulas

1 HP =	36 in.lbs @ 1750 RPM
1 HP =	54 in.lbs @ 1160 RPM
HP =	Force x FPM / 33,000
HP =	T (in.lbs) x RPM / 63,025
HP =	T (ft.lbs) x RPM / 5,252
T (in.lbs) =	63,025 x HP / RPM
T (ft.lbs) =	5,252 x HP / RPM
Feet/Minute =	0.2618 x Dia. (in) x RPM
Meters/Minute =	0.00314 x Dia. (mm) x RPM
RPM =	Feet/Minute / 0.2618 x Dia. (in)
RPM =	63,025 x HP / Torque
T =	Force x Lever Arm
F =	Torque / Radius

Return Delivery Note

Service Notification: 400003901

Terms relating to returns of unit for refurbishment are as follows:

1. Products sent to STÖBER for evaluation, repair and/or maintenance ("Returned Products") will be held for 30 business days. If, after STÖBER contacts, or attempts to contact, the Customer regarding such product, the Customer does not respond within 25 days, STÖBER will consider the Customer's product to be abandoned and may dispose of such product at its discretion. STÖBER may retain any residual scrap value for the disposal of the Customer's product. The shipment to STÖBER of any Returned Products constitutes acceptance of all terms contained herein.
2. All returned products must be returned freight prepaid to Maysville, Ky. and are subject to inspection prior to issue of credit.
3. For a level 1 evaluation the Non-warranty inspection fee is \$100.00. This fee is not charged if repair and/or a replacement is purchased. A purchase order is required. A level 1 evaluation will include Visual inspection, evaluate unit for failure mode as described by customer. Failure explanation via e-mail with pictures as needed.
4. For a level 2 evaluation the Non-warranty inspection fee is \$500. Oil Sample Inspection, Bearing Inspection, Seal Inspection, Gearing Inspection and Root Cause Analysis performed by SDI. Failure Report in PDF format with Pictures.
5. For a level 3 evaluation the Non-warranty inspection fee is \$1000 + all outside lab fees and shipping cost. A purchase order is required. Oil Sample saved, Bearing Inspection performed by original manufacture, Seal Inspection performed by original manufacture. Gearing Inspection and Root Cause Analysis performed by SDI. Failure Report in PDF format with Pictures.
6. Units returned freight collect or without an RGA number clearly marked on outside of shipping package will NOT be accepted.
7. If RGA is for product damaged during shipment to you, please contact carrier who caused damage for inspection. Upon completion of inspection, have DAMAGING carrier return goods to STÖBER Drives Inc.
8. Receipt of this unit will be REFUSED, if not in a secure, well-supported package so that they are not damaged in shipment to us.
9. Warranty on original unit remains in place after repair. No new warranty is issued for repaired units.

Terms and Conditions of Sale

- 1. GENERAL.** All orders for products supplied by STOBBER DRIVES INC. ("STOBBER") shall be subject to these terms and conditions of sales. All transactions shall be governed by the laws of the Commonwealth of Kentucky. No modifications hereto will be binding unless agreed to in writing by STOBBER.
- 2. CUSTOMER.** The term "Customer," as used herein, means the distributor, resale dealer, original equipment manufacturer or first end-user customer that purchases the STOBBER products.
- 3. WARRANTY.** STOBBER products shall be free from defects in material and workmanship for a maximum of 5-years (single shift operation or 30 months multiple shift operation) for ServoFit products (ServoFit Modular System, ServoFit Precision Planetary Gearheads, and ServoFit Geared Motors) and MGS Long Life products; 3-years (single shift operation or 18 months multiple shift operation) for other MGS products; 2-years (single shift operation or 12 months multiple shift operation) for ComTrac products, from the date of shipment to the Customer. For ServoFit products, the motor on ServoFit Geared Motors, as well as all normal wear items, including oil seals and bearings, shall be covered for a period of 2-years (single shift operation or 12 months multiple shift operation). In the event that a product proves to be defective, STOBBER's sole obligation shall be, at its option, to repair or replace the product. The repaired or replacement product will be shipped F.O.B. STOBBER's facilities, freight prepaid by STOBBER.

No employee, agent or representative of STOBBER has the authority to waive, alter, vary or add to the terms hereof without the prior written approval of an officer of STOBBER. It is expressly agreed that (a) this section constitutes the final expression of the parties' understanding with respect to the warranty and (b) this section is a complete and exclusive statement of the terms of the warranty.

STOBBER shall have no obligation under the warranty set forth above in the event that:

- (a) The Customer fails, within the warranty period to notify STOBBER in writing and provide STOBBER with evidence satisfactory to STOBBER of the alleged defect within five (5) days after it becomes known to the customer;
- (b) After inspection of a product, STOBBER determines, in its sole discretion, that it is not defective in material or workmanship;
- (c) Repair or replacement of a product is required through normal wear and tear;
- (d) Any part in a product or any ingredient contained in a product requires replacement or repair through routine usage or normal wear and tear;
- (e) A product is not maintained or used in accordance with STOBBER's applicable operating and/or maintenance manuals, whether by the Customer or any third party;
- (f) A product has been subject to misuse, misapplication, negligence, neglect (including, but not limited to, improper maintenance or storage), accident, catastrophe, improper installation, modification, adjustment, repair or lubrication, whether by the Customer or any third party, without the prior written consent of STOBBER. Misuse shall include, but not be limited to, deterioration in a product due to chemical action and wear caused by the presence of abrasive materials;
- (g) The system of connected rotating parts into which the product becomes incorporated is not compatible with the product, or it is not free from critical speed or torsional or other type of vibration within the specified operating range, no matter how induced; or
- (h) The transmitted load and imposed torsional thrust and overhung loads are not within the published capacity limits for the unit sold.

Items manufactured by other parties but installed in or affixed to STOBBER's products are not warranted by STOBBER and bear only those warranties, express or implied, which are given by the manufacturer of such items, if any.

THE WARRANTY SET FORTH ABOVE IS INTENDED SOLELY FOR THE BENEFIT OF THE Customer AND DOES NOT APPLY TO ANY THIRD PARTY. ALL CLAIMS MUST BE MADE BY THE CUSTOMER AND MAY NOT BE MADE BY ANY THIRD PARTY. THIS WARRANTY MAY NOT BE TRANSFERRED OR ASSIGNED, IN WHOLE OR IN PART, BY THE CUSTOMER FOR ANY REASON WHATSOEVER. ANY SUCH ATTEMPTED TRANSFER OR ASSIGNMENT SHALL BE NULL AND VOID.

THIS WARRANTY TAKES THE PLACE OF ALL OTHER WARRANTIES, EXPRESS OR IMPLIED, WHICH ARE HEREBY DISCLAIMED AND EXCLUDED BY STOBBER, INCLUDING WITHOUT LIMITATION, ANY WARRANTY OF MERCHANTABILITY OR FITNESS FOR A PARTICULAR PURPOSE OF USE AND ALL OBLIGATIONS OR LIABILITIES ON THE PART OF STOBBER FOR DAMAGES ARISING OUT OF OR IN CONNECTION WITH THE USE, REPAIR OR PERFORMANCE OF THE PRODUCTS.

4. MODIFICATIONS. STOBBER reserves the right, without notice to the Customer, to (a) change the specifications of any product, (b) improve a product in any manner that STOBBER deems necessary or appropriate and (c) discontinue the manufacture of any product.

5. PURCHASE ORDERS. The Customer will submit purchase orders for the products to STOBBER in writing, whether by mail or telefax, which shall set forth, at a minimum: (a) an identification of the products ordered, (b) prices for such products, (c) quantities, (d) requested delivery dates and (e) shipping instructions and shipping addresses.

6. ACCEPTANCE OF ORDERS. All purchase orders received from the Customer are subject to acceptance by STOBBER in writing.

7. MODIFICATION OF ORDERS. No accepted purchase order shall be modified or canceled except upon the written agreement of STOBBER and the Customer. Mutually agreed cancellations shall be subject to reasonable charges based upon expenses already incurred by STOBBER and commitments made by STOBBER. Mutually agreed change orders shall be subject to all provisions of these Terms and Conditions of Sale.

8. PRICE INCREASES. STOBBER may increase its prices for the products by providing the original purchaser of the products with at least thirty (30) days' prior written notice. Increased prices for products shall not apply to purchase orders accepted prior to the effective date of the price increase unless such orders provide for delivery more than thirty (30) days after the date of acceptance of the order.

9. PRICING AND DELIVERY TERMS. In accordance with KRS 355.2-319(1)(b), all products are delivered F.O.B. STOBBER's warehouse facility in Maysville, Kentucky, or such other facility as STOBBER may designate. Orders are then shipped per Customer's shipping instructions as set forth in Customer's purchase order. **CATALOG PRICING DOES NOT INCLUDE SHIPPING, HANDLING AND TAXES.** Once delivered to a common carrier of the Customer's choosing [or of STOBBER's choosing if Customer has failed to specify a common carrier on or before five (5) days prior to the requested delivery date] STOBBER shall have no further responsibility for the products and all risk of damage, loss or delay shall pass to the Customer. A handling fee is added to freight costs by STOBBER to cover the cost of having to pay the carrier within seven (7) days when the terms with the Customer are net 30. The Customer has the option of shipping collect with our carrier or the carrier of choice.

10. PAYMENT TERMS. Net 30 days. All orders will be shipped either prepaid by the Customer or C.O.D., at STOBBER's option, unless the Customer has established a previously approved credit line. If STOBBER approves a credit line for the Customer, all payments shall be due within thirty (30) days of the date of the invoice. If any invoice is not paid in full within such thirty (30) day period, then finance charges shall be assessed at the rate of one and one-half percent (1½%) per month (eighteen percent (18%) per year). If such rate is deemed to be usurious at any time, it shall be reduced to the maximum rate permitted by applicable

law. STOBBER may stop or withhold shipment of products if the Customer does not fulfill its payment obligations. If STOBBER is insecure about payment for any reason, STOBBER may require full or partial payment in advance and as a condition to the continuation of its delivery of products.

11. SECURITY INTEREST. Unless and until the products are paid for in full, STOBBER reserves a security interest in them to secure the unpaid balance of the purchase price. The Customer hereby grants to STOBBER a power of attorney, coupled with an interest, to execute and file on behalf of the Customer all necessary financing statements and other documents required or appropriate to protect the security interest granted herein.

12. ACCEPTANCE OF PRODUCTS. The Customer will conduct any incoming inspection tests as soon as possible upon arrival of the products, but in no event later than ten (10) days after the date of receipt. Any products not rejected by written notice to STOBBER within such period shall be deemed accepted by the Customer. STOBBER shall not be liable for any additional costs, expenses or damages incurred by the Customer, directly or indirectly, as a result of any shortage, damage or discrepancy in a shipment.

13. LIMITATION OF REMEDIES.

(a) STOBBER SHALL NOT BE LIABLE FOR ANY LOSS OR DAMAGE CAUSED BY DELAY IN FURNISHING THE CUSTOMER WITH PRODUCTS.

(b) IN NO EVENT SHALL STOBBER'S LIABILITY INCLUDE ANY SPECIAL, INDIRECT, INCIDENTAL OR CONSEQUENTIAL LOSSES OR DAMAGES, EVEN IF STOBBER HAS BEEN ADVISED OF THE POSSIBILITY OF SUCH POTENTIAL LOSS OR DAMAGE.

14. MADE-TO-ORDER PRODUCTS. STOBBER reserves the right to revoke and amend any price quotations offered to the Customer for made-to-order products, provided that such price quotations have not been accepted by the Customer prior to the date of revocation or amendment.

15. DIES, TOOLS AND EQUIPMENT. Charges incurred by the Customer for dies, tools and other equipment shall not confer ownership or the right to possession therein by the Customer. All such dies, tools and equipment shall remain the property of STOBBER, and STOBBER shall have the exclusive right to possession thereof. STOBBER shall maintain such tools and equipment in good working order.

16. REGULATORY LAWS AND STANDARDS. STOBBER makes no representation that its products conform to state or local laws, ordinances, regulations, codes or standards except as may be otherwise agreed to in writing by STOBBER.

17. SIZES AND WEIGHTS. STOBBER's products are made only in the sizes and to the specifications set forth in its catalogs and other literature. If any alteration is requested, such altered product will be treated as a made-to-order item. STOBBER assumes no responsibility for typographical errors which may appear in its catalogs or literature, and cannot accept alteration charges caused by such errors. Since weights shown in STOBBER's catalogs are approximate, they cannot be used in determining freight allowances set forth in its catalogs and other literature. Freight allowances will be determined at the time of shipment and shall be based on actual shipping weight.

18. SYSTEM DESIGN. Responsibility for system design to ensure proper use and application of STOBBER's products within their published specifications and ratings rests solely with the Customer. This includes, but is not limited to, an analysis of loads created by torsional vibrations within the entire system, regardless of how induced.

STOBBER DRIVES INC.

1781 Downing Drive • Maysville, KY 41056
Phone: (606) 759-5090 • FAX: (606) 759-5045
www.stober.com • E-mail: sales@stober.com

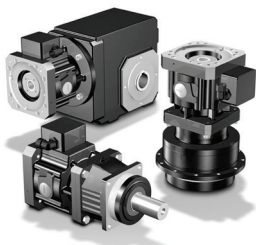

ServoStop

Motor Adapter with Integrated Brake

Motor adapter integrated brake module provides redundant braking during power failures or emergency stops in hazardous situations. Available with Servo P, PA, PH, PHA, PK, PHK, C, F and K Series Gearheads.

- Saves braking at EMERGENCY STOP and power cut
- Prevents accidental sliding or falling of vertical axis with gravity load absolutely reliable
- Manual hand release available
- Fits all standard servo motors
- IP54 Rated; CSA Approved
- Higher safety for vertical applications per EN ISO 13849, Category 1, 2 & 3



Servo Gear Boxes

- Inline concentric, offset or right angle
- Helical, bevel or worm gear driven
- Input RPM up to 8,000
- Output torques to +200,000 lb-in
- Ratios from 3:1 to 600:1
- Backlash as low as <1 arc minute
- Food and corrosion resistant duty stainless steel available

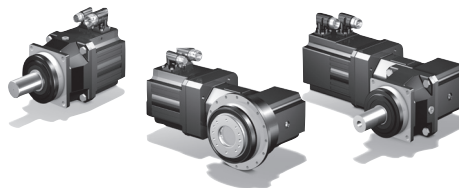

Servo Geared Motors

ED and EZ Series are compact, highly-dynamic, electronically commutated, permanent magnet brushless servo motors coupled to STÖBER gearheads.

- Mounting the motor directly to the gearbox eliminates a motor coupling and housing, adapter or additional input seals and bearings to reduce inertia up to 75%
- Smoother running for optimal performance; dynamic, minimal torque/speed ripple; UL/CE/CSA approved
- Options include: washdown, food coatings, spring and magnetic brakes, forced air cooling, water cooling, high dynamic performance with low inertia, encoder options, PTC or KTY winding protection, high inertia option, motor speeds up to 6000 RPM, and high torque density

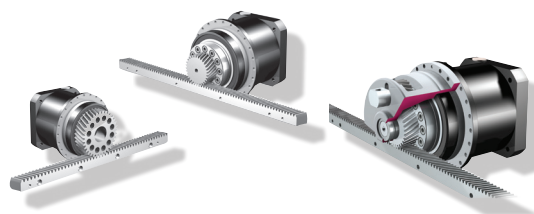

Rack and Pinion Systems

STÖBER and Atlanta partner on ZV, ZR, ZTR, ZTRS Series high efficiency rack and pinion drives which feature an innovative pinion bearing for high linear force applications.

- Gear unit and rack optimally mated together as a system
- Ready to install drive solutions
- Easy selection and calculations done by STÖBER for a total engineered solution
- Optimize inertia mismatch by changing the gear ratio or pinion tooth count
- Forces up to 122 kN or 27,400 lbs.
- Precision linear backlash as low as 7 μ m
- Gearing size ranges from Mod. 2 – 10

STOBER
1781 Downing Drive
Maysville, KY 41056
(800) 711-3588
Fax (606) 759-5045
e-mail: sales@stober.com
www.stober.com

MGS Version 31 Form #442933 10/24



STOBER

MGS[®] Speed Reducers

V.31